

EXPANSION SITE PLAN

31 May 2019

Car Pros Kia
Moreno Valley, California

LOT AREA (GROSS):	269,708 sf (6.19 acres)
LOT AREA (NET):	267,510 sf (6.14 acres)
PARCEL 7:	117,180 sf (2.69 acres)
PARCEL 8:	150,330 sf (3.45 acres)
BUILDING AREA:	41,511 sf
FIRST FLOOR:	32,727 sf
SECOND FLOOR:	10,490 sf
CAR WASH:	856 sf
SERVICE RECEPTION:	2,562 sf
COVERAGE (ON NET):	12.55%
PARCEL 7:	0%
PARCEL 8:	22.34%
FLOOR AREA RATIO (ON NET):	16.48%
PARCEL 7:	0%
PARCEL 8:	29.32%
PARKING REQUIRED:	23 spaces
44,073 s.f. at 1 / 2,000 s.f.	
PARKING PROVIDED	56 spaces
STANDARD:	52 spaces
HANDICAP ACCESSIBLE:	4 spaces
LANDSCAPE PROVIDED:	58,846 sf (22.00%)
PARCEL 7:	30,108 sf (25.69 %)
PARCEL 8:	28,738 sf (19.12%)

p:\2018\18053 car pros kia - moreno valley, ca\cad\01_sdl\planning package\18053 site plan.dwg
30 May 2019

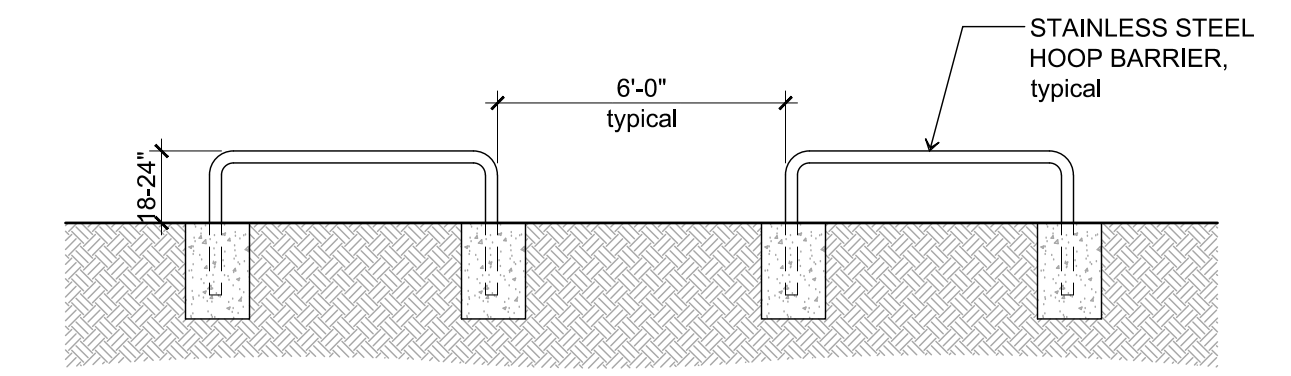

STEEL HOOP BARRIER

SCALE: 1/4" = 1'-0"

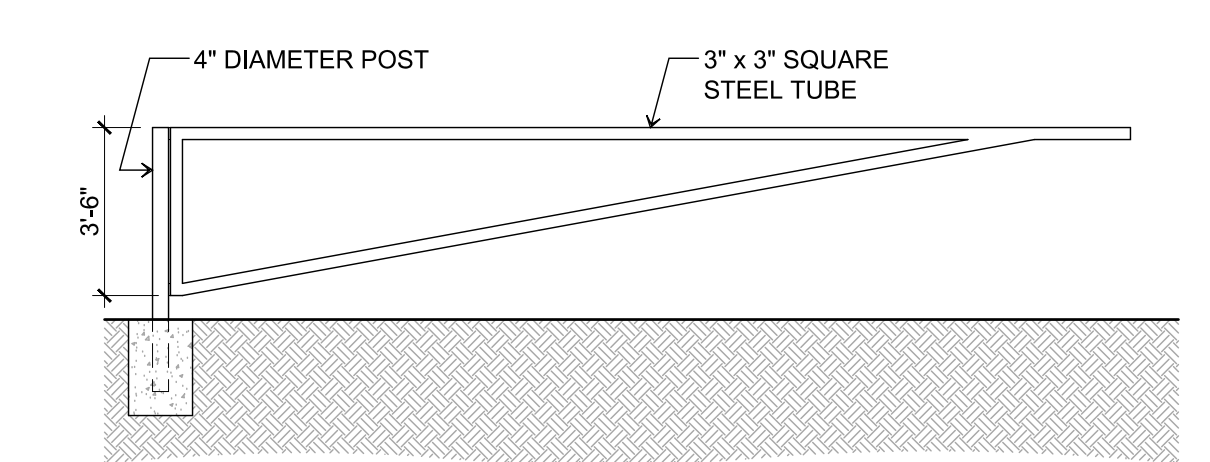

SWING BARRIER GATE

SCALE: 1/4" = 1'-0"

