

AGENDA
CITY COUNCIL OF THE CITY OF MORENO VALLEY
MORENO VALLEY COMMUNITY SERVICES DISTRICT
CITY AS SUCCESSOR AGENCY FOR THE
COMMUNITY REDEVELOPMENT AGENCY OF
THE CITY OF MORENO VALLEY
MORENO VALLEY HOUSING AUTHORITY
BOARD OF LIBRARY TRUSTEES
February 26, 2013

REGULAR MEETING – 6:00 P.M.

City Council Study Sessions

First & Third Tuesday of each month – 6:00 p.m.

City Council Meetings

Second & Fourth Tuesdays of each month – 6:00 p.m.

City Council Closed Session

First & Third Tuesday of each month – 6:00 p.m.

*Immediately following Regular City Council Meetings
and Study Sessions, unless no Closed Session Items are scheduled*

City Hall Council Chamber - 14177 Frederick Street

Upon request, this agenda will be made available in appropriate alternative formats to persons with disabilities, in compliance with the Americans with Disabilities Act of 1990. Any person with a disability who requires a modification or accommodation in order to participate in a meeting should direct such request to Mel Alonzo, ADA Coordinator, at 951.413.3705 at least 48 hours before the meeting. The 48-hour notification will enable the City to make reasonable arrangements to ensure accessibility to this meeting.

Marcelo Co, Mayor Pro Tem
Jesse L. Molina, Council Member

Tom Owings, Mayor

Richard A. Stewart, Council Member
Victoria Baca, Council Member

**AGENDA
JOINT MEETING OF THE
CITY COUNCIL OF THE CITY OF MORENO VALLEY
MORENO VALLEY COMMUNITY SERVICES DISTRICT
CITY AS SUCCESSOR AGENCY FOR THE
COMMUNITY REDEVELOPMENT AGENCY OF THE
CITY OF MORENO VALLEY
MORENO VALLEY HOUSING AUTHORITY
AND THE BOARD OF LIBRARY TRUSTEES**

***THE CITY COUNCIL RECEIVES A SEPARATE STIPEND FOR CSD
MEETINGS***

**REGULAR MEETING - 6:00 PM
FEBRUARY 26, 2013**

CALL TO ORDER

(Joint Meeting of the City Council, Community Services District, City as Successor Agency for the Community Redevelopment Agency, Housing Authority and the Board of Library Trustees - actions taken at the Joint Meeting are those of the Agency indicated on each Agenda item)

PLEDGE OF ALLEGIANCE

INVOCATION - Pastor Mark Orellana - Victory Outreach

ROLL CALL

INTRODUCTIONS

PUBLIC COMMENTS ON MATTERS ON THE AGENDA WILL BE TAKEN UP AS THE ITEM IS CALLED FOR BUSINESS, BETWEEN STAFF'S REPORT AND CITY COUNCIL DELIBERATION (SPEAKER SLIPS MAY BE TURNED IN UNTIL THE ITEM IS CALLED FOR BUSINESS.)

**PUBLIC COMMENTS ON ANY SUBJECT NOT ON THE AGENDA UNDER THE
JURISDICTION OF THE CITY COUNCIL**

Those wishing to speak should complete and submit a BLUE speaker slip to the Bailiff. There is a three-minute time limit per person. All remarks and questions shall be addressed to the presiding officer or to the City Council and not to any individual Council member, staff member or other person.

AGENDA
February 26, 2013

JOINT CONSENT CALENDARS (SECTIONS A-D)

All items listed under the Consent Calendars, Sections A, B, C, and D are considered to be routine and non-controversial, and may be enacted by one motion unless a member of the City Council, Community Services District, City as Successor Agency for the Community Redevelopment Agency, Housing Authority or the Board of Library Trustees requests that an item be removed for separate action. The motion to adopt the Consent Calendars is deemed to be a separate motion by each Agency and shall be so recorded by the City Clerk. Items withdrawn for report or discussion will be heard after public hearing items.

A. CONSENT CALENDAR-CITY COUNCIL

A.1 ORDINANCES - READING BY TITLE ONLY

Recommendation: Waive reading of all Ordinances.

A.2 MINUTES - REGULAR MEETING OF FEBRUARY 12, 2013 (Report of: City Clerk's Department)

Recommendation:

1. Approve as submitted.

A.3 CITY COUNCIL REPORTS ON REIMBURSABLE ACTIVITIES (Report of: City Clerk's Department)

Recommendation:

1. Approve as submitted.

A.4 APPROVAL OF PAYMENT REGISTER FOR DECEMBER, 2012 (Report of: Financial & Management Services Department)

Recommendation:

1. Adopt Resolution No. 2013-12, approving the Payment Register for the month of December, 2012 in the amount of \$13,301,776.54.

Resolution No. 2013-12

A Resolution of the City Council of the City of Moreno Valley, California, Approving the Payment Register for the Month of December, 2012

A.5 RECEIPT OF QUARTERLY INVESTMENT REPORT – QUARTER ENDED DECEMBER 31, 2012

(Report of: Financial & Management Services Department)

Recommendation:

AGENDA
February 26, 2013

1. Receive and file the Quarterly Investment Report, in compliance with the City's Investment Policy.

A.6 APPROVE A RESOLUTION OF THE CITY COUNCIL OF THE CITY OF MORENO VALLEY, CALIFORNIA, TO AMEND THE ELECTRIC RATES FOR MORENO VALLEY UTILITY
(Report of: Public Works Department)

Recommendation:

1. Approve Resolution No. 2013-13 amending the Electric Rates for Moreno Valley Utility

Resolution No. 2013-13

A Resolution of the City Council of the City of Moreno Valley, California, to Amend the Electric Rates, and Electric Service Rules, Fees, and Charges for Moreno Valley Utility

A.7 APPROVE REIMBURSEMENT AGREEMENT FOR CONSTRUCTION OF ALTERNATE STREET SECTION OVER EASTERN MUNICIPAL WATER DISTRICT (EMWD) FACILITIES AS PART OF THE PERRIS BOULEVARD WIDENING FROM PERRIS VALLEY STORM DRAIN LATERAL "B" TO CACTUS AVENUE
PROJECT NO. 801 0022 70 77
(Report of: Public Works Department)

Recommendations

1. Approve the Reimbursement Agreement for Construction of an Alternate Street Section over Eastern Municipal Water District (EMWD) Facilities as part of the Perris Boulevard Widening from Perris Valley Storm Drain Lateral "B" to Cactus Avenue.
2. Authorize the City Manager to execute the Reimbursement Agreement for the amount of \$220,000, upon concurrence by EMWD.
3. Authorize the Public Works Director/City Engineer to execute any subsequent related amendments to the Agreement with EMWD up to, but not exceeding an additional amount of \$44,000.
4. Authorize a revenue appropriation of the amount of the EMWD reimbursement in Fund 3003 (TUMF Capital Projects) after the revenue is received from EMWD per the Reimbursement Agreement to fund the alternate street section segment construction.

A.8 APPROVE THE COOPERATIVE AGREEMENT WITH RIVERSIDE COUNTY FLOOD CONTROL AND WATER CONSERVATION DISTRICT

AGENDA
February 26, 2013

FOR THE MORENO MASTER DRAINAGE PLAN LINE F, STAGE 2, AND
AUTHORIZE THE APPROPRIATION OF FUNDS, PROJECT NO. 804
0005 70 77

(Report of: Public Works Department)

Recommendations

1. Approve the Cooperative Agreement with Riverside County Flood Control and Water Conservation District (the District) for the Moreno Master Drainage Plan Line F, Stage 2, subject to final acceptance of any changes by the City Manager and City Attorney, as well as approval of the appropriation of monies subject to the County Board of Supervisors approving the Cooperative Agreement and funding.
2. Authorize the City Manager to execute the Cooperative Agreement upon concurrence by the District.
3. Authorize the City Manager to approve any minor changes that may be requested by the District subject to the approval of the City Attorney.
4. Authorize the City Manager to execute any future amendments subject to the approval of the City Attorney.
5. Authorize the following appropriations: Revenue appropriation of up to \$4,000,000 (3002-99-99-93002); Expense appropriation of up to \$4,000,000 (3002-70-77-80004) in the Public Works General Capital Projects fund.

A.9 REPEAL RESOLUTION NO. 2010-58 ENERGY EFFICIENCY TARGETS
FOR MORENO VALLEY UTILITY AS MANDATED BY ASSEMBLY BILL
2021 AND ADOPT RESOLUTION NO. 2013-13 UPDATING ENERGY
EFFICIENCY TARGETS FOR MORENO VALLEY UTILITY

(Report of: Public Works Department)

Recommendation:

1. Repeal Resolution No. 2010-58 and Approve Resolution No. 2013-14 Adopting the 2013 Moreno Valley Utility Energy Efficiency Targets.

Resolution No. 2013-14

A Resolution of the City Council of the City of Moreno Valley, California, to Repeal Resolution No. 2010-58 Energy Efficiency Targets for Moreno Valley Utility and Adopt the Updated 2013 Energy Efficiency Targets for the Moreno Valley Electric Utility Mandated by Assembly Bill 2021

AGENDA
February 26, 2013

- A.10 SR 60 EAST CORRIDOR OVERLAY STUDY STATUS REPORT
(Report of: Community & Economic Development Department)

Recommendation:

1. Receive and file a status report for the SR 60 East Corridor Overlay Study.

- A.11 MONTHLY REPORT: MORENO VALLEY ANIMAL SHELTER ADOPTION RATE
(Report of: Administrative Services Department)

Recommendation:

1. Receive and file the Monthly Report: Moreno Valley Animal Shelter Adoption Rate for the period of January 1, 2013 to January 31, 2013.

- A.12 RESOLUTION OF THE CITY OF MORENO VALLEY SERVING AS THE SUCCESSOR AGENCY FOR THE COMMUNITY REDEVELOPMENT AGENCY OF THE CITY OF MORENO VALLEY APPROVING THE RECOGNIZED OBLIGATION PAYMENT SCHEDULE FOR THE PERIOD OF JULY 1, 2013 THROUGH DECEMBER 31, 2013
(Report of: Community & Economic Development Department)

Recommendations

1. Acting in the Capacity as the Successor Agency for the Community Redevelopment Agency of the City of Moreno Valley, Adopt Resolution No. SA 2013-02 approving a Recognized Obligation Payment Schedule (ROPS 13-14 A), for the period of July 1, 2013 through December 31, 2013.

Resolution No. SA 2013-02

A Resolution of the City Council of the City of Moreno Valley Serving as Successor Agency to the Community Redevelopment Agency of the City of Moreno Valley Approving the Recognized Obligation Payment Schedule for the Period of July 1, 2013 Through December 31, 2013, and Authorizing the Executive Director or his Designee to Make Modifications Thereto

2. Authorize the Executive Director or his designee to make modifications to the Schedule.
3. Authorize the transmittal of the ROPS 13-14 A to the Oversight Board for review and approval.

B. CONSENT CALENDAR-COMMUNITY SERVICES DISTRICT

AGENDA
February 26, 2013

B.1 ORDINANCES - READING BY TITLE ONLY
Recommendation: Waive reading of all Ordinances.

B.2 MINUTES - REGULAR MEETING OF FEBRUARY 12, 2013 (Report of:
City Clerk's Department)

Recommendation:
1. Approve as submitted.

C. CONSENT CALENDAR - HOUSING AUTHORITY

C.1 ORDINANCES - READING BY TITLE ONLY
Recommendation: Waive reading of all Ordinances.

C.2 MINUTES - REGULAR MEETING OF FEBRUARY 12, 2013 (Report of:
City Clerk's Department)

Recommendation:
1. Approve as submitted.

D. CONSENT CALENDAR - BOARD OF LIBRARY TRUSTEES

D.1 ORDINANCES - READING BY TITLE ONLY
Recommendation: Waive reading of all Ordinances.

D.2 MINUTES - REGULAR MEETING OF FEBRUARY 12, 2013 (Report of:
City Clerk's Department)

Recommendation:
1. Approve as submitted.

E. PUBLIC HEARINGS

Questions or comments from the public on a Public Hearing matter are limited to five minutes per individual and must pertain to the subject under consideration. Those wishing to speak should complete and submit a GOLDENROD speaker slip to the Bailiff.

E.1 PUBLIC HEARING TO ADOPT AN INTERIM URGENCY ORDINANCE OF THE CITY OF MORENO VALLEY, CALIFORNIA, MAKING FINDINGS AND EXTENDING A MORATORIUM ON THE ISSUANCE OF LAND USE ENTITLEMENT IN FOUR DESIGNATED LOCATIONS ALONG THE SR-60 EAST CORRIDOR AREA
(Report of: City Attorney Department)

Recommendations That the City Council:

AGENDA
February 26, 2013

1. Conduct a Public Hearing to allow the public an opportunity to comment on the proposed Interim Urgency Ordinance.
2. Adopt Interim Urgency Ordinance No. 861 making findings and extending a moratorium on the Issuance of Land Use Entitlements in four designated locations along the SR-60 East corridor area

Ordinance No. 861

An Interim Urgency Ordinance of the City of Moreno Valley, California, making findings and extending a moratorium on the Issuance of Land Use Entitlements in four designated locations along the SR-60 East corridor area.

F. ITEMS REMOVED FROM CONSENT CALENDARS FOR DISCUSSION OR SEPARATE ACTION

G. REPORTS

- G.1 APPROVE RESOLUTION NO. 2013-15 ESTABLISHING THE MAYOR'S AD HOC COMMITTEE ON INCREASING GRADUATION RATES
(Report of: City Manager Department)

Recommendations That the City Council:

1. Approve Resolution No. 2013-15 establishing a Mayor's Ad Hoc Committee on Increasing Graduation Rates.

Resolution No. 2013-15

A Resolution of the City Council of the City of Moreno Valley, California, Establishing A Mayor's Ad Hoc Committee on Increasing Graduation Rates

- G.2 APPROVE RESOLUTION NO. 2013-16 ESTABLISHING A CHARTER EXPLORATORY AD HOC SUBCOMMITTEE
(Report of: City Manager Department)

Recommendations That the City Council:

1. Approve Resolution No. 2013-16, establishing a Charter Exploratory Ad Hoc Subcommittee.

Resolution No. 2013-16

A Resolution of the City Council of the City of Moreno Valley, California, Establishing a Charter Exploratory Ad Hoc Subcommittee of the City Council

AGENDA
February 26, 2013

2. Appoint two members of the City Council to serve as the Ad Hoc Subcommittee tasked with drafting a city charter for the review of the full City Council and possible further action.

G.3 CITY MANAGER'S REPORT (Informational Oral Presentation - not for Council action)

G.3.1 PARKS AND COMMUNITY SERVICES DEPARTMENT UPDATE (POWERPOINT PRESENTATION)

G.4 CITY ATTORNEY'S REPORT (Informational Oral Presentation - not for Council action)

H. LEGISLATIVE ACTIONS

H.1 ORDINANCES - 1ST READING AND INTRODUCTION - NONE

H.2 ORDINANCES - 2ND READING AND ADOPTION

H.2.1 AN ORDINANCE OF THE CITY COUNCIL OF THE CITY OF MORENO VALLEY, CALIFORNIA, AMENDING TITLE 2 OF THE CITY OF MORENO VALLEY MUNICIPAL CODE, BY ADDING A NEW CHAPTER 2.64, CREATING A JULY 4TH ADVISORY BOARD (RECEIVED FIRST READING AND INTRODUCTION BY A 5-0 VOTE) (Report of: Parks & Community Services Department)

Recommendations That the City Council:

1. Adopt Ordinance No. 860, an Ordinance of the City of Moreno Valley, California, amending Title 2 of the City of Moreno Valley Municipal Code, by adding a new Chapter 2.64, creating a July 4th Advisory Board.

Ordinance No. 860

An Ordinance of the City Council of the City of Moreno Valley, California, Amending Title 2 of the City of Moreno Valley Municipal Code, by Adding A New Chapter 2.64, Creating a July 4th Advisory Board

H.3 ORDINANCES - URGENCY ORDINANCES - NONE

H.4 RESOLUTIONS - NONE

**CLOSING COMMENTS AND/OR REPORTS OF THE CITY COUNCIL,
COMMUNITY SERVICES DISTRICT, CITY AS SUCCESSOR AGENCY FOR THE**

AGENDA

February 26, 2013

COMMUNITY REDEVELOPMENT AGENCY OR HOUSING AUTHORITY

Materials related to an item on this Agenda submitted to the City Council/Community Services District/City as Successor Agency for the Community Redevelopment Agency/Housing Authority or the Board of Library Trustees after distribution of the agenda packet are available for public inspection in the City Clerk's office at 14177 Frederick Street during normal business hours.

CLOSED SESSION

A Closed Session of the City Council, Community Services District, City as Successor Agency for the Community Redevelopment Agency and Housing Authority will be held in the City Manager's Conference Room, Second Floor, City Hall. The City Council will meet in Closed Session to confer with its legal counsel regarding the following matter(s) and any additional matter(s) publicly and orally announced by the City Attorney in the Council Chamber at the time of convening the Closed Session.

- **PUBLIC COMMENTS ON MATTERS ON THE CLOSED SESSION AGENDA UNDER THE JURISDICTION OF THE CITY COUNCIL**

There is a three-minute time limit per person. Please complete and submit a BLUE speaker slip to the City Clerk. All remarks and questions shall be addressed to the presiding officer or to the City Council and not to any individual Council member, staff member or other person.

The Closed Session will be held pursuant to Government Code:

1 SECTION 54956.9(b)(1) - CONFERENCE WITH LEGAL COUNSEL -
SIGNIFICANT EXPOSURE TO LITIGATION

Number of Cases: 5

2 SECTION 54956.9(c) - CONFERENCE WITH LEGAL COUNSEL -
INITIATION OF LITIGATION

Number of Cases: 5

REPORT OF ACTION FROM CLOSED SESSION, IF ANY, BY CITY ATTORNEY

ADJOURNMENT

CERTIFICATION

I, Jane Halstead, City Clerk of the City of Moreno Valley, California, certify that the City Council Agenda was posted in the following places pursuant to City of Moreno Valley Resolution No. 2007-40:

City Hall, City of Moreno Valley
14177 Frederick Street

AGENDA
February 26, 2013

Moreno Valley Library
25480 Alessandro Boulevard

Moreno Valley Senior/Community Center
25075 Fir Avenue

Jane Halstead, CMC,
City Clerk

Date Posted: 2/20/2013

MINUTES
CITY COUNCIL REGULAR MEETING OF THE CITY OF MORENO VALLEY
February 12, 2013

CALL TO ORDER

SPECIAL PRESENTATIONS

1. NAIOP Commercial Real Estate Development Association – Inland Empire Chapter Award Presentation to City of Moreno Valley as Public Partner of the Year 2012
2. Recognition of Shor Denny, Program Coordinator, Moreno Valley Safe Routes to School
3. Business Spotlight
 - a) Steer 'n Stein Restaurant
 - b) Office Depot

**MINUTES
JOINT MEETING OF THE
CITY COUNCIL OF THE CITY OF MORENO VALLEY
MORENO VALLEY COMMUNITY SERVICES DISTRICT
CITY AS SUCCESSOR AGENCY FOR THE
COMMUNITY REDEVELOPMENT AGENCY OF
THE CITY OF MORENO VALLEY
MORENO VALLEY HOUSING AUTHORITY
BOARD OF LIBRARY TRUSTEES**

**REGULAR MEETING – 6:30 PM
February 12, 2013**

CALL TO ORDER

The Joint Meeting of the City Council of the City of Moreno Valley, Moreno Valley Community Services District, City as Successor Agency for the Community Redevelopment Agency of the City of Moreno Valley, Moreno Valley Housing Authority and the Board of Library Trustees was called to order at 6:31 p.m. by Mayor Tom Owings in the Council Chamber located at 14177 Frederick Street.

Mayor Tom Owings announced that the City Council receives a separate stipend for CSD meetings.

PLEDGE OF ALLEGIANCE

The Pledge of Allegiance was led by Shor Denny.

INVOCATION - Captain Julius Murphy, The Salvation Army - Moreno Valley Corp

ROLL CALL

Council:

Tom Owings	Mayor
Victoria Baca	Council Member
Jesse L. Molina	Council Member
Richard A. Stewart	Council Member (left at 8:20 p.m.)

Absent:

Marcelo Co	Mayor Pro Tem
------------	---------------

Staff:

Jane Halstead	City Clerk
Ewa Lopez	Deputy City Clerk
Henry T. Garcia	City Manager

MINUTES
February 12, 2013

Richard Teichert
Suzanne Bryant
Michelle Dawson
Joel Ontiveros
Abdul Ahmad
Ahmad Ansari
Barry Foster
Tom DeSantis
Mike McCarty

Financial and Management Services Director
Acting City Attorney
Assistant City Manager
Police Chief
Fire Chief
Public Works Director
Community and Economic Development Director
Administrative Services Director
Parks & Community Services Director

JOINT CONSENT CALENDARS (SECTIONS A-D) OF THE CITY COUNCIL OF THE CITY OF MORENO VALLEY, MORENO VALLEY COMMUNITY SERVICES DISTRICT, COMMUNITY REDEVELOPMENT AGENCY OF THE CITY OF MORENO VALLEY AND THE BOARD OF LIBRARY TRUSTEES

Mayor Tom Owings opened the agenda items for the Consent Calendars for public comments, which were received from Pete Bleckert (Item A.3, Chamber of Commerce).

A. CONSENT CALENDAR-CITY COUNCIL

A.1 ORDINANCES - READING BY TITLE ONLY

Recommendation: Waive reading of all Ordinances.

A.2 MINUTES - REGULAR MEETING OF JANUARY 22, 2013 (Report of: City Clerk's Department)

Recommendations

Approve as submitted.

A.3 CITY COUNCIL REPORTS ON REIMBURSABLE ACTIVITIES (Report of: City Clerk's Department)

Recommendations

Approve as submitted.

B. CONSENT CALENDAR-COMMUNITY SERVICES DISTRICT

B.1 ORDINANCES - READING BY TITLE ONLY

Recommendation: Waive reading of all Ordinances.

B.2 MINUTES - REGULAR MEETING OF JANUARY 22, 2013 (Report of: City Clerk's Department)

Recommendation:

Approve as submitted.

MINUTES
February 12, 2013

C. CONSENT CALENDAR - HOUSING AUTHORITY

C.1 ORDINANCES - READING BY TITLE ONLY

Recommendation: Waive reading of all Ordinances.

C.2 MINUTES - REGULAR MEETING OF JANUARY 22, 2013 (Report of: City Clerk's Department)

Recommendation:

Approve as submitted.

D. CONSENT CALENDAR - BOARD OF LIBRARY TRUSTEES

D.1 ORDINANCES - READING BY TITLE ONLY

Recommendation: Waive reading of all Ordinances.

D.2 MINUTES - REGULAR MEETING OF JANUARY 22, 2013 (Report of: City Clerk's Department)

Recommendation:

Approve as submitted.

Motion to Approve Joint Consent Calendar Items A.1 through D.2 by m/Council Member Jesse L. Molina, s/Council Member Victoria Baca

Approved by a vote of 4-0-1, Mayor Pro Tem Marcelo Co absent.

E. PUBLIC HEARINGS - None

F. ITEMS REMOVED FROM CONSENT CALENDARS FOR DISCUSSION OR SEPARATE ACTION

G. REPORTS

G.1 PROPOSED RESOLUTION AMENDING THE RULES OF PROCEDURE FOR CITY COUNCIL MEETINGS AND RELATED FUNCTIONS AND ACTIVITIES (ITEM CONTINUED FROM JANUARY 22, 2013, BY A 5-0 VOTE)

(Report of: City Manager Department)

Recommendations That the City Council:

1. Adopt Resolution No. 2013-10 repealing Resolution No. 2011-117 and adopting amended and restated Rules of Procedure for Council Meetings and Related Functions and Activities.

MINUTES
February 12, 2013

Resolution No. 2013-10

A Resolution of the City Council of the City of Moreno Valley, California, Repealing Resolution 2011-117, and Adopting Amended and Restated Rules of Procedure for City Council Meetings and Related Functions and Activities

2. Approve a change in practice and direct staff to begin televising City Council study sessions.

Mayor Tom Owings opened the agenda item for public comments, which were received from Deanna Reeder and Tom Jerele Sr (supports).

Motion to Approve by m/Council Member Richard A. Stewart, s/Council Member Jesse L. Molina

Approved by a vote of 4-0-1, Mayor Pro Tem Marcelo Co absent.

- G.2 APPROVE A RESOLUTION OF THE SUCCESSOR AGENCY TO THE COMMUNITY REDEVELOPMENT AGENCY OF THE CITY OF MORENO VALLEY AUTHORIZING THE TRANSFER OF THE REMAINING BOND PROCEEDS FROM THE 2007 TAX ALLOCATION BONDS SERIES A FROM THE SUCCESSOR AGENCY TO THE CITY OF MORENO VALLEY TO COMPLETE THE REMAINING BOND FUNDED PROJECTS
(Report of: Financial & Management Services Department)

Recommendations That the City Council:

Acting in their capacity as the Successor Agency, approve Resolution No. SA 2013-01 authorizing and directing the transfer of all remaining bond proceeds from the 2007 Tax Allocation Bonds, Series A, from the Successor Agency to the City of Moreno Valley to complete the remaining bond funded projects.

Resolution No. SA 2013-01

A Resolution Of The Successor Agency To The Community Redevelopment Agency Of The City Of Moreno Valley Authorizing The Transfer Of All Remaining Bond Proceeds From The 2007 Tax Allocation Bonds Series A From The Successor Agency To The City Of Moreno Valley To Complete The Remaining Bond Funded Projects

Mayor Tom Owings opened the agenda item for public comments, which were received from Deanna Reeder (opposes), and Pete Bleckert.

Motion to Approve by m/Council Member Richard A. Stewart, s/Council Member Jesse L. Molina

MINUTES
February 12, 2013

Approved by a vote of 4-0-1, Mayor Pro Tem Marcelo Co absent.

- G.3 APPROVE A RESOLUTION OF THE CITY OF MORENO VALLEY AUTHORIZING THE RECEIPT OF THE REMAINING BOND PROCEEDS FROM THE 2007 TAX ALLOCATION BONDS SERIES A FROM THE SUCCESSOR AGENCY TO COMPLETE THE BOND FUNDED PROJECTS AND AUTHORIZING THE ESTABLISHMENT OF THE REQUIRED FUNDS AND ACCOUNTS FOR ACCOUNTING PURPOSES
(Report of: Financial & Management Services Department)

Recommendations That the City Council:

Approve Resolution No. 2013-11 authorizing the receipt of remaining bond proceeds from the 2007 Tax Allocation Bonds, Series A, from the Successor Agency of the Community Redevelopment Agency of the City of Moreno Valley, and direct the City to complete the remaining bond funded projects and authorizing and directing staff to establish all funds and accounts necessary to record and report on the expenditure of bond proceeds for accounting purposes.

Resolution No. 2013-11

A Resolution Of The City Council Of The City Of Moreno Valley, California, Authorizing The Receipt Of Remaining Bond Proceeds From The 2007 Tax Allocation Bonds Series A From The Successor Agency To Complete The Remaining Bond Funded Projects And Authorizing The Establishment Of The Required Funds And Accounts For Accounting Purposes

Mayor Tom Owings opened the agenda item for public comments, which were received from Pete Bleckert.

Motion to Approve by m/Council Member Richard A. Stewart, s/Council Member Victoria Baca

Approved by a vote of 4-0-1, Mayor Pro Tem Marcelo Co absent.

- G.4 RECEIVE AND FILE A REPORT DISCUSSING THE STATE DEPARTMENT OF FINANCE'S DETERMINATION OF THE SUCCESSOR AGENCY OF THE COMMUNITY REDEVELOPMENT AGENCY OF THE CITY OF MORENO VALLEY'S LOW AND MODERATE INCOME HOUSING FUNDS
(Report of: Financial & Management Services Department)

Recommendations That the City Council:

Receive and file the staff report discussing the State Department of Finance's Determination of the Successor Agency of the Community

MINUTES
February 12, 2013

Redevelopment Agency of the City of Moreno Valley's low and moderate income housing funds.

Mayor Tom Owings opened the agenda item for public comments, which were received from Pete Bleckert and Deanna Reeder.

Council Member Richard A. Stewart left at 8:20 p.m.

Motion to Approve by m/Council Member Jesse L. Molina, s/Council Member Victoria Baca

Approved by a vote of 3-0-2, Mayor Pro Tem Marcelo Co, and Council Member Richard A. Stewart absent.

G.5 CITY ATTORNEY'S REPORT (Informational Oral Presentation - not for Council action) - none

G.6 CITY MANAGER'S REPORT (Informational Oral Presentation - not for Council action) - none

H. LEGISLATIVE ACTIONS

H.1 ORDINANCES - 1ST READING AND INTRODUCTION

H.1.1 AN ORDINANCE OF THE CITY COUNCIL OF THE CITY OF MORENO VALLEY, CALIFORNIA, AMENDING TITLE 2 OF THE CITY OF MORENO VALLEY MUNICIPAL CODE, BY ADDING A NEW CHAPTER 2.64, CREATING A JULY 4TH ADVISORY BOARD (Report of: Parks & Community Services Department)

Recommendations That the City Council:

Introduce Ordinance No. 860, an Ordinance of the City of Moreno Valley, California, amending Title 2 of the City of Moreno Valley Municipal Code, by adding a new Chapter 2.64, creating a July 4th Advisory Board.

Ordinance No. 860

An Ordinance Of The City Council Of The City Of Moreno Valley, California, Amending Title 2 Of The City Of Moreno Valley Municipal Code, By Adding A New Chapter 2.64, Creating A July 4th Advisory Board

Mayor Tom Owings opened the agenda item for public comments, which were received from Scott Heveran, Tom Jerele Sr. (supports), Julie Ann Stewart-Cleaveland, and Cody Gonzalez.

MINUTES
February 12, 2013

Recess;

Reconvened

Motion to Approve by m/Council Member Jesse L. Molina, s/Council Member Victoria Baca

Approved by a vote of 3-0-2, Mayor Pro Tem Marcelo Co, and Council Member Richard A. Stewart absent.

H.2 ORDINANCES - 2ND READING AND ADOPTION - NONE

H.3 ORDINANCES - URGENCY ORDINANCES - NONE

H.4 RESOLUTIONS - NONE

PUBLIC COMMENTS **ON ANY SUBJECT NOT ON THE AGENDA** UNDER THE JURISDICTION OF THE CITY COUNCIL

Scott Heveran

1. Thanked for televising study sessions
2. The need to educate and involve voters
3. Format for debates

Daryl Terrell

1. Money spent in politics; proposed campaign finance reform plan

Deanna Reeder

1. Lawsuit, which was mentioned at the February 2, 2013 special meeting, regarding financing of Nason Street improvements

Tom Jerele Sr.

1. Thanked Mayor Owings and Council Member Molina for supporting Sundance shopping center
2. Scot Robinson's anti-drugs and anti-drinking presentation at Vista del Lago High School
3. Ideas for 4th of July celebration

MINUTES
February 12, 2013

Pete Bleckert

1. RDA development
2. City's spending/contribution to the Chamber of Commerce
3. Campaign contributions received by Council Members

Cody Gonzales

1. Thanked the Council for approving creation of 4th of July Advisory Board
2. Asked to amend the ordinance to include two youth members (15 to 25 years old), instead of two teen members

**CLOSING COMMENTS AND/OR REPORTS OF THE CITY COUNCIL,
COMMUNITY SERVICES DISTRICT, CITY AS SUCCESSOR AGENCY FOR THE
COMMUNITY REDEVELOPMENT AGENCY OR HOUSING AUTHORITY**

Council Member Victoria Baca

1. Attended Vision Warrior Academy at Vista del Lago High School; second presentation for the parents will be held on February 13; encouraged parents to attend; it is important for parents to know what is going on in their children lives; many parents don't know what that means to be addicted
2. Pleased that July 4th Advisory Board was approved by the City Council; encouraged residents to volunteer

Council Member Jesse L. Molina

1. Attended actor Scot Robinson's Vision Warrior event – the actor is trying to make connection with kids; very interesting and convincing
2. Reminded everyone that February is a Black History month; many churches and organizations hold celebrations
3. Go Pass for Moreno Valley campus – asked to take advantage of it; it provides mobility; unfortunately, it didn't make a ballot; six thousand students were eligible for the program, but only 1,400 voted; is trying to get back the program
4. Today, attended the Black History Month celebration at the Senior Center

Mayor Tom Owings

1. Riverside Hillside Association is suing to block the Metrolink in Perris; encouraged citizens to call in support of this program; this program will

MINUTES
February 12, 2013

take 350,000 cars a day out of our freeway

3. Moreno Valley Animal Shelter will be holding a Valentine's Day Pet Adoption event on February 13, offering special discounted adoption prices; encouraged residents to adopt a pet from the shelter; information is available on the City's Web site

CLOSED SESSION - none

ADJOURNMENT

Motion to Approve by m/Council Member Jesse L. Molina, s/Council Member Victoria Baca

Approved by a vote of 3-0-2, Mayor Pro Tem Marcelo Co, and Council Member Richard A. Stewart absent.

There being no further business to conduct, the meeting was adjourned at 10:15 p.m. by unanimous informal consent.

Submitted by:

City Clerk Jane Halstead, City Clerk, CMC
Secretary, Moreno Valley Community Services District
Secretary, City as Successor Agency for the Community Redevelopment Agency of the City of Moreno Valley
Secretary, Moreno Valley Housing Authority
Secretary, Board of Library Trustees

Approved by:

Council Member Richard A. Stewart
President, Moreno Valley Community Services District
Chairperson, City as Successor Agency of the Community Redevelopment Agency of the City of Moreno Valley
Chairperson, Moreno Valley Housing Authority
Chairperson, Board of Library Trustees

enl

MINUTES
February 12, 2013



Report to City Council

TO: Mayor and City Council

FROM: Jane Halstead, City Clerk

AGENDA DATE: February 26, 2013

TITLE: CITY COUNCIL REPORTS ON REIMBURSABLE ACTIVITIES

RECOMMENDED ACTION

Recommendation:

1. Receive and file the Reports on Reimbursable Activities for the period of February 6-19, 2013.

<i>Reports on Reimbursable Activities</i>			
February 6-19, 2013			
Council Member	Date	Meeting	Cost
Victoria Baca		None	
Marcelo Co		None	
Jesse L. Molina	2/13/13	Student of the Month	\$15.00
Tom Owings		None	
Richard A. Stewart		None	

Prepared By:
Cindy Miller
Executive Assistant to the Mayor/City Council

Department Head Approval:
Jane Halstead
City Clerk

Council Action	
Approved as requested:	Referred to:
Approved as amended:	For:
Denied:	Continued until:
Other:	Hearing set for:

\\Zurich\shared\InterDept\Council-Clerk\City Clerk Files\Council Office\AB 1234 Reports\2013\Staff Report 2013_Reimbursable Activity 022613.doc

This page intentionally left blank.



APPROVALS	
BUDGET OFFICER	<i>[Signature]</i>
CITY ATTORNEY	<i>[Signature]</i>
CITY MANAGER	<i>[Signature]</i>

Report to City Council

TO: Mayor and City Council

FROM: Richard Teichert, Financial & Management Services Director

AGENDA DATE: February 26, 2013

TITLE: APPROVAL OF PAYMENT REGISTER FOR DECEMBER, 2012

RECOMMENDED ACTION

Recommendation:

1. Adopt Resolution No. 2013-12, approving the Payment Register for the month of December, 2012 in the amount of \$13,301,776.54. Resolution No. 2013-12 - A Resolution of the City Council of the City of Moreno Valley, California, Approving the Payment Register for the Month of December, 2012

DISCUSSION

The payment register has been revised to incorporate additional data while still using a standard format from the City's new LOGOS General Ledger system. This revised format provides the following:

1. Lists all issued checks and electronic fund transfers (EFT) for the month, thus eliminating the need for a separate fund transfer register;
2. Created two categories for all payments:
 - a. Category A: Checks/EFTs in the amount of \$25,000 or greater; and
 - b. Category B: Checks/EFTs under \$25,000;
3. If a vendor was issued a check/EFT in the amount of \$25,000 or greater, all checks issued to the vendor for the month are listed in Category A;
4. Lists all payments by vendor in alphabetical order;
5. Provides City and State information of vendor.

Staff continues to work on possible alternate sorting options and solutions as we become fully operational with the features of the new system.

FISCAL IMPACT

The disbursements itemized in the attached Payment Register are reflected in the FY 2012-13 budget. Therefore, there is no fiscal impact other than the expenditure of budgeted funds.

ATTACHMENTS

Attachment 1: Proposed Resolution

Attachment 2: Payment Register for Month of December, 2012

Prepared By:
Dena Heald
Acting Financial Operations Division Manager

Department Head Approval:
Richard Teichert
Financial & Management Services Director

Council Action	
Approved as requested:	Referred to:
Approved as amended:	For:
Denied:	Continued until:
Other:	Hearing set for:

RESOLUTION NO. 2013-12

A RESOLUTION OF THE CITY COUNCIL OF THE CITY OF MORENO VALLEY, CALIFORNIA, APPROVING THE PAYMENT REGISTER FOR THE MONTH OF DECEMBER, 2012

WHEREAS, the Financial & Management Services Department has prepared and provided the Payment Register for the period December 1, 2012 through December 31, 2012, for review and approval by the City Council of the City of Moreno Valley; and

WHEREAS, it is in the best interest of the City that the referenced Payment Register be approved.

NOW, THEREFORE, IT IS HEREBY RESOLVED BY THE CITY COUNCIL OF THE CITY OF MORENO VALLEY, CALIFORNIA, that the Payment Register for the period December 1, 2012 through December 31, 2012, in the total amount of \$13,301,776.54 is approved.

APPROVED AND ADOPTED this 26th day of February, 2013.

Mayor

ATTEST:

City Clerk

APPROVED AS TO FORM:

City Attorney

1
Resolution No. 2013-12
Date Adopted: February 26, 2013

RESOLUTION JURAT

STATE OF CALIFORNIA)
COUNTY OF RIVERSIDE) ss.
CITY OF MORENO VALLEY)

I, Jane Halstead, City Clerk of the City of Moreno Valley, California, do hereby certify that Resolution No. 2013-12 was duly and regularly adopted by the City Council of the City of Moreno Valley at a regular meeting thereof held on the 26th day of February, 2013 by the following vote:

AYES:

NOES:

ABSENT:

ABSTAIN:

CITY CLERK

Resolution No. 2013-12²
Date Adopted: February 26, 2013



City of Moreno Valley
Payment Register
 For Period 12/1/2012 through 12/31/2012

CHECKS IN THE AMOUNT OF \$25,000 OR GREATER

<u>Vendor Name</u>	<u>Check/EFT Number</u>	<u>Payment Date</u>	<u>Invoice Number</u>	<u>Invoice Description</u>	<u>Amount</u>	<u>FYTD</u>
AECOM TECHNICAL SERVICES INC	215453	12/20/2012	37275273	CONSULTING SERVICES, ENGINEERING - INDIAN BASIN IMPROVEMENTS	\$85,387.98	
				Remit to: ONTARIO, CA	\$85,387.98	\$85,387.98
C P CONSTRUCTION CO., INC.	215245	12/10/2012	14919	CONSTRUCTION CONTRACT - CORPORATE YARD SEWER	\$32,324.73	
				Remit to: ONTARIO, CA	\$32,324.73	\$218,594.86
COUNTY OF RIVERSIDE SHERIFF	8008	12/03/2012	SH0000020109	CONTRACT LAW ENFORCEMENT BILLING #3 (8/23-9/19/12)	\$2,601,967.60	
				Remit to: RIVERSIDE, CA	\$2,601,967.60	\$16,448,270.42
COUNTY OF RIVERSIDE, AUDITOR-CONTROLLER	215361	12/17/2012	SEPT-12	TRANSMITTAL OF AB544-PARKING CONTROL FEES	\$21,105.38	
			OCT-12	TRANSMITTAL OF AB544-PARKING CONTROL FEES	\$23,567.50	
				Remit to: RIVERSIDE, CA	\$44,672.88	\$79,664.46
E M W D	215460	12/20/2012	NOV-12 12/20/12	WATER CHARGES	\$43,654.93	
				Remit to: PERRIS, CA	\$43,654.93	\$703,687.34
ELITE COMPANIES US, INC.	215252	12/10/2012	10292012	CONSTRUCTION CONTRACT - HEACOCK STREET SIDEWALK IMPROVEMENTS	\$30,911.23	
				Remit to: HUNTINGTON BEACH, CA	\$30,911.23	\$47,174.74
EMPLOYMENT DEVELOPMENT DEPARTMENT	8183	12/14/2012	S121213	3207-STATE INCOME TAX DEPOSIT	\$35,765.04	
				Remit to: WEST SACRAMENTO, CA	\$35,765.04	\$487,285.36
EMPLOYMENT DEVELOPMENT DEPARTMENT	8294	12/28/2012	S121227	3215-STATE INCOME TAX DEPOSIT	\$36,022.70	

Item No. A.4

-29-



City of Moreno Valley
Payment Register
 For Period 12/1/2012 through 12/31/2012

CHECKS IN THE AMOUNT OF \$25,000 OR GREATER

<u>Vendor Name</u>	<u>Check/EFT Number</u>	<u>Payment Date</u>	<u>Invoice Number</u>	<u>Invoice Description</u>	<u>Amount</u>	<u>FYTD</u>
				Remit to: WEST SACRAMENTO, CA	\$36,022.70	\$487,285.36
FALCON ENGINEERING SERVICES, INC	215462	12/20/2012	2012-02REV	CONSULTING SERVICES, ENGINEERING	\$5,940.00	
			2012-04REV-A	CONSULTING SERVICES, ENGINEERING - MORENO BEACH PH I	\$45,579.39	
			2012-02-A	CONSULTING SERVICES, ENGINEERING - MORENO BEACH PH I	\$11,556.50	
			2012-03REV-A	CONSULTING SERVICES, ENGINEERING - MORENO BEACH PH I	\$9,747.20	
				Remit to: CORONA, CA	\$72,823.09	\$80,810.51
FOOD SERVICES OF MVUSD	215463	12/20/2012	4792	AFTER SCHOOL SNACKS-SEPT12	\$32,253.64	
			4793	AFTER SCHOOL SNACKS-OCT12	\$37,407.20	
			4786	AFTER SCHOOL SNACKS-AUG12	\$16,109.72	
				Remit to: MORENO VALLEY, CA	\$85,770.56	\$85,770.56
HILLCREST CONTRACTING, INC	8057	12/10/2012	PB 22135	CONSTRUCTION CONTRACT - PERRIS BLVD. IMPROVEMENTS	\$416,008.47	
				Remit to: CORONA, CA	\$416,008.47	\$1,339,372.85
IHERB, INC	8221	12/20/2012	W121206	PARTICIPATION AGREEMENT-NEW BUSINESS INCENTIVE PROG.	\$50,000.00	
				Remit to: MORENO VALLEY, CA	\$50,000.00	\$50,000.00
INTERNAL REVENUE SERVICE	8182	12/14/2012	F121213	3206-FEDERAL INCOME TAX DEPOSIT	\$137,162.92	
				Remit to: SACRAMENTO, CA	\$137,162.92	\$1,704,354.93
INTERNAL REVENUE SERVICE	8293	12/28/2012	F121227	3214-FEDERAL INCOME TAX DEPOSIT	\$137,514.89	
				Remit to: SACRAMENTO, CA	\$137,514.89	\$1,704,354.93

-30-



**City of Moreno Valley
Payment Register
For Period 12/1/2012 through 12/31/2012**

CHECKS IN THE AMOUNT OF \$25,000 OR GREATER

<u>Vendor Name</u>	<u>Check/EFT Number</u>	<u>Payment Date</u>	<u>Invoice Number</u>	<u>Invoice Description</u>	<u>Amount</u>	<u>FYTD</u>
KIP INCORPORATED	215369	12/17/2012	6919	CONSTRUCTION CONTRACT - HEACOCK STREET BRIDGE	\$518,907.48	
				Remit to: MURRIETA, CA	\$518,907.48	\$1,491,209.2
LAWYERS TITLE COMPANY	8173	12/11/2012	W121202	LAND ACQUISITION-MORENO VALLEY INTERCHANGE PROJ-APN473-160-008	\$29,290.00	
				Remit to: NEWPORT BEACH, CA	\$29,290.00	\$239,312.50
MARIPOSA HORTICULTURAL	8019	12/03/2012	57259	LANDSCAPE MAINT-ZONE DSG-2-ADDL WORK-OCT12	\$1,297.07	
			57260	LANDSCAPE MAINT-ZONE DSG-2-OCT12	\$12,857.13	
			56775	LANDSCAPE MAINT-DSG2-SEPT12	\$12,857.13	
				Remit to: IRWINDALE, CA	\$27,011.33	\$102,301.21
MORENO VALLEY UTILITY	215371	12/17/2012	7013411-01/NOV12	ELECTRICITY-UTILITY FIELD OFFICE	\$82.66	
			DEC-12 12/12/12	ELECTRICITY	\$51,224.88	
				Remit to: HEMET, CA	\$51,307.54	\$458,122.33
MOSS BROS. AUTOGROUP	8224	12/20/2012	W121207	PARTICIPATION AGREEMENT-FINAL PAYMENT	\$250,000.00	
				Remit to: RIVERSIDE, CA	\$250,000.00	\$250,000.00
MV HEMLOCK LIMITED PARTNERSHIP	8222	12/20/2012	W121208	FIRST DISBURSEMENT OF HOME FUND	\$400,000.00	
				Remit to: RIVERSIDE, CA	\$400,000.00	\$400,000.00
NATIONWIDE RETIREMENT SOLUTIONS	8179	12/13/2012	NW457121213	3203-DEFERRED COMP-457 & 401A	\$27,124.75	
				Remit to: COLUMBUS, OH	\$27,124.75	\$335,812.83
NATIONWIDE RETIREMENT SOLUTIONS	8297	12/27/2012	NW457121227	3211-DEFERRED COMP-457 & 401A	\$27,043.62	

Item No. A.4

-31-



City of Moreno Valley
Payment Register
 For Period 12/1/2012 through 12/31/2012

CHECKS IN THE AMOUNT OF \$25,000 OR GREATER

<u>Vendor Name</u>	<u>Check/EFT Number</u>	<u>Payment Date</u>	<u>Invoice Number</u>	<u>Invoice Description</u>	<u>Amount</u>	<u>FYTD</u>
				Remit to: COLUMBUS, OH	\$27,043.62	\$335,812.83
NEW WORLD SYSTEMS, CORP.	8148	12/17/2012	024217	MILESTONE BILLING-ERP REPLACEMENT PROJECT	\$42,200.00	
			024335	TRAVEL TIME-ERP REPLACEMENT PROJECT	\$600.00	
			024260	TRAVEL EXPENSES-ERP REPLACEMENT PROJECT	\$1,615.43	
			024186	TRAVEL EXPENSES-ERP REPLACEMENT PROJECT	\$2,668.31	
				Remit to: TROY, MI	\$47,083.74	\$200,568.99
NOBLE AMERICAS ENERGY SOLUTIONS	8203	12/20/2012	123460002703097	ELECTRIC ENERGY PURCHASE FOR MV UTILITY	\$258,915.26	
				Remit to: PASADENA, CA	\$258,915.26	\$1,766,502.68
OPTUS, INC	215373	12/17/2012	TQJ181822	NEC IP SIP TELEPHONES ORDER	\$7,926.09	
			TQJ181960	NEC IP SIP TELEPHONES ORDER	\$31,833.66	
				Remit to: JONESBORO, AZ	\$39,759.75	\$39,759.75
PERS HEALTH INSURANCE	8174	12/07/2012	W121203	EMPLOYEE HEALTH INSURANCE	\$194,297.73	
				Remit to: SACRAMENTO, CA	\$194,297.73	\$1,166,249.81
PERS RETIREMENT	8330	12/07/2012	P121123	3200-PERS RETIREMENT	\$238,813.57	
				Remit to: SACRAMENTO, CA	\$238,813.57	\$3,050,765.68
PERS RETIREMENT	8331	12/21/2012	P121207	3207-PERS RETIREMENT	\$239,979.63	
				Remit to: SACRAMENTO, CA	\$239,979.63	\$3,050,765.68
R.I.C. CONSTRUCTION CO., INC.	8149	12/17/2012	45550	ANNEX 1 TENANT IMPROVEMENTS PROJECT SVCS	\$257,971.18	

-32-



**City of Moreno Valley
Payment Register
For Period 12/1/2012 through 12/31/2012**

CHECKS IN THE AMOUNT OF \$25,000 OR GREATER

<u>Vendor Name</u>	<u>Check/EFT Number</u>	<u>Payment Date</u>	<u>Invoice Number</u>	<u>Invoice Description</u>	<u>Amount</u>	<u>FYTD</u>
				Remit to: HESPERIA, CA	\$257,971.18	\$491,306.9
RIVERSIDE COUNTY SHERIFF	215250	12/10/2012	SH0000020443	LAW ENFORCEMENT SVCS-2010 JAG GRANT	\$12,468.04	
			SH0000020370	REIMB FOR RCRMC SEXUAL ASSAULT EXAMS BILLED TO COUNTY	\$11,700.00	
			SH0000020442	LAW ENFORCEMENT SVCS-2010 JAG GRANT	\$10,892.27	
			SH0000020441	LAW ENFORCEMENT SVCS-2010 JAG GRANT	\$4,672.01	
				Remit to: MORENO VALLEY, CA	\$39,732.32	\$196,882.97
SHELL ENERGY NORTH AMERICA (US) L.P.	8153	12/17/2012	1150560	ELECTRIC ENERGY PURCHASE FOR MV UTILITY	\$434,106.40	
				Remit to: PHILADELPHIA, PA	\$434,106.40	\$3,365,695.20
SOUTHERN CALIFORNIA EDISON	215276	12/10/2012	7500226416	WDAT CHARGES-FREDERICK AVE. LOCATION	\$2,875.05	
			7500226415	WDAT CHARGES-NANDINA AVE. LOCATION	\$2,647.31	
			7500226414	WDAT CHARGES-GLOBE ST. LOCATION	\$9,808.92	
			7500226413	WDAT CHARGES-GRAHAM ST. LOCATION	\$6,078.69	
			7500226411	WDAT CHARGES-IRIS AVE. LOCATION	\$4,422.29	
				Remit to: ROSEMEAD, CA	\$25,832.26	\$231,553.58
SOUTHERN CALIFORNIA EDISON	215382	12/17/2012	707-6081 NOV-12	ELECTRICITY	\$400.23	
			721-3449 NOV-12	IFA CHARGES-SUBSTATION	\$14,146.73	
			587-9520 NOV-12	ELECTRICITY-FERC CHARGES	\$701.48	
			NOV-12 12/17/12	ELECTRICITY	\$107,764.31	
				Remit to: ROSEMEAD, CA	\$123,012.75	\$1,143,324.31
SOUTHERN CALIFORNIA EDISON	215473	12/20/2012	NOV-12 12/20/12	ELECTRICITY	\$59,644.47	

Item No. A.4

-33-



City of Moreno Valley
Payment Register
 For Period 12/1/2012 through 12/31/2012

CHECKS IN THE AMOUNT OF \$25,000 OR GREATER

<u>Vendor Name</u>	<u>Check/EFT Number</u>	<u>Payment Date</u>	<u>Invoice Number</u>	<u>Invoice Description</u>	<u>Amount</u>	<u>FYTD</u>
				Remit to: ROSEMEAD, CA	\$59,644.47	\$1,143,324.31
STANDARD INSURANCE CO	215401	12/17/2012	121201a	LIFE & DISABILITY INSURANCE	\$29,274.11	
				Remit to: PORTLAND, OR	\$29,274.11	\$173,092.24
STI, INC. and CAL STRIPE, INC.	215417	12/17/2012	11-901-Ret-5	JOINT CHECK-IRONWOOD AVE IMPROVEMENTS PROJECT RETENTION RELEASE	\$28,262.74	
				Remit to: RIVERSIDE, CA	\$28,262.74	\$28,262.74
STI, INC. and MATICH CORP.	215413	12/17/2012	11-901-Ret-1	JOINT CHECK-IRONWOOD AVE IMPROVEMENTS PROJECT RETENTION RELEASE	\$48,254.58	
				Remit to: RIVERSIDE, CA	\$48,254.58	\$48,254.58
STI, INC. and ROBERTSON'S	215416	12/17/2012	11-901-Ret-4	JOINT CHECK-IRONWOOD AVE IMPROVEMENTS PROJECT RETENTION RELEASE	\$44,545.40	
				Remit to: RIVERSIDE, CA	\$44,545.40	\$44,545.40
STI, INC., TRUCKING MATERIALS	8028	12/03/2012	11-901-Ret	RETENTION RELEASE PAYMENT-IRONWOOD AVE IMPRVMNTS PROJECT	\$88,815.03	
				Remit to: RIVERSIDE, CA	\$88,815.03	\$528,690.97
SULLY- MILLER CONTRACTING CO.	215214	12/03/2012	6-SMC	CONSTRUCTION SERVICES	\$2,211,501.48	
				Remit to: BREA, CA	\$2,211,501.48	\$13,194,441.66
SULLY- MILLER CONTRACTING CO.	215386	12/17/2012	7-SMC	CONSTRUCTION CONTRACT - NASON/CACTUS	\$1,514,913.79	
				Remit to: BREA, CA	\$1,514,913.79	\$13,194,441.66
THINK TOGETHER INC. #201108	215387	12/17/2012	111000-12/13-4	ASES PROGRAM MANAGEMENT SERVICES	\$444,467.51	

-34-



City of Moreno Valley
Payment Register
 For Period 12/1/2012 through 12/31/2012

CHECKS IN THE AMOUNT OF \$25,000 OR GREATER

<u>Vendor Name</u>	<u>Check/EFT Number</u>	<u>Payment Date</u>	<u>Invoice Number</u>	<u>Invoice Description</u>	<u>Amount</u>	<u>FYTD</u>
				Remit to: LOS ANGELES, CA	\$444,467.51	\$1,777,870.00
TRANSTECH ENGINEERS, INC.	215217	12/03/2012	12112939	ENGINEERING SERVICES - NASON/CACTUS	\$56,916.87	
			12106694	ENGINEERING SERVICES - NASON/CACTUS	\$38,318.25	
				Remit to: WALNUT, CA	\$95,235.12	\$307,370.10
U.S. BANK	8175	12/11/2012	W121204	CALCARD PAYMENT FOR CYCLE END 11/27/12	\$172,660.62	
				Remit to: ST. LOUIS, MO	\$172,660.62	\$1,109,140.57
WILLDAN AND ASSOCIATES	215288	12/10/2012	002-12760	PLAN CHECK & INSPECTION SVCS FOR BLDG & SAFETY DEPT.	\$25,697.56	
				Remit to: ANAHEIM, CA	\$25,697.56	\$94,428.98
WRCRCA	215487	12/20/2012	NOV-2012 MSHCP	MSHCP FEES COLLECTED FOR NOVEMBER 2012-COMMERCIAL/INDUSTRIAL	\$359,074.71	
				Remit to: RIVERSIDE, CA	\$359,074.71	\$377,216.46
TOTAL AMOUNTS OF \$25,000 OR GREATER					\$12,162,523.45	

Item No. A.4

135-



City of Moreno Valley
Payment Register
 For Period 12/1/2012 through 12/31/2012

CHECKS UNDER \$25,000

<u>Vendor Name</u>	<u>Check/EFT Number</u>	<u>Payment Date</u>	<u>Invoice Number</u>	<u>Invoice Description</u>	<u>Amount</u>	<u>FYTD</u>
4N6XPRT SYSTEMS	215181	12/03/2012	120760	EXPERT AUTO STATS SOFTWARE-TRAFFIC UNIT	\$492.75	
			Remit to:	LA MESA, CA	\$492.75	\$492.75
A & I REPROGRAPHICS	215349	12/17/2012	CN00010544	REPROGRAPHICS, PLANS AND SPECIFICATIONS	\$1,919.14	
			Remit to:	ONTARIO, CA	\$1,919.14	\$9,972.81
ABILITY COUNTS, INC	215239	12/10/2012	ACI9606	LANDSCAPE MAINT-CFD #1	\$2,065.00	
			Remit to:	CORONA, CA	\$2,065.00	\$12,040.00
ABILITY COUNTS, INC	215449	12/20/2012	ACI9654	LANDSCAPE MAINT-CFD #1	\$1,515.00	
			Remit to:	CORONA, CA	\$1,515.00	\$12,040.00
ACCESS SECURITY CONTROLS INT., INC.	215182	12/03/2012	12-3501	RESET 9412 PANEL TO FACTORY-ERC	\$125.00	
			Remit to:	TEMECULA, CA	\$125.00	\$425.00
ACTION DOOR REPAIR CORP.	215450	12/20/2012	83627	INSPECTED BAY DOOR APPARATUS-FIRE STN 91	\$385.00	
			Remit to:	HUNTINGTON PARK, CA	\$385.00	\$6,494.07
ACTION DOORS	215240	12/10/2012	84047	SVC CALL-DOOR #1-FIRE STN 58	\$879.79	
			84250	REPAIR MOVING WALL-SENIOR CNTR	\$286.24	
			Remit to:	HUNTINGTON PARK, CA	\$1,166.03	\$6,494.07
ACTION DOORS	215350	12/17/2012	84148	REPLACED GATE LOOP DETECTOR-ANIMAL SVCS	\$1,816.84	
			84161	REPAIRED MOVABLE WALL-CRC ALESSANDRO RM	\$991.35	
			84006	INSTALL GATE RADIO RECEIVER-FIRE STN 91	\$321.04	



**City of Moreno Valley
Payment Register
For Period 12/1/2012 through 12/31/2012**

CHECKS UNDER \$25,000

<u>Vendor Name</u>	<u>Check/EFT Number</u>	<u>Payment Date</u>	<u>Invoice Number</u>	<u>Invoice Description</u>	<u>Amount</u>	<u>FYTD</u>
ACTION DOORS	215350	12/17/2012	84003	INSTALL REVERSE GATE EDGE-ANIMAL SVCS	\$549.36	
				Remit to: HUNTINGTON PARK, CA	\$3,678.59	\$6,494.00
ADDICTION MEDICINE CONSULTANTS, INC.	215351	12/17/2012	12M13	D.O.T. DRUG/ALCOHOL TESTING-CY 2013	\$1,595.00	
				Remit to: REDLANDS, CA	\$1,595.00	\$1,595.00
ADLERHORST INTERNATIONAL INC.	215451	12/20/2012	17558	MONTHLY TRAINING-K-9 DUKE-NOV12	\$141.67	
			17559	MONTHLY TRAINING-K-9 OZZIE-NOV12	\$141.67	
			17560	MONTHLY TRAINING-K-9 IVAN-NOV12	\$141.67	
				Remit to: RIVERSIDE, CA	\$425.01	\$425.01
ADMINSURE	215183	12/03/2012	6078	WORKER'S COMP CLAIMS ADMIN	\$2,600.00	
			6123	WORKERS' COMP CLAIMS ADMIN	\$2,600.00	
				Remit to: DIAMOND BAR, CA	\$5,200.00	\$18,200.00
ADVANCED ELECTRIC	215241	12/10/2012	10557	CITY HALL ELECTRICAL REPAIRS-TECH SVCS	\$823.00	
				Remit to: RIVERSIDE, CA	\$823.00	\$16,923.18
ADVANCED ELECTRIC	215452	12/20/2012	10640	ELECTRICAL REPAIRS-CITY HALL	\$506.00	
			10667	ELECTRICAL REPAIRS-TOWNGATE CC FOUNTAIN	\$950.00	
				Remit to: RIVERSIDE, CA	\$1,456.00	\$16,923.18
AEI-CASC ENGINEERING	8044	12/10/2012	0028762	PLAN CHECK SVCS - WQMP	\$1,270.00	
				Remit to: COLTON, CA	\$1,270.00	\$18,301.31
AEROTEK PROFESSIONAL SERVICES	215352	12/17/2012	OP03741294	TEMPORARY PERSONNEL SVCS-CODE	\$334.80	

Item No. A.4

-37-



**City of Moreno Valley
Payment Register
For Period 12/1/2012 through 12/31/2012**

CHECKS UNDER \$25,000

<u>Vendor Name</u>	<u>Check/EFT Number</u>	<u>Payment Date</u>	<u>Invoice Number</u>	<u>Invoice Description</u>	<u>Amount</u>	<u>FYTD</u>
				Remit to: CHICAGO, IL	\$334.80	\$3,906.00
AEROTEK PROFESSIONAL SERVICES	215454	12/20/2012	OP03788643	TEMPORARY PERSONNEL SVCS-SR. ADMIN ASST-TECH SVCS	\$418.50	
			OP03804939(a)	TEMPORARY PERSONNEL SVCS-SR. ADMIN ASST-TECH SVCS	\$558.00	
				Remit to: CHICAGO, IL	\$976.50	\$3,906.00
AIR EXCHANGE, INC.	215184	12/03/2012	30252	PLYMOVENT MAINT/REPAIR-FIRE STN 2	\$95.99	
				Remit to: SAN BRUNO, CA	\$95.99	\$891.59
ALEX SOLANO	215381	12/17/2012	105	AUDIO VISUAL TECH SERVICES FOR EVENT-CONTR# 21373	\$500.00	
				Remit to: SAN BERNARDINO, CA	\$500.00	\$1,000.00
ALFREY PATTERSON	215302	12/10/2012	121201	RETIREE MED BENEFIT DEC '12	\$225.99	
				Remit to: MORENO VALLEY, CA	\$225.99	\$1,129.95
ALLEEN F. DORY	215293	12/10/2012	121201	RETIREE MED BENEFIT DEC '12	\$225.99	
				Remit to: HEMET, CA	\$225.99	\$1,129.95
ALLIANZ LIFE INSURANCE CO	215394	12/17/2012	121215	NON-EXEMPT ANNUITY	\$75.00	
				Remit to: PITTSBURGH, PA	\$75.00	\$450.00
ALPHA AUTOMATION	215353	12/17/2012	4444	DATA SVC-FUEL TANKS	\$71.10	
				Remit to: LOS ANGELES, CA	\$71.10	\$138.46
AMERICAN FORENSIC NURSES	7999	12/03/2012	62351	BLOOD DRAW-POLICE	\$41.08	
				Remit to: PALM SPRINGS, CA	\$41.08	\$31,580.76
AMERICAN FORENSIC NURSES	8137	12/17/2012	62444	BLOOD DRAW-POLICE	\$350.00	

-38-



**City of Moreno Valley
Payment Register
For Period 12/1/2012 through 12/31/2012**

CHECKS UNDER \$25,000

<u>Vendor Name</u>	<u>Check/EFT Number</u>	<u>Payment Date</u>	<u>Invoice Number</u>	<u>Invoice Description</u>	<u>Amount</u>	<u>FYTD</u>
				Remit to: PALM SPRINGS, CA	\$350.00	\$31,580.7
AMERICAN FORENSIC NURSES	8187	12/20/2012	62443	BLOOD DRAW-POLICE	\$1,939.28	
			62511	BLOOD DRAW SERVICE	\$2,579.40	
				Remit to: PALM SPRINGS, CA	\$4,518.68	\$31,580.7
AMERICAN TOWERS	8045	12/10/2012	1370176	TOWER SPACE LEASE-TECH SVCS	\$2,783.48	
				Remit to: CHARLOTTE, NC	\$2,783.48	\$16,486.76
AMTECH ELEVATOR SERVICES	215185	12/03/2012	DVB05044C12	ELEVATOR MAINT/REPAIR-CITY HALL	\$121.92	
			DVB65909C12	ELEVATOR MAINT/REPAIR-EOC	\$100.00	
				Remit to: PASADENA, CA	\$221.92	\$1,863.10
ANA M. CANNON	8075	12/10/2012	121201	RETIREE MED BENEFIT DEC '12	\$318.73	
				Remit to: HASLET, TX	\$318.73	\$1,593.65
ANDREA SORRELL	215274	12/10/2012	0001-000001	MURAL DESIGN-50/50 UPFRONT FEE	\$6,832.50	
				Remit to: RIVERSIDE, CA	\$6,832.50	\$7,632.50
ANNE EGGERSTEN	215294	12/10/2012	121201	RETIREE MED BENEFIT DEC '12	\$320.43	
				Remit to: RANCHO MIRAGE, CA	\$320.43	\$1,602.15
ARIEL MUNOZ	215492	12/20/2012	10/3-11/20/12	MILEAGE REIMBURSEMENT	\$106.01	
				Remit to: MORENO VALLEY, CA	\$106.01	\$311.36
ARROWHEAD DIRECT	8000	12/03/2012	02K0032414377	WATER PURIFY RNTL UNIT-PSB	\$27.85	
				Remit to: LOUISVILLE, KY	\$27.85	\$3,070.97
ARROWHEAD DIRECT	8046	12/10/2012	02K0032389744	WATER PURIFY RNTL UNIT-FIRE STN 99	\$24.77	

Item No. A.4

-39-



City of Moreno Valley
Payment Register
 For Period 12/1/2012 through 12/31/2012

CHECKS UNDER \$25,000

<u>Vendor Name</u>	<u>Check/EFT Number</u>	<u>Payment Date</u>	<u>Invoice Number</u>	<u>Invoice Description</u>	<u>Amount</u>	<u>FYTD</u>
ARROWHEAD DIRECT	8046	12/10/2012	02K0029115227	WATER PURIFY RNTL UNIT-SDA ANNEX	\$26.93	
			02K0029115201	WATER PURIFY RNTL UNIT-SENIOR CNTR	\$24.77	
			02K0029115300	WATER PURIFY RNTL UNIT-FACILITIES ANNEX	\$26.93	
			02K0029115359	WATER PURIFY RNTL UNIT-CRC	\$26.93	
			02K0029115177	WATER PURIFY RNTL UNIT-ANIMAL SVCS	\$59.25	
			02K0029115243	WATER PURIFY RNTL UNIT-TECH SVCS ANNEX	\$26.93	
				Remit to: LOUISVILLE, KY	\$216.51	\$3,070.97
ASSISTANCE LEAGUE OF RIVERSIDE	215187	12/03/2012	102512	CDBG GRANT-OPERATION SCHOOL BELL	\$10,000.00	
				Remit to: RIVERSIDE, CA	\$10,000.00	\$10,000.00
AT&T	215190	12/03/2012	3698157	LANDLINE PHONE SVC FOR GTF SATELITE OFFICE	\$184.03	
				Remit to: CAROL STREAM, IL	\$184.03	\$735.42
AT&T MCI	215189	12/03/2012	3861091	LANDLINE PHONE SVC FOR GTF SATELITE OFFICE	\$184.03	
			3617131	LANDLINE PHONE SVC FOR GTF SATELITE OFFICE	\$184.03	
				Remit to: WEST SACRAMENTO, CA	\$368.06	\$368.06
AT&T MOBILITY	215188	12/03/2012	872455379X110612	WIRELESS SVC-POLICE	\$91.92	
				Remit to: CAROL STREAM, IL	\$91.92	\$459.63
ATHALYE CONSULTING ENGINEERING SERVICES	215456	12/20/2012	MV-07	CONSULTING SERVICES	\$2,725.37	
			MV-06	CONSULTING SERVICES	\$11,881.44	

40-



**City of Moreno Valley
Payment Register
For Period 12/1/2012 through 12/31/2012**

CHECKS UNDER \$25,000

<u>Vendor Name</u>	<u>Check/EFT Number</u>	<u>Payment Date</u>	<u>Invoice Number</u>	<u>Invoice Description</u>	<u>Amount</u>	<u>FYTD</u>
				Remit to: LAKE FOREST, CA	\$14,606.81	\$65,633.7
B&B NURSERYTOWN	8135	12/10/2012	13750	PLANT MATERIALS PER QUOTE MV060807	\$2,113.45	
				Remit to: BLOOMINGTON, CA	\$2,113.45	\$4,226.9
B&B NURSERYTOWN	215340	12/10/2012	13750	PLANT MATERIALS PER QUOTE MV060807	\$2,113.45	
				Remit to: BLOOMINGTON, CA	\$2,113.45	\$4,226.90
BAKER & TAYLOR	215242	12/10/2012	0002321307	MISC E-BOOK DISCOUNT CREDIT-LIBRARY	(\$84.98)	
			4010329424	MISC E-BOOK-LIBRARY	\$14.00	
			4010231907	MISC E-BOOKS-LIBRARY	\$98.91	
			4010310311	MISC E-BOOKS-LIBRARY	\$664.52	
			4010310306	MISC E-BOOK-LIBRARY	\$19.99	
			4010231909	MISC E-BOOKS-LIBRARY	\$150.88	
			4010231908	MISC E-BOOKS-LIBRARY	\$817.49	
				Remit to: ATLANTA, GA	\$1,680.81	\$4,984.96
BEMUS LANDSCAPE, INC.	8001	12/03/2012	236755	LANDSCAPE MAINT-FIRE STNS	\$2,835.00	
			236743	LANDSCAPE MAINT-ANNEX 1	\$221.00	
			236742	LANDSCAPE MAINT-VETERANS MEMORIAL	\$225.00	
			236754	LANDSCAPE MAINT-CITY HALL	\$893.30	
				Remit to: SAN CLEMENTE, CA	\$4,174.30	\$105,560.54
BEMUS LANDSCAPE, INC.	8047	12/10/2012	236747	LANDSCAPE MAINT-LIBRARY	\$468.00	
			236753	LANDSCAPE MAINT-ANIMAL SVCS	\$468.00	
			236752	LANDSCAPE MAINT-PSB	\$1,077.83	

Item No. A.4

-41-



City of Moreno Valley
Payment Register
 For Period 12/1/2012 through 12/31/2012

CHECKS UNDER \$25,000

<u>Vendor Name</u>	<u>Check/EFT Number</u>	<u>Payment Date</u>	<u>Invoice Number</u>	<u>Invoice Description</u>	<u>Amount</u>	<u>FYTD</u>
BEMUS LANDSCAPE, INC.	8047	12/10/2012	236751	LANDSCAPE MAINT-MVU SUBSTN	\$567.00	
			236750	LANDSCAPE MAINT-TOWNGATE BIKE AQDCT	\$735.00	
			236749	LANDSCAPE MAINT-TOWNGATE CNTR	\$180.00	
			236748	LANDSCAPE MAINT-MVU	\$432.00	
			236746	LANDSCAPE MAINT-CRC	\$1,710.00	
			236745	LANDSCAPE MAINT-FORMER STARS BLDG	\$260.00	
			236744	LANDSCAPE MAINT-CITY YARD	\$225.00	
			236740	LANDSCAPE MAINT-S AQDCT A	\$765.50	
			236739	LANDSCAPE MAINT-INDIAN/FILAREE/FAY BIKE AQDCT	\$360.00	
			236738	LANDSCAPE MAINT-BAY/JFK AQDCT	\$1,710.00	
			236736	LANDSCAPE MAINT-SCE/OLD LAKE DR	\$1,575.00	
			236735	LANDSCAPE MAINT-SENIOR CNTR	\$236.00	
			236734	LANDSCAPE MAINT-PAN AM/AQDCT	\$540.00	
			236733	LANDSCAPE MAINT-N AQDCT	\$473.00	
			236732	LANDSCAPE MAINT-S AQDCT B	\$662.00	
236737	LANDSCAPE MAINT-PATRIOT PARK	\$360.00				
				Remit to: SAN CLEMENTE, CA	\$12,804.33	\$105,560.54
BEMUS LANDSCAPE, INC.	8188	12/20/2012	237682	TRENCH WORK FOR FIBER OPTIC CABLE-CONDUIT	\$8,033.00	
				Remit to: SAN CLEMENTE, CA	\$8,033.00	\$105,560.54
BENESYST	8002	12/03/2012	1112285	FSA ADMIN COSTS-COBRA	\$205.00	

-42-



**City of Moreno Valley
Payment Register
For Period 12/1/2012 through 12/31/2012**

CHECKS UNDER \$25,000

<u>Vendor Name</u>	<u>Check/EFT Number</u>	<u>Payment Date</u>	<u>Invoice Number</u>	<u>Invoice Description</u>	<u>Amount</u>	<u>FYTD</u>
				Remit to: MINNEAPOLIS, MN	\$205.00	\$2,267.8
BENESYST, INC.	8003	12/03/2012	1112144	FSA ADMIN COSTS	\$201.90	
				Remit to: MINNEAPOLIS, MN	\$201.90	\$201.9
BENJAMIN LANGENDORF	8097	12/10/2012	121201	RETIREE MED BENEFIT NOV '12, PD DEC '12	\$318.73	
				Remit to: PERRIS, CA	\$318.73	\$1,529.51
BEST, BEST & KRIEGER, LLP	8048	12/10/2012	689661	LEGAL SVCS	\$336.00	
				Remit to: RIVERSIDE, CA	\$336.00	\$5,646.50
BEST, BEST & KRIEGER, LLP	8138	12/17/2012	691752	LEGAL SVCS	\$70.00	
				Remit to: RIVERSIDE, CA	\$70.00	\$5,646.50
BIO-TOX LABORATORIES	215191	12/03/2012	25968	BLOOD DRAW TOXICOLOGY ANALYSIS-POLICE	\$8,348.60	
			25967	BLOOD DRAW TOXICOLOGY ANALYSIS-POLICE	\$3,816.80	
				Remit to: RIVERSIDE, CA	\$12,165.40	\$65,289.50
BLANCA DURAN	215404	12/17/2012	DEC-2012	INSTRUCTOR SVCS-FOLKLORIC DANCE CLASS	\$126.00	
				Remit to: MORENO VALLEY, CA	\$126.00	\$1,092.00
BOX SPRINGS MUTUAL WATER COMPANY	215243	12/10/2012	11262012	WATER USAGE ACCOUNT 721-1 ZONE E-1	\$86.30	
				Remit to: MORENO VALLEY, CA	\$86.30	\$179.23
BRAUN BLAISING MCLAUGHLIN	215244	12/10/2012	14478	LEGAL SVCS-MVU	\$3,661.99	
				Remit to: SACRAMENTO, CA	\$3,661.99	\$47,129.36
BRAUN BLAISING MCLAUGHLIN	215354	12/17/2012	14403	LEGAL SVCS	\$1,199.50	

Item No. A.4

-43-



City of Moreno Valley
Payment Register
 For Period 12/1/2012 through 12/31/2012

CHECKS UNDER \$25,000

<u>Vendor Name</u>	<u>Check/EFT Number</u>	<u>Payment Date</u>	<u>Invoice Number</u>	<u>Invoice Description</u>	<u>Amount</u>	<u>FYTD</u>
BRAUN BLAISING MCLAUGHLIN	215354	12/17/2012	14462	LEGAL SVCS	\$6,712.53	
			14448	LEGAL SVCS	\$8,720.00	
			14378	LEGAL SVCS	\$2,034.50	
				Remit to: SACRAMENTO, CA	\$18,666.53	\$47,129.36
BRODART CO.	8004	12/03/2012	P544	TIPS ANNUAL RENEWAL-LIBRARY	\$1,200.00	
				Remit to: WILLIAMSPORT, PA	\$1,200.00	\$6,361.86
BURKE, WILLIAMS & SORENSEN, LLP.	8005	12/03/2012	160421	LEGAL SVCS-FILE#05696-0023	\$141.22	
				Remit to: LOS ANGELES, CA	\$141.22	\$1,340.61
BURKE, WILLIAMS & SORENSEN, LLP.	215192	12/03/2012	160418	LEGAL SVCS-FILE#05696-0004	\$228.00	
				Remit to: LOS ANGELES, CA	\$228.00	\$54,000.47
CALIFORNIA DEPT OF EDUCATION	215246	12/10/2012	C-049566	RECOVER XCESS-CHILD DVLPMT 2010/11 SHARE	\$7,476.00	
			C-049588	RECOVER XCESS-CHILD DVLPMT 2010/11 SHARE	\$1,302.00	
				Remit to: SACRAMENTO, CA	\$8,778.00	\$8,778.00
CALIFORNIA FACILITY SPECIALTIES	215193	12/03/2012	628	GYM BLEACHERS SVC'D-CRC	\$775.00	
				Remit to: SAN DIMAS, CA	\$775.00	\$775.00
CALIFORNIA SHOPPING CART RETRIEVAL CORP	8049	12/10/2012	140930	SHOPPING CART RETRIEVAL SVCS-OCT12	\$1,800.00	
				Remit to: BURBANK, CA	\$1,800.00	\$9,000.00
CALVARY CHAPEL OF MORENO VALLEY	215355	12/17/2012	090612	REIMBURSEMENT FOR APPRAISAL SERVICES - SR-60/MORENO PH2	\$4,000.00	

-44-



City of Moreno Valley
Payment Register
 For Period 12/1/2012 through 12/31/2012

CHECKS UNDER \$25,000

<u>Vendor Name</u>	<u>Check/EFT Number</u>	<u>Payment Date</u>	<u>Invoice Number</u>	<u>Invoice Description</u>	<u>Amount</u>	<u>FYTD</u>
				Remit to: MORENO VALLEY, CA	\$4,000.00	\$4,000.00
CANYON SPRINGS HIGH SCHOOL	215488	12/20/2012	DONATION	DRAMA CLUB-TRANSPORTATION TO RCC ON 2/14/13	\$275.00	
				Remit to: MORENO VALLEY, CA	\$275.00	\$275.00
CAROLYN S. LEWIS	8098	12/10/2012	121201	RETIREE MED BENEFIT DEC '12	\$318.73	
				Remit to: BEAUMONT, CA	\$318.73	\$1,593.65
CAVENAUGH & ASSOCIATES	8006	12/03/2012	JAN. 14-18, 2013	D.U.I. SEMINAR REGISTR-4 OFFICERS: MARKER, MURPHY, SAYLES, YOUNG	\$2,204.00	
				Remit to: MOUNT SHASTA, CA	\$2,204.00	\$2,204.00
CEMEX, INC.	215247	12/10/2012	9425028947	PORTLAND CEMENT-MAIN/OP'S	\$371.21	
				Remit to: PASADENA, CA	\$371.21	\$6,763.45
CEMEX, INC.	215356	12/17/2012	9425108952	PORTLAND CEMENT-MAIN/OP'S	\$321.88	
			9425072929	PORTLAND CEMENT-MAIN/OP'S	\$346.53	
			9425100269	PORTLAND CEMENT-MAIN/OP'S	\$371.23	
				Remit to: PASADENA, CA	\$1,039.64	\$6,763.45
CENTRAL OCCUPATIONAL MEDICINE PROVIDERS	215194	12/03/2012	04-0308203	PRE-EMPLOYMENT PHYSICAL/DRUG TEST	\$45.00	
			04-0308369	PRE-EMPLOYMENT PHYSICAL/DRUG TEST	\$18.00	
			04-0308370	PRE-EMPLOYMENT PHYSICAL/DRUG TEST	\$25.00	
			04-0308450	PRE-EMPLOYMENT PHYSICAL/DRUG TEST	\$32.50	
			05-0326561	PRE-EMPLOYMENT PHYSICAL/DRUG TEST	\$45.00	
			05-0326556	PRE-EMPLOYMENT PHYSICAL/DRUG TEST	\$35.00	

Item No. A.4

45-



City of Moreno Valley
Payment Register
 For Period 12/1/2012 through 12/31/2012

CHECKS UNDER \$25,000

<u>Vendor Name</u>	<u>Check/EFT Number</u>	<u>Payment Date</u>	<u>Invoice Number</u>	<u>Invoice Description</u>	<u>Amount</u>	<u>FYTD</u>
CENTRAL OCCUPATIONAL MEDICINE PROVIDERS	215194	12/03/2012	04-0308371	PRE-EMPLOYMENT PHYSICAL/DRUG TEST	\$32.50	
			04-0308437	PRE-EMPLOYMENT PHYSICAL/DRUG TEST	\$25.00	
			04-0308392	PRE-EMPLOYMENT PHYSICAL/DRUG TEST	\$45.00	
			04-0307776	PRE-EMPLOYMENT PHYSICAL/DRUG TEST	\$45.00	
Remit to:				RIVERSIDE, CA	\$348.00	\$4,195.50
CENTRAL OCCUPATIONAL MEDICINE PROVIDERS	215248	12/10/2012	04-0308623	PRE-EMPLOYMENT PHYSICAL/DRUG TEST	\$45.00	
			04-0308513	PRE-EMPLOYMENT PHYSICAL/DRUG TEST	\$25.00	
			04-0308525	PRE-EMPLOYMENT PHYSICAL/DRUG TEST	\$45.00	
			04-0308524	PRE-EMPLOYMENT PHYSICAL/DRUG TEST	\$45.00	
Remit to:				RIVERSIDE, CA	\$160.00	\$4,195.50
CENTRAL OCCUPATIONAL MEDICINE PROVIDERS	215357	12/17/2012	04-0308808	PRE-EMPLOYMENT PHYSICAL/DRUG TEST	\$25.00	
			04-0308921	PRE-EMPLOYMENT PHYSICAL/DRUG TEST	\$45.00	
Remit to:				RIVERSIDE, CA	\$70.00	\$4,195.50
CERTIFIED CREDIT REPORTING, INC	215195	12/03/2012	106734	CREDIT REPORT SVCS-NEIGHBRHD PRESVTN	\$77.76	
Remit to:				ONTARIO, CA	\$77.76	\$96.72
CHANDLER ASSET MANAGEMENT, INC	215358	12/17/2012	12062	INVESTMENT MANAGEMENT SVCS-NOV12	\$7,858.00	
Remit to:				SAN DIEGO, CA	\$7,858.00	\$16,318.00
CHARLES E. KOLB	8092	12/10/2012	121201	RETIREE MED BENEFIT DEC '12	\$318.73	
Remit to:				MORENO VALLEY, CA	\$318.73	\$1,593.65

-46-



**City of Moreno Valley
Payment Register
For Period 12/1/2012 through 12/31/2012**

CHECKS UNDER \$25,000

<u>Vendor Name</u>	<u>Check/EFT Number</u>	<u>Payment Date</u>	<u>Invoice Number</u>	<u>Invoice Description</u>	<u>Amount</u>	<u>FYTD</u>
CHARLES HATFIELD	8089	12/10/2012	121201	RETIREE MED BENEFIT DEC '12	\$318.73	
				Remit to: LAS VEGAS, NV	\$318.73	\$1,593.6
CHARLES LOGAN	8099	12/10/2012	121201	RETIREE MED BENEFIT DEC '12	\$318.73	
				Remit to: LAS VEGAS, NV	\$318.73	\$1,593.6
CHIZURU CHANCY	215403	12/17/2012	NOV-2012	INSTRUCTOR SVCS-HAWAIIAN DANCE CLASSES	\$85.20	
			DEC-2012	INSTRUCTOR SVCS-HAWAIIAN DANCE CLASSES	\$147.00	
				Remit to: MORENO VALLEY, CA	\$232.20	\$941.40
CHRISTINA LARA	215313	12/10/2012	121129	SPOUSAL SUPPORT & ARREARS	\$669.23	
				Remit to: ENCINITAS, CA	\$669.23	\$8,030.76
CHRISTINA LARA	215398	12/17/2012	121215	SPOUSAL SUPPORT & ARREARS	\$669.23	
				Remit to: ENCINITAS, CA	\$669.23	\$8,030.76
CHRISTOPHER WIBERG	215310	12/10/2012	121201	RETIREE MED BENEFIT DEC '12	\$318.73	
				Remit to: ANAHEIM, CA	\$318.73	\$1,593.65
CINTAS CORPORATION	8007	12/03/2012	150737962	UNIFORM RNTL SVC-PURCHASING	\$4.13	
			150728918	UNIFORM RNTL SVC-TRAFFIC SIGNAL	\$13.50	
			150742475	UNIFORM RNTL SVC-PURCHASING	\$4.13	
			150737973	UNIFORM RNTL SVC-FACILITIES	\$18.13	
			150724438	UNIFORM RNTL SVC-TRAFFIC SIGNAL	\$13.50	
			150724439	UNIFORM RNTL SVC-SIGNING/STRIPING	\$17.05	
			150710973	UNIFORM RNTL SVC-PURCHASING	\$4.13	

Item No. A.4

47-



City of Moreno Valley
Payment Register
 For Period 12/1/2012 through 12/31/2012

CHECKS UNDER \$25,000

<u>Vendor Name</u>	<u>Check/EFT Number</u>	<u>Payment Date</u>	<u>Invoice Number</u>	<u>Invoice Description</u>	<u>Amount</u>	<u>FYTD</u>
CINTAS CORPORATION	8007	12/03/2012	150715483	UNIFORM RNTL SVC-PURCHASING	\$4.13	
			150719945	UNIFORM RNTL SVC-PURCHASING	\$4.13	
			150733474	UNIFORM RNTL SVC-FACILITIES	\$18.13	
			150728919	UNIFORM RNTL SVC-SIGNING/STRIPING	\$17.05	
			150733463	UNIFORM RNTL SVC-PURCHASING	\$4.13	
			150737963	UNIFORM RNTL SVC-TRAFFIC SIGNAL	\$13.50	
			150737964	UNIFORM RNTL SVC-SIGNING/STRIPING	\$17.05	
			150728917	UNIFORM RNTL SVC-PURCHASING	\$4.13	
			150724437	UNIFORM RNTL SVC-PURCHASING	\$4.13	
			150742486	UNIFORM RNTL SVC-FACILITIES	\$18.13	
Remit to:				ONTARIO, CA	\$179.08	\$8,042.13
CINTAS CORPORATION	8050	12/10/2012	150742481	UNIFORM RNTL SVC-CFD #1	\$13.25	
			150737968	UNIFORM RNTL SVC-CFD #1	\$13.25	
			150742477	UNIFORM RNTL SVC-SIGNING/STRIPING	\$17.05	
			150737961	UNIFORM RNTL SVC-PARK MAINT	\$57.96	
			150742487	UNIFORM RNTL SVC-GOLF COURSE	\$2.93	
			150742476	UNIFORM RNTL SVC-TRAFFIC SIGNAL	\$13.50	
			150737974	UNIFORM RNTL SVC-GOLF COURSE	\$2.93	
			150742474	UNIFORM RNTL SVC-PARK MAINT	\$57.96	
Remit to:				ONTARIO, CA	\$178.83	\$8,042.13
CINTAS CORPORATION	8139	12/17/2012	150747018	UNIFORM RNTL SVC-GOLF COURSE	\$2.93	
			150747005	UNIFORM RNTL SVC-PARK MAINT	\$57.96	

-48-



**City of Moreno Valley
Payment Register
For Period 12/1/2012 through 12/31/2012**

CHECKS UNDER \$25,000

<u>Vendor Name</u>	<u>Check/EFT Number</u>	<u>Payment Date</u>	<u>Invoice Number</u>	<u>Invoice Description</u>	<u>Amount</u>	<u>FYTD</u>
CINTAS CORPORATION	8139	12/17/2012	150747008	UNIFORM RNTL SVC-SIGNING/STRIPING	\$17.05	
			150747007	UNIFORM RNTL SVC-TRAFFIC SIGNAL	\$13.50	
			150747017	UNIFORM RNTL SVC-FACILITIES	\$18.13	
			150737965	UNIFORM RNTL SVC-GRAFFITI RMVL	\$15.81	
			150747012	UNIFORM RNTL SVC-CFD #1	\$13.25	
			150737972	UNIFORM RNTL SVC-CONCRETE MAINT	\$16.23	
			150737966	UNIFORM RNTL SVC-VEHICLE MAINT	\$41.53	
			150737969	UNIFORM RNTL SVC-ST SWEEPING	\$9.33	
			150737970	UNIFORM RNTL SVC-DRAIN MAINT	\$5.69	
			150737967	UNIFORM RNTL SVC-TREE MAINT	\$15.81	
			150737971	UNIFORM RNTL SVC-ST MAINT	\$104.50	
			150742478	UNIFORM RNTL SVC-GRAFFITI RMVL	\$15.81	
			150742479	UNIFORM RNTL SVC-VEHICLE MAINT	\$41.53	
			150742480	UNIFORM RNTL SVC-TREE MAINT	\$15.81	
			150742482	UNIFORM RNTL SVC-ST SWEEPING	\$9.33	
			150742483	UNIFORM RNTL SVC-DRAIN MAINT	\$5.69	
			150742484	UNIFORM RNTL SVC-ST MAINT	\$104.50	
			150742485	UNIFORM RNTL SVC-CONCRETE MAINT	\$16.23	
				Remit to: ONTARIO, CA	\$540.62	\$8,042.13
CITY OF MORENO VALLEY VEBA TRUST	8133	12/10/2012	121129	EXEMPT VEBA	\$2,045.00	
				Remit to: MORENO VALLEY, CA	\$2,045.00	\$52,214.31
CITY OF MORENO VALLEY VEBA TRUST	8164	12/17/2012	121215	EXEMPT VEBA	\$6,882.50	

Item No. A.4

-49-



**City of Moreno Valley
Payment Register
For Period 12/1/2012 through 12/31/2012**

CHECKS UNDER \$25,000

<u>Vendor Name</u>	<u>Check/EFT Number</u>	<u>Payment Date</u>	<u>Invoice Number</u>	<u>Invoice Description</u>	<u>Amount</u>	<u>FYTD</u>
				Remit to: MORENO VALLEY, CA	\$6,882.50	\$52,214.31
CLARENCE VINCENT	215309	12/10/2012	121201	RETIREE MED 1ST PYCK JAN'04 & NOV'12, PD DEC '12	\$311.73	
				Remit to: MORENO VALLEY, CA	\$311.73	\$16,807.77
CLAUDIA SALMAN	215409	12/17/2012	NOV-2012	INSTRUCTOR SVCS-LATIN ZUMBA CLASS	\$90.00	
			DEC-2012	INSTRUCTOR SVCS-LATIN ZUMBA CLASS	\$54.00	
				Remit to: MORENO VALLEY, CA	\$144.00	\$498.00
CLIFFORD STEWART	8126	12/10/2012	121201	RETIREE MED BENEFIT DEC '12	\$271.44	
				Remit to: GLENDALE, AZ	\$271.44	\$1,357.20
COLGAN CONSULTING CORPORATION	215196	12/03/2012	9	DIF STUDY UPDATE-SEPT12	\$5,130.00	
				Remit to: SACRAMENTO, CA	\$5,130.00	\$9,787.50
COLONIAL SUPPLEMENTAL INSURANCE	215224	12/03/2012	7133069-1201615	SUPPLEMENTAL INSURANCE	\$7,148.55	
				Remit to: COLUMBIA, SC	\$7,148.55	\$35,839.75
COMMUNITY ASSIST PROG	8051	12/10/2012	JUL-2012	CAP FOOD PROGRAM-CDBG	\$2,309.28	
			AUG-2012	CAP FOOD PROGRAM-CDBG	\$2,779.93	
				Remit to: MORENO VALLEY, CA	\$5,089.21	\$8,874.23
COMMUNITY CONNECT	215249	12/10/2012	12-13 1	211 CALL CENTER INFO/REFERRAL	\$346.40	
			AUG-2012	211 CALL CENTER INFO/REFERRAL	\$568.97	
			OCT-2012	211 CALL CENTER INFO/REFERRAL	\$524.95	
			SEP-2012	211 CALL CENTER INFO/REFERRAL	\$556.08	
				Remit to: RIVERSIDE, CA	\$1,996.40	\$2,097.14

-5-



**City of Moreno Valley
Payment Register
For Period 12/1/2012 through 12/31/2012**

CHECKS UNDER \$25,000

<u>Vendor Name</u>	<u>Check/EFT Number</u>	<u>Payment Date</u>	<u>Invoice Number</u>	<u>Invoice Description</u>	<u>Amount</u>	<u>FYTD</u>
COMMUNITY HEALTH CHARITIES	215311	12/10/2012	121129	CHC CONTRIBUTIONS	\$142.00	
			Remit to:	ANAHEIM, CA	\$142.00	\$1,704.00
COMMUNITY HEALTH CHARITIES	215395	12/17/2012	121215	CHC CONTRIBUTIONS	\$142.00	
			Remit to:	ANAHEIM, CA	\$142.00	\$1,704.00
CORNERSTONE RECORDS MANAGEMENT, LLC	215455	12/20/2012	0196195	RECORDS OFF-SITE STORAGE	\$1,220.24	
			Remit to:	KING OF PRUSSIA, PA	\$1,220.24	\$1,220.24
COSTCO	215197	12/03/2012	19116	SNACK SUPPLIES FOR "A CHILD'S PLACE"	\$336.57	
			Remit to:	MORENO VALLEY, CA	\$336.57	\$7,205.19
COSTCO	215359	12/17/2012	19159	SNACK SUPPLIES FOR SKATE PARK	\$161.35	
			Remit to:	MORENO VALLEY, CA	\$161.35	\$7,205.19
COUNTRY SQUIRE ESTATES	215457	12/20/2012	JULY 2012	REFUND-UUT FOR EXEMPT RESIDENTS	\$66.08	
			JUNE 2012	REFUND-UUT FOR EXEMPT RESIDENTS	\$60.49	
			OCTOBER 2012	REFUND-UUT FOR EXEMPT RESIDENTS	\$68.40	
			AUGUST 2012	REFUND-UUT FOR EXEMPT RESIDENTS	\$84.67	
			SEPTEMBER 2012	REFUND-UUT FOR EXEMPT RESIDENTS	\$90.31	
			Remit to:	ONTARIO, CA	\$369.95	\$566.41
COUNTY OF RIVERSIDE	215489	12/20/2012	PU0000002660	JANITORIAL ITEMS FOR STATION EXPLORERS	\$1,222.07	
			Remit to:	MORENO VALLEY, CA	\$1,222.07	\$4,274.83
COUNTY OF RIVERSIDE, AUDITOR-CONTROLLER	215342	12/11/2012	AUG-12	TRANSMITTAL OF AB544-PARKING CONTROL FEES	\$22,202.54	

Item No. A.4

-51-



**City of Moreno Valley
Payment Register
For Period 12/1/2012 through 12/31/2012**

CHECKS UNDER \$25,000

<u>Vendor Name</u>	<u>Check/EFT Number</u>	<u>Payment Date</u>	<u>Invoice Number</u>	<u>Invoice Description</u>	<u>Amount</u>	<u>FYTD</u>
				Remit to: RIVERSIDE, CA	\$22,202.54	\$79,664.46
CRAIG S. NEUSTAEDTER	215300	12/10/2012	121201	RETIREE MED BENEFIT DEC '12	\$318.73	
				Remit to: IRVINE, CA	\$318.73	\$1,593.65
CRIME SCENE STERI-CLEAN, LLC	215251	12/10/2012	31618	BIOHAZARD CLEANING SVCS FOR PD-11/20/12	\$750.00	
				Remit to: RANCHO CUCAMONGA, CA	\$750.00	\$6,750.00
CYNTHIA GORDON	8083	12/10/2012	121201	RETIREE MED BENEFIT JAN-OCT '12, PD DEC '12	\$2,809.84	
				Remit to: MURRIETA, CA	\$2,809.84	\$2,809.84
CYNTHIA L. OWENS	215494	12/20/2012	COSTCO 12/17/12	REIMBURSEMENT FOR REFRESHMENTS FOR FIRE DEPT. TRAINING SESSION	\$117.15	
				Remit to: RIVERSIDE, CA	\$117.15	\$117.15
D & D SERVICES	215199	12/03/2012	57773	DECEASED ANIMAL REMOVAL-ANIMAL SVCS	\$745.00	
				Remit to: VALENCIA, CA	\$745.00	\$4,470.00
D & D SERVICES	215459	12/20/2012	54737	DECEASED ANIMAL REMOVAL-ANIMAL SVCS	\$745.00	
				Remit to: VALENCIA, CA	\$745.00	\$4,470.00
DAN GOZDECKI	8144	12/17/2012	DEC-2012/YOUTH	INSTRUCTOR SVCS-KUNG FU CLASS	\$378.00	
			DEC-2012/ADULT	INSTRUCTOR SVCS-KUNG FU CLASS	\$162.00	
				Remit to: MORENO VALLEY, CA	\$540.00	\$2,981.40
DANIEL MEEKS	8147	12/17/2012	111812	SPORTS OFFICIATING SERVICES	\$60.00	
			120212	SPORTS OFFICIATING SERVICES	\$40.00	
				Remit to: PERRIS, CA	\$100.00	\$840.00



City of Moreno Valley
Payment Register
 For Period 12/1/2012 through 12/31/2012

CHECKS UNDER \$25,000

<u>Vendor Name</u>	<u>Check/EFT Number</u>	<u>Payment Date</u>	<u>Invoice Number</u>	<u>Invoice Description</u>	<u>Amount</u>	<u>FYTD</u>
DARCY L. RAY-RAMIREZ	215304	12/10/2012	121201	RETIREE MED BENEFIT DEC '12	\$318.73	
			Remit to:	RIVERSIDE, CA	\$318.73	\$1,593.6
DATA TICKET INC.	8009	12/03/2012	42421TP	ADMIN CITATION PROCESSING-B&S	\$54.00	
			42813	ADMIN CITATION PROCESSING-B&S	\$329.40	
			Remit to:	NEWPORT BEACH, CA	\$383.40	\$24,386.93
DATA TICKET INC.	8140	12/17/2012	43387	DATA CITATION PROCESSING-SEPT12	\$11,014.49	
			44310MS	MAINTENANCE/SUPPORT-NOV12	\$94.50	
			43840	DATA CITATION PROCESSING-OCT12	\$11,501.52	
			Remit to:	NEWPORT BEACH, CA	\$22,610.51	\$24,386.93
DATA TICKET INC.	8189	12/20/2012	44183TPC	ADMIN CITATION PROCESSING-3RD PARTY COLLECTION-NOV12-A/S	\$58.32	
			44183	ADMIN CITATION PROCESSING-NOV12-A/S	\$1,334.70	
			Remit to:	NEWPORT BEACH, CA	\$1,393.02	\$24,386.93
DATA TICKET, INC.	8010	12/03/2012	43841	MAINTENANCE/SUPPORT-OCT12	\$94.50	
			43304	ADMIN CITATION PROCESSING-BLDG/SAFETY	\$189.00	
			43304TPC	THIRD PARTY COLLECTIONS-BLDG/SAFETY	\$58.32	
			42421	ADMIN CITATION PROCESSING-B&S	\$108.00	
			43729	B & S ADMIN CITE PROCESSING	\$1,007.82	
			Remit to:	NEWPORT BEACH, CA	\$1,457.64	\$55,715.28
DATA TICKET, INC.	8136	12/11/2012	42924	DATA CITATION PROCESSING-AUG12	\$11,889.73	
			Remit to:	NEWPORT BEACH, CA	\$11,889.73	\$55,715.28

Item No. A.4

-53-



City of Moreno Valley
Payment Register
 For Period 12/1/2012 through 12/31/2012

CHECKS UNDER \$25,000

<u>Vendor Name</u>	<u>Check/EFT Number</u>	<u>Payment Date</u>	<u>Invoice Number</u>	<u>Invoice Description</u>	<u>Amount</u>	<u>FYTD</u>
DATA TICKET, INC.	8190	12/20/2012	44186	ADMIN CITATION PROCESSING-NOV12-PD	\$1,959.33	
			Remit to:	NEWPORT BEACH, CA	\$1,959.33	\$55,715.28
DATAQUICK	215362	12/17/2012	B1-2100216	ONLINE SOFTWARE SUBSCRIPTION-POP UNIT	\$130.50	
			Remit to:	LOS ANGELES, CA	\$130.50	\$261.00
DAVID MUSSER	215493	12/20/2012	DEC-2012	INSTRUCTOR SVCS-WATERCOLOR TECHNIQUE CLASS	\$378.00	
			Remit to:	MENIFEE, CA	\$378.00	\$2,856.00
DAVID T. ROSS	8118	12/10/2012	121201	RETIREE MED BENEFIT DEC '12	\$318.73	
			Remit to:	MORENO VALLEY, CA	\$318.73	\$1,593.65
DEBINAIRE COMPANY	215363	12/17/2012	704537	BOILER MAINT-EOC	\$140.00	
			Remit to:	CORONA, CA	\$140.00	\$1,174.98
DELTA DENTAL OF CALIFORNIA	8033	12/03/2012	BE000439019	EMPLOYEE DENTAL INSURANCE	\$10,286.65	
			Remit to:	SAN FRANCISCO, CA	\$10,286.65	\$60,333.83
DELTACARE USA	215364	12/17/2012	5050298	EMPLOYEE DENTAL INSURANCE	\$5,818.37	
			Remit to:	LOS ANGELES, CA	\$5,818.37	\$34,644.94
DENNIS GRUBB & ASSOCIATES, LLC	8191	12/20/2012	1170	PLAN CHECK SVCS - FIRE PREVENTION	\$5,150.00	
			1169	PLAN CHECK SVCS - FIRE PREVENTION	\$3,425.00	
			Remit to:	MIRA LOMA, CA	\$8,575.00	\$64,860.00
DENNIS LONGDYKE	8100	12/10/2012	121201	RETIREE MED BENEFIT DEC '12	\$318.73	
			Remit to:	BEAUMONT, CA	\$318.73	\$1,912.38



**City of Moreno Valley
Payment Register
For Period 12/1/2012 through 12/31/2012**

CHECKS UNDER \$25,000

<u>Vendor Name</u>	<u>Check/EFT Number</u>	<u>Payment Date</u>	<u>Invoice Number</u>	<u>Invoice Description</u>	<u>Amount</u>	<u>FYTD</u>
DEPARTMENT OF JUSTICE	215279	12/10/2012	942061	BLOOD ALCOHOL ANALYSIS FOR PD	\$595.00	
			941296	FINGERPRINTING SVCS-PD	\$49.00	
			937790	FINGERPRINTING SVCS-PD	\$1,799.00	
			941337	FINGERPRINTING SVCS-PD	\$32.00	
				Remit to: SACRAMENTO, CA	\$2,475.00	\$19,259.00
DEPARTMENT OF JUSTICE	215385	12/17/2012	932463 a	FINGERPRINTING SVCS - SRTS PROGRAM	\$416.00	
			937971 a	FINGERPRINTING SVCS - SRTS PROGRAM	\$480.00	
			932463 (HR)	FINGERPRINTING SVCS-HR DEPT/EMPLOYMENT RELATED	\$288.00	
			937971 (HR)	FINGERPRINTING SVCS-HR DEPT/EMPLOYMENT RELATED	\$569.00	
			937971 (BL)	FINGERPRINTING SVCS-BUS. LICENSE RELATED	\$96.00	
				Remit to: SACRAMENTO, CA	\$1,849.00	\$19,259.00
DLS LANDSCAPE INC.	8052	12/10/2012	13643	LANDSCAPE MAINT-ZONE A	\$10,230.00	
			13642	LANDSCAPE MAINT-CFD #1	\$2,160.00	
				Remit to: REDLANDS, CA	\$12,390.00	\$74,340.00
DLS LANDSCAPE INC.	8141	12/17/2012	13691	LANDSCAPE MAINT-ZONE A	\$10,230.00	
			13690	LANDSCAPE MAINT-CFD #1	\$2,160.00	
				Remit to: REDLANDS, CA	\$12,390.00	\$74,340.00
DMC DESIGN GROUP, INC	8192	12/20/2012	2012-131	CONSULTING SERVICES, CONTRACT ADMINISTRATION - NASON/CACTUS	\$7,289.50	
			2012-121	CONSULTING SERVICES, CONTRACT ADMINISTRATION - NASON/CACTUS	\$8,753.50	

Item No. A.4

-55-



**City of Moreno Valley
Payment Register
For Period 12/1/2012 through 12/31/2012**

CHECKS UNDER \$25,000

<u>Vendor Name</u>	<u>Check/EFT Number</u>	<u>Payment Date</u>	<u>Invoice Number</u>	<u>Invoice Description</u>	<u>Amount</u>	<u>FYTD</u>
				Remit to: CORONA, CA	\$16,043.00	\$61,779.84
D-PREP, LLC	215490	12/20/2012	1/7/13 TRAINING	TUITION FEE FOR 8 OFFICERS FOR CRITICAL INCIDENT RESPONSE CLASS	\$712.00	
				Remit to: SACRAMENTO, CA	\$712.00	\$712.00
E M W D	215200	12/03/2012	OCT-12 12/03/12	WATER CHARGES	\$540.23	
			NOV-12 12/03/12	WATER CHARGES	\$22,475.22	
				Remit to: PERRIS, CA	\$23,015.45	\$703,687.34
E M W D	215343	12/11/2012	NOV-12 12/10/12	WATER CHARGES	\$16,436.78	
				Remit to: PERRIS, CA	\$16,436.78	\$703,687.34
E.R. BLOCK PLUMBING & HEATING, INC.	8011	12/03/2012	110641	BACKFLOW DEVICE TESTS-ZONE M	\$40.00	
			110643	BACKFLOW DEVICE TESTS-ZONE E	\$200.00	
			110642	BACKFLOW DEVICE TEST-ZONE D	\$160.00	
			110793	REPLACED BACKFLOW DEVICE-ZONE E-2	\$807.06	
				Remit to: RIVERSIDE, CA	\$1,207.06	\$10,803.24
E.R. BLOCK PLUMBING & HEATING, INC.	8193	12/20/2012	110931	BACKFLOW DEVICE TESTS-ZONE D, E-1 S,	\$100.00	
			110178	REPLACED BACKFLOW DEVICE-ZONE E-1A	\$1,503.39	
				Remit to: RIVERSIDE, CA	\$1,603.39	\$10,803.24
EDITH E. HOUSER	215298	12/10/2012	121201	RETIREE MED BENEFIT DEC '12	\$318.73	
				Remit to: MORENO VALLEY, CA	\$318.73	\$1,593.65
ERNEST VIGIL	8129	12/10/2012	121201	RETIREE MED BENEFIT DEC '12	\$318.73	
				Remit to: MORENO VALLEY, CA	\$318.73	\$1,593.65

-56-

ite



**City of Moreno Valley
Payment Register
For Period 12/1/2012 through 12/31/2012**

CHECKS UNDER \$25,000

<u>Vendor Name</u>	<u>Check/EFT Number</u>	<u>Payment Date</u>	<u>Invoice Number</u>	<u>Invoice Description</u>	<u>Amount</u>	<u>FYTD</u>
ESGIL CORPORATION	215201	12/03/2012	10123164	PLAN CHECK SVCS-BLDG/SAFETY	\$442.50	
			Remit to:	SAN DIEGO, CA	\$442.50	\$1,046.2
EUGENE ROGERS	8117	12/10/2012	121201	RETIREE MED BENEFIT DEC '12	\$318.73	
			Remit to:	PEBBLE BEACH, CA	\$318.73	\$1,593.6
EVANS ENGRAVING & AWARDS	8053	12/10/2012	111612-24	SERVICE AWARDS	\$543.06	
			Remit to:	MORENO VALLEY, CA	\$543.06	\$1,130.48
EWING IRRIGATION PRODUCTS, INC.	215461	12/20/2012	5546766	IRRIGATION PARTS/SUPPLIES-GOLF COURSE	\$1,067.75	
			Remit to:	PHOENIX, AZ	\$1,067.75	\$17,583.57
EXCEL LANDSCAPE	215202	12/03/2012	74338A	LANDSCAPE MAINT-WQ BASINS	\$7,325.78	
			74725	LANDSCAPE MAINT-ZONE E-7	\$2,777.17	
			73979A	LANDSCAPE MAINT-WQ BASINS	\$6,997.43	
			Remit to:	CORONA, CA	\$17,100.38	\$56,431.77
EXCEL LANDSCAPE	215253	12/10/2012	75054	LANDSCAPE MAINT-WQ BASINS	\$7,325.78	
			75047	LANDSCAPE MAINT-ZONE E-7	\$2,777.17	
			74732A	LANDSCAPE MAINT-WQ BASINS	\$7,325.78	
			Remit to:	CORONA, CA	\$17,428.73	\$56,431.77
FALCON MANAGEMENT GROUP, INC.	215365	12/17/2012	2321PC	ELECTRONIC DATABASE SUBSCRIPTION	\$25.00	
			Remit to:	SALT LAKE CITY, UT	\$25.00	\$25.00
FIRST CHOICE COFFEE SERVICES	8012	12/03/2012	515438	COFFEE SVC-EMPLOYEE PAID	\$62.38	
			516028	COFFEE SVC-EMPLOYEE PAID	\$27.00	

Item No. A.4

157-



City of Moreno Valley
Payment Register
 For Period 12/1/2012 through 12/31/2012

CHECKS UNDER \$25,000

<u>Vendor Name</u>	<u>Check/EFT Number</u>	<u>Payment Date</u>	<u>Invoice Number</u>	<u>Invoice Description</u>	<u>Amount</u>	<u>FYTD</u>
				Remit to: ONTARIO, CA	\$89.38	\$3,682.81
FIRST CHOICE SERVICES	8054	12/10/2012	515436	EMPLOYEE PAID COFFEE SVC-CRC	\$45.65	
				Remit to: ONTARIO, CA	\$45.65	\$3,682.81
FIRST CHOICE SERVICES	8142	12/17/2012	515434	COFFEE SVC-EMPLOYEE PAID	\$62.76	
				Remit to: ONTARIO, CA	\$62.76	\$3,682.81
FORM PRNT CO FPC GRAPHCS	215203	12/03/2012	89180	FALSE ALARM CITATION NOTICE PRINTING	\$2,634.49	
				Remit to: RIVERSIDE, CA	\$2,634.49	\$4,205.49
FRANCHISE TAX BOARD	215312	12/10/2012	121129	GARNISHMENT	\$471.96	
				Remit to: SACRAMENTO, CA	\$471.96	\$2,648.69
FRANCHISE TAX BOARD	215396	12/17/2012	121215	GARNISHMENT	\$934.41	
				Remit to: SACRAMENTO, CA	\$934.41	\$2,648.69
FRAZEE PAINT & WALLCOVERINGS	215255	12/10/2012	9530501059290	GRAFFITI REMOVAL PRODUCTS	\$704.37	
				Remit to: LOS ANGELES, CA	\$704.37	\$2,758.83
GALL INC., INLAND UNIFORM	215204	12/03/2012	264723	UNIFORM PURCHASE/REPLACEMENT-POP UNIT	\$415.75	
				Remit to: PASADENA, CA	\$415.75	\$1,673.68
GALL INC., INLAND UNIFORM	215464	12/20/2012	282461	UNIFORM PURCHASE/REPLACEMENT-POP UNIT	\$181.46	
			285028	UNIFORM REPLACEMENT-TRAFFIC UNIT	\$83.81	
				Remit to: PASADENA, CA	\$265.27	\$1,673.68
GARY B. SPECK	8124	12/10/2012	121201	RETIREE MED BENEFIT DEC '12	\$318.73	



**City of Moreno Valley
Payment Register
For Period 12/1/2012 through 12/31/2012**

CHECKS UNDER \$25,000

<u>Vendor Name</u>	<u>Check/EFT Number</u>	<u>Payment Date</u>	<u>Invoice Number</u>	<u>Invoice Description</u>	<u>Amount</u>	<u>FYTD</u>
				Remit to: MORENO VALLEY, CA	\$318.73	\$1,593.6
GARY D. WAGNER	8131	12/10/2012	121201	RETIREE MED BENEFIT DEC '12	\$318.73	
				Remit to: MORENO VALLEY, CA	\$318.73	\$1,593.6
GARY M. KYLE	8095	12/10/2012	121201	RETIREE MED BENEFIT DEC '12	\$318.73	
				Remit to: PRESCOTT VALLEY, AZ	\$318.73	\$1,593.65
GENERAL SECURITY SERVICES, INC.	215205	12/03/2012	172282	SECURITY SVCS-TOWNGATE COMM CTR	\$153.40	
			171472	SECURITY SVCS-SENIOR CTR RENTALS	\$122.72	
				Remit to: WILMINGTON, CA	\$276.12	\$16,432.98
GENERAL SECURITY SERVICES, INC.	215256	12/10/2012	172235	SECURITY SVCS-SENIOR CTR RENTALS	\$214.76	
			172080	SECURITY SVCS-TOWNGATE COMM CTR	\$76.70	
			172393	SECURITY SVCS-TOWNGATE COMM CTR	\$76.70	
			172397	SECURITY SVCS-CONF & REC CTR SPECIAL EVENTS	\$76.70	
			172398	SECURITY SVCS-CONF & REC CTR SPECIAL EVENTS	\$46.02	
			172396	SECURITY SVCS-CONF & REC CTR	\$306.80	
			172350	SECURITY SVCS-LIBRARY	\$490.88	
			172298	SECURITY SVCS-LIBRARY	\$613.60	
			172296	SECURITY SVCS-MVU	\$122.72	
			172083	SECURITY SVCS-CONF & REC CTR SPECIAL EVENTS	\$122.72	
			172394	SECURITY SVCS-TOWNGATE COMM CTR	\$46.02	
			172349	SECURITY SVCS-MVU	\$153.40	

Item No. A.4

F59-



City of Moreno Valley
Payment Register
 For Period 12/1/2012 through 12/31/2012

CHECKS UNDER \$25,000

<u>Vendor Name</u>	<u>Check/EFT Number</u>	<u>Payment Date</u>	<u>Invoice Number</u>	<u>Invoice Description</u>	<u>Amount</u>	<u>FYTD</u>
GENERAL SECURITY SERVICES, INC.	215256	12/10/2012	172399	SECURITY SVCS-SENIOR CTR RENTALS	\$184.08	
			172337	SECURITY SVCS-CONF & REC CTR SPECIAL EVENTS	\$61.36	
			172285	SECURITY SVCS-CONF & REC CTR	\$306.80	
			172336	SECURITY SVCS-CONF & REC CTR SPECIAL EVENTS	\$230.10	
				Remit to: WILMINGTON, CA	\$3,129.36	\$16,432.98
GENERAL SECURITY SERVICES, INC.	215367	12/17/2012	171909A	SECURITY SVCS-CRC SPECIAL EVENTS	\$46.02	
			172024	SECURITY SVCS-CONF & REC CTR	\$306.80	
			172480	SECURITY SVCS-TOWNGATE COMM CTR	\$61.36	
			172482	SECURITY SVCS-CONF & REC CTR	\$306.80	
			172025	SECURITY SVCS-CRC SPECIAL EVENTS	\$368.16	
			172481	SECURITY SVCS-TOWNGATE COMM CTR	\$61.36	
			172483	SECURITY SVCS-CRC SPECIAL EVENTS	\$322.14	
			172283	SECURITY SVCS-SENIOR CTR RENTALS	\$130.39	
			172135	SECURITY SVCS-CRC SPECIAL EVENTS	\$76.70	
				Remit to: WILMINGTON, CA	\$1,679.73	\$16,432.98
GENERAL SECURITY SERVICES, INC.	215465	12/20/2012	172411	SECURITY SVCS-LIBRARY	\$613.60	
			172484	SECURITY SVCS-LIBRARY	\$368.16	
				Remit to: WILMINGTON, CA	\$981.76	\$16,432.98
GEORGE E. PRICE	8114	12/10/2012	121201	RETIREE MED BENEFIT DEC '12	\$318.73	
				Remit to: MORENO VALLEY, CA	\$318.73	\$1,593.65

-60-



City of Moreno Valley
Payment Register
 For Period 12/1/2012 through 12/31/2012

CHECKS UNDER \$25,000

<u>Vendor Name</u>	<u>Check/EFT Number</u>	<u>Payment Date</u>	<u>Invoice Number</u>	<u>Invoice Description</u>	<u>Amount</u>	<u>FYTD</u>
GIBBS, GIDEN, LOCHER, TURNER & SENET LLP	8055	12/10/2012	217278-003	LEGAL SERVICES - SR-60 NASON	\$617.00	
			Remit to:	LOS ANGELES, CA	\$617.00	\$77,441.2
GINA HENDERSON	215405	12/17/2012	FALL 2012	TUITION REIMBURSEMENT	\$1,500.00	
			Remit to:	MORENO VALLEY, CA	\$1,500.00	\$1,500.0
GLENN C. WAGGONER, JR.	8130	12/10/2012	121201	RETIREE MED BENEFIT 10/31/12 & 11/30/12, PD DEC '12	\$553.16	
			Remit to:	MORENO VALLEY, CA	\$553.16	\$1,659.48
GLOBAL SOFTWARE, INC	8013	12/03/2012	41999	SPREADSHEET SERVER PROFILE NWS GL	\$2,440.00	
			Remit to:	RALEIGH, NC	\$2,440.00	\$2,806.00
GLOBAL SOFTWARE, INC	8143	12/17/2012	42090	SPREADSHEET SERVER-PARTIAL YEAR MAINTENANCE	\$366.00	
			Remit to:	RALEIGH, NC	\$366.00	\$2,806.00
GRACE BACHER	215290	12/10/2012	121201	RETIREE MED BENEFIT DEC '12	\$318.73	
			Remit to:	HEMET, CA	\$318.73	\$1,593.65
GREGORY CAIN	8074	12/10/2012	121201	RETIREE MED BENEFIT DEC '12	\$318.73	
			Remit to:	TAMPA, FL	\$318.73	\$1,593.65
GUARDSMARK	8014	12/03/2012	5246120	SECURITY GUARD SERVICES FOR CITY HALL	\$357.20	
			Remit to:	RANCHO CUCAMONGA, CA	\$357.20	\$10,090.90
GUARDSMARK	8056	12/10/2012	5247123	SECURITY SVCS-CITY HALL	\$357.20	
			Remit to:	RANCHO CUCAMONGA, CA	\$357.20	\$10,090.90
GUARDSMARK	8194	12/20/2012	5248117	SECURITY SVCS-CITY HALL	\$267.90	

Item No. A.4

61-



**City of Moreno Valley
Payment Register
For Period 12/1/2012 through 12/31/2012**

CHECKS UNDER \$25,000

<u>Vendor Name</u>	<u>Check/EFT Number</u>	<u>Payment Date</u>	<u>Invoice Number</u>	<u>Invoice Description</u>	<u>Amount</u>	<u>FYTD</u>
GUARDSMARK	8194	12/20/2012	5249118	SECURITY SVCS-CITY HALL	\$357.20	
			Remit to:	RANCHO CUCAMONGA, CA	\$625.10	\$10,090.90
HABITAT FOR HUMANITY RIVERSIDE	215206	12/03/2012	OCTOBER 2012	HELPING HANDS REIMBURSEMENT	\$1,320.58	
			JULY-SEPT 2012	HELPING HANDS REIMBURSEMENT	\$5,387.17	
			Remit to:	RIVERSIDE, CA	\$6,707.75	\$12,486.84
HONDA YAMAHA OF REDLANDS	8058	12/10/2012	8639	MAINT. & REPAIRS-LABOR & PARTS-TRAFFIC MOTORCYCLES	\$283.43	
			Remit to:	REDLANDS, CA	\$283.43	\$12,097.79
HONDA YAMAHA OF REDLANDS	8195	12/20/2012	9067	MAINT. & REPAIRS-LABOR & PARTS-TRAFFIC MOTORCYCLES	\$633.14	
			Remit to:	REDLANDS, CA	\$633.14	\$12,097.79
HUGO SOSA	215412	12/17/2012	DEC-2012	INSTRUCTOR SVCS-TRADITIONAL KARATEDO CLASS	\$60.00	
			NOV-2012	INSTRUCTOR SVCS-TRADITIONAL KARATEDO CLASS	\$120.00	
			Remit to:	ELK GROVE, CA	\$180.00	\$630.00
HUMBERTO SILVA	215228	12/03/2012	11/6/12 MILEAGE	MILEAGE REIMBURSEMENT-GOVT. DEVICE & DEMO EVENT/COSTA MESA	\$58.83	
			Remit to:	MORENO VALLEY, CA	\$58.83	\$58.83
HUNSAKER & ASSOCIATES, INC.	215466	12/20/2012	12080310	CONSULTING SERVICES, SURVEY - PERRIS BLVD. WIDENING	\$18,986.00	
			Remit to:	IRVINE, CA	\$18,986.00	\$36,405.00
ICMA RETIREMENT CORP	8181	12/13/2012	DC457121213	3205-DEFERRED COMP - 457	\$9,800.01	

-62-



**City of Moreno Valley
Payment Register
For Period 12/1/2012 through 12/31/2012**

CHECKS UNDER \$25,000

<u>Vendor Name</u>	<u>Check/EFT Number</u>	<u>Payment Date</u>	<u>Invoice Number</u>	<u>Invoice Description</u>	<u>Amount</u>	<u>FYTD</u>
				Remit to: BALTIMORE, MD	\$9,800.01	\$108,724.8
ICMA RETIREMENT CORP	8295	12/27/2012	DC457121227	3213-DEFERRED COMP-457	\$9,824.69	
				Remit to: BALTIMORE, MD	\$9,824.69	\$108,724.8
ICR DOORS	8196	12/20/2012	491	MAINT. OF ROLL-UP DOORS-GATE 7-PSB	\$382.50	
			490	MAINT. OF ROLL-UP DOORS-GATE 7-PSB	\$288.75	
			514	MAINT. OF ROLL-UP DOOR-GATE 3-PSB	\$232.00	
				Remit to: SAN BERNARDINO, CA	\$903.25	\$4,642.71
IES COMMERCIAL, INC	215257	12/10/2012	93723	REPAIR SVCS-LADIES LADIES LOCKERROOM & FD SIDE ADM DOOR	\$270.00	
			93250	REPLACED READER/KEYPAD FOR KENNEL DOOR AT A/S	\$972.20	
				Remit to: TEMPE, AZ	\$1,242.20	\$1,242.20
ING USA ANNUITY & LIFE INS. CO	215397	12/17/2012	121215	NON-EXEMPT ANNUITY	\$400.00	
				Remit to: DES MOINES, IA	\$400.00	\$2,400.00
INLAND EMPIRE PROPERTY SERVICE INC	8015	12/03/2012	3110	NUSIANCE ABATEMENT SERVICES	\$254.00	
			3111	NUSIANCE ABATEMENT SERVICES	\$72.00	
				Remit to: MORENO VALLEY, CA	\$326.00	\$37,700.84
INLAND EMPIRE PROPERTY SERVICE INC	8059	12/10/2012	3112	NUISANCE ABATEMENT SVCS-24307 BAIRNDALE DR	\$266.50	
			3114	NUISANCE ABATEMENT SVCS-13965 PEPPER ST	\$102.00	
			3115	NUISANCE ABATEMENT SVCS-14281 CHANTRY	\$1,469.00	

Item No. A.4

-63-



City of Moreno Valley
Payment Register
 For Period 12/1/2012 through 12/31/2012

CHECKS UNDER \$25,000

<u>Vendor Name</u>	<u>Check/EFT Number</u>	<u>Payment Date</u>	<u>Invoice Number</u>	<u>Invoice Description</u>	<u>Amount</u>	<u>FYTD</u>
				Remit to: MORENO VALLEY, CA	\$1,837.50	\$37,700.84
INLAND EMPIRE PROPERTY SERVICE INC	8197	12/20/2012	3122	WEED ABATEMENT SVCS-POORMANS RES.	\$2,502.00	
				Remit to: MORENO VALLEY, CA	\$2,502.00	\$37,700.84
INLAND LIBRARY SYSTEM	215258	12/10/2012	MVPL2012/2013	MEMBERSHIP DUES FOR 2012/2013	\$1,952.00	
				Remit to: SAN BERNARDINO, CA	\$1,952.00	\$1,952.00
INSIDE PLANTS, INC.	8016	12/03/2012	44794	MONTHLY PLANT MAINTENANCE-CRC	\$320.00	
				Remit to: CORONA, CA	\$320.00	\$1,600.00
INSIDE PLANTS, INC.	215368	12/17/2012	45168	INDOOR PLANT MAINTENANCE-CRC-DEC12	\$320.00	
				Remit to: CORONA, CA	\$320.00	\$320.00
ISAAC CHAPPELL	8077	12/10/2012	121201	RETIREE MED BENEFIT DEC '12	\$318.73	
				Remit to: MORENO VALLEY, CA	\$318.73	\$1,593.65
J D H CONTRACTING	8060	12/10/2012	112912-01	ADA IMPROVEMENTS-JFK PARK	\$4,618.00	
				Remit to: RIVERSIDE, CA	\$4,618.00	\$65,072.90
JAMES TUNTLAND	8128	12/10/2012	121201	RETIREE MED BENEFIT DEC '12	\$271.44	
				Remit to: PRESCOTT, AZ	\$271.44	\$1,357.20
JAMS, INC.	215259	12/10/2012	0002749722-210	MEDIATION SVCS-RE: AEI CASC ENG'G.	\$2,623.87	
				Remit to: LOS ANGELES, CA	\$2,623.87	\$2,623.87
JANELLE KEPLER	8146	12/17/2012	DEC-12/43885	INSTRUCTOR SVCS-CHEERLEADING CLASS	\$224.00	
			DEC-12/44944	INSTRUCTOR SVCS-CHEERLEADING CLASS	\$112.00	
				Remit to: MORENO VALLEY, CA	\$336.00	\$2,828.00



**City of Moreno Valley
Payment Register
For Period 12/1/2012 through 12/31/2012**

CHECKS UNDER \$25,000

<u>Vendor Name</u>	<u>Check/EFT Number</u>	<u>Payment Date</u>	<u>Invoice Number</u>	<u>Invoice Description</u>	<u>Amount</u>	<u>FYTD</u>
JANNEY & JANNEY ATTORNEY SVCS, INC.	215260	12/10/2012	00121133036	MONTHLY RETAINER-DELIVERY OF COURT FILINGS-DEC12	\$75.00	
				Remit to: RIVERSIDE, CA	\$75.00	\$450.00
JDEDGE SOFTWARE, LLC	8061	12/10/2012	286	HR & PAYROLL DATA CONVERSION INTO NEW ERP	\$8,413.54	
			285	HR & PAYROLL DATA CONVERSION INTO NEW ERP	\$9,187.95	
				Remit to: KRUGERVILLE, TX	\$17,601.49	\$179,881.90
JDEDGE SOFTWARE, LLC	8145	12/17/2012	288	HR & PAYROLL DATA CONVERSION INTO NEW ERP	\$2,520.00	
			287	HR & PAYROLL DATA CONVERSION INTO NEW ERP	\$8,800.00	
				Remit to: KRUGERVILLE, TX	\$11,320.00	\$179,881.90
JOHN FEENSTRA	8080	12/10/2012	121201	RETIREE MED BENEFIT DEC '12	\$361.25	
				Remit to: REDLANDS, CA	\$361.25	\$1,806.25
JOHN FRESQUEZ	215366	12/17/2012	112512	SPORTS OFFICIATING SERVICES	\$60.00	
			111512	SPORTS OFFICIATING SERVICES	\$60.00	
			120212	SPORTS OFFICIATING SERVICES	\$60.00	
				Remit to: MORENO VALLEY, CA	\$180.00	\$1,080.00
JOHN HARDING	215295	12/10/2012	121201	RETIREE MED BENEFIT DEC '12	\$318.73	
				Remit to: BANNING, CA	\$318.73	\$1,593.65
JOHN RUSSO	8120	12/10/2012	121201	RETIREE MED BENEFIT DEC '12	\$225.99	
				Remit to: RANCHO MIRAGE, CA	\$225.99	\$1,129.95

Item No. A.4

-65-



City of Moreno Valley
Payment Register
 For Period 12/1/2012 through 12/31/2012

CHECKS UNDER \$25,000

<u>Vendor Name</u>	<u>Check/EFT Number</u>	<u>Payment Date</u>	<u>Invoice Number</u>	<u>Invoice Description</u>	<u>Amount</u>	<u>FYTD</u>
JOHN W. STRICKLER II	8127	12/10/2012	121201	RETIREE MED BENEFIT DEC '12	\$318.73	
			Remit to:	SAN BERNARDINO, CA	\$318.73	\$1,274.92
JORRY KEITH	215406	12/17/2012	NOV-2012	INSTRUCTOR SVCS-COMIC BOOK CREATION CLASS	\$144.00	
			Remit to:	FONTANA, CA	\$144.00	\$624.00
JOSEPH C. BAUTISTA	8072	12/10/2012	121201	RETIREE MED BENEFIT DEC '12	\$318.73	
			Remit to:	FONTANA, CA	\$318.73	\$1,593.65
JOSEPH HSU	215376	12/17/2012	0000001	CONSULTING SERVICES-WATER UTILITY SVC-EDGEMONT AREA	\$3,000.00	
			Remit to:	HENDERSON, NV	\$3,000.00	\$3,000.00
JOSEPHINE LAFATA	8096	12/10/2012	121201	RETIREE MED BENEFIT DEC '12	\$318.73	
			Remit to:	MORENO VALLEY, CA	\$318.73	\$1,593.65
JTB SUPPLY CO., INC.	8017	12/03/2012	95405	BATTERY BACK UP SERVICE CABINET	\$8,296.75	
			Remit to:	ORANGE, CA	\$8,296.75	\$16,615.06
JTB SUPPLY CO., INC.	215261	12/10/2012	95469	TRAFFIC SIGNAL SUPPLIES	\$204.73	
			95458	TRAFFIC SIGNAL SUPPLIES	\$9,131.81	
			Remit to:	ORANGE, CA	\$9,336.54	\$25,606.79
JUDITH A. NIEBURGER	215301	12/10/2012	121201	RETIREE MED BENEFIT DEC '12	\$401.42	
			Remit to:	MORENO VALLEY, CA	\$401.42	\$2,007.10
KATHLEEN DALE	8079	12/10/2012	121201	RETIREE MED BENEFIT DEC '12	\$318.73	
			Remit to:	MORENO VALLEY, CA	\$318.73	\$1,593.65



**City of Moreno Valley
Payment Register
For Period 12/1/2012 through 12/31/2012**

CHECKS UNDER \$25,000

<u>Vendor Name</u>	<u>Check/EFT Number</u>	<u>Payment Date</u>	<u>Invoice Number</u>	<u>Invoice Description</u>	<u>Amount</u>	<u>FYTD</u>
KIMBERLY SCHMITZ	215496	12/20/2012	12/4/12 MILEAGE	MILEAGE REIMBURSEMENT-ADMINISURE WORKERS' COMP UPDATE	\$42.74	
			Remit to:	GRAND TERRACE, CA	\$42.74	\$61.00
KOLA-FM 99.9	215370	12/17/2012	39022	BROADCASTS OF OIL FILTER RECYCLING CAMPAIGN	\$3,980.00	
			Remit to:	REDLANDS, CA	\$3,980.00	\$3,980.00
KYLE KOLLAR	8093	12/10/2012	121201	RETIREE MED BENEFIT DEC '12	\$318.73	
			Remit to:	MORENO VALLEY, CA	\$318.73	\$1,593.65
LARRY W. WARD, COUNTY ASSESSOR	215186	12/03/2012	11158-A	REPRODUCE MAPS-SDA	\$6.75	
			11158-D	REPRODUCE MAPS-SDA	\$6.75	
			11158-C	REPRODUCE MAPS-SDA	\$6.75	
			11158-B	REPRODUCE MAPS-SDA	\$6.75	
			Remit to:	RIVERSIDE, CA	\$27.00	\$82.37
LAWYERS TITLE COMPANY	8172	12/04/2012	W121201	LAND ACQUISITION-MORENO VALLEY INTERCHANGE PROJ-APN473-160-007	\$15,096.00	
			Remit to:	NEWPORT BEACH, CA	\$15,096.00	\$239,312.50
LEAD TECH ENVIRONMENTAL	215262	12/10/2012	7557	LEAD TECH SCREENING-MHG EDWARD SILVA SPC#75	\$240.00	
			Remit to:	CARLSBAD, CA	\$240.00	\$240.00
LEARNING EXPRESS, LLC	215263	12/10/2012	SO-4263	ANNUAL DATABASE RENEWAL SUBSCRIPTION	\$5,270.00	
			Remit to:	NEW YORK, NY	\$5,270.00	\$5,270.00
LISA A. MORGAN	8109	12/10/2012	121201	RETIREE MED BENEFIT DEC '12	\$318.73	

Item No. A.4

-67-



City of Moreno Valley
Payment Register
 For Period 12/1/2012 through 12/31/2012

CHECKS UNDER \$25,000

<u>Vendor Name</u>	<u>Check/EFT Number</u>	<u>Payment Date</u>	<u>Invoice Number</u>	<u>Invoice Description</u>	<u>Amount</u>	<u>FYTD</u>
				Remit to: MENTONE, CA	\$318.73	\$1,593.65
LORI C. SCHIEFELBEIN	215271	12/10/2012	NOV 2012	CONSULTANT SVCS-ROTATIONAL TOW PROGRAM	\$1,196.25	
				Remit to: BULLHEAD CITY, AZ	\$1,196.25	\$6,407.50
LORI C. SCHIEFELBEIN	215305	12/10/2012	121201	RETIREE MED BENEFIT NOV '12, PD DEC '12	\$318.73	
				Remit to: BULLHEAD CITY, AZ	\$318.73	\$2,679.90
LOUIS A. ROSSON	8119	12/10/2012	121201	RETIREE MED BENEFIT DEC '12	\$165.81	
			121201a	RETIREE MED BENEFIT DEC '12	\$96.50	
				Remit to: PERRIS, CA	\$262.31	\$1,408.05
LOUIS MESSIN	8104	12/10/2012	121201	RETIREE MED BENEFIT DEC '12	\$318.73	
				Remit to: BULLHEAD CITY, AZ	\$318.73	\$1,593.65
MALCOLM SMITH MOTORSPORTS	215207	12/03/2012	100013290	MAINT. & REPAIRS-LABOR & PARTS-TRAFFIC MOTORCYCLES	\$403.98	
			100019720	MAINT. & REPAIRS-LABOR & PARTS-TRAFFIC MOTORCYCLES	\$202.27	
			100022735	MAINT. & REPAIRS-LABOR & PARTS-TRAFFIC MOTORCYCLES	\$1,504.19	
				Remit to: RIVERSIDE, CA	\$2,110.44	\$15,639.27
MARGARET AYARS	8071	12/10/2012	121201	RETIREE MED BENEFIT AUG-DEC'12, PD DEC '12	\$1,593.65	
				Remit to: YUCAIPA, CA	\$1,593.65	\$1,593.65
MARIA A. SMITH	8123	12/10/2012	121201	RETIREE MED BENEFIT DEC '12	\$318.73	
				Remit to: MORENO VALLEY, CA	\$318.73	\$1,593.65

-68-



**City of Moreno Valley
Payment Register
For Period 12/1/2012 through 12/31/2012**

CHECKS UNDER \$25,000

<u>Vendor Name</u>	<u>Check/EFT Number</u>	<u>Payment Date</u>	<u>Invoice Number</u>	<u>Invoice Description</u>	<u>Amount</u>	<u>FYTD</u>
MARINA LANDSCAPE, INC	8018	12/03/2012	8216101200	LANDSCAPE MAINT-ZONE E-1/E-1A-OCT12	\$5,733.34	
				Remit to: ANAHEIM, CA	\$5,733.34	\$53,052.00
MARINA LANDSCAPE, INC	8198	12/20/2012	8216111200	LANDSCAPE MAINT-ZONE E-1/E-1A-NOV12	\$5,733.34	
				Remit to: ANAHEIM, CA	\$5,733.34	\$53,052.00
MARIPOSA HORTICULTURAL	8199	12/20/2012	57601	LANDSCAPE MAINT-ZONE DSG-2-NOV12	\$12,857.13	
			57602	LANDSCAPE SVCS-TR23046 DSG2	\$7,418.00	
				Remit to: IRWINDALE, CA	\$20,275.13	\$102,301.21
MARK E. MINARD	8106	12/10/2012	121201	RETIREE MED BENEFIT DEC '12	\$318.73	
				Remit to: REDLANDS, CA	\$318.73	\$1,593.65
MARK L. ADAMS	8070	12/10/2012	121201	RETIREE MED BENEFIT DEC '12	\$318.73	
				Remit to: REDLANDS, CA	\$318.73	\$1,593.65
MARLENE C. GRIFFIN	8084	12/10/2012	121201	RETIREE MED BENEFIT DEC '12	\$318.73	
				Remit to: GREEN VALLEY, AZ	\$318.73	\$1,593.65
MARTHA SPENCER	8125	12/10/2012	121201	RETIREE MED BENEFIT DEC '12	\$225.99	
				Remit to: MORENO VALLEY, CA	\$225.99	\$1,129.95
MARTIN D. HANES	8088	12/10/2012	121201	RETIREE MED BENEFIT DEC '12	\$318.73	
				Remit to: MORENO VALLEY, CA	\$318.73	\$1,593.65
MCCAIN TRAFFIC SUPPLY	215208	12/03/2012	INV0158417	LED GEL 12"BALL RED DR6-RTFB-20A-22	\$1,203.57	
			INV0158405	333L 4 DOOR CABINET	\$11,257.75	
				Remit to: VISTA, CA	\$12,461.32	\$35,434.72

Item No. A.4

1-69-



City of Moreno Valley
Payment Register
 For Period 12/1/2012 through 12/31/2012

CHECKS UNDER \$25,000

<u>Vendor Name</u>	<u>Check/EFT Number</u>	<u>Payment Date</u>	<u>Invoice Number</u>	<u>Invoice Description</u>	<u>Amount</u>	<u>FYTD</u>
MERCHANTS LANDSCAPE SERVICES INC	8020	12/03/2012	38729	LANDSCAPE MAINT-ZONE E3A-OCT12	\$181.70	
			Remit to:	Santa Ana, CA	\$181.70	\$28,855.64
MERCHANTS LANDSCAPE SERVICES INC	8062	12/10/2012	38777	LANDSCAPE MAINT-ZONE E3 & E3A-NOV12	\$11,433.86	
			38776	LANDSCAPE MAINT-ZONE E8,E12,E14,E15-NOV12	\$6,765.97	
			Remit to:	Santa Ana, CA	\$18,199.83	\$28,855.64
MERCHANTS LANDSCAPE SERVICES INC	8200	12/20/2012	38936	LANDSCAPE MAINT-ZONE E3 ADDL WORK-NOV12	\$90.00	
			38934	LANDSCAPE MAINT-ZONE E3 ADDL WORK-NOV12	\$714.37	
			38935	LANDSCAPE MAINT-ZONE E3 ADDL WORK-NOV12	\$1,150.00	
			Remit to:	Santa Ana, CA	\$1,954.37	\$28,855.64
MERCHANTS LANDSCAPE SERVICES, INC.	8021	12/03/2012	38728	LANDSCAPE MAINT-ZONE E12 ADDL WORK-OCT12	\$323.43	
			Remit to:	MONTEREY PARK, CA	\$323.43	\$49,839.75
MERCHANTS LANDSCAPE SERVICES, INC.	8201	12/20/2012	38933	LANDSCAPE MAINT-ZONE E12 ADDL WORK	\$198.62	
			Remit to:	MONTEREY PARK, CA	\$198.62	\$49,839.75
METROPCS WIRELESS, INC.	215209	12/03/2012	738970	CELLULAR TECH EXTRACTION & LOCATOR SVCS.	\$50.00	
			Remit to:	DALLAS, TX	\$50.00	\$50.00
MICHAEL R. RAFTERY	215226	12/03/2012	CASE RIC 1200245	MEDIATION SVCS RE: J. TEAGUE ON 10/30/12 - 1/3 SHARE OF COST	\$416.67	
			Remit to:	RIVERSIDE, CA	\$416.67	\$416.67

-70-



**City of Moreno Valley
Payment Register
For Period 12/1/2012 through 12/31/2012**

CHECKS UNDER \$25,000

<u>Vendor Name</u>	<u>Check/EFT Number</u>	<u>Payment Date</u>	<u>Invoice Number</u>	<u>Invoice Description</u>	<u>Amount</u>	<u>FYTD</u>
MICHAEL SCHUMAN	8121	12/10/2012	121201	RETIREE MED BENEFIT DEC '12	\$318.73	
				Remit to: RIVERSIDE, CA	\$318.73	\$1,593.6
MIKE MOLLIKA	8107	12/10/2012	121201	RETIREE MED BENEFIT DEC '12	\$401.42	
				Remit to: DUNNELLON, FL	\$401.42	\$2,007.1
MONROVIA GROWERS	8165	12/17/2012	928757	PLANT MATERIALS PER QUOTE 1285954	\$6,522.02	
				Remit to: AZUSA, CA	\$6,522.02	\$13,044.04
MONROVIA GROWERS	215448	12/17/2012	928757	PLANT MATERIALS PER QUOTE 1285954	\$6,522.02	
				Remit to: AZUSA, CA	\$6,522.02	\$13,044.04
MONTGOMERY PLUMBING INC	215210	12/03/2012	112012	PLUMBING REPAIRS-PUBLIC SAFETY BLDG.	\$275.00	
			111312	PLUMBING REPAIRS-SENIOR CTR	\$175.00	
				Remit to: MORENO VALLEY, CA	\$450.00	\$1,258.75
MONTGOMERY PLUMBING INC	215467	12/20/2012	120612	PLUMBING REPAIRS-PSB	\$275.00	
			071712	PLUMBING REPAIRS-PSB	\$80.25	
			090712	PLUMBING REPAIRS-ANIMAL SHELTER	\$275.00	
				Remit to: MORENO VALLEY, CA	\$630.25	\$1,258.75
MORENO VALLEY	8180	12/13/2012	MO121213	3204-MVCEA DUES	\$1,437.00	
				Remit to: MORENO VALLEY, CA	\$1,437.00	\$18,257.00
MORENO VALLEY	8186	12/03/2012	MO121203	3197-MVCEA DUES	\$1,429.50	
				Remit to: MORENO VALLEY, CA	\$1,429.50	\$18,257.00
MORENO VALLEY	8298	12/27/2012	MO121227	3212-MVCEA DUES	\$1,427.50	

Item No. A.4

F-71-



City of Moreno Valley
Payment Register
 For Period 12/1/2012 through 12/31/2012

CHECKS UNDER \$25,000

<u>Vendor Name</u>	<u>Check/EFT Number</u>	<u>Payment Date</u>	<u>Invoice Number</u>	<u>Invoice Description</u>	<u>Amount</u>	<u>FYTD</u>
				Remit to: MORENO VALLEY, CA	\$1,427.50	\$18,257.00
MORENO VALLEY CHAMBER OF COMMERCE	215345	12/11/2012	3518	WAKE-UP MEETING ATTENDANCE-11/28/12	\$75.00	
				Remit to: MORENO VALLEY, CA	\$75.00	\$19,340.00
MORENO VALLEY GATEWAY, LLC	8202	12/20/2012	2147	LEASE-FACILITIES ANNEX-DEC12	\$2,458.97	
			2149	LEASE-SUITES 5-9 ESA ANNEX-DEC12	\$9,207.72	
			2148	LEASE-T/S ANNEX-DEC12	\$5,475.90	
				Remit to: SAN JUAN CAPISTRANO, CA	\$17,142.59	\$85,712.95
MORENO VALLEY HISPANIC CHAMBER OF COMMERCE	215346	12/11/2012	12/4/12 ADELANTE	ADELANTE MEETING ATTENDANCE	\$40.00	
				Remit to: MORENO VALLEY, CA	\$40.00	\$6,330.00
MUSICSTAR	215372	12/17/2012	DEC-2012	INSTRUCTOR SVCS-PIANO FOR KIDS CLASSES	\$459.00	
				Remit to: RIVERSIDE, CA	\$459.00	\$3,834.00
MUSICSTAR	215407	12/17/2012	NOV-2012	INSTRUCTOR SVCS-GUITAR & PIANO FOR KIDS CLASSES	\$540.00	
				Remit to: RIVERSIDE, CA	\$540.00	\$3,834.00
NANCY A. FOSTER	8081	12/10/2012	121201	RETIREE MED BENEFIT DEC '12	\$318.73	
				Remit to: GRASS VALLEY, CA	\$318.73	\$1,593.65
NANCY POUNDS	8113	12/10/2012	121201	RETIREE MED BENEFIT NOV '12, PD DEC '12	\$318.73	
				Remit to: BOISE, ID	\$318.73	\$1,912.38
NATIONWIDE RETIREMENT SOLUTIONS	8178	12/13/2012	DC457121213FICA	3202-PST DEF COMP FOR FICA	\$3,030.51	
				Remit to: COLUMBUS, OH	\$3,030.51	\$38,152.22

-72-



**City of Moreno Valley
Payment Register
For Period 12/1/2012 through 12/31/2012**

CHECKS UNDER \$25,000

<u>Vendor Name</u>	<u>Check/EFT Number</u>	<u>Payment Date</u>	<u>Invoice Number</u>	<u>Invoice Description</u>	<u>Amount</u>	<u>FYTD</u>
NATIONWIDE RETIREMENT SOLUTIONS	8184	12/04/2012	DC457121129FICA	3195-PST DEF COMP FOR FICA	\$2,476.56	
			Remit to:	COLUMBUS, OH	\$2,476.56	\$38,152.22
NATIONWIDE RETIREMENT SOLUTIONS	8185	12/04/2012	NW457121129	3196-DEFERRED COMP - 457 & 401(A)	\$1,321.58	
			Remit to:	COLUMBUS, OH	\$1,321.58	\$335,812.8
NATIONWIDE RETIREMENT SOLUTIONS	8296	12/27/2012	DC457121227FICA	3210-PST DEF COMP FICA	\$3,501.48	
			Remit to:	COLUMBUS, OH	\$3,501.48	\$38,152.22
NEW WORLD SYSTEMS, CORP.	8022	12/03/2012	024152	TRAVEL EXPENSES-ERP REPLACEMENT PROJECT	\$600.00	
			024039	TRAVEL EXPENSES-ERP REPLACEMENT PROJECT	\$600.00	
			Remit to:	TROY, MI	\$1,200.00	\$200,568.95
NEXUS IS, INC.	8134	12/10/2012	JC625491	CISCO IE 3000 SWITCHES/1000MBPS SINGLE MODE RUGGED FOR TRAFFIC	\$11,514.70	
			Remit to:	VALENCIA, CA	\$11,514.70	\$37,929.77
NEXUS IS, INC.	215339	12/10/2012	JC625491	CISCO IE 3000 SWITCHES/1000MBPS SINGLE MODE RUGGED FOR TRAFFIC	\$11,514.70	
			Remit to:	VALENCIA, CA	\$11,514.70	\$37,929.77
NOLAN MATHIS	8102	12/10/2012	121201	RETIREE MED BENEFIT OCT '12, PD DEC '12	\$279.80	
			Remit to:	JACKSON, KY	\$279.80	\$1,399.00
NORMA PERRY	215303	12/10/2012	121201	RETIREE MED BENEFIT DEC '12	\$318.73	
			Remit to:	PIONEER, CA	\$318.73	\$1,593.65
NORMAN A. TRAUB ASSOCIATES	215264	12/10/2012	12115	PROFESSIONAL SVCS	\$1,500.00	

Item No. A.4

-73-



City of Moreno Valley
Payment Register
 For Period 12/1/2012 through 12/31/2012

CHECKS UNDER \$25,000

<u>Vendor Name</u>	<u>Check/EFT Number</u>	<u>Payment Date</u>	<u>Invoice Number</u>	<u>Invoice Description</u>	<u>Amount</u>	<u>FYTD</u>
				Remit to: YORBA LINDA, CA	\$1,500.00	\$13,831.31
OAKLEY SALES CORP	215265	12/10/2012	721580343	SAFETY EYE WEAR FOR PD MOTOR OFFICERS	\$737.78	
				Remit to: LOS ANGELES, CA	\$737.78	\$840.80
OWEN CHRISTIAN	8078	12/10/2012	121201	RETIREE MED BENEFIT DEC '12	\$225.99	
				Remit to: MORENO VALLEY, CA	\$225.99	\$1,129.95
PACIFIC GREEN HORTICULTURAL	8023	12/03/2012	14299	TURF FERTILIZATION & PEST CONTROL SVCS- ZONE E-7 & E-14	\$101.91	
			14300	TURF FERTILIZATION & PEST CONTROL SVCS- ZONE E-7 & E-14	\$101.91	
				Remit to: UPLAND, CA	\$203.82	\$1,007.64
PACIFIC TELEMAGEMENT SERVICES	8204	12/20/2012	469314	PAYPHONE SERVICES	\$250.56	
			469314 a	PAYPHONE SERVICES	\$62.64	
				Remit to: SAN RAMON, CA	\$313.20	\$1,941.84
PAINING BY ZEB BODE	8024	12/03/2012	122011	PAINTING OF SOUTH ENTRANCE AT SENIOR CENTER	\$3,700.00	
			122611	PAINTING OF LIGHT POLES AT SENIOR CENTER	\$3,380.00	
				Remit to: NORCO, CA	\$7,080.00	\$35,613.00
PATH OF LIFE MINISTRIES	215266	12/10/2012	CDBG MV 1-12/13	CDBG PRGM-REIMB. FOR TRANSITIONAL SHELTER PRGM SVCS	\$15,850.00	
				Remit to: RIVERSIDE, CA	\$15,850.00	\$15,850.00
PATRICIA A. KING	215299	12/10/2012	121201	RETIREE MED BENEFIT DEC '12	\$271.44	
				Remit to: LAS VEGAS, NV	\$271.44	\$1,357.20



**City of Moreno Valley
Payment Register
For Period 12/1/2012 through 12/31/2012**

CHECKS UNDER \$25,000

<u>Vendor Name</u>	<u>Check/EFT Number</u>	<u>Payment Date</u>	<u>Invoice Number</u>	<u>Invoice Description</u>	<u>Amount</u>	<u>FYTD</u>
PATRICIA A. MORA	8108	12/10/2012	121201	RETIREE MED BENEFIT DEC '12	\$318.73	
			Remit to:	MORENO VALLEY, CA	\$318.73	\$1,593.6
PATRICK BECKNER	8073	12/10/2012	121201	RETIREE MED BENEFIT SEPT-NOV '12, PD DEC '12	\$703.20	
			Remit to:	MURRIETA, CA	\$703.20	\$2,317.2
PB AMERICAS, INC.	215374	12/17/2012	AR 496565	ENGINEERING SERVICES - SR-60/NASON INTRCHG.	\$20,169.16	
			Remit to:	SAN BERNARDINO, CA	\$20,169.16	\$20,169.16
PERS LONG TERM CARE PROGRAM	215315	12/10/2012	121115	LONG TERM CARE INSURANCE	\$458.63	
			Remit to:	PASADENA, CA	\$458.63	\$5,503.56
PERS LONG TERM CARE PROGRAM	215316	12/10/2012	121129	LONG TERM CARE INSURANCE	\$458.63	
			Remit to:	PASADENA, CA	\$458.63	\$5,503.56
PERS LONG TERM CARE PROGRAM	215399	12/17/2012	121215	LONG TERM CARE INSURANCE	\$458.63	
			Remit to:	PASADENA, CA	\$458.63	\$5,503.56
PIP PRINTING	8025	12/03/2012	53402 - BAL DUE	REMINDER POSTCARDS PRINTING/ADDRESSING FOR BUSINESS LIC. RENEWAL	\$926.43	
			Remit to:	MORENO VALLEY, CA	\$926.43	\$2,688.75
PROFESSIONAL COMMUNICATION NETWORK PCN	215267	12/10/2012	086400439	LIVE ANSWERING SERVICE FOR TOW PROGRAM	\$486.00	
			086201236	LIVE ANSWERING SERVICE FOR TOW PROGRAM	\$516.45	
			086300429	LIVE ANSWERING SERVICE FOR TOW PROGRAM	\$511.50	

Item No. A.4

-75-



City of Moreno Valley
Payment Register
 For Period 12/1/2012 through 12/31/2012

CHECKS UNDER \$25,000

<u>Vendor Name</u>	<u>Check/EFT Number</u>	<u>Payment Date</u>	<u>Invoice Number</u>	<u>Invoice Description</u>	<u>Amount</u>	<u>FYTD</u>
				Remit to: RIVERSIDE, CA	\$1,513.95	\$2,957.40
PSOMAS	215375	12/17/2012	84352	CONSULTING SERVICES - NASON/CACTUS	\$1,435.00	
				Remit to: SANTA ANA, CA	\$1,435.00	\$22,161.00
QUALITY CODE PUBLISHING, LLC	8063	12/10/2012	2012-359	SUPPLEMENT SERVICE TO THE MV MUNICIPAL CODE	\$1,381.34	
				Remit to: SEATTLE, WA	\$1,381.34	\$3,116.63
RALPH NAVARRETTE	8110	12/10/2012	121201	RETIREE MED BENEFIT DEC '12	\$225.99	
				Remit to: RANCHO CUCAMONGA, CA	\$225.99	\$1,129.95
RBF CONSULTING, INC.	8150	12/17/2012	12090145	CONSULTING SERVICES - NASON/CACTUS	\$1,025.00	
				Remit to: IRVINE, CA	\$1,025.00	\$33,168.44
REBECCA S. GUILLAN	8085	12/10/2012	121201	RETIREE MED BENEFIT DEC '12, PD DEC '12	\$275.31	
				Remit to: ADVANCE, NC	\$275.31	\$1,376.55
REPUBLIC MASTER CHEFS	215268	12/10/2012	S180265	LINENS FOR SPECIAL EVENTS AT CRC	\$45.00	
			S180266	LINENS FOR SPECIAL EVENTS AT CRC	\$75.00	
			S180508	LINENS FOR SPECIAL EVENTS AT CRC	\$10.50	
			S182895	LINENS FOR SPECIAL EVENTS AT CRC	\$33.95	
			10803738	LINEN RENTAL FOR CRC	\$23.74	
			S182906	LINENS FOR SPECIAL EVENTS AT CRC	\$43.10	
			10816216	LINEN RENTAL FOR CRC	\$25.00	
			10829231	LINEN RENTAL FOR CRC	\$25.00	
			10822408	LINEN RENTAL FOR CRC	\$25.00	

-76-



City of Moreno Valley
Payment Register
 For Period 12/1/2012 through 12/31/2012

CHECKS UNDER \$25,000

<u>Vendor Name</u>	<u>Check/EFT Number</u>	<u>Payment Date</u>	<u>Invoice Number</u>	<u>Invoice Description</u>	<u>Amount</u>	<u>FYTD</u>
REPUBLIC MASTER CHEFS	215268	12/10/2012	10836372	LINEN RENTAL FOR CRC	\$25.00	
			S182905	LINENS FOR SPECIAL EVENTS AT CRC	\$91.30	
			Remit to: LOS ANGELES, CA		\$422.59	\$624.00
REPUBLIC MASTER CHEFS	215468	12/20/2012	S186834	LINENS FOR SPECIAL EVENTS AT CRC	\$65.75	
			S186837	LINENS FOR SPECIAL EVENTS AT CRC	\$69.95	
			10842548	LINEN RENTAL FOR CRC	\$24.78	
			S186838	LINENS FOR SPECIAL EVENTS AT CRC	\$41.00	
			Remit to: LOS ANGELES, CA		\$201.48	\$624.07
RICK ENGINEERING COMPANY	8151	12/17/2012	0029012	CONSULTING SERVICES, SURVEY - NASON/CACTUS	\$13,742.50	
			0029002	CONSULTING SERVICES, SURVEY - LOCAL STREET PAVEMENT RESURFACING	\$220.00	
Remit to: RIVERSIDE, CA		\$13,962.50	\$96,784.46			
RICK HARTMANN	215296	12/10/2012	121201	RETIREE MED BENEFIT DEC '12	\$318.73	
Remit to: SAN DIMAS, CA		\$318.73	\$956.19			
RIGHTWAY SITE SERVICES, INC.	215377	12/17/2012	717758	PORTABLE TOILET ON WHEELS/SERVICE FOR M&O DIV.	\$89.55	
Remit to: LAKE ELSINORE, CA		\$89.55	\$2,931.41			
RIVERSIDE CO. SHERIFF'S DEPT	215341	12/11/2012	JAN 7-11, 2013	REGISTR-INTERMD. TRAFFIC COLL. INV.- HACKWORTH, MURPHY, & YOUNG	\$597.00	
			JAN28-FEB8, 2013	REGISTR-ADVANCED TRAFFIC COLL. INVESTIG.-W. YOUNG	\$481.00	
Remit to: RIVERSIDE, CA		\$1,078.00	\$2,340.00			

Item No. A.4

-77-



City of Moreno Valley
Payment Register
 For Period 12/1/2012 through 12/31/2012

CHECKS UNDER \$25,000

<u>Vendor Name</u>	<u>Check/EFT Number</u>	<u>Payment Date</u>	<u>Invoice Number</u>	<u>Invoice Description</u>	<u>Amount</u>	<u>FYTD</u>
RIVERSIDE COUNTY BAR ASSOCIATION	215269	12/10/2012	2013 DUES STMT	MEMBERSHIP DUES FOR CITY ATTORNEY	\$120.00	
			Remit to:	RIVERSIDE, CA	\$120.00	\$120.00
RIVERSIDE COUNTY CLERK	215225	12/03/2012	112712-Fee	CA DEPT OF FISH AND GAME FEES - NOD FILING	\$2,165.50	
			Remit to:	RIVERSIDE, CA	\$2,165.50	\$2,165.50
RIVERSIDE COUNTY DEPARTMENT OF HEALTH	215211	12/03/2012	HS0000003875	RABIES TEST-ANIMAL SVCS	\$50.00	
			Remit to:	RIVERSIDE, CA	\$50.00	\$300.00
RIVERSIDE COUNTY FLOOD CONTROL & WATER CONSERVATION DIST.	215495	12/20/2012	RCFC-Fee121812	ENCROACHMENT PERMIT FEE DEPOSIT-NASON FROM CACTUS TO FIR	\$2,000.00	
			Remit to:	RIVERSIDE, CA	\$2,000.00	\$4,000.00
RIVERSIDE COUNTY INFORMATION TECHNOLOGY	215360	12/17/2012	9990170000-1209	VPN CONNECTION FOR CODE ENFORCEMENT	\$11.14	
			9990023000-1210	VPN CONNECTION FOR CODE ENFORCEMENT & HELP DESK SUPPORT	\$72.00	
			9990023000-1209	VPN CONNECTION FOR CODE ENFORCEMENT	\$17.70	
			9990170000-1210	VPN CONNECTION FOR CODE ENFORCEMENT	\$11.14	
			Remit to:	RIVERSIDE, CA	\$111.98	\$10,148.70
RIVERSIDE COUNTY INFORMATION TECHNOLOGY	215458	12/20/2012	9990085000-1210	RADIO COMM. SERVICES FOR PD MOTORCYCLES	\$983.50	
			Remit to:	RIVERSIDE, CA	\$983.50	\$10,148.70
RIVERSIDE COUNTY INFORMATION TECHNOLOGY (RCIT)	215378	12/17/2012	9990023000-1210	800-MHZ RADIO MONTHLY LEASE	\$189.90	

-78-



**City of Moreno Valley
Payment Register
For Period 12/1/2012 through 12/31/2012**

CHECKS UNDER \$25,000

<u>Vendor Name</u>	<u>Check/EFT Number</u>	<u>Payment Date</u>	<u>Invoice Number</u>	<u>Invoice Description</u>	<u>Amount</u>	<u>FYTD</u>
RIVERSIDE COUNTY INFORMATION TECHNOLOGY (RCIT)	215378	12/17/2012	9990023000-1209	800-MHZ RADIO MONTHLY LEASE	\$189.90	
			Remit to:	RIVERSIDE, CA	\$379.80	\$4,097.00
RIVERSIDE COUNTY SHERIFF	215317	12/10/2012	121129	GARNISHMENT	\$55.44	
			Remit to:	RIVERSIDE, CA	\$55.44	\$5,063.40
RIVERSIDE COUNTY SHERIFF	215400	12/17/2012	121215	GARNISHMENT	\$136.96	
			Remit to:	RIVERSIDE, CA	\$136.96	\$5,063.47
RMA GROUP, INC	215379	12/17/2012	41085	CONSULTING SERVICES, GEOTECHNICAL - CORPORATE YARD SEWER IMPRVMT	\$3,931.73	
			Remit to:	RANCHO CUCAMONGA, CA	\$3,931.73	\$3,931.73
ROBERT C. LUMLEY	8101	12/10/2012	121201	RETIREE MED BENEFIT DEC '12	\$318.73	
			Remit to:	MORENO VALLEY, CA	\$318.73	\$1,593.65
ROBERT D. HERRICK	215297	12/10/2012	121201	RETIREE MED BENEFIT DEC '12	\$318.73	
			Remit to:	MORENO VALLEY, CA	\$318.73	\$1,593.65
ROBERT GUTIERREZ	8086	12/10/2012	121201	RETIREE MED BENEFIT DEC '12	\$318.73	
			Remit to:	LA VERNE, CA	\$318.73	\$1,593.65
ROBERT H. WILLIS	215391	12/17/2012	111812	SPORTS OFFICIATING SERVICES	\$80.00	
			112512	SPORTS OFFICIATING SERVICES	\$60.00	
			Remit to:	PERRIS, CA	\$140.00	\$1,020.00
ROBERT MEYERS	215314	12/10/2012	OCT-2012	INSTRUCTOR SVCS-DRAWING FOR KIDS CLASS	\$189.00	
			Remit to:	MORENO VALLEY, CA	\$189.00	\$1,032.00

Item No. A.4

-79-



City of Moreno Valley
Payment Register
 For Period 12/1/2012 through 12/31/2012

CHECKS UNDER \$25,000

<u>Vendor Name</u>	<u>Check/EFT Number</u>	<u>Payment Date</u>	<u>Invoice Number</u>	<u>Invoice Description</u>	<u>Amount</u>	<u>FYTD</u>
ROBERT MILES	8105	12/10/2012	121201	RETIREE MED BENEFIT DEC '12	\$225.99	
			Remit to:	MORENO VALLEY, CA	\$225.99	\$1,129.95
ROBERT NELSON	8111	12/10/2012	121201	RETIREE MED BENEFIT DEC '12	\$320.43	
			Remit to:	ONTARIO, CA	\$320.43	\$1,602.15
ROBERTO RAMOS	215227	12/03/2012	NOV-2012	INSTRUCTOR SVCS-KINDER KARATE & TAE KWON DO CLASSES	\$330.60	
			Remit to:	MORENO VALLEY, CA	\$330.60	\$2,953.60
ROBERTO RAMOS	215408	12/17/2012	DEC-2012	INSTRUCTOR SVCS-KINDER KARATE & TAE KWON DO CLASSES	\$321.00	
			Remit to:	MORENO VALLEY, CA	\$321.00	\$2,953.60
RONALD A. WIELIN	8132	12/10/2012	121201	RETIREE MED BENEFIT DEC '12	\$318.73	
			Remit to:	BANNING, CA	\$318.73	\$1,593.65
ROSALYN CARTER	8076	12/10/2012	121201	RETIREE MED BENEFIT OCT-NOV '12, PD DEC '12	\$637.46	
			Remit to:	MORENO VALLEY, CA	\$637.46	\$1,593.65
ROSENOW SPEVACEK GROUP (RSG, INC.)	215270	12/10/2012	0028536	MV HOUSING AUTHORITY FY 11/12 ANNUAL REPORT PREPARATION SVCS	\$4,247.50	
			0028611	MV HOUSING AUTHORITY FY 11/12 ANNUAL REPORT PREPARATION SVCS	\$187.50	
			Remit to:	SANTA ANA, CA	\$4,435.00	\$9,233.98
ROSS W. HEFFLEY	8090	12/10/2012	121201	RETIREE MED BENEFIT DEC '12	\$318.73	
			Remit to:	HEMET, CA	\$318.73	\$1,593.65
RUTH L. NELSON	8112	12/10/2012	121201	RETIREE MED BENEFIT DEC '12	\$165.81	



**City of Moreno Valley
Payment Register
For Period 12/1/2012 through 12/31/2012**

CHECKS UNDER \$25,000

<u>Vendor Name</u>	<u>Check/EFT Number</u>	<u>Payment Date</u>	<u>Invoice Number</u>	<u>Invoice Description</u>	<u>Amount</u>	<u>FYTD</u>
				Remit to: PERRIS, CA	\$165.81	\$829.00
SA ASSOCIATES	8064	12/10/2012	74	CONSULTING SERVICES, ENGINEERING - NASON/CACTUS	\$10,087.50	
				Remit to: ARCADIA, CA	\$10,087.50	\$63,600.00
SARA L. ROCHA	8116	12/10/2012	121201	RETIREE MED BENEFIT OCT-NOV12 \$160X2, DEC12-FEB13 MEDI, PD DEC12	\$519.80	
				Remit to: QUEEN CREEK, AZ	\$519.80	\$1,399.40
SARA L. ROCHA	8211	12/20/2012	121201a	FEB'13 MEDI PD DEC'12	\$99.90	
				Remit to: QUEEN CREEK, AZ	\$99.90	\$1,399.40
SAT/HUMAN RESOURCES	8152	12/17/2012	WMN-7486	INTERACTIVE MEETING-A. WILSON	\$815.86	
				Remit to: CARSON, CA	\$815.86	\$815.86
SCMAF-INLAND VALLEYS	215344	12/11/2012	2012-28	SCMAF 2012 AWARDS & INSTALLATION	\$30.00	
			2012-26	SCMAF 2012 AWARDS & INSTALLATION	\$60.00	
			2012-27	SCMAF 2012 AWARDS & INSTALLATION	\$30.00	
				Remit to: CHINO HILLS, CA	\$120.00	\$120.00
SCOTT FAZEKAS & ASSOCIATES, INC	215272	12/10/2012	16364	PLAN CHECK SVCS FOR BLDG & SAFETY DEPT.	\$847.00	
				Remit to: IRVINE, CA	\$847.00	\$1,397.00
SEAN MALEK ENGINEERING AND CONSTRUCTION	215469	12/20/2012	07123-5	CONSTRUCTION CONTRACT - AUTO MALL IMPROVEMENTS	\$6,113.83	
				Remit to: TEMECULA, CA	\$6,113.83	\$205,809.29
SECTRAN SECURITY, INC	215380	12/17/2012	12120610 - CH	ARMORED TRANSPORT SVCS FOR CITY HALL CASHIER	\$159.00	

Item No. A.4

81-



City of Moreno Valley
Payment Register
 For Period 12/1/2012 through 12/31/2012

CHECKS UNDER \$25,000

<u>Vendor Name</u>	<u>Check/EFT Number</u>	<u>Payment Date</u>	<u>Invoice Number</u>	<u>Invoice Description</u>	<u>Amount</u>	<u>FYTD</u>
SECTRAN SECURITY, INC	215380	12/17/2012	12120610 - PR	ARMORED TRANSPORT SVCS FOR PARKS & COMM. SVCS	\$159.00	
			12120610 - ENT	ARMORED TRANSPORT SVCS FOR MV UTILITY	\$159.00	
			Remit to:	LOS ANGELES, CA	\$477.00	\$2,862.00
SECURITY LOCK & KEY	8027	12/03/2012	25620	RE-KEY GOLF COURSE TO PRIMUS SYSTEM	\$1,678.79	
			Remit to:	YUCAIPA, CA	\$1,678.79	\$3,078.23
SHARON K. SHARRETT	215306	12/10/2012	121201	RETIREE MED BENEFIT DEC '12	\$165.81	
			Remit to:	ONTARIO, CA	\$165.81	\$829.05
SHAW INDUSTRIES, INC.	215212	12/03/2012	7836829	CARPET SUPPLIES FOR 2ND FLOOR CITY HALL (STAIRS)	\$153.23	
			Remit to:	MENIFEE, CA	\$153.23	\$153.23
SHELL OIL CO.	215470	12/20/2012	065124489212	FUEL PURCHASES-PD MOTORCYCLES	\$1,547.56	
			Remit to:	COLUMBUS, OH	\$1,547.56	\$12,584.61
SHELL OIL CO.	215471	12/20/2012	079021622212	FUEL PURCHASES-PD SET	\$66.64	
			Remit to:	COLUMBUS, OH	\$66.64	\$12,584.61
SINGER & COFFIN	8205	12/20/2012	2803	PROFESSIONAL LEGAL SERVICES	\$1,646.70	
			Remit to:	IRVINE, CA	\$1,646.70	\$18,041.50
SKY PUBLISHING	215273	12/10/2012	12_7_103	PRINTING OF SOARING RECREATION GUIDE FOR WINTER/SPRING 2013	\$11,833.50	
			Remit to:	MORENO VALLEY, CA	\$11,833.50	\$11,833.50
SO CAL FPO	215347	12/11/2012	JAN. 15-16, 2013	REGISTR. FEE FOR CARLOS RODRIGUEZ FOR STATUTES & REGS. TRAINING	\$100.00	



**City of Moreno Valley
Payment Register
For Period 12/1/2012 through 12/31/2012**

CHECKS UNDER \$25,000

<u>Vendor Name</u>	<u>Check/EFT Number</u>	<u>Payment Date</u>	<u>Invoice Number</u>	<u>Invoice Description</u>	<u>Amount</u>	<u>FYTD</u>
				Remit to: SAN DIEGO, CA	\$100.00	\$100.00
SOCAL FPO	215411	12/17/2012	REG-P VILLALOBOS	REGISTRATION FEE-STATUTES & REGULATIONS TRNG ON FEB. 5-6, 2013	\$100.00	
			REG-F. MARTINEZ	REGISTRATION FEE-STATUTES & REGULATIONS TRNG ON FEB. 5-6, 2013	\$100.00	
				Remit to: ANAHEIM, CA	\$200.00	\$200.00
SOCO GROUP, INC	8154	12/17/2012	680769	FUEL FOR CITY VEHICLES & EQUIPMENT	\$7,175.50	
			681254	FUEL FOR CITY VEHICLES & EQUIPMENT	\$6,744.58	
			682284	FUEL FOR CITY VEHICLES & EQUIPMENT	\$6,957.45	
				Remit to: PERRIS, CA	\$20,877.53	\$148,351.12
SOUTH COAST AQMD	215472	12/20/2012	2531987	ANNUAL OPERATING FEES-DIESEL GENERATOR AT ANIMAL SHELTER	\$310.85	
			2533102	ANNUAL EMISSIONS FEES-DIESEL GENERATOR AT ANIMAL SHELTER	\$115.56	
				Remit to: DIAMOND BAR, CA	\$426.41	\$1,699.93
SOUTHERN CALIFORNIA EDISON	215213	12/03/2012	NOV-12 12/3/12	ELECTRICITY	\$3,527.97	
				Remit to: RIALTO, CA	\$3,527.97	\$67,207.91
SOUTHERN CALIFORNIA EDISON	215275	12/10/2012	OCT-12 12/10/12	ELECTRICITY	\$25.19	
			NOV-12 12/10/12	ELECTRICITY	\$5,406.07	
				Remit to: ROSEMEAD, CA	\$5,431.26	\$1,143,324.31
SOUTHERN CALIFORNIA EDISON	215474	12/20/2012	7500227371	RELIABILITY SERVICE-DLAP_SCE_SEES_HV	\$305.89	
			7500226417	WDAT CHARGES-SUBSTATION 115KV INTERCONNECTION	\$16,794.83	

Item No. A.4

-83-



City of Moreno Valley
Payment Register
 For Period 12/1/2012 through 12/31/2012

CHECKS UNDER \$25,000

<u>Vendor Name</u>	<u>Check/EFT Number</u>	<u>Payment Date</u>	<u>Invoice Number</u>	<u>Invoice Description</u>	<u>Amount</u>	<u>FYTD</u>
				Remit to: ROSEMEAD, CA	\$17,100.72	\$231,553.58
SOUTHERN CALIFORNIA FPO'S	215410	12/17/2012	NEW MEMBER APPS	MEMBERSHIP FEES FOR: C. RODRIGUEZ, F. MARTINEZ, & P. VILLALOBOS	\$195.00	
				Remit to: RANCHO CUCAMONGA, CA	\$195.00	\$195.00
SOUTHERN CALIFORNIA GAS CO.	215383	12/17/2012	NOV-2012	GAS CHARGES	\$5,581.26	
				Remit to: MONTEREY PARK, CA	\$5,581.26	\$21,100.47
SPARKLETTS	215277	12/10/2012	7364551 112312	BOTTLED WATER/SVC-SUNNYMEAD ELEMENTARY "A CHILD'S PLACE"	\$10.59	
			10050036 110212	BOTTLED WATER/SVC-EOC/ERF	\$35.19	
				Remit to: DALLAS, TX	\$45.78	\$466.65
SPARKLETTS	215475	12/20/2012	7363683 120212	BOTTLED WATER/SVC-ARMADA ELEMENTARY "A CHILD'S PLACE"	\$16.41	
			7364596 120212	BOTTLED WATER/SVC-CREEKSIDE ELEMENTARY "A CHILD'S PLACE"	\$11.84	
				Remit to: DALLAS, TX	\$28.25	\$466.65
SPRINT	215278	12/10/2012	LCI-154987	CELLULAR TECH EXTRACTION/LOCATOR SVCS	\$30.00	
			LCI-156152	CELLULAR TECH EXTRACTION/LOCATOR SVCS	\$30.00	
			LCI-155460	CELLULAR TECH EXTRACTION/LOCATOR SVCS	\$30.00	
			LCI-155408	CELLULAR TECH EXTRACTION/LOCATOR SVCS	\$40.00	
				Remit to: KANSAS CITY, MO	\$130.00	\$220.00
SPRINT	215476	12/20/2012	LCI-156953	CELLULAR TECH EXTRACTION/LOCATOR SVCS	\$30.00	
				Remit to: KANSAS CITY, MO	\$30.00	\$220.00



City of Moreno Valley
Payment Register
 For Period 12/1/2012 through 12/31/2012

CHECKS UNDER \$25,000

<u>Vendor Name</u>	<u>Check/EFT Number</u>	<u>Payment Date</u>	<u>Invoice Number</u>	<u>Invoice Description</u>	<u>Amount</u>	<u>FYTD</u>
SPRINT/NEXTEL COMMUNICATIONS	8065	12/10/2012	417544340-072	CELLULAR PHONE SVC FOR PD GTF	\$77.12	
			634235346-026	CELLULAR PHONE SVC FOR PD SET (SHORT-PAID PENDING CASE 7391885)	\$650.00	
				Remit to: CAROL STREAM, IL	\$727.12	\$4,291.33
SPRINT/NEXTEL COMMUNICATIONS	8206	12/20/2012	634235346-027	CELLULAR PHONE SVC FOR PD SET (SHORT-PAID PENDING CASE 7391885)	\$650.00	
				Remit to: CAROL STREAM, IL	\$650.00	\$4,291.33
STAN BUCKINGHAM	215291	12/10/2012	121201	RETIREE MED BENEFIT DEC '12	\$318.73	
				Remit to: TEMECULA, CA	\$318.73	\$1,593.65
STANDARD INSURANCE CO	215229	12/03/2012	121201	SUPPLEMENTAL INSURANCE	\$1,788.79	
				Remit to: PORTLAND, OR	\$1,788.79	\$8,918.85
STANLEY CONVERGENT SECURITY	8155	12/17/2012	9737678	COMBINE TWO EXISTING INTRUSION ALARMS AT GOLF COURSE	\$1,826.00	
				Remit to: PALATINE, IL	\$1,826.00	\$13,767.46
STATE BAR OF CALIFORNIA	215384	12/17/2012	207114 - YR 2013	2013 MEMBER FEES & MCLE COMPLIANCE-S. BRYANT	\$410.00	
			130677 - YR 2013	2013 MEMBER FEES & MCLE COMPLIANCE-R. HANSEN	\$410.00	
			216785 - YR 2013	2013 MEMBER FEES & MCLE COMPLIANCE-P. EARLY	\$410.00	
				Remit to: LOS ANGELES, CA	\$1,230.00	\$1,230.00
STATE BOARD OF EQUALIZATION	8223	12/21/2012	113012	SALES & USE TAX REPORT 11/1-11/30/12	\$1,452.00	
				Remit to: SACRAMENTO, CA	\$1,452.00	\$13,763.00

Item No. A.4

85-



City of Moreno Valley
Payment Register
 For Period 12/1/2012 through 12/31/2012

CHECKS UNDER \$25,000

<u>Vendor Name</u>	<u>Check/EFT Number</u>	<u>Payment Date</u>	<u>Invoice Number</u>	<u>Invoice Description</u>	<u>Amount</u>	<u>FYTD</u>
STATE DISBURSEMENT UNIT	8177	12/13/2012	CS121213	3201-CHILD SUPPORT WITHHOLDING	\$2,172.42	
			Remit to:	WEST SACRAMENTO, CA	\$2,172.42	\$30,752.14
STATE DISBURSEMENT UNIT	8299	12/27/2012	CS121227	3209-CHILD SUPPORT WITHHOLDING	\$2,278.35	
			Remit to:	WEST SACRAMENTO, CA	\$2,278.35	\$30,752.14
STENO SOLUTIONS TRANSCRIPTION SVCS., IN	215477	12/20/2012	42456	TRANSCRIPTION SERVICES FOR PD	\$2,747.20	
			Remit to:	CORONA, CA	\$2,747.20	\$22,151.52
STEVE CHAPMAN	215292	12/10/2012	121201	RETIREE MED BENEFIT DEC '12	\$318.73	
			Remit to:	REDLANDS, CA	\$318.73	\$1,593.65
STEVE KUPSAK	8094	12/10/2012	121201	RETIREE MED BENEFIT SEP-NOV '12, PD DEC '12	\$956.19	
			Remit to:	CEDAR GLEN, CA	\$956.19	\$1,912.38
STI, INC. and ORCO BLOCK CO.	215415	12/17/2012	11-901-Ret-3	JOINT CHECK-IRONWOOD AVE IMPROVEMENTS PROJECT RETENTION RELEASE	\$9,095.71	
			Remit to:	RIVERSIDE, CA	\$9,095.71	\$9,095.71
STI, INC. and S&J CONCRETE PUMPING, INC.	215414	12/17/2012	11-901-Ret-2	JOINT CHECK-IRONWOOD AVE IMPROVEMENTS PROJECT RETENTION RELEASE	\$1,269.00	
			Remit to:	RIVERSIDE, CA	\$1,269.00	\$1,269.00
STUART H. SHELDON	215307	12/10/2012	121201	RETIREE MED BENEFIT DEC '12	\$318.73	
			Remit to:	MURRIETA, CA	\$318.73	\$1,593.65
SUE A. MAXINOSKI	8103	12/10/2012	121201	RETIREE MED BENEFIT DEC '12	\$318.73	



**City of Moreno Valley
Payment Register
For Period 12/1/2012 through 12/31/2012**

CHECKS UNDER \$25,000

<u>Vendor Name</u>	<u>Check/EFT Number</u>	<u>Payment Date</u>	<u>Invoice Number</u>	<u>Invoice Description</u>	<u>Amount</u>	<u>FYTD</u>
				Remit to: AVINGER, TX	\$318.73	\$1,593.6
SUNNYMEAD ACE HARDWARE	215215	12/03/2012	49109	MISC. SUPPLIES/TOOLS FOR FIRE STATION 99	\$113.13	
			49198	MISC. SUPPLIES/TOOLS FOR FIRE STATION 99	\$118.69	
				Remit to: MORENO VALLEY, CA	\$231.82	\$514.2
SUNNYMEAD ACE HARDWARE	215280	12/10/2012	49528	MISC. SUPPLIES FOR PD	\$38.83	
			49356	MISC. SUPPLIES FOR PD	\$27.89	
			49083	MISC. SUPPLIES FOR PD	\$8.60	
			48812	MISC. SUPPLIES FOR PD	\$83.17	
			48909	MISC. SUPPLIES FOR PD	\$11.54	
			48818	MISC. SUPPLIES FOR PD	\$10.01	
			48484	MISC. SUPPLIES FOR PD	\$15.28	
				Remit to: MORENO VALLEY, CA	\$195.32	\$337.34
SUSAN A. JONES	8091	12/10/2012	121201	RETIREE MED BENEFIT DEC '12	\$318.73	
				Remit to: MORENO VALLEY, CA	\$318.73	\$1,593.65
SUSAN A. SLAGERMAN	8122	12/10/2012	121201	RETIREE MED BENEFIT OCT-NOV '12, PD DEC '12	\$637.46	
				Remit to: MORENO VALLEY, CA	\$637.46	\$1,593.65
TARA TRICHE	215418	12/17/2012	DEC-2012	INSTRUCTOR SVCS-DANCE CLASSES	\$1,998.00	
				Remit to: MORENO VALLEY, CA	\$1,998.00	\$12,638.40
TAX COMPLIANCE SERVICES	215478	12/20/2012	2012-2013 STMT 5	UUT AUDIT & CONSULTING SVCS	\$5,000.00	
				Remit to: THOUSAND OAKS, CA	\$5,000.00	\$30,000.00

Item No. A.4

-87-



City of Moreno Valley
Payment Register
 For Period 12/1/2012 through 12/31/2012

CHECKS UNDER \$25,000

<u>Vendor Name</u>	<u>Check/EFT Number</u>	<u>Payment Date</u>	<u>Invoice Number</u>	<u>Invoice Description</u>	<u>Amount</u>	<u>FYTD</u>
TERRY L. STREICH	215308	12/10/2012	121201	RETIREE MED BENEFIT VSP DEC 12, PD DEC 12	\$30.33	
			Remit to:	MORENO VALLEY, CA	\$30.33	\$1,367.80
THE COUNSELING TEAM	215198	12/03/2012	20452	EMPLOYEE SUPPORT SVCS	\$1,250.00	
			Remit to:	SAN BERNARDINO, CA	\$1,250.00	\$8,750.00
THE LEW EDWARDS GROUP	215281	12/10/2012	001	REVENUE MEASURE FEASIBILITY STUDY-AUG12	\$7,152.60	
			Remit to:	OAKLAND, CA	\$7,152.60	\$7,152.60
THE ROTARY CLUB OF MORENO VALLEY	215479	12/20/2012	DONATION	DONATION FROM COUNCIL MBR MOLINA FOR FOOD FOR THANKSGIVING FEAST	\$100.00	
			Remit to:	MORENO VALLEY, CA	\$100.00	\$100.00
THEODORE J. BECKWITH	215282	12/10/2012	12-005	EXPERT WITNESS SVC-MV1208	\$325.00	
			Remit to:	RIVERSIDE, CA	\$325.00	\$325.00
THERMAL COMBUSTION INNOVATORS	215216	12/03/2012	94281	BIOHAZARD MEDICAL WASTE DISPOSAL SVCS FOR ANIMAL SHELTER	\$70.95	
			97791	BIOHAZARD MEDICAL WASTE DISPOSAL SVCS FOR ANIMAL SHELTER	\$71.34	
			94224	BIOHAZARD MEDICAL WASTE DISPOSAL SVCS FOR ANIMAL SHELTER	\$70.88	
			97633	BIOHAZARD MEDICAL WASTE DISPOSAL SVCS FOR ANIMAL SHELTER	\$86.31	
			97734	BIOHAZARD MEDICAL WASTE DISPOSAL SVCS FOR ANIMAL SHELTER	\$71.26	
			Remit to:	COLTON, CA	\$370.74	\$583.86
THOMPSON COBURN LLP	8066	12/10/2012	2500209	LEGAL SVCS FOR MVU	\$316.22	



**City of Moreno Valley
Payment Register
For Period 12/1/2012 through 12/31/2012**

CHECKS UNDER \$25,000

<u>Vendor Name</u>	<u>Check/EFT Number</u>	<u>Payment Date</u>	<u>Invoice Number</u>	<u>Invoice Description</u>	<u>Amount</u>	<u>FYTD</u>
				Remit to: WASHINGTON, DC	\$316.22	\$7,336.9
THOMPSON COBURN LLP	8207	12/20/2012	2503229	LEGAL SVCS FOR MVU	\$234.50	
				Remit to: WASHINGTON, DC	\$234.50	\$7,336.9
THOMSON REUTERS	215223	12/03/2012	825861048	LEGAL PUBLICATIONS UPDATES SUBSCRIPTIONS	\$638.97	
			826047667	LEGAL PUBLICATIONS UPDATES SUBSCRIPTIONS	\$116.38	
				Remit to: CAROL STREAM, IL	\$755.35	\$1,609.17
TOM TUCKER dba SCCS	8026	12/03/2012	10112	CONSULTING SVCS-CITYWIDE CAMERA SURVEILLANCE SYSTEM	\$3,806.30	
				Remit to: CLOVIS, CA	\$3,806.30	\$12,047.00
TRENT D. PULLIAM	8115	12/10/2012	121201	RETIREE MED BENEFIT DEC '12	\$318.73	
				Remit to: MISSION VIEJO, CA	\$318.73	\$1,593.65
TROPICAL PLAZA NURSERY, INC.	215218	12/03/2012	M51047	TREE TRIMMING/CLEANUP THROUGHOUT PASEO AREA OF ZONE E-2	\$5,800.00	
			M50960	LANDSCAPE MAINT-ZONE E-2	\$6,101.66	
				Remit to: VILLA PARK, CA	\$11,901.66	\$60,195.22
TRUGREEN LANDCARE	8029	12/03/2012	7409738	RETAKE 25 TREES ALONG VIA DEL LAGO	\$224.02	
			7390551B	LANDSCAPE MAINT-ZONE S	\$914.65	
			7359892B	LANDSCAPE MAINT-ZONE S	\$914.65	
			7409726	OVERSEED OF TURF AREA ALONG MORENO BEACH & VIA DEL LAGO	\$360.00	
			7375658B	LANDSCAPE MAINT-ZONE S	\$914.65	

Item No. A.4

-89-



**City of Moreno Valley
Payment Register
For Period 12/1/2012 through 12/31/2012**

CHECKS UNDER \$25,000

<u>Vendor Name</u>	<u>Check/EFT Number</u>	<u>Payment Date</u>	<u>Invoice Number</u>	<u>Invoice Description</u>	<u>Amount</u>	<u>FYTD</u>
				Remit to: RIVERSIDE, CA	\$3,327.97	\$130,154.03
TRUGREEN LANDCARE	8067	12/10/2012	7422525	LANDSCAPE MAINT-ZONE S	\$914.65	
			7422524	LANDSCAPE MAINT-ZONE E-4 & E-4A	\$8,445.86	
			7422522	LANDSCAPE MAINT-ZONE E-16	\$2,485.00	
			7422521	LANDSCAPE MAINT-ZONE DSG-1	\$5,121.57	
			7422520	LANDSCAPE MAINT-ZONE M	\$4,955.00	
			7425054	TRACT #19032-TRIM SHRUBS, CUT WEEDS, SPRAY WITH ROUND-UP	\$850.00	
			7424938	IRRIGATION REPAIRS-ZONE E-4	\$450.55	
				Remit to: RIVERSIDE, CA	\$23,222.63	\$130,154.03
TRUGREEN LANDCARE	8208	12/20/2012	7426705	STUMP REMOVED & 24" BOX TREE INSTALLED AT CITY HALL	\$330.00	
				Remit to: RIVERSIDE, CA	\$330.00	\$130,154.03
TURF STAR, INC.	215480	12/20/2012	2270598-00	PARTS FOR GOLF COURSE EQUIPMENT MAINT/REPAIRS	\$2,511.38	
				Remit to: SAN FRANCISCO, CA	\$2,511.38	\$12,196.49
TW TELECOM	215219	12/03/2012	05166888	TELECOM SVCS-LOCAL/LONG DISTANCE CALLS	\$1,523.09	
			05166888a	INTERNET & DATA SVCS	\$1,549.31	
				Remit to: DENVER, CO	\$3,072.40	\$21,430.16
TW TELECOM	215481	12/20/2012	05222362a	INTERNET & DATA SVCS	\$1,549.31	
			05222362	TELECOM SVCS-LOCAL/LONG DISTANCE CALLS	\$1,469.39	



**City of Moreno Valley
Payment Register
For Period 12/1/2012 through 12/31/2012**

CHECKS UNDER \$25,000

<u>Vendor Name</u>	<u>Check/EFT Number</u>	<u>Payment Date</u>	<u>Invoice Number</u>	<u>Invoice Description</u>	<u>Amount</u>	<u>FYTD</u>
				Remit to: DENVER, CO	\$3,018.70	\$21,430.1
U.S. HEALTHWORKS MEDICAL GROUP	215220	12/03/2012	122116424 10/10	EMPLOYEE MEDICAL TREATMENT/CARE COORDINATION	\$159.04	
			2186758-CA	EMPLOYEE DOT PHYSICAL EXAM	\$65.00	
				Remit to: LOS ANGELES, CA	\$224.04	\$2,221.9
U.S. HEALTHWORKS MEDICAL GROUP	215283	12/10/2012	122116905 11/06	EMPLOYEE INJURY MEDICAL TREATMENT/CARE	\$103.86	
				Remit to: LOS ANGELES, CA	\$103.86	\$2,221.98
U.S. HEALTHWORKS MEDICAL GROUP	215482	12/20/2012	130066046 11/13	EMPLOYEE INJURY MEDICAL TREATMENT/CARE	\$230.01	
			130066046 11/20	EMPLOYEE INJURY MEDICAL TREATMENT/CARE	\$68.62	
			130066046 11/12	EMPLOYEE INJURY MEDICAL TREATMENT/CARE	\$113.34	
				Remit to: LOS ANGELES, CA	\$411.97	\$2,221.98
U.S. TREASURY	8220	12/20/2012	W121205	INITIAL PAYMENT PURSUANT TO HUD REQUEST	\$12,147.00	
				Remit to: WASHINGTON, DC	\$12,147.00	\$12,147.00
UNDERGROUND SERVICE ALERT	8209	12/20/2012	1120120434c	DIGALERT TICKETS SUBSCRIPTION SERVICE	\$93.00	
			1120120434d	DIGALERT TICKETS SUBSCRIPTION SERVICE	\$93.00	
			1120120434a	DIGALERT TICKETS SUBSCRIPTION SERVICE	\$93.00	
			1120120434b	DIGALERT TICKETS SUBSCRIPTION SERVICE	\$93.00	
				Remit to: CORONA, CA	\$372.00	\$2,571.00
UNION BANK OF CALIFORNIA NA	215284	12/10/2012	782358	INVESTMENT SAFEKEEPING SERVICES	\$291.67	

Item No. A.4

-91-



City of Moreno Valley
Payment Register
 For Period 12/1/2012 through 12/31/2012

CHECKS UNDER \$25,000

<u>Vendor Name</u>	<u>Check/EFT Number</u>	<u>Payment Date</u>	<u>Invoice Number</u>	<u>Invoice Description</u>	<u>Amount</u>	<u>FYTD</u>
				Remit to: SAN DIEGO, CA	\$291.67	\$909.34
UNITED ROTARY BRUSH CORP.	8156	12/17/2012	273682	STREET SWEEPER BROOM KITS/RECONDITIONING	\$1,266.16	
				Remit to: ESCONDIDO, CA	\$1,266.16	\$10,833.42
UNITED SITE SERVICES OF CA, INC.	8030	12/03/2012	114-934546	FENCE RENTAL AT ANIMAL SHELTER	\$106.40	
				Remit to: EL MONTE, CA	\$106.40	\$319.20
UNITED WAY OF INLAND VALLEYS	215318	12/10/2012	121129	U W CONTRIBUTIONS	\$335.00	
				Remit to: RIVERSIDE, CA	\$335.00	\$4,020.00
UNITED WAY OF INLAND VALLEYS	215402	12/17/2012	121215	U W CONTRIBUTIONS	\$335.00	
				Remit to: RIVERSIDE, CA	\$335.00	\$4,020.00
USA MOBILITY/ARCH WIRELESS	8157	12/17/2012	V6218870L	PAGER SERVICE	\$35.80	
				Remit to: SPRINGFIELD, VA	\$35.80	\$213.64
VA CONSULTING, INC.	8068	12/10/2012	30737	CONSULTING SERVICES, DESIGN - AUTO MALL	\$389.58	
				Remit to: IRVINE, CA	\$389.58	\$2,997.89
VACATE TERMITE & PEST ELIMINATION CO.	8031	12/03/2012	28434	PEST CONTROL SERVICE-FIRE STATION #6	\$45.00	
			28456	PEST CONTROL SERVICE-FIRE STATION #58	\$45.00	
			28431	PEST CONTROL SERVICE-FIRE STATION #65	\$45.00	
			28432	PEST CONTROL SERVICE-TOWNGATE COMM. CTR	\$45.00	
			28435	PEST CONTROL SERVICE-LIBRARY	\$55.00	

-92-



City of Moreno Valley
Payment Register
 For Period 12/1/2012 through 12/31/2012

CHECKS UNDER \$25,000

<u>Vendor Name</u>	<u>Check/EFT Number</u>	<u>Payment Date</u>	<u>Invoice Number</u>	<u>Invoice Description</u>	<u>Amount</u>	<u>FYTD</u>
VACATE TERMITE & PEST ELIMINATION CO.	8031	12/03/2012	28454	PEST CONTROL SERVICE-UTILITY FIELD OFFICE	\$45.00	
			28457	PEST CONTROL SERVICE-SENIOR CTR	\$55.00	
			28458	PEST CONTROL SERVICE-FIRE STATION #2	\$45.00	
			28459	PEST CONTROL SERVICE-FIRE STATION #91	\$45.00	
			28588	PEST CONTROL SERVICE-GOLF COURSE PRO SHOP	\$45.00	
			28589	PEST CONTROL SERVICE-EOC	\$55.00	
			28590	PEST CONTROL SERVICE-CITY HALL	\$75.00	
			28601	PEST CONTROL SERVICE-MARCH FIELD BLDG 823	\$45.00	
			28603	PEST CONTROL SERVICE-TRANSP. TRAILER	\$45.00	
			28453	PEST CONTROL SERVICE-FIRE STATION #48	\$45.00	
			28591	PEST CONTROL SERVICE-CONFERENCE & REC CTR	\$75.00	
			28602	PEST CONTROL SERVICE-MARCH FIELD PARK COMM. CTR	\$45.00	
			28599	PEST CONTROL SERVICE-ANIMAL SHELTER	\$115.00	
			28598	PEST CONTROL SERVICE-ANNEX BLDG 1	\$55.00	
			28593	PEST CONTROL SERVICE-PUBLIC SAFETY BLDG	\$75.00	
			28592	PEST CONTROL SERVICE-CITY YARD	\$115.00	
				Remit to: MORENO VALLEY, CA	\$1,215.00	\$6,985.00
VARIABLE SPEEDS SOLUTIONS INC	215221	12/03/2012	8559	IRRIGATION PUMP MAINTENANCE-NPDES AREAS	\$190.00	

Item No. A.4

-93-



**City of Moreno Valley
Payment Register
For Period 12/1/2012 through 12/31/2012**

CHECKS UNDER \$25,000

<u>Vendor Name</u>	<u>Check/EFT Number</u>	<u>Payment Date</u>	<u>Invoice Number</u>	<u>Invoice Description</u>	<u>Amount</u>	<u>FYTD</u>
VARIABLE SPEEDS SOLUTIONS INC	215221	12/03/2012	8561	IRRIGATION PUMP MAINTENANCE-NPDES AREAS	\$190.00	
			Remit to:	HUNTINGTON BEACH, CA	\$380.00	\$3,230.00
VAS ASSOCIATES, INC.	8158	12/17/2012	173	CONSULTING SERVICES, ENGINEERING - NASON/CACTUS	\$18,720.00	
			Remit to:	CORONA, CA	\$18,720.00	\$135,360.00
VAVRINEK, TRINE, DAY & CO., LLP	215285	12/10/2012	0092878-IN	CONSULTING SVCS-ASSISTANCE WITH DEVELOPER DEPOSITS & BALANCES	\$540.00	
			Remit to:	RANCHO CUCAMONGA, CA	\$540.00	\$17,190.00
VERIZON	215388	12/17/2012	EQN6913105-12333	BACKBONE COMMUNICATION CHARGES	\$1,775.70	
			Remit to:	TRENTON, NJ	\$1,775.70	\$10,574.13
VERIZON CALIFORNIA	215483	12/20/2012	1258220327DEC-12	FIOS SERVICES FOR FIRE STATION 99	\$182.10	
			Remit to:	DALLAS, TX	\$182.10	\$4,547.96
VERIZON CALIFORNIA	215484	12/20/2012	951 UH2-7052/DEC	PHONE CHARGES-ERC	\$623.89	
			Remit to:	DALLAS, TX	\$623.89	\$4,547.96
VERIZON WIRELESS	215286	12/10/2012	1136266053	CELLULAR SERVICE FOR PD TICKET WRITERS	\$169.05	
			Remit to:	DALLAS, TX	\$169.05	\$843.90
VERTEX, INC.	8159	12/17/2012	4089233	PAYROLL TAX Q SERIES SOLUTION SVC AGREEMENT 12/1/12-11/30/13	\$845.84	
			Remit to:	BERWYN, PA	\$845.84	\$1,635.12
VISION SERVICE PLAN	8160	12/17/2012	121201	EMPLOYEE VISION INSURANCE	\$3,978.54	
			Remit to:	SAN FRANCISCO, CA	\$3,978.54	\$23,499.30

-94



**City of Moreno Valley
Payment Register
For Period 12/1/2012 through 12/31/2012**

CHECKS UNDER \$25,000

<u>Vendor Name</u>	<u>Check/EFT Number</u>	<u>Payment Date</u>	<u>Invoice Number</u>	<u>Invoice Description</u>	<u>Amount</u>	<u>FYTD</u>
VISTA PAINT CORPORATION	215222	12/03/2012	2012-422178-00	TRAFFIC PAINT	\$1,215.89	
			2012-421841-00	TRAFFIC PAINTING SUPPLIES	\$2,090.35	
			2012-421852-00	TRAFFIC PAINT	\$607.95	
			Remit to: FULLERTON, CA			
VOYAGER FLEET SYSTEM, INC.	8161	12/17/2012	869211615247	CNG FUEL PURCHASES	\$1,486.80	
			Remit to: HOUSTON, TX		\$1,486.80	\$9,297.83
VULCAN MATERIALS COMPANY	215389	12/17/2012	217912	ASPHALTIC MATERIALS	\$111.33	
			223579	ASPHALTIC MATERIALS	\$109.19	
			223580	ASPHALTIC MATERIALS	\$146.17	
			221873	ASPHALTIC MATERIALS	\$109.19	
			219166	ASPHALTIC MATERIALS	\$110.62	
			212897	ASPHALTIC MATERIALS	\$434.60	
			212896	ASPHALTIC MATERIALS	\$110.62	
			209581	ASPHALTIC MATERIALS	\$110.62	
			209580	ASPHALTIC MATERIALS	\$109.19	
			205993	ASPHALTIC MATERIALS	\$110.62	
			205992	ASPHALTIC MATERIALS	\$75.05	
215613	ASPHALTIC MATERIALS	\$109.91				
			Remit to: LOS ANGELES, CA		\$1,647.11	\$9,049.26
WELLS FARGO BANK	215287	12/10/2012	905281	TRUSTEE FEES 11/29/12-11/28/13 FOR CFD 87-1 2007 SPEC TAX REF BD	\$2,000.00	

Item No. A.4

-95-



**City of Moreno Valley
Payment Register
For Period 12/1/2012 through 12/31/2012**

CHECKS UNDER \$25,000

<u>Vendor Name</u>	<u>Check/EFT Number</u>	<u>Payment Date</u>	<u>Invoice Number</u>	<u>Invoice Description</u>	<u>Amount</u>	<u>FYTD</u>
WELLS FARGO BANK	215287	12/10/2012	905282	TRUSTEE FEES 11/29/12-11/28/13 FOR CFD 87-1 IMP AREA #1 REF BD	\$2,000.00	
			Remit to:	MINNEAPOLIS, MN	\$4,000.00	\$4,000.00
WEST COAST ARBORISTS, INC.	8069	12/10/2012	84228	TREE TRIMMING & REMOVAL SERVICES- ZONE E-3	\$2,765.00	
			Remit to:	ANAHEIM, CA	\$2,765.00	\$6,285.00
WESTERN MUNICIPAL WATER DISTRICT	215485	12/20/2012	24753-018620/NOV	WATER CHARGES-MARB BALLFIELDS	\$377.80	
			23821-018258/NOV	WATER CHARGES-MFPCC BLDG 938	\$70.00	
			23866-018292/NOV	WATER CHARGES-SKATE PARK	\$19.10	
			23821-018257/NOV	WATER CHARGES-MFPCC LANDSCAPE	\$427.84	
			Remit to:	ARTESIA, CA	\$894.74	\$13,317.67
WESTERN PACIFIC SIGNAL, LLC	215486	12/20/2012	16753	AUDIBLE PEDESTRIAN SIGNAL DEVICE	\$6,107.02	
			Remit to:	SAN LEANDRO, CA	\$6,107.02	\$6,107.02
WESTERN RIVERSIDE CO. OF GOVT'S	215392	12/17/2012	1212041	DAY ST ROADWAY IMPROVEMENTS ASSESEMNT	\$9.81	
			NOV-12 TUMF	TUMF FEES COLLECTED FOR 11/1-11/30/12	\$18,263.09	
			Remit to:	RIVERSIDE, CA	\$18,272.90	\$621,274.14
WFCA: THE DAILY DISPATCH	215419	12/17/2012	2785	STATE-WIDE EMPLOYMENT AD FOR FIRE SAFETY SPECIALIST	\$225.00	
			Remit to:	SALEM, OR	\$225.00	\$225.00
WILLDAN ENGINEERING	215390	12/17/2012	00314254	CONSULTING SERVICES - PAVEMENT MGMT PGM.	\$4,473.75	
			00314441	CONSULTING SERVICES - PAVEMENT MGMT. PJT.	\$15,091.25	

-96-



City of Moreno Valley
Payment Register
 For Period 12/1/2012 through 12/31/2012

CHECKS UNDER \$25,000

<u>Vendor Name</u>	<u>Check/EFT Number</u>	<u>Payment Date</u>	<u>Invoice Number</u>	<u>Invoice Description</u>	<u>Amount</u>	<u>FYTD</u>
				Remit to: SAN BERNARDINO, CA	\$19,565.00	\$61,263.2
WILLIAM R. HAMLIN	8087	12/10/2012	121201	RETIREE MED BENEFIT DEC '12	\$318.73	
				Remit to: BEAUMONT, CA	\$318.73	\$1,593.6
WURM'S JANITORIAL SERVICES, INC.	8032	12/03/2012	21059	JANITORIAL SVCS-SUNNYMEAD MIDDLE SCHOOL-ASES	\$152.10	
				Remit to: CORONA, CA	\$152.10	\$139,972.23
WURM'S JANITORIAL SERVICES, INC.	8162	12/17/2012	21768	JANITORIAL SVCS-EOC	\$688.36	
			21759	JANITORIAL SVCS-SENIOR CENTER	\$1,916.18	
			21764	JANITORIAL SVCS-LIBRARY	\$1,771.79	
			21763	JANITORIAL SVCS-MARCH FIELD PARK COMM. CTR	\$955.70	
			21762	JANITORIAL SVCS-PUBLIC SAFETY BLDG	\$5,564.25	
			21786	SPECIAL CLEANINGS FOR EVENT RENTALS AT CRC	\$1,800.00	
			21765	JANITORIAL SVCS-FACILITIES ANNEX	\$124.29	
			21755	JANITORIAL SVCS-TS ANNEX	\$453.43	
			21769	JANITORIAL SVCS-CONFERENCE CTR	\$3,447.93	
			21770	JANITORIAL SVCS-CITY YARD AND TRANSP. TRAILER	\$445.30	
			21771	JANITORIAL SVCS-CITY HALL	\$4,588.23	
			21757	JANITORIAL SVCS-SUNNYMEAD ELEMENTARY "A CHILD'S PLACE"	\$184.10	
			21758	JANITORIAL SVCS-SUNNYMEAD MIDDLE SCHOOL-ASES	\$152.10	

Item No. A.4

-97-



**City of Moreno Valley
Payment Register
For Period 12/1/2012 through 12/31/2012**

CHECKS UNDER \$25,000

<u>Vendor Name</u>	<u>Check/EFT Number</u>	<u>Payment Date</u>	<u>Invoice Number</u>	<u>Invoice Description</u>	<u>Amount</u>	<u>FYTD</u>
WURM'S JANITORIAL SERVICES, INC.	8162	12/17/2012	21760	JANITORIAL SVCS-RAINBOW RIDGE "A CHILD'S PLACE"	\$310.19	
			21766	JANITORIAL SVCS-ESA ANNEX	\$735.73	
			21756	JANITORIAL SVCS-TOWNGATE COMM. CTR	\$691.38	
				Remit to: CORONA, CA	\$23,828.96	\$139,972.23
WURM'S JANITORIAL SERVICES, INC.	8210	12/20/2012	21660	JANITORIAL SVCS-SENIOR CENTER	\$1,916.18	
			21785	SPECIAL CLEANINGS FOR EVENT RENTALS AT TOWNGATE COMM. CTR	\$240.00	
			21761	JANITORIAL SVCS-GANG TASK FORCE OFFICE	\$112.82	
			21787	SPECIAL CLEANINGS FOR EVENT RENTALS AT SENIOR CTR.	\$130.00	
				Remit to: CORONA, CA	\$2,399.00	\$139,972.23
XEROX CORPORATION	215289	12/10/2012	065283528	COPIER LEASE FOR GRAPHICS DEPT.	\$424.11	
			065283529	COPIER LEASE FOR GRAPHICS DEPT.	\$393.44	
			065283523	COPIER RENTAL/MAINT.-PD	\$84.16	
			065283524	COPIER RENTAL/MAINT.-PD	\$92.79	
			065283525	COPIER RENTAL/MAINT.-PD	\$77.31	
				Remit to: PASADENA, CA	\$1,071.81	\$23,779.49
XEROX CORPORATION	215393	12/17/2012	065283526	COPIER LEASE/BILLABLE PRINTS FOR PARKS DEPT.	\$2,038.52	
			065283527	COPIER LEASE FOR PARKS DEPT.	\$490.76	
				Remit to: PASADENA, CA	\$2,529.28	\$23,779.49
ZACHARY F. FOSTER	8082	12/10/2012	121201	RETIREE MED BENEFIT DEC '12	\$318.73	

-98-



City of Moreno Valley
Payment Register
 For Period 12/1/2012 through 12/31/2012

CHECKS UNDER \$25,000

<u>Vendor Name</u>	<u>Check/EFT Number</u>	<u>Payment Date</u>	<u>Invoice Number</u>	<u>Invoice Description</u>	<u>Amount</u>	<u>FYTD</u>
				Remit to: GRASS VALLEY, CA	\$318.73	\$956.1
ZUMAR INDUSTRIES, INC.	8163	12/17/2012	0142070	SIGNS FOR CFD #1 PARKS	\$79.02	
			0141918	SIGNS FOR CFD #1 PARKS	\$198.44	
				Remit to: SANTA FE SPRINGS, CA	\$277.46	\$277.4
TOTAL CHECKS UNDER \$25,000					\$1,139,253.09	
GRAND TOTAL					\$13,301,776.54	

Item No. A.4

This page intentionally left blank.



APPROVALS	
BUDGET OFFICER	<i>[Signature]</i>
CITY ATTORNEY	<i>[Signature]</i>
CITY MANAGER	<i>[Signature]</i>

Report to City Council

TO: Mayor and City Council

FROM: Richard Teichert, City Treasurer

AGENDA DATE: February 26, 2013

TITLE: RECEIPT OF QUARTERLY INVESTMENT REPORT – QUARTER ENDED DECEMBER 31, 2012

RECOMMENDED ACTION

Recommendation:

1. Receive and file the Quarterly Investment Report, in compliance with the City's Investment Policy.

ADVISORY BOARD/COMMISSION RECOMMENDATION

Not applicable

BACKGROUND

California Government Code Sections 53601 and 53646 establish the types of investments allowed, the governing restrictions on these investments, the third-party custodian arrangement for certain investments, and the reporting practices related to the portfolio for local agencies. The City's Investment Policy, adopted on April 24, 2012 is in full compliance with the requirements of both of the above-mentioned Code Sections.

DISCUSSION

The attached Quarterly Investment Report presents the City's cash and investments for the quarter that ended December 31, 2012. This is the second quarterly report submitted for the 2012-13 fiscal year and is in compliance with California Government

Code Section 53646 regarding the reporting of detailed information on all securities, investments, and monies of the City, as well as the reporting of the market value of the investments held. All of the investments contained within the portfolio are in full compliance with the City's Investment Policy and Government Code Section 53601 as to the types of investments allowed. As stated in the attached report, there is more than adequate liquidity within the portfolio for the City to meet its budgeted expenditures over the next six months.

The City has used Chandler Asset Management as its professional portfolio manager since 2010. Chandler uses an active investment management approach. Utilizing an active approach, securities purchased by Chandler on the City's behalf are not necessarily held to maturity but may be actively traded based on market conditions and the City's investment goals. The City's cash flow requirements are evaluated on an ongoing basis, with short-term needs accommodated through the City's pooled investment funds with the State Local Agency Investment Fund (LAIF). LAIF is a pool of public funds managed by the State Treasurer of California, providing 24-hour liquidity while yielding a rate of return approximately equivalent to a one-year treasury bill. With the combined use of a conservative approach to evaluating cash flow needs and LAIF liquidity, the City will not have to liquidate securities at current market rates that are intended to be held for longer-term investment. This is especially important considering that the average maturity of the general portfolio is 2.34 years.

The investments managed by Chandler Asset Management totaled \$149,234,776 at par and achieved a Yield to Maturity (YTM) for December 2012 of 1.31%. This compares to a YTM in September 2012 of 1.32% and a YTM in December 2011 of 1.57%. In addition, the City maintained \$6,808,940 in the State Local Agency Investment Fund Pool (LAIF) with a YTM of .34%.

In accordance with California Government Code Section 53646, the City is properly reporting investments of all bond proceeds and Deferred Compensation Plan funds. These funds are not managed by the City Treasurer as part of the pooled investment program and were not included in the City's investment reports prior to the current legislation. Bond proceeds are held and invested by a Trustee; Deferred Compensation Plan funds are held and invested by the respective plan administrators with the funds also placed in a trust separate from City funds.

FISCAL IMPACT

Current market rates continue to hover at or near all-time lows and based on comments by the Federal Reserve Board we do not expect this to change in the near future. This interest rate environment directly impacts the ability of the portfolio to generate income. The budget for fiscal year 2012-13 projected General Fund investment earnings totaling \$2.3 million. Year to date through December 2012 these revenues have totaled \$1,077,000.

CITY COUNCIL GOALS

Revenue Diversification and Preservation. Develop a variety of City revenue sources and policies to create a stable revenue base and fiscal policies to support essential City services, regardless of economic climate.

SUMMARY

The attached Quarterly Investment Report presents the City’s cash and investments for the quarter that ended December 31, 2012. This report is in compliance with California Government Code Section 53646 regarding the reporting of detailed information on all securities, investments, and monies of the City, as well as the reporting of the market value of the investments held. All of the investments contained within the portfolio are in full compliance with the City’s Investment Policy and Government Code Section 53601 as to the types of investments allowed. It is recommended that the City Council receive and file the attached Quarterly Investment Report.

ATTACHMENTS

- Attachment 1 - Treasurer’s Cash and Investments Report – December 2012
- Attachment 2 – Chandler Asset Management Bond Market Review – January 2013

Prepared By:
 Brooke McKinney
 Treasury Operations Division Manager

Department Head Approval:
 Richard Teichert
 City Treasurer

Council Action	
Approved as requested:	Referred to:
Approved as amended:	For:
Denied:	Continued until:
Other:	Hearing set for:

This page intentionally left blank.

CITY OF MORENO VALLEY

Treasurer's Cash and Investments Report

December 2012

General Portfolio	Cost Value	Market Value	Par Value	Average Maturity	Average Yield to Maturity	Average Duration
Bank Accounts	2,143,415	2,143,415	2,143,415			
State of California LAIF Pool	6,808,940	6,808,940	6,808,940	0.66	0.34%	
Investments	153,069,818	153,983,402	149,234,776	2.45	1.31%	2.34
Total General Portfolio	162,022,173	162,935,757	158,187,131	Years		Years

Bond Proceeds with Fiscal Agents	Market Value
Construction Funds	3,371,933
Principal & Interest Accounts	536,133
Debt Service Reserve Funds	5,246,321
Custody Accounts	0
Arbitrage Rebate Accounts	0
Other Accounts	6,894
Total Bond Proceeds	9,161,281

Deferred Compensation Funds	Market Value as of Sept 30, 2012
Nationwide	10,040,212
ICMA	4,301,170
Total Deferred Compensation Funds	14,341,382

Total Investment Portfolio 186,438,420

1. I hereby certify that the investments are in compliance with the investment policy adopted by the City Council. There are no items of non-compliance for this period.
2. The market values for the specific investments in the General Portfolio are provided by the City's investment advisor, Chandler Asset Management.
3. The market value for LAIF is provided by the State Treasurer.
4. The market values for investments held by fiscal agents and the deferred compensation plans are provided by each respective trustee or fiscal agent.
5. The City has the ability to meet its budgeted expenditures for the next six months pending any future action by City Council or any unforeseen catastrophic event.

 Richard Teichert
 City Treasurer

Attachment 1

Item No. A.5

-105-



PORTFOLIO CHARACTERISTICS

Average Duration	2.34
Average Coupon	1.95 %
Average Purchase YTM	1.31 %
Average Market YTM	0.50 %
Average S&P/Moody Rating	AA/Aa1
Average Final Maturity	2.45 yrs
Average Life	2.40 yrs

ACCOUNT SUMMARY

	Beg. Values as of 11/30/12	End Values as of 12/31/12
Market Value	166,771,022	162,935,757
Accrued Interest	838,990	807,934
Total Market Value	167,610,013	163,743,691
Income Earned	184,267	180,879
Cont/WD		
Par	161,523,720	158,187,131
Book Value	163,544,836	160,020,346
Cost Value	165,809,636	162,022,173

TOP ISSUERS

Issuer	% Portfolio
Government of United States	14.6 %
Federal Farm Credit Bank	11.6 %
Federal National Mortgage Assoc	11.4 %
Federal Home Loan Mortgage Corp	9.9 %
Federal Home Loan Bank	8.1 %
Local Agency Investment Fund	4.2 %
Highmark US Govt Money Market F	3.6 %
Tennessee Valley Authority	3.2 %
	66.5 %

SECTOR ALLOCATION

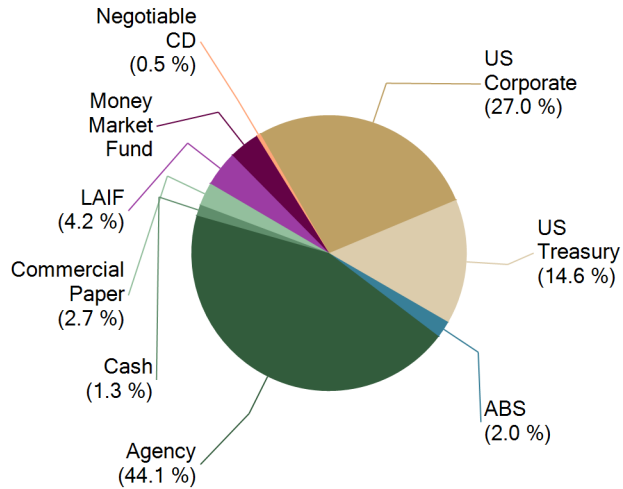

MATURITY DISTRIBUTION

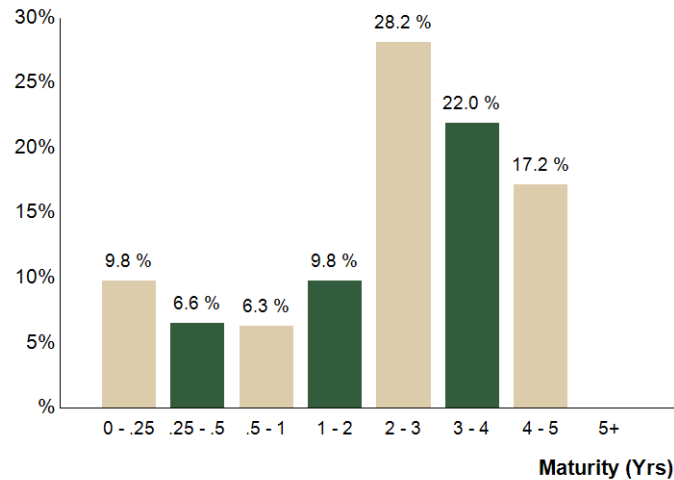

CREDIT QUALITY (S&P)

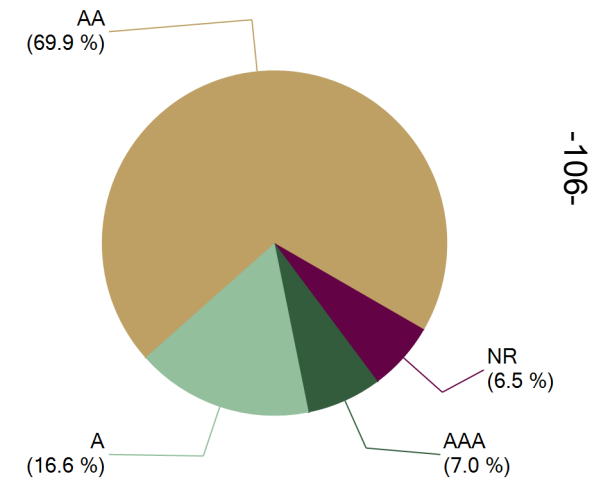

-106-



Holdings Report

As of 12/31/12

CUSIP	Security Description	Par Value/Units	Purchase Date Book Yield	Cost Value Book Value	Mkt Price Mkt YTM	Market Value Accrued Int.	% of Port. Gain/Loss	Moody S&P	Maturity Duration
ABS									
47787RAC4	John Deere Owner Trust 2012-B A3 0.53% Due 7/15/2016	1,625,000.00	08/28/2012 0.53 %	1,624,949.79 1,624,953.99	100.07 0.49 %	1,626,186.25 382.78	0.99 % 1,232.26	Aaa NR	3.54 1.86
89231NAC7	Toyota Auto Receivable 2012-B A3 0.46% Due 7/15/2016	1,620,000.00	09/18/2012 0.46 %	1,619,845.94 1,619,859.73	99.95 0.49 %	1,619,254.80 331.20	0.99 % (604.93)	Aaa AAA	3.54 1.10
Total ABS		3,245,000.00	0.50 %	3,244,795.73 3,244,813.72	0.49 %	3,245,441.05 713.98	1.98 % 627.33	Aaa AAA	3.54 1.10
AGENCY									
880591CW0	Tennessee Valley Authority Note 6% Due 3/15/2013	1,225,000.00	03/17/2010 1.65 %	1,379,797.13 1,235,338.69	101.17 0.30 %	1,239,326.38 21,641.67	0.77 % 3,987.69	Aaa AA+	0.58 0.57
31331GVD8	FFCB Note 2.2% Due 4/8/2013	1,000,000.00	05/08/2009 2.20 %	1,000,000.00 1,000,000.00	100.55 0.14 %	1,005,543.00 5,072.22	0.62 % 5,543.00	Aaa AA+	0.73 0.72
880591DW9	Tennessee Valley Authority Note 4.75% Due 8/1/2013	3,750,000.00	03/15/2010 1.90 %	4,097,325.00 3,809,670.10	102.64 0.22 %	3,848,958.75 74,218.75	2.40 % 39,288.65	Aaa AA+	0.58 0.57
31331KET3	FFCB Note 0.98% Due 9/23/2013	1,970,000.00	03/28/2011 1.10 %	1,964,227.90 1,968,315.41	100.58 0.18 %	1,981,412.21 5,255.52	1.21 % 13,096.80	Aaa AA+	0.73 0.72
31331GTJ8	FFCB Note 2.625% Due 4/17/2014	1,000,000.00	10/05/2010 1.02 %	1,055,660.00 1,020,338.14	102.26 0.86 %	1,022,605.00 5,395.83	0.63 % 2,266.86	Aaa AA+	1.29 1.27
31331JQA4	FFCB Note 1.9% Due 6/2/2014	2,850,000.00	06/08/2010 1.96 %	2,843,074.50 2,847,529.00	102.35 0.24 %	2,916,926.55 4,362.08	1.78 % 69,397.55	Aaa AA+	1.42 1.10
31331GL80	FFCB Note 3% Due 9/22/2014	1,575,000.00	03/17/2010 2.47 %	1,610,689.50 1,588,613.52	104.75 0.24 %	1,649,872.35 12,993.75	1.02 % 61,258.83	Aaa AA+	1.10 1.10
3136FPLV7	FNMA Callable Note 1X 3/24/2011 1.57% Due 9/24/2014	2,025,000.00	09/26/2011 0.65 %	2,080,181.25 2,056,885.87	102.23 0.28 %	2,070,236.48 8,566.31	1.27 % 13,350.61	Aaa AA+	1.73 1.71
3133EADW5	FFCB Note 0.55% Due 8/17/2015	3,450,000.00	04/27/2012 0.60 %	3,444,862.95 3,445,912.55	100.14 0.50 %	3,454,933.50 7,062.92	2.11 % 9,020.95	Aaa AA+	2.63 2.60
313370JB5	FHLB Note 1.75% Due 9/11/2015	1,200,000.00	08/04/2011 1.15 %	1,228,608.00 1,218,772.81	103.67 0.38 %	1,244,001.60 6,416.67	0.76 % 25,228.79	Aaa AA+	2.70 2.63
3133ECBJ2	FFCB Note 0.43% Due 11/16/2015	3,100,000.00	12/24/2012 0.45 %	3,098,233.00 3,098,241.38	100.01 0.42 %	3,100,446.40 148.11	1.89 % 2,205.02	Aaa AA+	2.88 2.85
3135G0SB0	FNMA Note 0.375% Due 12/21/2015	3,100,000.00	11/26/2012 0.45 %	3,092,777.00 3,092,990.39	99.88 0.42 %	3,096,156.00 322.92	1.89 % 3,165.61	Aaa AA+	2.97 2.95
31331J6C2	FFCB Note 2.35% Due 12/22/2015	2,000,000.00	03/28/2011 2.27 %	2,007,240.00 2,004,543.32	106.53 0.15 %	2,130,634.00 1,175.00	1.30 % 126,090.68	Aaa AA+	2.98 2.89
3136FPDC8	FNMA Callable Note 1X 3/8/2011 2% Due 3/8/2016	1,765,000.00	08/24/2011 1.22 %	1,825,645.40 1,807,528.64	104.89 0.45 %	1,851,336.74 11,080.28	1.14 % 43,808.10	Aaa AA+	3.19 3.08
313372YS7	FHLB Note 2.45% Due 3/30/2016	2,150,000.00	07/07/2011 1.87 %	2,206,631.00 2,188,825.19	106.26 0.51 %	2,284,482.50 13,315.07	1.40 % 95,657.31	Aaa AA+	3.25 3.12
3137EACT4	FHLMC Note 2.5% Due 5/27/2016	1,200,000.00	06/14/2011 1.86 %	1,235,992.80 1,224,752.52	106.70 0.51 %	1,280,344.80 2,833.33	0.78 % 55,592.28	Aaa AA+	3.41 3.28

Item No. A.5
107



Holdings Report

As of 12/31/12

CUSIP	Security Description	Par Value/Units	Purchase Date Book Yield	Cost Value Book Value	Mkt Price Mkt YTM	Market Value Accrued Int.	% of Port. Gain/Loss	Moody S&P	Maturity Duration
AGENCY									
313373SZ6	FHLB Note 2.125% Due 6/10/2016	3,350,000.00	Various 1.42 %	3,456,779.50 3,427,798.06	105.51 0.51 %	3,534,531.40 4,152.61	2.16 % 106,733.34	Aaa AA+	3.44 3.33
31359MS61	FNMA Note 5.375% Due 7/15/2016	2,700,000.00	10/13/2011 1.29 %	3,206,106.90 3,077,242.50	116.95 0.53 %	3,157,614.90 66,918.75	1.97 % 80,372.40	Aaa AA+	3.54 3.22
3137EACW7	FHLMC Note 2% Due 8/25/2016	3,475,000.00	09/14/2011 1.19 %	3,610,316.50 3,574,801.54	105.24 0.55 %	3,657,215.10 24,325.00	2.25 % 82,413.56	Aaa AA+	3.65 3.51
3135G0CM3	FNMA Note 1.25% Due 9/28/2016	1,300,000.00	Various 1.22 %	1,301,462.70 1,301,243.28	102.59 0.55 %	1,333,728.50 4,197.92	0.82 % 32,485.22	Aaa AA+	3.75 3.65
3135G0ES8	FNMA Note 1.375% Due 11/15/2016	3,400,000.00	01/24/2012 1.17 %	3,431,885.20 3,425,704.49	103.02 0.59 %	3,502,646.00 5,973.61	2.14 % 76,941.51	Aaa AA+	3.88 3.77
3135G0GY3	FNMA Note 1.25% Due 1/30/2017	3,425,000.00	02/09/2012 1.10 %	3,449,368.88 3,445,038.43	102.52 0.62 %	3,511,193.55 17,957.47	2.16 % 66,155.12	Aaa AA+	4.08 3.96
3133787M7	FHLB Note 1.05% Due 2/27/2017	1,720,000.00	02/27/2012 1.03 %	1,721,582.40 1,721,315.49	101.48 0.69 %	1,745,516.20 6,220.67	1.07 % 24,200.71	Aaa AA+	4.16 4.05
3137EADC0	FHLMC Note 1% Due 3/8/2017	3,490,000.00	03/14/2012 1.29 %	3,441,314.50 3,449,129.87	101.27 0.69 %	3,534,480.05 10,954.72	2.17 % 85,350.18	Aaa AA+	4.19 4.08
313378WF4	FHLB Note 1.125% Due 3/10/2017	3,435,000.00	04/24/2012 1.05 %	3,447,228.60 3,445,504.23	101.78 0.69 %	3,496,280.40 11,915.16	2.14 % 50,776.17	Aaa AA+	4.19 4.08
3137EADF3	FHLMC Note 1.25% Due 5/12/2017	3,300,000.00	05/29/2012 1.06 %	3,330,600.90 3,326,945.04	102.32 0.71 %	3,376,454.40 5,614.58	2.07 % 49,509.36	Aaa AA+	4.36 4.24
313379VE6	FHLB Note 1.01% Due 6/19/2017	915,000.00	07/26/2012 0.82 %	923,363.10 922,624.08	101.19 0.74 %	925,862.88 308.05	0.57 % 3,238.80	Aaa AA+	4.10 4.08
3137EADH9	FHLMC Note 1% Due 6/29/2017	3,150,000.00	Various 0.85 %	3,171,475.20 3,170,063.48	101.24 0.72 %	3,189,135.60 175.00	1.95 % 19,072.12	Aaa AA+	4.50 4.39
3133EAY28	FFCB Note 0.83% Due 9/21/2017	1,645,000.00	09/18/2012 0.83 %	1,645,000.00 1,645,000.00	100.17 0.79 %	1,647,775.12 3,792.64	1.01 % 2,775.12	Aaa AA+	4.73 4.61
3137EADL0	FHLMC Note 1% Due 9/29/2017	1,050,000.00	10/25/2012 0.92 %	1,053,983.70 1,053,843.88	101.05 0.77 %	1,061,032.35 2,683.33	0.65 % 7,188.47	Aaa AA+	4.75 4.62
Total Agency		69,715,000.00	1.23 %	71,361,413.51 70,594,511.90	0.50 %	71,850,682.71 345,049.94	44.09 % 1,256,170.81	Aaa AA+	3.10 3.01
CASH									
90CASH\$00	Cash Custodial Cash Account	2,143,414.78	Various 0.00 %	2,143,414.78 2,143,414.78	1.00 0.00 %	2,143,414.78 0.00	1.31 % 0.00	NR NR	0.00 0.00
Total Cash		2,143,414.78	N/A	2,143,414.78 2,143,414.78	0.00 %	2,143,414.78 0.00	1.31 % 0.00	NR NR	0.00 0.00
COMMERCIAL PAPER									
40427RR52	HSBC USA Inc Discount CP 0.26% Due 4/5/2013	1,250,000.00	12/19/2012 0.26 %	1,249,043.05 1,249,151.38	99.93 0.26 %	1,249,151.38 0.00	0.76 % 0.00	P-1 A-1	0.26 0.26

108-



Holdings Report

As of 12/31/12

CUSIP	Security Description	Par Value/Units	Purchase Date Book Yield	Cost Value Book Value	Mkt Price Mkt YTM	Market Value Accrued Int.	% of Port. Gain/Loss	Moody S&P	Maturity Duration
COMMERCIAL PAPER									
89233GS15	Toyota Motor Credit Discount CP 0.265% Due 5/1/2013	3,200,000.00	Various 0.27 %	3,195,971.54 3,197,173.32	99.91 0.27 %	3,197,173.32 0.00	1.95 % 0.00	P-1 A-1+	0.33 0.33
Total Commercial Paper		4,450,000.00	0.27 %	4,445,014.59 4,446,324.70	0.27 %	4,446,324.70 0.00	2.72 % 0.00	P1 A-1	0.31 (
LAIF									
90LAIF\$00	Local Agency Investment Fund State Pool	6,808,940.38	Various 0.32 %	6,808,940.38 6,808,940.38	1.00 0.32 %	6,808,940.38 9,630.31	4.16 % 0.00	NR NR	((
Total LAIF		6,808,940.38	0.32 %	6,808,940.38	0.32 %	6,808,940.38 9,630.31	4.16 % 0.00	NR NR	((
MONEY MARKET FUND FI									
431114701	Highmark Govt Money Market Fund	5,884,776.22	Various 0.00 %	5,884,776.22 5,884,776.22	1.00 0.00 %	5,884,776.22 0.00	3.59 % 0.00	Aaa AAA	0.00 0.00
Total Money Market Fund FI		5,884,776.22	0.00 %	5,884,776.22	0.00 %	5,884,776.22 0.00	3.59 % 0.00	Aaa AAA	0.00 0.00
NEGOTIABLE CD									
89112XA62	Toronto Dominion Bank Negotiable CD 0.5% Due 6/21/2013	800,000.00	11/30/2012 0.25 %	801,123.64 800,946.51	100.12 0.25 %	800,946.51 355.56	0.49 % 0.00	P-1 A-1+	0.47, 109- 0.47, 109-
Total Negotiable CD		800,000.00	0.25 %	801,123.64 800,946.51	0.25 %	800,946.51 355.56	0.49 % 0.00	Aaa AAA	0.47, 109-
US CORPORATE									
931142CL5	Wal-Mart Stores Note 4.25% Due 4/15/2013	3,260,000.00	Various 1.54 %	3,491,366.25 3,284,557.24	101.12 0.38 %	3,296,417.46 29,249.45	2.03 % 11,860.22	Aa2 AA	0.29 0.29
459200GR6	IBM Corp Note 2.1% Due 5/6/2013	1,225,000.00	01/27/2011 1.00 %	1,255,269.75 1,229,564.20	100.62 0.30 %	1,232,644.00 3,930.21	0.76 % 3,079.80	Aa3 AA-	0.35 0.35
91159HGY0	US Bancorp Callable Note Cont 8/13/13 1.375% Due 9/13/2013	2,665,000.00	Various 1.32 %	2,668,966.65 2,665,819.20	100.58 0.42 %	2,680,574.26 10,993.13	1.64 % 14,755.06	A1 A+	0.70 0.62
254687AW6	Walt Disney Corp Note 4.5% Due 12/15/2013	1,720,000.00	Various 1.23 %	1,873,880.60 1,772,461.88	103.88 0.42 %	1,786,780.72 3,440.00	1.09 % 14,318.84	A2 A	0.96 0.94
24422ERA9	John Deere Capital Corp Note 1.6% Due 3/3/2014	440,000.00	02/28/2011 1.63 %	439,564.40 439,830.69	101.31 0.48 %	445,771.92 2,307.56	0.27 % 5,941.23	A2 A	1.17 1.16
665859AK0	Northern Trust Company Note 4.625% Due 5/1/2014	1,850,000.00	10/20/2010 1.33 %	2,058,421.00 1,928,726.00	105.38 0.57 %	1,949,557.75 14,260.42	1.20 % 20,831.75	A1 A+	1.33 1.30
36962G4C5	General Electric Capital Corp Note 5.9% Due 5/13/2014	3,075,000.00	Various 2.88 %	3,411,681.00 3,193,725.54	107.17 0.62 %	3,295,523.63 24,190.00	2.03 % 101,798.09	A1 AA+	1.36 1.32
74005PAQ7	Praxair Note 5.25% Due 11/15/2014	850,000.00	09/24/2010 1.60 %	973,471.00 905,922.21	108.69 0.57 %	923,901.55 5,702.08	0.57 % 17,979.34	A2 A	1.87 1.80

Item No. A.5



Holdings Report

As of 12/31/12

CUSIP	Security Description	Par Value/Units	Purchase Date Book Yield	Cost Value Book Value	Mkt Price Mkt YTM	Market Value Accrued Int.	% of Port. Gain/Loss	Moody S&P	Maturity Duration
US CORPORATE									
09247XAD3	Blackrock Inc Note 3.5% Due 12/10/2014	1,630,000.00	Various 2.84 %	1,674,920.75 1,649,357.18	105.61 0.59 %	1,721,467.46 3,327.92	1.05 % 72,110.28	A1 A+	1.94 1.89
713448BM9	Pepsico Inc. Note 3.1% Due 1/15/2015	2,530,000.00	Various 2.04 %	2,641,540.25 2,581,846.02	104.96 0.65 %	2,655,376.68 36,164.95	1.64 % 73,530.66	Aa3 A-	2.04 1.96
46625HHP8	JP Morgan Chase Note 3.7% Due 1/20/2015	2,550,000.00	Various 3.34 %	2,584,656.00 2,567,609.13	105.29 1.09 %	2,684,849.10 42,195.42	1.67 % 117,239.97	A2 A	2.05 1.96
459200HB0	IBM Corp Note 0.55% Due 2/6/2015	695,000.00	02/01/2012 0.72 %	691,601.45 692,624.74	100.02 0.54 %	695,129.27 1,539.62	0.43 % 2,504.53	Aa3 AA-	2.10 2.08
94980VAA6	Wells Fargo Bank Note 4.75% Due 2/9/2015	2,475,000.00	Various 3.65 %	2,584,316.50 2,527,421.29	107.40 1.18 %	2,658,192.08 46,371.87	1.65 % 130,770.79	A1 A+	2.11 1.99
084670AV0	Berkshire Hathaway Note 3.2% Due 2/11/2015	2,485,000.00	06/09/2010 2.65 %	2,545,012.75 2,512,169.60	105.28 0.68 %	2,616,165.76 30,924.44	1.62 % 103,996.16	Aa2 AA+	2.12 2.03
191216AX8	Coca Cola Company Note 0.75% Due 3/13/2015	2,090,000.00	Various 0.80 %	2,086,645.55 2,087,541.02	100.76 0.40 %	2,105,919.54 4,702.50	1.29 % 18,378.52	Aa3 AA-	2.20 2.18
06406JHB4	Bank of New York Mellon Note 4.95% Due 3/15/2015	2,360,000.00	Various 2.11 %	2,645,950.90 2,499,712.91	109.03 0.81 %	2,573,077.33 34,397.01	1.59 % 73,364.42	A1 A	2.20 2.09
717081DA8	Pfizer Inc. Note 5.35% Due 3/15/2015	1,550,000.00	02/18/2011 2.33 %	1,730,497.50 1,647,932.09	110.13 0.71 %	1,707,024.30 24,416.81	1.06 % 59,092.21	A1 AA	2.20 2.08
74005PAR5	Praxair Note 4.625% Due 3/30/2015	740,000.00	Various 2.58 %	807,780.55 771,766.20	108.88 0.64 %	805,677.96 8,651.32	0.50 % 33,911.76	A2 A	2.24 2.14
278642AB9	Ebay Inc Note 1.625% Due 10/15/2015	2,670,000.00	10/22/2010 1.66 %	2,665,327.50 2,667,378.97	102.68 0.65 %	2,741,606.73 9,159.58	1.68 % 74,227.76	A2 A	2.10 2.10
38259PAC6	Google Inc Note 2.125% Due 5/19/2016	1,315,000.00	11/15/2012 0.75 %	1,377,186.90 1,375,140.00	104.42 0.80 %	1,373,125.63 3,260.10	0.84 % (2,014.37)	Aa2 AA	3.38 3.26
24422ERL5	John Deere Capital Corp Note 2% Due 1/13/2017	1,215,000.00	09/11/2012 1.05 %	1,263,733.65 1,260,375.90	103.47 1.12 %	1,257,186.01 11,340.00	0.77 % (3,189.89)	A2 A	4.04 3.84
913017BU2	United Tech Corp Note 1.8% Due 6/1/2017	170,000.00	05/24/2012 1.82 %	169,853.80 169,870.93	102.94 1.12 %	174,990.86 255.00	0.11 % 5,119.93	A2 A	4.42 4.24
166764AA8	Chevron Corp. Callable Note Cont 11/5/17 1.104% Due 12/5/2017	550,000.00	11/28/2012 1.10 %	550,000.00 550,000.00	100.70 0.96 %	553,840.10 438.53	0.34 % 3,840.10	Aa1 AA	4.93 4.78
458140AL4	Intel Corp Note 1.35% Due 12/15/2017	1,940,000.00	12/12/2012 1.29 %	1,945,790.55 1,945,742.93	99.97 1.36 %	1,939,439.35 1,455.00	1.19 % (6,303.58)	A1 A+	4.96 4.77
Total US Corporate		42,050,000.00	1.95 %	44,137,435.25 42,927,095.87	0.70 %	43,874,239.45 352,672.92	27.01 % 947,143.58	A1 A+	1.99 1.92
US TREASURY									
912828NP1	US Treasury Note 1.75% Due 7/31/2015	4,050,000.00	04/06/2011 1.99 %	4,009,355.36 4,025,731.85	103.66 0.33 %	4,198,076.10 29,659.65	2.58 % 172,344.25	Aaa AA+	2.58 2.52
912828PE4	US Treasury Note 1.25% Due 10/31/2015	3,600,000.00	Various 1.35 %	3,584,379.25 3,589,962.13	102.54 0.35 %	3,691,407.60 7,707.19	2.26 % 101,445.47	Aaa AA+	2.83 2.78



Holdings Report

As of 12/31/12

CUSIP	Security Description	Par Value/Units	Purchase Date Book Yield	Cost Value Book Value	Mkt Price Mkt YTM	Market Value Accrued Int.	% of Port. Gain/Loss	Moody S&P	Maturity Duration
US TREASURY									
912828PJ3	US Treasury Note 1.375% Due 11/30/2015	3,590,000.00	05/16/2011 1.63 %	3,549,905.00 3,564,262.69	102.94 0.36 %	3,695,456.25 4,339.56	2.26 % 131,193.56	Aaa AA+	2.92 2.86
912828PS3	US Treasury Note 2% Due 1/31/2016	3,505,000.00	05/16/2011 1.70 %	3,551,973.24 3,535,759.54	104.95 0.39 %	3,678,332.77 29,335.33	2.26 % 142,573.23	Aaa AA+	3.08 2.86
912828QA1	US Treasury Note 2.25% Due 3/31/2016	3,435,000.00	Various 1.33 %	3,578,212.10 3,533,518.11	105.96 0.40 %	3,639,756.92 19,746.53	2.23 % 106,238.81	Aaa AA+	3.08 3.08
912828RU6	US Treasury Note 0.875% Due 11/30/2016	3,200,000.00	12/22/2011 0.89 %	3,198,135.71 3,198,519.96	101.41 0.51 %	3,245,251.20 2,461.54	1.98 % 46,731.24	Aaa AA+	3.08 3.08
912828SC5	US Treasury Note 0.875% Due 1/31/2017	1,710,000.00	06/20/2012 0.70 %	1,723,298.31 1,721,767.23	101.33 0.55 %	1,732,710.51 6,261.48	1.06 % 10,943.28	Aaa AA+	4.00 3.08
Total US Treasury		23,090,000.00	1.44 %	23,195,258.97 23,169,521.51	0.40 %	23,880,991.35 99,511.28	14.65 % 711,469.84	Aaa AA+	3.08 3.08
TOTAL PORTFOLIO		158,187,131.38	1.31 %	162,022,173.07 160,020,345.59	0.50 %	162,935,757.15 807,933.99	100.00 % 2,915,411.56	Aa1 AA	2.45 2.34
TOTAL MARKET VALUE PLUS ACCRUED						163,743,691.14			

Item No. A.5

-111-



COMPLIANCE WITH INVESTMENT POLICY

Assets managed by Chandler Asset Management are in full compliance with State law and with the City's investment policy.

Category	Standard	Comment
Local Agency Bonds	No Limitation	Complies
Treasury Issues	No Limitation	Complies
Agency Issues	No Limitation	Complies
Banker's Acceptances	40% maximum; <180 days maturity	Complies
Commercial Paper	25% maximum; <270 days maturity; A-1/P-1/F-1 minimum ratings	Complies
Negotiable Certificates of Deposit	30% maximum; 5 years maximum maturity	Complies
Repurchase Agreements	No limitation; 1-year maximum maturity	Complies
Reverse Repurchase Agreements	20% maximum; <92 days maturity	Complies
Medium Term Notes	30% maximum; 5 years maximum maturity; A-rated or better	Complies
Money Market Mutual Funds	20% maximum; AA Af/Aaaf, minimum rating	Complies
Collateralized Certificates of Deposits	5 years maximum maturity	Complies
Time Deposits	5 years maximum maturity	Complies
Mortgage Pass-throughs, CMOs and Asset Backed Securities	20% maximum; AA-rated issue; A-rated issuer	Complies
Local Agency Investment Fund - L.A.I.F.	Maximum program limitation	Complies
Prohibited Securities	Inverse floaters; Ranges notes, Interest- only strips from mortgaged backed securities; Zero interest accrual securities	Complies
Maximum maturity	5 years	Complies



Holdings Report Glossary

Item No. A.5

-113-

CUSIP (Committee on Uniform Securities Identification Procedures) – A unique identification number assigned to all securities.

Security Description - The issuer name, coupon (periodic interest payment rate) and maturity.

Par Value/Units - The face value or number of units held in the portfolio.

Purchase Date - The settlement date on which the security was purchased.

Book Yield - The YTM that equates the current amortized value of the security to its periodic future cash flows.

Cost Value - The value at which the securities were purchased, excluding purchased interest.

Book Value - The value at which an asset is carried on a balance sheet. To calculate, take the cost of an asset +/- net accretion/amortization.

Mkt Price - The current fair value market price.

Mkt YTM – The internal rate of return that equates the periodic future cash flows (interest payments and redemption value) to the market price, assuming that all cash flows are invested at the YTM rate.

Market Value - The current fair value of an investment as determined by transactions between willing buyers and sellers.

Accrued Int. - The interest that has accumulated on a bond since the last interest payment up to, but not including, the settlement date.

% of Port. - The % of the portfolio that the security represents based on market value, including accrued interest.

Gain/Loss – The unrealized gain or loss on the security, compared to either cost or amortized value, as of the date of the report.

Moody - The Moody's rating for the security.



Holdings Report Glossary (continued)

S&P - The Standard and Poor's rating for the security.

Term (yrs) - The time, in years, until maturity.

Duration - The weighted average time to maturity of a bond where the weights are the present values of future cash flows. Duration measures the price sensitivity of a bond to changes in interest rates.

BOND PROCEEDS WITH FISCAL AGENTS

Account Name	Account Number	Investment	Issuer	Purchase Date	Maturity Date	Market Value	Stated Rate	Yield	Price	% of Portfolio
Wells Fargo		Community Facilities District 87-1 (IA-1)								
special tax funds	22631800	money market fund	WF Govt Fund	12/31/12	01/01/13	182,001	0.01%	0.01%	1.00000	1.987%
reserve fund	22631804	money market fund	WF Govt Fund	12/31/12	01/01/13	1,029,050	0.01%	0.01%	1.00000	11.233%
admin exp acct	22631805	money market fund	WF Govt Fund	12/31/12	01/01/13	377	0.01%	0.01%	1.00000	0.004%
debt service acct	22631809	money market fund	WF Govt Fund	12/31/12	01/01/13	535,973	0.01%	0.01%	1.00000	5.850%
special tax funds	22631900	money market fund	WF Govt Fund	12/31/12	01/01/13	105,196	0.01%	0.01%	1.00000	1.148%
reserve fund	22631904	money market fund	WF Govt Fund	12/31/12	01/01/13	365,360	0.01%	0.01%	1.00000	3.988%
admin exp acct	22631905	money market fund	WF Govt Fund	12/31/12	01/01/13	8	0.01%	0.01%	1.00000	0.000%
						2,217,965				
Wells Fargo		CFD # 5								
Series B Revenue	22333500	money mkt fund	WF Govt Fund	12/31/12	01/01/13	6,483	0.01%	0.01%	1.00000	0.071%
Series B reserve	22333503	money mkt fund	WF Govt Fund	12/31/12	01/01/13	537,940	0.01%	0.01%	1.00000	5.872%
Series B admin fund	22333504	money mkt fund	WF Govt Fund	12/31/12	01/01/13	127	0.01%	0.01%	1.00000	0.001%
						544,550				
Wells Fargo		2007 Redevelopment Agency Tax Allocation Bonds Sereis A								
debt service fund	22631700	money mkt fund	WF Govt Fund	12/31/12	01/01/13	2	0.01%	0.01%	1.00000	0.000%
						2				
Wells Fargo		2005 Lease Revenue Bond								
bond fund	18042800	money mkt fund	WF Govt Fund	12/31/12	01/01/13	30	0.01%	0.01%	1.00000	0.000%
reserve fund	18042804	money mkt fund	WF Govt Fund	12/31/12	01/01/13	2,992,753	0.01%	0.01%	1.00000	32.667%
construction fund	18042806	money mkt fund	WF Govt Fund	12/31/12	01/01/13	1,315,143	0.01%	0.01%	1.00000	14.355%
						4,307,926				
Wells Fargo		2007 Taxable Lease Revenue Bonds - Electric Utility								
bond fund	22277600	money mkt fund	WF Govt Fund	12/31/12	01/01/13	3	0.01%	0.01%	1.00000	0.000%
construction fund	22277604	investment agrmnt		12/31/12	01/01/13	2,056,790	0.01%	0.01%	1.00000	22.451%
						2,056,793				
Wells Fargo		Automall Refinancing								
revenue fund	20350300	revenue	WF Govt Fund	12/31/12	01/01/13	1	0.01%	0.01%	1.00000	0.000%
reserve fund	20350303	reserve	WF Govt Fund	12/31/12	01/01/13	34,018	0.01%	0.01%	1.00000	0.371%
admin fund	20350304	reserve	WF Govt Fund	12/31/12	01/01/13	26	0.01%	0.01%	1.00000	0.000%
						34,045				
Totals						9,161,281				

Type	Summary of Bond Proceeds with Fiscal Agents	
1	Construction Funds	3,371,933
2	Principal & Interest Accounts	536,133
3	Debt Service Reserve Funds	5,246,321
4	Custody Accounts	0
5	Arbitrage Rebate Accounts	0
6	Other Accounts	6,894
Total Fiscal Agent Funds		9,161,281

DEFERRED COMPENSATION FUNDS

Nationwide

Fund	Market Value as of Sept 30,2012	Fund	Market Value as of Sept 30,2012	Fund	Market Value as of Sept 30,2012
Liquid Savings	\$1,234,006	Drey SmCap I	6	N B Socially Responsive Fund	25,346
Nationwide Fixed (Part Time Employee)	494,757	American Century Balanced	34	DFA US Micro Cap Port	66,330
Liquid Savings (Part Time Employees)	269,863	Am Century Growth	57,154	Federated Kaufmann Fund	87,475
Certificates of Deposit 1 year	30,011	Am Century Select	110,058	Invesco Mid Cap Core Equity	21,615
Certificates of Deposit 3 years	15,635	JP Morgan Mid Cap Value A	659,960	Nationwide Ret Inc Inst Svc	219
Certificates of Deposit 5 years	82,558	Vanguard Index 500	91,313	Nationwide InvDes Mod Cons Fund SC	27,698
Bond Fund of America	61,047	Vanguard Institutional Index	458,461	Nationwide InvDes Mod Aggr Fund	787,858
Growth Fund of America	82,763	Vanguard Wellington	17,192	Nationwide InvDes Aggr Fund	51,226
Investment Co. of America	30,179	Vanguard Windsor II	54,975	Nationwide InvDes Mod Fd	461,507
Income Fund of America	106,571	Vanguard Total Bond Index	210,717	Nationwide Inv Des Cons	118,237
Brown Cap Mgmt Inc SM Co	41,040	Washington Mutual Inv	65,889	Nationwide Large Cap Growth	46,515
Fidelity Independence	1,742	Templeton Foreign I		Nationwide Inter Val Inst Svc	18,097
Fidelity Equity Income	35,648	EuroPacific Growth	259,744	Nationwide US Sm Cap Val Ins Svc	1,081
Fidelity Magellan	217,182	Stable Fund C	2,645,316	Nationwide Dest 2020 Inst Svc	113,837
Fidelity Puritan	82,829	PBHG Growth Fund		Nationwide Dest 2025 Inst Svc	88,179
Fidelity Contrafund	199,478	DWS High Income Fund A	85,157	Nationwide Dest 2030 Inst Svc	37,124
Janus Fund	58,418	DWS Eq Divd A	55,257	Nationwide Dest 2045 Inst Svc	3,634
Janus Advisor Forty	44,445	Oppenheimer Global Fund A	224,829	Total Nationwide Deferred	\$10,040,212

ICMA

Fund	Market Value as of Sept 30,2012	Fund	Market Value as of Sept 30,2012
Aggressive Oppor.	\$183,810	VT Royce Premeir	3,925
International	193,850	VT Ranier Small/Mid Cap Eq	36,685
All Equity Growth	124,993	VT Fidelity Contrafund	140,037
Growth and Income	216,330	VT Vantagepoint Overseas Equity Index Fund	74,541
Broad Market	64,872	VT Fidelity Diversified International	79,626
500 Stock Index	74,138	VT Allianz NFJ Div Value	48,053
Equity Income	287,995	Vantage Growth Fund	231,198
Asset Allocation		VT Fidelity Puritan	5,841
Core Bond	77,173	VT Calvert Equity Portfolio	3
Cash Management	26,090	VT TR Price Growth Stock Adv	19,368
Plus Fund	1,068,610	VT Nuveen Real Estate Secs	39,768
Savings Oriented	20,198	VT TR Price Small Cap Value	124,871
Conservative Growth	160,149	VT Vantagepoint MS Ret Inc	34,929
Traditional Growth	260,168	VT Vantagepoint Inflation Protected Securities	85,222
Long-Term Growth	345,041	VT Vantagepoint Select Value	36
Milestone 2010	14,103	VT Vantagepoint Mid/Sm Index	15,763
Milestone 2015	852	VT PIMCO Total Return	115,385
Milestone 2020	50	VT PIMCO High Yield	58,065
Milestone 2025	19,002	VT Harbor International Admi	17,534
Milestone 2030	12,634	VT Harbour Mid Cap Growth Admin	
Milestone 2035	15,501		
Milestone 2040	4,761	Total ICMA	\$4,301,170

Summary by Plan

Deferred Compensation Plan	Market Value as of Sept 30,2012
Total Nationwide	\$10,040,212
Total ICMA	4,301,170
Total Deferred Compensation Plans	\$14,341,382

Summary by Investment Type

Investment Type	Market Value as of Sept 30,2012
Savings Deposits and CD's	\$4,689,588
Mutual Funds	9,651,794
Total Deferred Compensation Plans	\$14,341,382

BOND MARKET REVIEW

A MONTHLY REVIEW OF
FIXED INCOME MARKETS



WHAT'S INSIDE

Market Summary 1
Yield Curve
Current Yields

Economic Round-Up 2
Credit Spreads
Economic Indicators

Treasury Debt: How Much . . . 3
Is Available for Private
Investors?

Since 1988, Chandler Asset Management has specialized in the management of fixed income portfolios. Chandler's mission is to provide fully customizable, client-centered portfolio management that preserves principal, manages risk and generates income in our clients' portfolios.

Market Summary

The economy continues to grow at a slower than desired pace. Improvement in the labor market has been modest, while trends in the manufacturing sector have been sluggish and reports on the consumer have been mixed. Payroll growth was in line with expectations in December, up 155,000, and the unemployment rate remains elevated at 7.8%. Housing data, on the other hand, has been favorable and recent reports suggest that the housing market continues to firm. Congress finally passed legislation to avert the fiscal cliff on January 1st; however, they failed to address the debt ceiling and in two months the U.S. will face the need to increase its borrowing limit. Congress is expected to resume negotiations regarding fiscal spending and sequestration as the debt ceiling nears.

Yields remain within a relatively tight range at low levels, as domestic economic growth remains slow and the outlook for the global economy remains tenuous. Rates continue to be influenced by the Federal Reserve's accommodative monetary policy, continued purchase of securities onto their balance sheet, and their desire to keep interest rates contained.

The Federal Open Market Committee left policy rates unchanged at its December meeting at a target range of 0%-0.25%, and announced a plan to implement additional quantitative easing. The Fed said it will purchase longer-term Treasuries at a pace of \$45 billion per month for an unspecified period of time beginning this month. This program essentially replaces "Operation Twist" which expired at the end of December. The Fed also said that it will continue to purchase additional agency mortgage-backed securities at a pace of \$40 billion per month, for an open-ended period of time. The Fed said that an exceptionally low fed funds rate will be appropriate as long as unemployment remains above 6.5% or until inflation looks set to exceed 2.5%. Overall, the Federal Reserve continues to pursue aggressive stimulus programs, and is forecasting slightly faster economic growth this year and a gradual decline in unemployment.

SHORTER-TERM TREASURY YIELDS DECLINED SLIGHTLY WHILE LONGER-TERM YIELDS ROSE

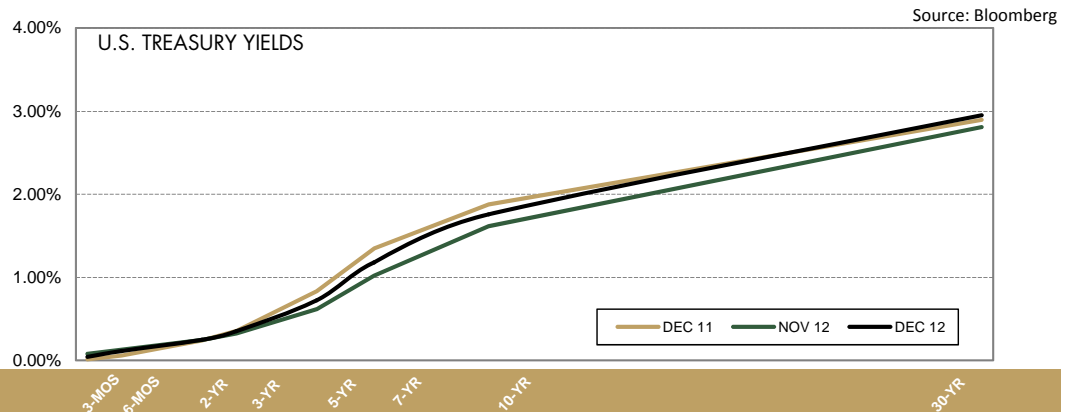

Yields have remained within a tight range at low levels, as uncertainties about the domestic and global economy persist. Rates also continue to be influenced by the Federal Reserve's accommodative monetary policy, continued purchase of securities onto their balance sheet, and their desire to keep interest rates contained.

TREASURY YIELDS	12/31/2012	11/30/12	CHANGE
3 Month	0.04	0.08	(0.04)
2 Year	0.25	0.25	0.00
3 Year	0.35	0.32	0.03
5 Year	0.72	0.62	0.10
7 Year	1.18	1.04	0.14
10 Year	1.76	1.62	0.14
30 Year	2.95	2.81	

Economic Roundup

Consumer Prices

In November, overall CPI inflation fell to 1.8% on a year-over-year basis from 2.2% in October. The year-over-year Core CPI (CPI less food and energy) also fell slightly to 1.9% from 2.0% in October. The core inflation rate is below the Fed's long-term goal of 2.0% and well below the trigger rate for policy action of 2.5%.

Retail Sales

In November, Retail Sales rose 3.7% on a year-over-year basis. On a month-over-month basis, Retail Sales rose 0.3% in November, lower than the consensus forecast of 0.6%. Overall, recent consumer spending trends have been modest.

Labor Markets

The December employment report showed that payrolls increased by 155,000 (in line with the consensus estimate), following a gain of 161,000 in November. Private payrolls advanced 168,000 while government jobs declined by 13,000. The unemployment rate held steady at 7.8% in December. Overall, improvement in the labor market continues to be modest and reflects an overall slow pace of growth in the domestic economy.

Housing Starts

Single-family housing starts declined 4.0% in November to 565,000 from 589,000 in October. However, housing permits rose 3.6% in November. Overall, housing starts fell back slightly in November after two months of strong gains. In our view, recent data suggests that the housing market continues to be firm.

Credit Spreads Were Mixed

CREDIT SPREADS	Spread to Treasuries (%)	One Month Ago (%)	Change
3-month top-rated commercial paper	0.17	0.11	0.06
2-year A corporate note	0.60	0.57	0.03
5-year A corporate note	0.86	0.89	(0.03)
5-year Agency note	0.24	0.22	0.02

Source: Bloomberg

Data as of 12/31/12

Economic Data Continued at a Slow Pace

ECONOMIC INDICATOR	Current Release	Prior Release	One Year Ago
Trade Balance	(42.2) \$Bln OCT 12	(40.3) \$Bln SEP 12	(45.7) \$Bln OCT 11
GDP	3.1% SEP 12	1.3% JUN 12	1.3% SEP 11
Unemployment Rate	7.8% DEC 12	7.8% NOV 12	8.5% DEC 11
Prime Rate	3.25% DEC 12	3.25% NOV 12	3.25% DEC 11
CRB Index	295.01 DEC 12	298.98 NOV 12	305.30 DEC 11
Oil (West Texas Int.)	\$91.82 DEC 12	\$88.91 NOV 12	\$98.83 DEC 11
Consumer Price Index (y/o/y)	1.8% NOV 12	2.2% OCT 12	3.4% NOV 11
Producer Price Index (y/o/y)	1.5% NOV 12	2.3% OCT 12	5.6% NOV 11
Dollar/EURO	1.32 DEC 12	1.30 NOV 12	1.30 DEC 11

Source: Bloomberg

© 2012 Chandler Asset Management, Inc. An Independent Registered Investment Adviser.

The information contained herein was obtained from sources we believe to be reliable, but we do not guarantee its accuracy. Opinions and forecasts regarding industries, companies, and/or the economy are all subject to change at any time, based on market and other conditions, and should not be construed as a recommendation.

Treasury Debt: How Much is Available for Private Investors?

As we have discussed in our previous commentary, the available supply of safe-haven assets has dwindled for investors. The tenuous global economic backdrop has contributed to the lack of safe, sovereign assets as the debt of peripheral European countries are no longer perceived as “risk free”. China does not have a developed global bond market and Japan finances their deficit via the domestic economy, and thus neither represents realistic substitutes for global safe-haven flows. In the current investment environment, arguably the only two sovereign markets with the depth, safety, and transparency to be considered risk free are German Bunds and US Treasuries. Investors covet safe-haven assets, particularly in times of heightened uncertainty, yet there are fewer such assets available on a global basis.

Recently, domestic market sentiment has been strongly impacted by political developments. As part of the fiscal cliff negotiations that concluded at year-end, existing tax rates were extended for the majority of the population. However, significant milestones remain in the coming quarter, including the extension of the debt ceiling above \$16.4 trillion, the government’s actions on the impact of sequestration, and the continuing spending resolution for 2013 (which runs out at the end of March). We analyze the changing Treasury debt investment landscape from the perspective of fiscal policy and developments, economic issues, and the Federal Reserve’s objectives.

The level of conventional monetary stimulus being injected into the US economy remains high, and this is unlikely to diminish in 2013. The Fed Funds rate will continue to be pegged at 0.25%. Unconventional monetary policy, primarily the expansion of the Fed’s balance sheet to promote employment (Quantitative Easing), will also remain highly stimulative, but for a less certain timeframe. On the other hand, fiscal policy will likely have a negative effect on the economy, with numerous tax provisions expiring and spending cuts expected to be part of the ongoing negotiations. We anticipate the level of fiscal support for the economy to decline this year.

The Federal Reserve is currently on its fourth iteration of Quantitative Easing (QE4), and the latest consensus estimate for the size of the Fed’s balance sheet at the end of 2013 is nearly \$4 trillion (see **Chart 1**). For perspective, at the end of 2012, the Fed’s balance sheet

was valued below \$3 trillion, and prior to the financial crisis it was at less than \$800 billion. This expansion of the Fed’s balance sheet will likely create an inflation problem in the future. Nonetheless, based on the high unemployment rate and the perceived excess capacity within the US economy, the Fed continues to look past the negative implications of a large balance sheet and the monetary stimulus embedded within.

Chart 1

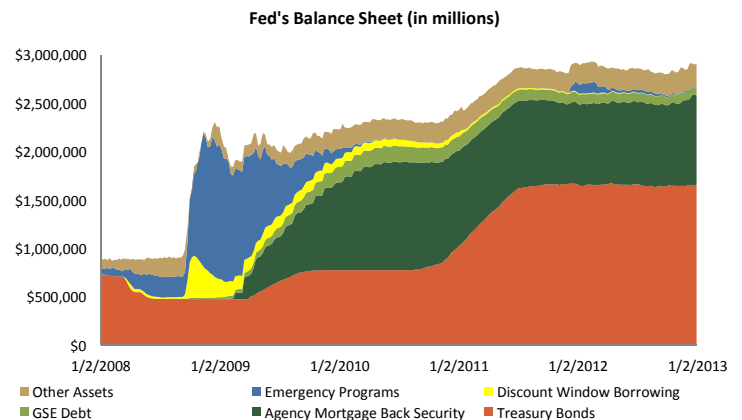

The other potential safe-haven sector in the US, government-sponsored enterprises (GSEs), such as Fannie Mae and Freddie Mac, remain under conservatorship by the US Treasury and are required to shrink their retained portfolios by 15% per year beginning in 2013 (as compared to the previous requirement of 10% per annum). As the supply of GSEs continues to contract, the historically attractive yield enhancement from owning Agencies versus Treasuries will continue to trend downward.

Despite an estimated net Q1-2013 issuance of just over \$500 billion in US Treasuries, the net amount of new Treasury coupon supply (excluding TIPS and T-Bills) available for the market to absorb is far less. Approximately \$300 billion in US Treasuries will mature and the Fed’s QE program anticipates purchases of more than \$130 billion, leaving slightly more than \$60 billion net new supply for the market (as shown in **Chart 2**). Thus, even though the US government continues to accumulate large deficits and continues to fund those deficits through issuance of Treasuries, the impact on the net supply to the market has been negligible. With meager net supply far exceeded by normal market demand, the yield on US Treasuries will likely stay close to its current low levels.

Treasury Debt: How Much is Available for Private Investors? (CONTINUED)

Chart 2

Treasury Coupon Dynamics - 1st Q 2013 (in millions)

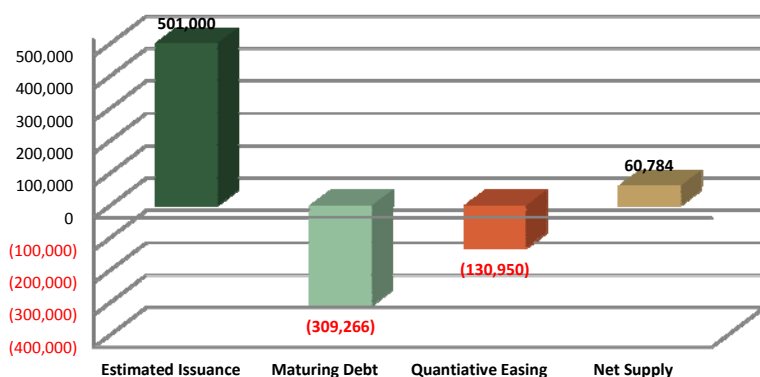

Based on the most recent quarterly projections of the Federal Reserve, the committee's long-term goals for unemployment and inflation are 5.2-6.0% and 2.0%, respectively. The Fed has also communicated it is willing to accept inflation running above its 2.0% target, provided that the unemployment rate remains above 6.5% and long-term inflation expectations remain "anchored". We foresee the FOMC will continue actively distorting asset prices—to the detriment of fixed income investors—by keeping the yield on Treasury securities artificially low (see **Chart 3**).

The current supply of new issues confirms the Fed is disproportionately purchasing Treasury assets further out on the yield curve, where investors typically extract the most concession when inflation expectations increase. **Chart 3** shows that in the 10-30 year maturity range, demand almost equals supply (when taking QE4 into account). The Treasury issuances available to investors are much greater with shorter maturities. With the Fed actively choosing to purchase longer term issues, they are also actively constraining investors' opportunities to take a bearish view on long-term inflation expectations.

Despite the significant amount of quarterly US Treasury issuances, rates are unlikely to increase significantly with the Fed's latest iteration of QE. In conclusion, our analysis of fiscal policy and developments, economic issues, and the Fed's goals, confirm the estimated net quarterly supply of \$60 billion is not nearly enough to alter current market dynamics. Private investors may need to seek out alternative investment vehicles due to a shortage of Agencies and Treasuries.

- William Dennehy II, CFA
Portfolio Manager

Chart 3

Fed is Constraining Supply in Longer Duration Treasury Assets (in millions)
(Estimates of 1st Quarter 2013)

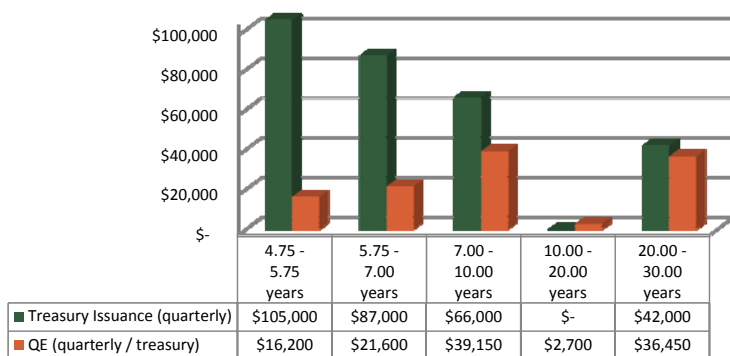

Source for charts: US Treasury and Federal Reserve

RISKS AND OTHER IMPORTANT CONSIDERATIONS

This report is provided for informational purposes only and should not be construed as specific investment or legal advice. The information contained herein was obtained from sources believed to be reliable as of the date of publication, but may become outdated or superseded at any time without notice. Any opinions or views expressed are based on current market conditions and are subject to change. This report may contain forecasts and forward-looking statements which are inherently limited and should not be relied upon as an indicator of future results. Past performance is not indicative of future results. This report is not intended to constitute an offer, solicitation, recommendation or advice regarding any securities or investment strategy and should not be regarded by recipients as a substitute for the exercise of their own judgment.

Fixed income investments are subject to interest, credit, and market risk. Interest rate risk: the value of fixed income investments will decline as interest rates rise. Credit risk: the possibility that the borrower may not be able to repay interest and principal. Low rated bonds generally have to pay higher interest rates to attract investors willing to take on greater risk. Market risk: the bond market in general could decline due to economic conditions and interest rates.

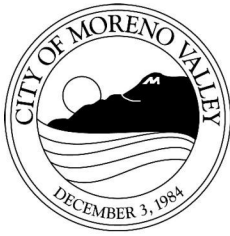

APPROVALS	
BUDGET OFFICER	<i>[Signature]</i>
CITY ATTORNEY	<i>[Signature]</i>
CITY MANAGER	<i>[Signature]</i>

Report to City Council

TO: Mayor and City Council

FROM: Ahmad R. Ansari, P.E., Public Works Director/City Engineer

AGENDA DATE: February 26, 2013

TITLE: APPROVE A RESOLUTION OF THE CITY COUNCIL OF THE CITY OF MORENO VALLEY, CALIFORNIA, TO AMEND THE ELECTRIC RATES FOR MORENO VALLEY UTILITY

RECOMMENDED ACTION

Recommendation:

1. Approve Resolution No. 2013-13 amending the Electric Rates for Moreno Valley Utility – Resolution No. 2013-13 - A Resolution of the City Council of the City of Moreno Valley, California, to Amend the Electric Rates, and Electric Service Rules, Fees, and Charges for Moreno Valley Utility

ADVISORY BOARD/COMMISSION RECOMMENDATION

N/A

BACKGROUND

On July 8, 2003, the City Council approved Resolution No. 2003-58 adopting the Electric Service Rules, Fees and Charges for the City of Moreno Valley's Electric Utility, or Moreno Valley Utility (MVU). Electric Rule 12 entitled "Rates and Optional Rates" of that document states that the rates to be charged by and paid to the City's utility for electric service will be the rates legally in effect and on file with the Electric Utility Division, Department of Public Works. At its meeting on December 9, 2003, the City Council approved Ordinances 650 and 651 providing for the establishment and adjustment of electric rates by resolution.

DISCUSSION

Consistent with Ordinances 650 and 651, the resolution considered in this action amends MVU's Electric Rates. A complete copy of the proposed *Electric Rates* document is available for review in the Public Works Department, Electric Utility Division office. To ensure the City's rates are just and reasonable and to ensure that the City's rates are set at a level sufficient to cover the utility's costs, it will be necessary for the City Council to approve an adjustment of the rates that MVU charges customers for service from time to time. Due to the structure of MVU's rates, the customer's usage will ultimately determine the impact of this proposed rate adjustment on their monthly bill.

For example, the proposed rate adjustment considered in this council action will affect a residential customer who uses 600 kWh in a month differently than a customer who uses 1000 kWh in a month. The proposed rate changes considered in the council action will result in an increase of MVU's rate schedules for both the summer season and winter season. Pursuant to MVU's rates, the summer season begins at 12:00 am on the first Sunday in June and continues until 12:00 am on the first Sunday in October. The winter season begins at 12:00 am on the first Sunday in October, and continues until 12:00 am on the first Sunday in June of the following year. In other words, there are four months in the summer season, and eight months in the winter season.

If the City Council approves the proposed rate adjustments, the impact to each class of customers is described in the tables below:

Average Residential Schedule A	SUMMER		WINTER	
600 kWh usage	\$0.18	0.21%	\$7.21	6.56%
1,000 kWh usage	\$14.45	7.58%	\$23.24	10.02%

Average Small Commercial Schedule B	SUMMER		WINTER	
2,978 kWh usage	\$46.48	6.82%	\$21.16	4.45%

Average Large Commercial Schedule C	SUMMER		WINTER	
24,531 kWh usage, Demand of 100 kW	\$380.87	6.44%	\$105.08	3.01%

Average Large Commercial, TOU Schedule TOU-LGS	SUMMER		WINTER	
	386,896 kWh usage, Demand of 865 kW	\$4,308.56	6.43%	
392,333 kWh usage, Demand of 666 kW			\$727.12	1.97%

Average Traffic Controller Schedule TC-1	SUMMER		WINTER	
	364 kWh usage	\$2.71	4.21%	\$2.71

Average Streetlight	SUMMER		WINTER	
	Schedule SL-1 9,500 Lumen (973 lights)	\$494.33	3.91%	\$494.33
Schedule SL-1 22,000 Lumen (317 lights)	\$174.57	3.24%	\$174.57	3.24%
Schedule SL-2 27,500 Lumen (139 lights)	\$35.00	2.12%	\$35.00	2.12%
Schedule SL-3 (per lamp)	\$27.30	6.20%	\$27.30	6.20%

If approved by the City Council, these changes will become effective at 12:00 a.m. on February 27, 2013.

Pursuant to Section 5 of the Professional Services Agreement by and between the City of Moreno Valley and ENCO Utility Services Moreno Valley, LLC, the City is obligated to adjust its rates from time to time so that the City's electric rates remain roughly equivalent to the otherwise applicable investor owned utility rate schedules. This council action will true-up MVU's rates to comply with this obligation, and comply with State law. If adopted, the net impact upon MVU customers will be an increase in rates.

ALTERNATIVES

1. Approve proposed resolution amending the Electric Rates for Moreno Valley Utility as on file in the Electric Utility Division, Public Works Department. *The amendment of the Electric Rates will allow the City's utility to recover its costs for service, and to offer competitive rates.*
2. Do not approve proposed resolution amending the Electric Rates for Moreno Valley Utility as on file in the Electric Utility Division, Public Works Department. *This would restrict the City's utility in its ability to recover utility costs, and also its ability to offer competitive rates.*

FISCAL IMPACT

As rates are adjusted, revenues will reflect the adjustments. Utility revenues are projected to increase if the proposed changes are adopted by the City Council.

CITY COUNCIL GOALS

REVENUE DIVERSIFICATION AND PRESERVATION:

The municipal electric utility will generate revenues to provide funding for City programs and services over time. These revenues will help achieve important financial goals of the City.

POSITIVE ENVIRONMENT:

The proposed rate adjustments ensures timely changes to the rates of the City’s utility, and helps to create a positive environment for economic development within the community. The City of Moreno Valley will offer competitive rates and will help the City create new jobs.

NOTIFICATION

Posting of the Agenda.

ATTACHMENTS

Attachment 1 – Proposed Resolution
Exhibit A – Proposed Electric Rates

Prepared By:
Jeannette Olko
Electric Utility Division Manager

Department Head Approval:
Ahmad R. Ansari, P.E.
Public Works Director/City Engineer

Council Action	
Approved as requested:	Referred to:
Approved as amended:	For:
Denied:	Continued until:
Other:	Hearing set for:

RESOLUTION NO. 2013-13

A RESOLUTION OF THE CITY COUNCIL OF THE CITY OF MORENO VALLEY, CALIFORNIA, TO AMEND THE ELECTRIC RATES, AND ELECTRIC SERVICE RULES, FEES, AND CHARGES FOR MORENO VALLEY UTILITY

WHEREAS, the City of Moreno Valley (the "City"), a municipal corporation, is authorized pursuant to Article XI, Section 9(a) of the California Constitution to establish, purchase, and operate public works to furnish its inhabitants with light, water, power, heat, transportation, or means of communication; and

WHEREAS, on June 26, 2001, the City Council of the City of Moreno Valley approved Resolution No. 2001-33 and, as amended by Resolution 2002-46, authorized the formation of a municipally owned utility for the purpose of providing electrical power, storm water, telephone telecommunications, cable TV, water, natural gas, and sanitary sewer; and

WHEREAS, on July 8, 2003, the City Council approved Resolution No. 2003-58 adopting the Electric Service Rules, Fees and Charges document for Moreno Valley Utility which states, in part, that the rates to be charged by and paid to the City for electric service will be the rates legally in effect and on file with the City Council; and

WHEREAS, there are sections of the Electric Service Rules, Fees and Charges document that contain rules which define the terms and conditions under which electric service will be provided to the customer; and

WHEREAS, there are rules, fees, charges, and rates associated with providing the services identified in the document. These rules, fees, charges, and rates are deemed necessary and equitable for services rendered and are required to fund in whole or in part, all of the services required to facilitate the delivery of electric distribution pursuant to the rules; and

WHEREAS, Urgency Ordinance No. 651 was adopted by the City Council on December 9, 2003, allowing for the adoption of rates by resolution.

1
Resolution No. 2013-13
Date Adopted: February 26, 2013

NOW, THEREFORE, THE CITY COUNCIL OF THE CITY OF MORENO VALLEY, CALIFORNIA, DOES HEREBY RESOLVE AS FOLLOWS:

1. The City Council hereby adopts the amended Moreno Valley Utility Electric Rates and Electric Service Rules, Fees, and Charges as on file in the Public Works Department and attached hereto as Exhibit A.

APPROVED AND ADOPTED this 26th day of February 2013.

Mayor

ATTEST:

City Clerk

APPROVED AS TO FORM:

City Attorney

Resolution No. 2013-13²
Date Adopted: February 26, 2013

RESOLUTION JURAT

STATE OF CALIFORNIA)
COUNTY OF RIVERSIDE) ss.
CITY OF MORENO VALLEY)

I, Jane Halstead, City Clerk of the City of Moreno Valley, California, do hereby certify that Resolution No. 2013-13 was duly and regularly adopted by the City Council of the City of Moreno Valley at a regular meeting thereof held on the 26th day of February, 2013, by the following vote:

AYES:

NOES:

ABSENT:

ABSTAIN:

(Council Members, Mayor Pro Tem and Mayor)

CITY CLERK

(SEAL)

Resolution No. 2013-13³
Date Adopted: February 26, 2013

This page intentionally left blank.

Moreno Valley Utility
Electric Rates

Electric Rates - Table of Contents

SCHEDULE A – RESIDENTIAL SERVICE.....3

SCHEDULE B – GENERAL SERVICE6

SCHEDULE C – LARGE GENERAL SERVICE.....7

SCHEDULE SL – STREET LIGHTING SERVICE.....10

MVU OWNED SYSTEM.....10

SCHEDULE SL2 – STREET LIGHTING SERVICE.....12

SCHEDULE SL3 – STREET LIGHTING SERVICE.....13

SCHEDULE TC-1 – TRAFFIC CONTROL SERVICE.....14

SCHEDULE TOU-LGS – TIME OF USE – LARGE GENERAL SERVICE.....16

SCHEDULE SE - SERVICE ESTABLISHMENT CHARGE.....19

SCHEDULE NEM – NET ENERGY METERING.....20

SCHEDULE ED – ECONOMIC DEVELOPMENT (“ED”) RATE.....21

SCHEDULE A – RESIDENTIAL SERVICE

Applicability

Applicable to electric service for residential uses.

Territory

Within the designated areas served by the Moreno Valley Utility.

Rates

Basic Charge - \$/Day

Single-Family Residence	\$ 0.03
Multi-Family Residence	\$ 0.023

Energy Usage Charge - \$/kWh

Summer:

Tier 1 -Baseline Quantities, all kWh, per kWh	\$ 0.11494
Tier 2 – 101% to 130% of Baseline	\$ 0.14621
Tier 3 – 131% to 200% of Baseline	\$ 0.27926
Tier 4 – 201% to 300% of Baseline	\$ 0.31426
Tier 5 – All excess kWh, per kWh	\$ 0.34926

Winter

Tier 1 -Baseline Quantities, all kWh, per kWh	\$ 0.11494
Tier 2 – 101% to 130% of Baseline	\$ 0.14621
Tier 3 – 131% to 200% of Baseline	\$ 0.27926
Tier 4 – 201% to 300% of Baseline	\$ 0.31426
Tier 5 – All excess kWh, per kWh	\$ 0.34926

Public Purpose Programs

All kWh per kWh	\$0.01452
-----------------	-----------

Monthly Minimum Charge: \$10.00

Energy Cost Adjustment

1. The energy charge may be adjusted each month based upon the percentage of the energy being provided by the Department of Water Resources to the investor owned utility on the billing date monthly. These adjustments could result in slight decreases or increases in the energy charge.

Special Conditions

1. Baseline Rates: Baseline rates are applicable only to separately metered residential use.
2. Baseline Quantities: The residential allocation shall be 16.0 kWhs per day in the Summer season and 10.5 kWhs per day in the Winter season.
3. Summer and Winter Seasons are defined as follows: The Summer season begins at 12:00 a.m. on the first Sunday in June and will continue until 12:00 a.m. of the first Sunday in October each year. The Winter season begins at 12:00 a.m. on the first Sunday in October and continues until 12:00 a.m. on the first Sunday in June of the following year.
4. Voltage: Service will be supplied at one standard voltage.
5. For the purposes of applying the Basic Charge, the following definitions shall be used:

Single-Family Residence - A building of single occupancy which does not share common walls, floors, or ceilings with other residential dwelling units.

Multi-Family Residence - Apartments, mobile homes, condominiums, townhouses, or a building of multiple occupancy which shares common walls and /or floors and ceilings with other residential dwelling units.

6. Medical Baseline Allocation: Upon application and acceptance of a certification from a medical doctor or osteopath licensed to practice medicine in California, eligible residential customers are provided a standard year-round medical baseline allocation of 16.5 kWh per day in addition to the applicable baseline allocation for the season.

	Regular Baseline Daily kWh Allocation	Additional Medical Baseline Daily kWh Allocation	Total Baseline Daily kWh Allocation
Summer	16.0	16.5	32.5
Winter	10.5	16.5	27.0

Medical Baseline Allocation Eligibility:

- a) Regular use in the customer's home of one or more medical life-support devices essential to maintain the life of a full-time resident of the household; and/or

-
- b) A full-time resident of the household is: a paraplegic, hemiplegic, quadriplegic, multiple sclerosis or scleroderma patient, being treated for life-threatening illness, and/or has a compromised immune system.

Life support devices are those devices or equipment that utilize mechanical or artificial means to sustain, restore or supplant a vital function, or mechanical equipment relied upon for mobility both within and outside of buildings.

Life-support devices include:

Aerosol Tent	Ultrasonic Nebulizer
Pressure Pad	Electrostatic Nebulizer
Apnea Monitor	Inhalation Pulmonary Pressure
Pressure Pump	Breather Machine (IPPB)
Compressor	Iron Lung
Concentrator	Dialysis Machine
Respirator (all types)	Hemodialysis Machine
Electronic Nerve Stimulator	Motorized Wheelchair
Suction Machine	Oxygen Generator

Applying for the Medical Baseline Allocation

1. Request application from Moreno Valley Utility by telephone, mail or in person
 2. Complete application.
 3. The patient's physician will need to fill out the required information on the application and sign it certifying the medical need.
 4. The customer can mail or bring the application to Moreno Valley Utility's offices
 5. Once the application is reviewed and approved, the Medical Baseline Allocation will be effective on the next regular electric billing.
 6. Applications must be renewed every two years.
7. Low Income Program - A low-income assistance discount program is offered under this standard residential rate. To be considered for this discount, an application must be filed with Moreno Valley Utility. To be eligible for this discount, the income of the customer, including all members of the household, must meet the income levels of the program and can be no more than 200% of Federal Poverty Guidelines. Under this program a discount for qualified low-income residents of 20% is provided on monthly energy charges. Discount applies to energy charges only. The customer charge, public purpose charge, service fees and all taxes are calculated at the standard rates.

SCHEDULE B – GENERAL SERVICE

Applicability

Applicable to nonresidential electric service for all types of uses including lighting and power. Customers whose monthly maximum demand is expected to exceed 20 kW, or has exceeded 20 kW in any three months during the preceding 12 months, are ineligible for service under this schedule.

Territory

Within the designated areas served by the Moreno Valley Utility.

Rates

Customer Charge - \$/Day

Single-Phase Service	\$ 0.796
Polyphase Service	\$ 0.035

Energy Usage Charge - \$/kWh

Summer, all kWh, per kWh	\$ 0.19523
Winter, all kWh, per kWh	\$ 0.12982

Public Purpose Programs

All kWh per kWh	\$0.01262
-----------------	-----------

Monthly Minimum Charge:

\$10.00

Energy Cost Adjustment

1. The energy charge may be adjusted each month based upon the percentage of the energy being provided by the Department of Water Resources to the investor owned utility on the billing date monthly. These adjustments could result in slight decreases or increases in the energy charge.

Special Conditions

1. Summer and Winter Seasons are defined as follows: The Summer season begins at 12:00 a.m. on the first Sunday in June and will continue until 12:00 a.m. on the first Sunday in October each year. The Winter season begins at 12:00 a.m. on the first Sunday in October and continues until 12:00 a.m. on the first Sunday in June of the following year.
2. Voltage: Service will be supplied at one standard voltage.

SCHEDULE C – LARGE GENERAL SERVICE

Applicability

Applicable to nonresidential electric service for all types of uses including lighting and power where the customer's monthly maximum demand is expected to exceed 20 kW or has exceeded 20 kW in any of the 3 months during the preceding 12 months.

Territory

Within the designated areas served by the Moreno Valley Utility.

Rates

Customer Charge - \$/Meter/Month – Single Phase	\$132.67	
Polyphase	\$145.63	
Energy Usage Charge - \$/kWh		
Summer, all kWh, per kWh	\$ 0.07790	
Winter, all kWh, per kWh	\$ 0.06011	
Demand Charge- \$/kW	<u>Summer</u>	<u>Winter</u>
Facilities Related Demand Charge, per kW	\$13.94	\$13.94
Time Related Demand Charge, per kW	\$18.48	\$0.00
Public Purpose Programs		
All kWh per kWh	\$ 0.01159	
Monthly Minimum:	\$10.00	

Energy Cost Adjustment

1. The energy charge may be adjusted each month based upon the percentage of the energy being provided by the Department of Water Resources to the investor owned utility on the billing date monthly. These adjustments could result in slight decreases or increases in the energy charge.

Special Conditions

1. Summer and Winter Seasons are defined as follows:

The Summer season begins at 12:00 a.m. on the first Sunday in June and will continue until 12:00 a.m. on the first Sunday in October of each year. The Winter season begins at 12:00 a.m. on the first Sunday in October and continue until 12:00 a.m. on the first Sunday in June of the following year.

2. Voltage: Service will be supplied at one standard voltage.
3. Billing Demand: The Billing Demand shall be the kilowatts of Maximum Demand, determined to the nearest kW. The Billing Demand shall be the greater of the kilowatts of Maximum Demand recorded (or established for) the monthly billing period or 50% of the highest Maximum Demand established in the preceding eleven months (Ratcheted Demand).
4. Maximum Demand: The maximum demand in any month shall be the measured maximum average kilowatt input, indicated or recorded by instruments to be supplied by the City, during any 15-minute metered interval in the month.
5. Voltage Discount: The monthly Facilities Related Demand Charge will be reduced by 23.3% for service delivered and metered at voltages of 4 kV through 12 kV. The energy charge will be reduced by \$.00074 per kWh for service delivered and metered at voltages of 2 kV through 12 kV.
6. Excess Transformer Capacity: Excess Transformer Capacity is the amount of transformer capacity requested by a customer in excess of that which the City would normally install to serve the customer's Maximum Demand. Excess Transformer Capacity shall be billed at the amount shown in the rates section above.
7. Power Factor Adjustment: When Maximum Demand has exceeded 200 kW for three consecutive months, kilovar metering will be installed as soon as practical, and thereafter, until the Maximum Demand has been less than 150 kW for twelve consecutive months, the billing will be adjusted each month for power factor.
 - a. Adjustment Rate:
 - i. For service delivered and metered at voltages 12 kV or less, the billing will be increased by \$0.27 per kilovar of maximum reactive demand.
 - b. Determining the Reactive Demand:
 - i. Service delivered and metered at voltages of 4 kV or greater:
 1. The maximum reactive demand shall be the highest measured maximum average kilovar demand indicated or

recorded by metering during any 15-minute metered interval in the month. The kilovars shall be determined to the nearest unit. A device will be installed on each kilovar meter to prevent reverse operation of the meter.

- ii. Services delivered and metered at voltages less than 4 kV:
 - 1. For customers with metering used for billing that measures reactive demand, the maximum reactive demand shall be the highest measured maximum average kilovar demand indicated or recorded by metering during any 15-minute metered interval in the month. The kilovars shall be determined to the nearest unit. A device will be installed on each kilovar meter to prevent reverse operation of the meter.
 - 2. For customers with metering used for billing that measures kilovar-hours instead of reactive demand, the kilovars of reactive demand shall be calculated by multiplying the kilowatts of measured maximum demand by the ratio of the kilovar-hours to the kilowatt-hours. Demands in kilowatts and kilovars shall be determined to the nearest unit. A ratchet device will be installed on the kilovar-hour meter to prevent its reverse operation on leading power factors.

SCHEDULE SL – STREET LIGHTING SERVICE

MVU OWNED SYSTEM

Applicability

Applicable to un-metered service for the lighting of streets and highways where MVU owns and maintains the street lighting equipment and associated facilities included under this schedule.

Territory

Within the designated areas served by the Moreno Valley Utility.

Rates

Energy Usage Charge - High Pressure Sodium Vapor Lamps

Basic Charge:

<u>Initial Lumens</u>	<u>Wattage</u>	<u>All Night Service Monthly kWhs</u>	<u>\$/Lamp Monthly Charge</u>	<u>\$/Lamp/Month Public Purpose Programs Charge</u>
9,500	100	40	\$12.54	\$0.20
16,000	150	67	\$14.30	\$0.32
22,000	200	85	\$16.17	\$0.41
27,500	250	108	\$17.81	\$0.53

Energy Usage Charge – Light Emitting Diode (LED) Lamps

Basic Charge:

<u>Initial Lumens</u>	<u>Wattage</u>	<u>All Night Service Monthly kWhs</u>	<u>\$/Lamp Monthly Charge</u>	<u>\$/Lamp/Month Public Purpose Programs Charge</u>
14,700	173	75	19.53	\$0.37

Energy Cost Adjustment

1. The energy charge may be adjusted each month based upon the percentage of the energy being provided by the Department of Water Resources to the investor owned utility on the billing date monthly. These adjustments could result in slight decreases or increases in the energy charge.

Special Conditions

1. Maintenance shall include periodic inspection, renewal of lamps, cleaning of glassware, replacement of damaged glassware and lamps, and minor repairs to wiring and electrical appurtenances.
2. Hours of Service: Under MVU's standard all night operating schedule, approximately 4,140 hours of service will be furnished.
3. The developer shall install streetlights that will be served from MVU's underground system. These streetlights must be installed in accordance with MVU's specifications and the developer will deed such facilities to MVU.
4. Requirements and Restrictions:
 - a. The applicant for street light service shall specify the lamp size and location of streetlights.
 - b. Service shall not be furnished under this schedule where location, mounting height, or other considerations are unacceptable to the MVU.
 - c. The installation of street lighting equipment and facilities hereunder is contingent upon the MVU obtaining easements, rights of way, and highway permits satisfactory to the MVU for the required poles, equipment, and facilities.
 - d. In accordance with Rule No. 4, a written contract for a term of not less than one year is required in order to receive street light service under the provisions of this schedule.
 - e. Should the applicant not commence using the street lighting in a bona fide manner within ninety (90) days after date of completion and installation of a street light or street lighting system requested by the applicant, the MVU will bill, and the applicant shall pay, the applicable lamp charge(s).
5. Liability of Utility: MVU shall not, by taking action pursuant to its tariffs, be liable for any loss, damage, or injury, established or alleged, which may result, or be claimed to result, therefrom.

**SCHEDULE SL2 – STREET LIGHTING SERVICE
CUSTOMER OWNED AND MAINTAINED SYSTEM SCHEDULE
(UNMETERED)**

Applicability

Applicable to service for un-metered lighting of streets, highways, and directional highway signs served in conjunction with street and highway lighting, and other publicly operated automobile parking lots which are open to the general public, where the customer owns and maintains the street lighting equipment operated within the period from dusk to dawn.

Territory

Within the designated areas served by the Moreno Valley Utility.

Rates

Energy Usage Charge - High Pressure Sodium Vapor Lamps

Basic Charge:

<u>Initial Lumens</u>	<u>Wattage</u>	<u>All Night Service Monthly kWhs</u>	<u>\$/Lamp Monthly Charge</u>	<u>\$/Lamp/Month Public Purpose Programs Charge</u>
9,500	100	40	\$ 7.02	\$0.20
16,000	150	67	\$ 8.78	\$0.32
22,000	200	85	\$ 10.00	\$0.41
27,500	250	108	\$ 11.55	\$0.53

Energy Cost Adjustment

1. The energy charge may be adjusted each month based upon the percentage of the energy being provided by the Department of Water Resources to the investor owned utility on the billing date monthly. These adjustments could result in slight decreases or increases in the energy charge.

Special Conditions

1. Voltage: Service will be supplied at one standard voltage.

2. Requirements and Restrictions:

- a. The applicant for street light service shall specify the lamp size and location of streetlights.
- b. Service shall not be furnished under this schedule where location, mounting height, or other considerations are unacceptable to the MVU.
- c. The installation of street lighting equipment and facilities hereunder is contingent upon the MVU obtaining easements, rights of way, and highway permits satisfactory to the MVU for the required poles, equipment, and facilities.

3. Liability of Utility: MVU shall not, by taking action pursuant to its tariffs, be liable for any loss, damage, or injury, established or alleged, which may result, or be claimed to result, therefrom.

**SCHEDULE SL3 – STREET LIGHTING SERVICE
CUSTOMER OWNED SYSTEM SCHEDULE
(METERED)**

Applicability

Applicable to service for metered lighting service of streets, highways, and directional highway signs served in conjunction with street and highway lighting, and other publicly operated automobile parking lots which are open to the general public, where the customer owns the street lighting equipment operated within the period from dusk to dawn.

Territory

Within the designated areas served by the Moreno Valley Utility.

Rates

Customer Charge – Per meter per Month	\$15.36
Energy Usage Charge - \$/kWh	
All Year - all kWh, per kWh	\$ 0.05877
Public Purpose Programs	
All kWh, per kWh	\$0.00488

13

**Proposed by the Moreno Valley Utility
Date Adopted: February 26, 2013**

Energy Cost Adjustment

1. The energy charge may be adjusted each month based upon the percentage of the energy being provided by the Department of Water Resources to the investor owned utility on the billing date monthly. These adjustments could result in slight decreases or increases in the energy charge.

Special Conditions

1. Voltage: Service will be supplied at one standard voltage.
2. The customer will furnish and maintain all equipment beyond the meter.

SCHEDULE TC-1 – TRAFFIC CONTROL SERVICE

Applicability

Applicable to service for traffic directional sign or signal lighting service owned by governmental agencies and located on streets, highways and other publicly dedicated outdoor ways and places.

Territory

Within the designated areas served by the Moreno Valley Utility.

Rates

Customer Charge – per Meter per Day

Single-Phase Service	\$ 0.563
Polyphase Service	\$ 0.035

Energy Usage Charge - \$/kWh

All Year - all kWh, per kWh	\$ 0.10769
-----------------------------	------------

Public Purpose Programs

All kWh, per kWh	\$0.01166
------------------	-----------

Energy Cost Adjustment

1. The energy charge may be adjusted each month based upon the percentage of the energy being provided by the Department of Water Resources to the investor owned utility on the billing date monthly. These adjustments could result in slight decreases or increases in the energy charge.

Special Conditions

1. Voltage: Service will be supplied at one standard voltage.

SCHEDULE TOU-LGS – TIME OF USE – LARGE GENERAL SERVICE

Applicability

Applicable to nonresidential electric service for all types of uses including lighting and power where the customer’s monthly maximum demand is expected to exceed 500 kW or has exceeded 500 kW in any of the 3 months during the preceding 12 months.

Territory

Within the designated areas served by the Moreno Valley Utility.

Rates

Customer Charge - \$/Meter/Month	\$625.52	
Energy Usage Charge - \$/kWh		
Summer		
On-Peak	\$ 0.14010	
Mid-Peak	\$ 0.08478	
Off-Peak	\$ 0.05033	
Winter		
Mid-Peak	\$ 0.07347	
Off-Peak	\$ 0.04655	
Demand Charge- \$/kW		
Facilities Related Demand Charge, per kW	<u>Summer</u>	<u>Winter</u>
	\$14.53	\$14.53
Time Related Demand Charge, per kW		
On-Peak	\$17.31	\$0.00
Mid-Peak	\$4.87	\$0.00
Off-Peak	\$0.00	\$0.00
Public Purpose Programs		
All kWh per kWh	\$ 0.01048	
Monthly Minimum :	See Condition #4	

Energy Cost Adjustment

1. The energy charge may be adjusted each month based upon the percentage of the energy being provided by the Department of Water Resources to the investor owned utility on the billing date monthly. These adjustments could result in slight decreases or increases in the energy charge.

Special Conditions

1. Time periods are defined as follows:

On-Peak:	Noon to 6:00 p.m. Summer weekdays except holidays
Mid-Peak:	8:00 a.m. to Noon and 6:00 p.m. to 11 p.m. Summer weekdays except holidays; 8 a.m. to 9 p.m. Winter weekdays except holidays
Off-Peak:	All other hours

Holidays are defined as New Year's Day (January 1), Martin Luther King's Birthday (third Monday in January), Washington's Birthday (third Monday in February), Memorial Day (last Monday in May), Independence Day (July 4), Labor Day (first Monday in September), Veterans Day (November 11), Thanksgiving Day (fourth Thursday in November), and Christmas Day (December 25).

When any holiday listed above falls on Sunday, the following Monday will be recognized as an off-peak period. No change will be made for holidays falling on Saturday.

2. Summer and Winter Seasons are defined as follows: The Summer season begins at 12:00 a.m. on the first Sunday in June and will continue until 12:00 a.m. on the first Sunday in October of each year. The Winter season begins at 12:00 a.m. on the first Sunday in October and continue until 12:00 a.m. on the first Sunday in June of the following year.
3. Voltage: Service will be supplied at one standard voltage.
4. Billing Demand: The Billing Demand shall be the kilowatts of Maximum Demand, determined to the nearest kW. The Billing Demand shall be the greater of the kilowatts of Maximum Demand recorded (or established for) the monthly billing period or 50% of the highest Maximum Demand established in the preceding eleven months (Ratcheted Demand).

-
5. **Maximum Demand:** The maximum demand in any month shall be the measured maximum average kilowatt input, indicated or recorded by instruments to be supplied by the City, during any 15-minute metered interval in the month.
 6. **Excess Transformer Capacity:** Transformer Capacity is the amount of transformer capacity requested by a customer in excess of that which the City would normally install to serve the customer's Maximum Demand. Excess Transformer Capacity shall be billed at the amount shown in the rates section above.
 7. **Power Factor Adjustment:** The billing will be adjusted each month for power factor.
 - a. **Adjustment Rate:** The customer's bill will be increased each month for the power factor \$0.27 per kilovar of maximum reactive demand.
 - b. The maximum reactive demand shall be the highest measured maximum average kilovar demand indicated or recorded by metering during any 15 minute metered interval in the month. For customers with metering used for billing that measures kilovar-hours instead of reactive demand, the kilovars of reactive demand shall be calculated by multiplying the kilowatts of measured maximum demand by the ratio of the kilovar-hours to the kilowatt-hours. Demands in kilowatts and kilovars shall be determined to the nearest unit. A device will be installed on the kilovar-hour meter to prevent its reverse operation on leading power factors.

SCHEDULE SE - SERVICE ESTABLISHMENT CHARGE

Applicability

Applicable to general service and domestic service customers.

Territory

Within the entire territory served by Moreno Valley Utility.

Rate

For each establishment of electric service, a charge will apply.

Special Conditions

1. The service establishment charge is in addition to the charges calculated on the applicable rate schedule and will be made each time an account is established.
2. Establishment means each time an account is opened, including a turn on of electric service or a change of name that requires a meter reading.
3. If the customer requests electric service be established on the same day as his request or outside regular business hours, an additional charge will apply.

SCHEDULE NEM – NET ENERGY METERING

Applicability

Applicable to general service and domestic service customers who have eligible renewable energy generation systems connected to MVU's system (interconnected) and meet program requirements.

Territory

Within the entire territory served by Moreno Valley Utility.

Net Surplus Compensation Rate

The net surplus compensation rate shall be \$0.08979 per kWh applied to any net surplus energy remaining at the end of the customer's twelve (12) month billing period ("relevant period").

Special Conditions

1. NEM customers will receive a credit for the surplus electricity supplied to MVU's system.
2. This credit will be applied to the customer's energy bill, to offset all or part of the costs associated with the energy that is consumed each month.
3. Residential accounts are billed once a year for "net" energy consumed or generated over the previous 12 months, if any.
4. Small business accounts served under the General Service Rate also qualify for annual billing.
5. Large business NEM accounts under the Large General Service Rate are billed monthly for their energy usage.
6. Net surplus energy is the amount of generated kilowatt-hours (kWh) energy that is exported to MVU's system that exceeds the amount that is received from MVU.
7. Any net surplus energy remaining at the end of the 12-month billing period (also called the "relevant period") will be given a monetary value known as the Net Surplus Compensation Rate (NSCR).
8. The NSCR value is established by MVU to reflect the costs MVU avoids in procuring power during the time period net surplus generators are likely to produce excess power.
9. Customers may choose to either roll over the monetary value of any net surplus energy to the next billing cycle, or receive payment for any net surplus energy at the end of your 12-month relevant period.
10. Customers will be billed monthly for nominal non-energy-related charges such as taxes.

SCHEDULE ED – ECONOMIC DEVELOPMENT (“ED”) RATE

Applicability

Commercial or industrial end-use customers that would otherwise receive service under Electric Rate Schedule TOU-LGS (Time of Use-Large General Service) and meet certain criteria as established and adopted by resolution of the City Council of the City of Moreno Valley may take advantage of the ED rate as a New Customer or Expanded Load Customer. This ED rate is applicable to all or part of the services provided to New Customers and Expanded Load Customers, as such terms are defined herein.

1. A New Customer shall be a customer seeking to locate a new business or relocate an existing business (not currently located within the territory served by Moreno Valley Utility) within Moreno Valley Utility’s service territory.
2. An Expanded Load Customer shall be an existing Moreno Valley Utility TOU-LGS customer that is adding new load to Moreno Valley by a minimum of 200 kW based upon the customer’s past electrical demand as determined by Moreno Valley Utility. The expanded load can be at the customer’s current site, or at a new site within the Moreno Valley Utility service territory. The ED rate will only be applied to the expanded load as determined in Section 5 below.
3. A New Customer shall meet the following criteria:
 - a. Targeted industries
 - i. Logistics/Distribution
 - ii. Medical/Healthcare
 - iii. Auto Dealerships
 - b. Building/Area size
 - i. Logistics/Distribution 500,000 sf minimum
 - ii. Medical/Healthcare 100,000 sf minimum
 - iii. Auto Dealerships 5 acres
 - c. Job Creation
 - i. Tier 1 Discount Rate 150 – 499 jobs
 - ii. Tier 2 Discount Rate 500 – 999 jobs
 - iii. Tier 3 Discount Rate greater than 1000 jobs
 - iv. Tier 4 Discount Rate 350 jobs minimum
 - d. City Revenue Producer – either sales tax or use tax generation
 - i. Tier 1a Discount Rate
 - ii. Tier 4 Discount Rate \$40,000 annual minimum to the City

Territory

Within the entire territory served by the Moreno Valley Utility.

Character of Service

The service provided hereunder shall be alternating current with regulated frequency of 60 hertz, three-phase, or a combination single and three-phase served through one meter, at a standard voltage not to exceed 480 volts, or as may be specified by the Electric Division. To be eligible to participate all customers must have a demand meter.

Rates

Except as provided herein, or in the Economic Development Rate Agreement, all charges and provisions of the customer’s otherwise applicable rate schedule shall apply. The applicable Energy Charge and Demand Charge under the customer’s otherwise applicable rate schedule will be reduced as follows:

	Tier 1/Tier 1a	Tier 2	Tier 3	Tier 4
Years 1 - 2	15%	20%	20%	20%
Years 3 - 4	12%	15%	20%	20%
Years 5 – 6	10%	10%	15%	20%
Years 7 -12	-	-	-	20%

Special Conditions

1. Term: Economic Development Rate Agreements entered into under this Schedule shall be for a single six-year term, except for Tier 4, which shall be for a single twelve-year term.
2. Approval: Application of this Rate Schedule shall be subject to the approval of the City Manager or his designee, based on meeting the eligibility criteria outlined herein.
3. Agreement: The customer must sign a standard Moreno Valley Economic Development Rate Agreement in order for the rates under this Schedule to be applicable. In addition to the other terms of this Schedule, the Economic Development Rate Agreement shall require the customer to reimburse Moreno Valley for all rate reductions received under this Schedule, if the customer fails to maintain the required minimum load during the six-year term or twelve-year term of the Agreement.
4. Minimum Load: Customers qualifying under this Schedule as a New Customer with a projected minimum monthly electric demand of at least 500

kW or as an Expanded Load Customer under Applicability Sections 1 and 2 above, respectively, must agree to maintain a minimum level of load for six years for Tier 1/1a, Tier 2, and Tier 3 discounts, and twelve years for Tier 4 discount from the date service is first rendered under this Schedule as set forth in the Economic Development Rate Agreement.

5. Base Period Usage: Base Period Usage shall be established and agreed to in the Economic Development Rate Agreement for Expanded Load Customers. Base Period Usage shall be the average monthly energy use and demand for the customer during the last three years of service to the customer, from the date ending the last payment period before the date of the Agreement. Expanded Load qualifying for the rate under this Schedule shall be measured as the difference between the new monthly, meter documented energy use and demand, and the Base Period Usage.
6. State Mandated Public Purpose Program Charge: All bills rendered under this Schedule shall be subject to the Public Purpose Program Charge as established by the City Council.
7. Miscellaneous Fees and Charges: Rates charged pursuant to this Schedule shall be subject to any Energy Users Taxes, Utility Users Taxes, and any other governmental taxes, duties, or fees which are applicable to Electric Service provided to Customer by the City of Moreno Valley. Rates are also subject to adjustment, as established by the City of Moreno Valley City Council in response to federal or state climate change laws, renewable portfolio standard or other mandated legislation. These adjustments may include but are not limited to charges to mitigate the impacts of greenhouse gas emissions or “green power” premiums.
8. Expanded Load: Expanded Load customers applying for this rate must demonstrate to the satisfaction of the Utility that the expanded load is new to Moreno Valley.
9. Effective Date: The effective date of the Economic Development Rate Agreement shall commence within 12 months from the date of the City’s approval, or the Agreement becomes null and void. The Agreement becomes effective upon execution by the parties, and the Economic Development Rate commences upon written notice by customer, and coincides with the customer’s normal billing cycle.
10. Reapplication: Customers who have received service under the Economic Development Rate are eligible to reapply for the rate as an Expanded Load Customer 12 months after their current Economic Development Rate Agreement has expired, if they meet the criteria therefore.

-
11. Restrictions: Residential customers and federal, state or local government agencies are not eligible to apply for service under this Schedule.



APPROVALS	
BUDGET OFFICER	<i>[Signature]</i>
CITY ATTORNEY	<i>[Signature]</i>
CITY MANAGER	<i>[Signature]</i>

Report to City Council

TO: Mayor and City Council

FROM: Ahmad R. Ansari, P.E., Public Works Director / City Engineer

AGENDA DATE: February 26, 2013

TITLE: APPROVE REIMBURSEMENT AGREEMENT FOR CONSTRUCTION OF ALTERNATE STREET SECTION OVER EASTERN MUNICIPAL WATER DISTRICT (EMWD) FACILITIES AS PART OF THE PERRIS BOULEVARD WIDENING FROM PERRIS VALLEY STORM DRAIN LATERAL "B" TO CACTUS AVENUE
PROJECT NO. 801 0022 70 77

RECOMMENDED ACTION

Recommendations:

1. Approve the Reimbursement Agreement for Construction of an Alternate Street Section over Eastern Municipal Water District (EMWD) Facilities as part of the Perris Boulevard Widening from Perris Valley Storm Drain Lateral "B" to Cactus Avenue.
2. Authorize the City Manager to execute the Reimbursement Agreement for the amount of \$220,000, upon concurrence by EMWD.
3. Authorize the Public Works Director/City Engineer to execute any subsequent related amendments to the Agreement with EMWD up to, but not exceeding an additional amount of \$44,000.
4. Authorize a revenue appropriation of the amount of the EMWD reimbursement in Fund 3003 (TUMF Capital Projects) after the revenue is received from EMWD per the Reimbursement Agreement to fund the alternate street section segment construction.

ADVISORY BOARD/COMMISSION RECOMMENDATION

“N/A.”

BACKGROUND

City Council approved the construction contract in the amount of \$3,282,680.11 with Hillcrest Contracting, Inc. (Hillcrest) on June 12, 2012. At this same meeting, City Council authorized the Public Works Director/City Engineer to execute any Contract Change Orders up to, but not exceeding, the 20% contingency amount of \$656,536.02. Construction for this project started in July 2012 and is estimated for completion in April 2013.

DISCUSSION

Perris Boulevard is an existing partially improved north/south arterial street between the limits of Perris Valley Storm Drain Lateral “B” (Southerly City Limits) and Cactus Avenue in the City of Moreno Valley. The existing improvements, which vary in width, consist of a two-lane road with shoulders in some areas to other areas that are fully built out. This project is to widen and improve Perris Boulevard within the project limits to an arterial street standard with a curb-to-curb width of 86 feet (86’) within a 110 feet (110’) right of way. To date, curb, gutter, sidewalk, traffic signal modifications, and utility relocations have been significantly completed. Improvements still to be constructed include paving, signing and striping, and related road improvements.

During construction, EMWD requested the City to construct an alternate street section over their existing 33 inch and 39 inch EMWD waterlines at the following locations in order to ensure the structural integrity of their waterline during the street construction:

- Perris Boulevard South of Suburban Lane
- Perris Boulevard from Northern Dancer Drive to Krameria Avenue
- Perris Boulevard South of Santiago Drive
- Perris Boulevard South of Gention Avenue
- Perris Boulevard North of Gention Avenue
- Perris Boulevard from Delphinium Avenue to Cactus Avenue

The work at the above locations includes construction of an alternate street section above and adjacent to the EMWD Facilities in order to avoid compaction directly above them. This additional work includes installation of controlled low-strength material (CLSM), additional roadway excavation, and additional asphalt concrete.

Hillcrest, the City’s contractor for the project, will complete the work as a change order to their existing contract for the Perris Boulevard Widening project. The City would pay Hillcrest for the construction costs, estimated at \$220,000, per an executed contract change order. The estimated costs and 20% contingency of the City/EMWD Reimbursement Agreement are within the approved contingency threshold of the City’s Contract with Hillcrest. EMWD will reimburse the City for these costs per the terms of

the City/EMWD Reimbursement Agreement. EMWD shall be solely responsible for costs associated with the additional work. EMWD agrees to pay the construction and construction related costs and in the event that the final quantities are either higher or lower than estimated, the City will provide a final cost summary to EMWD, and they shall bear full financial responsibility for all costs associated with the work.

EMWD approved the Reimbursement Agreement at its Board of Directors meeting on February 6, 2013.

ALTERNATIVES

1. By motion authorize the recommended actions as presented in this staff report. *This action will allow for EMWD facilities to be protected in place without delays to the construction schedule and at EMWD's expense.*
2. Do not authorize the recommended actions as presented in this staff report. *This action may cause EMWD facilities to be damaged during construction, which could result in additional costs to the City and potential delays to the construction schedule.*

FISCAL IMPACT

If the Reimbursement Agreement is approved, Hillcrest would complete the work under a change order to their existing contract with the City for the project. The City would pay Hillcrest for the construction costs, estimated at \$220,000, per the executed contract change order. The estimated costs and 20% contingency of the City/EMWD Reimbursement Agreement are within the approved contingency threshold of the City's Contract with Hillcrest. EMWD will reimburse the City for these costs per the terms of the City-EMWD Reimbursement Agreement.

The costs associated with the Reimbursement Agreement will be fully reimbursed by EMWD and will not affect the project budget. Per the terms of the Reimbursement Agreement, upon completion of the additional construction and determination of the final costs, EMWD will make a payment to the City within 30 days following the City's notification of the actual costs.

In order to responsibly track the Reimbursement Agreement funds, a revenue appropriation of the EMWD reimbursement amount plus contingency would be established in Fund 3003 (TUMF Capital Projects), as indicated below.

Budget Appropriation

Cat.	Fund	Project No. (PN) G/L Account (GL)	Type	Original Budget	Proposed Adjustment	Revised Budget
CIP	TUMF Capital Projects (3003)	Acct. No. 3003-99-99- 80001-500600	REV	\$0	\$264,000	\$264,000

AVAILABLE EXPENDITURE FUNDS:

Available Budgeted TUMF Funds Perris Boulevard Widening / Perris Valley Storm Drain Lateral "B" to Cactus Avenue (Acct. No. 3003-70-77-80001 / Project No. 801 0022 70 77)	\$5,665,000
Available Budgeted DIF Funds Perris Boulevard Widening / Perris Valley Storm Drain Lateral "B" to Cactus Avenue (Acct. No. 3301-70-77-80001 / Project No. 801 0022 70 77)	<u>\$80,000</u>
Available and Proposed Expenditure Funds	<u>\$5,745,000</u>

ESTIMATED CONSTRUCTION RELATED COSTS:

Design Support Services during Construction	\$161,000
Contractor Construction Costs (includes 20% contingency).....	\$3,940,000
EMWD Alternate Street Section	\$264,000
Reimbursement from EMWD for Alternate Street Section.....	(\$264,000)
Construction Geotechnical Services.....	\$109,000
Construction Survey Services	\$129,000
Project Management and City Inspection.....	\$220,000
Administrative and Miscellaneous	<u>\$100,000</u>
Total Estimated Construction Related Costs	<u>\$4,659,000</u>

ANTICIPATED SCHEDULE:

Advertise / Bid / Award	April 2012 to June 2012
Construction	July 2012 to April 2013

CITY COUNCIL GOALS

POSITIVE ENVIRONMENT:

Create a positive environment for the development of Moreno Valley's future.

PUBLIC FACILITIES AND CAPITAL PROJECTS:

Ensure that needed public facilities, roadway improvements, and other infrastructure improvements are constructed and maintained.

SUMMARY

During construction, EMWD requested the City to construct an alternate street section over their existing 33 inch and 39 inch EMWD waterlines at the various locations in order to ensure their structural integrity during the street construction. The Reimbursement Agreement provides for the terms and responsibilities of the proposed additional work. EMWD shall be solely responsible for the costs associated with the additional work. Staff recommends that City Council approve the Reimbursement Agreement and authorize the City Manager to execute said Reimbursement Agreement.

NOTIFICATION

None

ATTACHMENTS

Attachment 1 - Reimbursement Agreement for Construction of an Alternate Street Section over Eastern Municipal Water District (EMWD) Facilities

Prepared By:
Lorenz R. Gonzales
Senior Engineer, P.E.

Department Head Approval:
Ahmad R. Ansari, P.E.
Public Works Director / City Engineer

Concurred By:
Prem Kumar, P.E.
Deputy Public Works Director / Assistant City Engineer

Council Action	
Approved as requested:	Referred to:
Approved as amended:	For:
Denied:	Continued until:
Other:	Hearing set for:

This page intentionally left blank.

REIMBURSEMENT AGREEMENT

FOR CONSTRUCTION OF AN ALTERNATE STREET SECTION OVER EASTERN MUNICIPAL WATER DISTRICT (EMWD) FACILITIES AS A PART OF THE PERRIS BOULEVARD WIDENING FROM PERRIS VALLEY STORM DRAIN LATERAL "B" TO CACTUS AVENUE PROJECT NO. 801 0022 70 77 BY THE CITY OF MORENO VALLEY

This Agreement is made and entered into as of the date signed by the City Manager and Executive Director, by and between EASTERN MUNICIPAL WATER DISTRICT, a public agency (hereinafter "District"), and the CITY OF MORENO VALLEY, a municipal corporation (hereinafter "City").

RECITALS

WHEREAS, construction has commenced for the Perris Boulevard Widening from Perris Valley Storm Drain Lateral "B" to Cactus Avenue, Project No. 801 0022 70 77, by the City of Moreno Valley herein after referred to as "City Project."

These improvements are in the City of Moreno Valley, and

WHEREAS, during construction, it was discovered that 33 inch and 39 inch District waterlines (hereinafter "District Facilities") at the following locations are aging and, at the request of the District, required an alternate street section in order to protect the District Facilities in place:

- Perris Boulevard South of Suburban Lane
- Perris Boulevard from Northern Dancer Drive to Krameria Avenue
- Perris Boulevard South of Santiago Drive
- Perris Boulevard South of Gentian Avenue
- Perris Boulevard North of Gentian Avenue
- Perris Boulevard from Delphinium Avenue to Cactus Avenue

Said locations, hereinafter referred to as the "District Facility Locations," are shown and depicted on Exhibits "A" through "F" and

WHEREAS, the purpose of this Agreement is to set forth financial and other terms and conditions associated with the additional work at the District Facility Locations by City.

NOW, THEREFORE, in consideration of the above recited premises, together with the mutual covenants herein contained, it is mutually agreed as follows:

AGREEMENT

1. DESCRIPTION OF WORK.

The work included at the District Facilities Locations includes construction of an alternate street section above and adjacent to the District Facilities in order to avoid compaction directly above the District Facilities. This additional work includes installation of controlled low-strength material (CLSM), additional roadway excavation, and additional asphalt concrete. Refer to Exhibits "G" through "J" for an estimated quantity and cost breakdown.

In addition to the construction work, services provided by the City, associated with the additional work include project engineering, contract administration, geotechnical testing, construction surveying, and inspection.

2. FINANCIAL OBLIGATIONS AND RESPONSIBILITIES.

The District shall be solely responsible for costs associated with the additional work at District Facility Locations. The District agrees to pay the construction and construction related costs, which are estimated at \$220,000 as shown on Exhibits "G" through "J", attached hereto. In the event that the final quantities are either higher or lower than estimated, the City will provide a final cost summary to the District and the District shall bear full financial responsibility for all costs associated with the work.

Upon completion of construction and determination of final costs, the City shall notify the District of the final cost summary. Determination of final costs will be based on actual costs for all work. The District will make a payment to the City, within 30 days following the City's notification to the District of the actual total costs.

Any contract changes to the District's work shall be in writing, executed by the City with the approval of the District. Additional costs owed the City's contractor as a result of the approved change order shall be invoiced by the City to the District at the time such payment is requested by the contractor. The District will pay the City within thirty (30) calendar days of receipt of the City's invoice.

Neither the City nor the District will assess permit fees or plan check fees to each other.

3. CONSTRUCTION AWARD.

The District acknowledges that the City has awarded the construction contract for the City Project to the lowest successful bidder, Hillcrest Contracting, Inc. Hillcrest Contracting, Inc. therefore, will complete the additional work at the District Facilities Locations.

4. CONSTRUCTION TIMELINE.

Completion of the additional work at the District Facilities Locations shall be performed concurrently with the City Project.

5. CONSTRUCTION PLANS AND SPECIFICATIONS.

The District acknowledges that the Plans and Specifications for the City Project, as it relates to the District Facilities, were reviewed and approved by the District.

6. CEQA

The City shall be individually responsible for compliance with the State of California, Environmental Acts as these acts pertain to the entire City Project. The District shall cooperate with the City to implement the applicable Environmental Mitigations for the District Facilities.

7. CONSTRUCTION AND INSPECTION RESPONSIBILITIES

All District Facilities furnished, constructed, and installed by the City's contractor shall be installed in compliance with the City Project Plans and Specifications. All materials furnished by the City's contractor must conform to the District's approved material list. Any and all deviations from Exhibits "A" through "F" must be approved by the District, in writing, prior to being made. Change Orders related to this work will not be paid for without the District's prior written approval.

The District shall be responsible to inspect the furnishing and installation of all District Facilities and the performance of the involved work by the City's contractor for compliance with the City Project Plans and Specifications. It is specifically understood that the District's inspection personnel shall have the authority to enforce the City Project Plans and Specifications for the involved facilities, which authority shall include the authority to require that any and all unacceptable materials, workmanship and/or installation be replaced, repaired or corrected by the City's contractor in accordance with the City Project Plans and Specifications. All inspection costs incurred by the District will be solely financed by the District. All contract administration and construction administration costs incurred by District will be paid solely by District.

The District will provide reasonably expeditious submittal review and responses, and approve change orders in a timely manner (5 EMWD working days or less) and will not delay the project construction. Both the District and the City agree to cooperate with each other to complete the work in an expeditious manner. The parties agree that coordinating their respective work is critical to avoiding conflicts, delays, and additional costs.

The District's inspector shall maintain good communication/coordination between the City and the City's contractor to keep all parties informed of the construction activities and any conflicts discovered during construction. If utility conflicts are encountered, the District shall work with said utility company to redesign/resolve the conflicts expeditiously (5 working days or less) in order to meet the project schedule.

8. RECIPROCAL INDEMNIFICATION

The District and the City, the Moreno Valley Community Services District (CSD), and the Moreno Valley Housing Authority, each hereby agree to indemnify, defend, save and hold harmless the other party and their respective officers, agents, servants and employees, of and from any liabilities, claims, demands, suits, action and cause of action arising out of or in any manner connected with any act or omission of such indemnifying party, performed in connection with such party's duties and obligations hereunder.

9. CITY/DISTRICT TO PROVIDE PROFESSIONAL SERVICES

For the period during which the City or its contractor control the job site, the City will provide, or cause to be provided, for the entire period of construction, professional services for construction surveying and geotechnical testing services, and City contract administration.

All costs for professional construction surveying and geotechnical testing services and City contract administration for District Facilities work will be solely financed by the District in accord with Section 2.

The City and District shall each provide, or cause to be provided, for the entire period of District Facilities work, professional services for project management, design, and plan conformance. Any District changes requiring design services will be paid by District and any City changes requiring design services will be paid by the City.

10. SUCCESSORS AND ASSIGNS

This Agreement shall inure to the benefit of and be binding on each of the parties and their successors and assigns.

11. EFFECTIVE DATE

This Agreement shall become effective upon acceptance hereof by City and District and by execution by their respective authorized representatives.

12. NOTICES

All notices under this Agreement shall be sent as follows:

EMWD: Eastern Municipal Water District
2270 Trumble Road
P.O. Box 8300
Perris, CA 92572-8300
ATTN: Armando Arroyo, Senior Civil Engineer

CITY: City of Moreno Valley
14177 Frederick Street
PO Box 88005
Moreno Valley, CA 92552-0805
ATTN: Larry Gonzales, Senior Engineer, P.E.

Either party may change its address for notices by notifying the other party. All notices given at the most recent address specified shall be deemed to have been properly given.

13. GENERAL

This Agreement contains the entire agreement between the parties with respect to the matters herein provided for and may only be amended by a subsequent written Agreement executed by all parties. This Agreement may be executed in counterparts, each of which shall be deemed an original, but which together shall constitute a single Agreement.

IN WITNESS WHEREOF, the parties hereto have executed this Agreement as of the date indicated above.

CITY OF MORENO VALLEY

EASTERN MUNICIPAL WATER DISTRICT

By: _____
City Manager

By: _____
Paul D. Jones II, General Manager

Dated: _____

Dated: _____

APPROVED AS TO FORM:

ATTEST:

City Attorney

Rosemarie V. Howell, Board Secretary

- Attachments:
- Exhibit "A" – Perris Boulevard, South of Suburban Lane
 - Exhibit "B" – Perris Boulevard from Northern Dancer Drive to Krameria Avenue
 - Exhibit "C" – Perris Boulevard, South of Santiago Drive
 - Exhibit "D" – Perris Boulevard, South of Gentian Avenue
 - Exhibit "E" – Perris Boulevard, North of Gentian Avenue
 - Exhibit "F" – Perris Boulevard from Delphinium Avenue to Cactus Avenue
 - Exhibit "G" – Cost Estimate Summary
 - Exhibit "H" – Bid Item Prices for Perris Boulevard – EMWD Protection
 - Exhibit "I" – Bid Item Prices for EMWD Protection and R & R at Delphinium Avenue
 - Exhibit "J" – Materials Cost Estimate

W:\CapProj\CapProj\PROJECTS\Larry - 11-41570125 Perris Blvd. from PVSD Lateral B to Cactus Ave\Utility\Water - EMWD\Utility Agreement_EMWD 011413 v2.doc

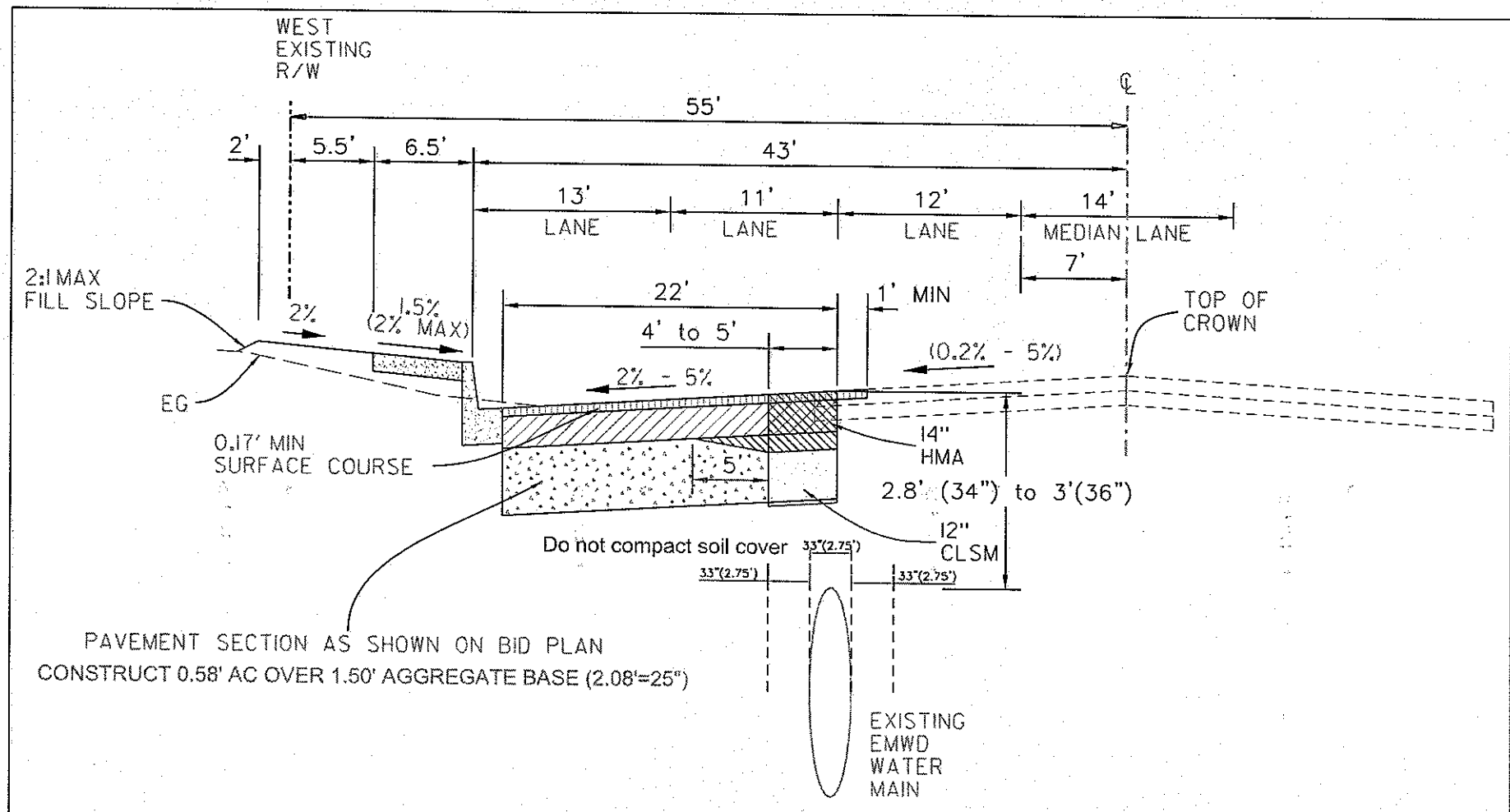

*MODIFIED PAVEMENT SECTION ABOVE EMWD WATER MAIN
TYPICAL SECTION - SOUTH OF SUBURBAN LANE*

HORIZ - 1"=10'
VERT - 1"=2'
STA 276+00 TO STA 279+90

Item No. A.7

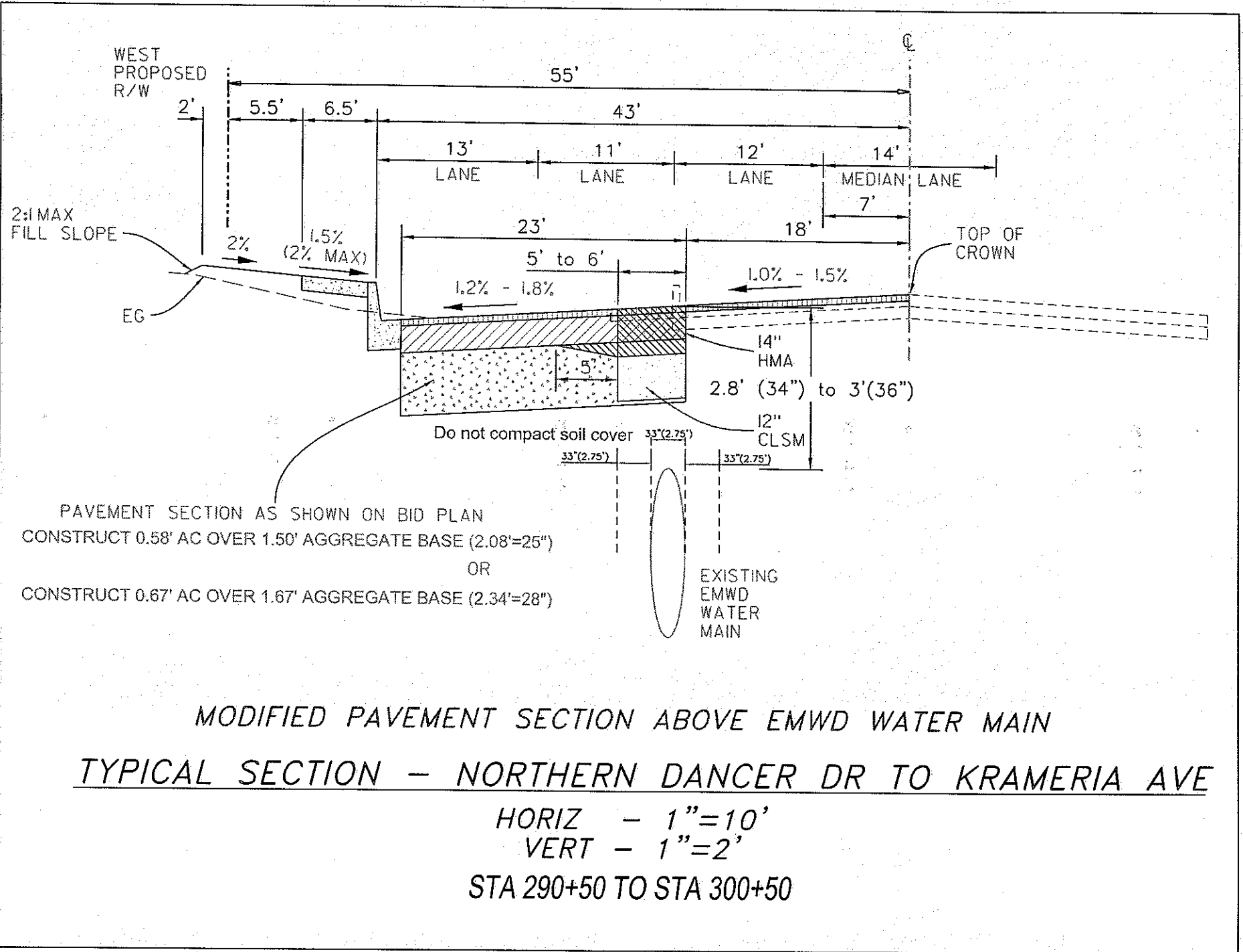

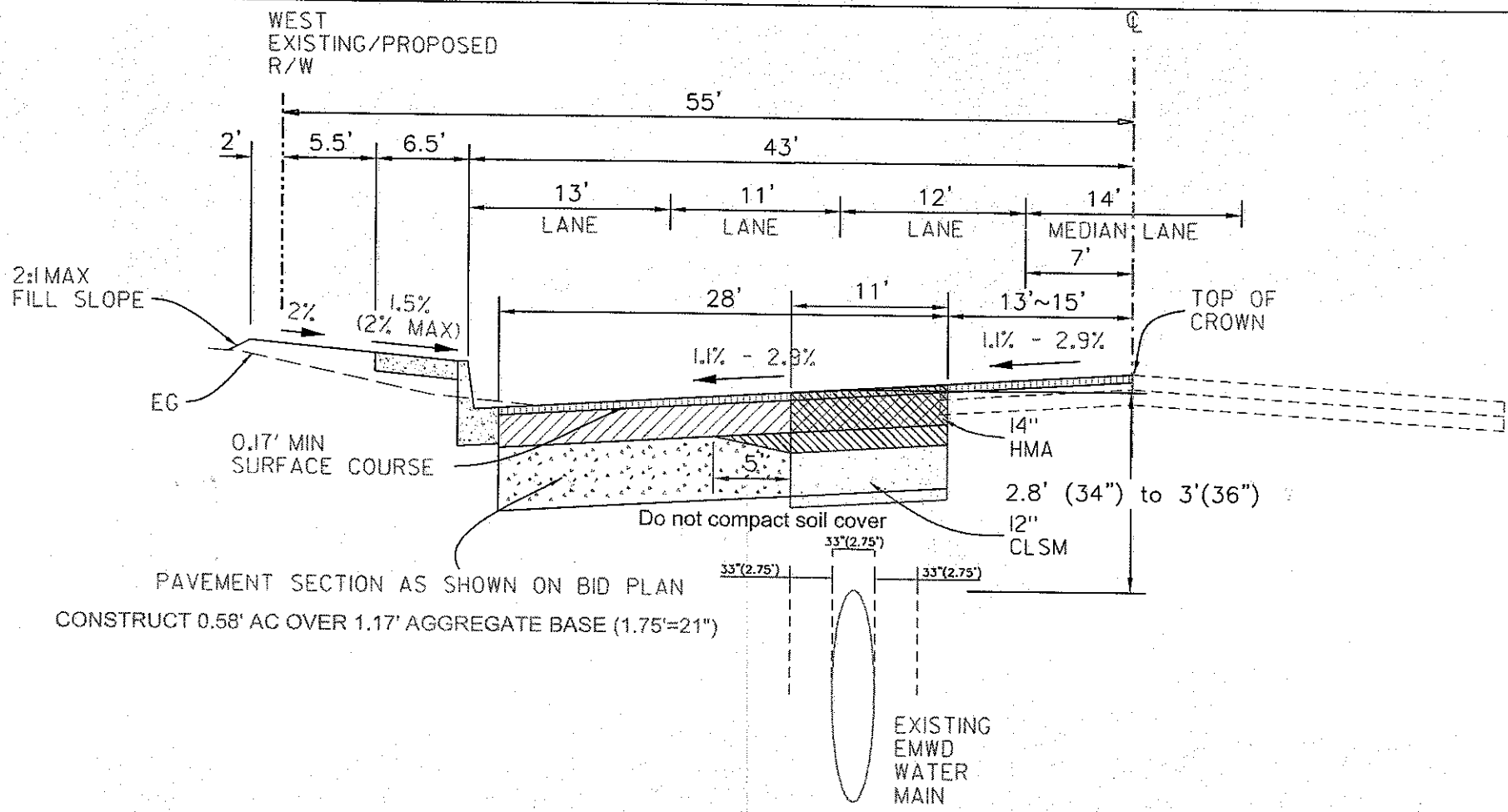

PAVEMENT SECTION AS SHOWN ON BID PLAN
 CONSTRUCT 0.58' AC OVER 1.17' AGGREGATE BASE (1.75'=21")

*MODIFIED PAVEMENT SECTION ABOVE EMWD WATER MAIN
 TYPICAL SECTION - SOUTH OF SANTIAGO DRIVE*

HORIZ - 1"=10'
 VERT - 1"=2'
 STA 336+03 TO STA 340+09

-167-

Item No. A.7

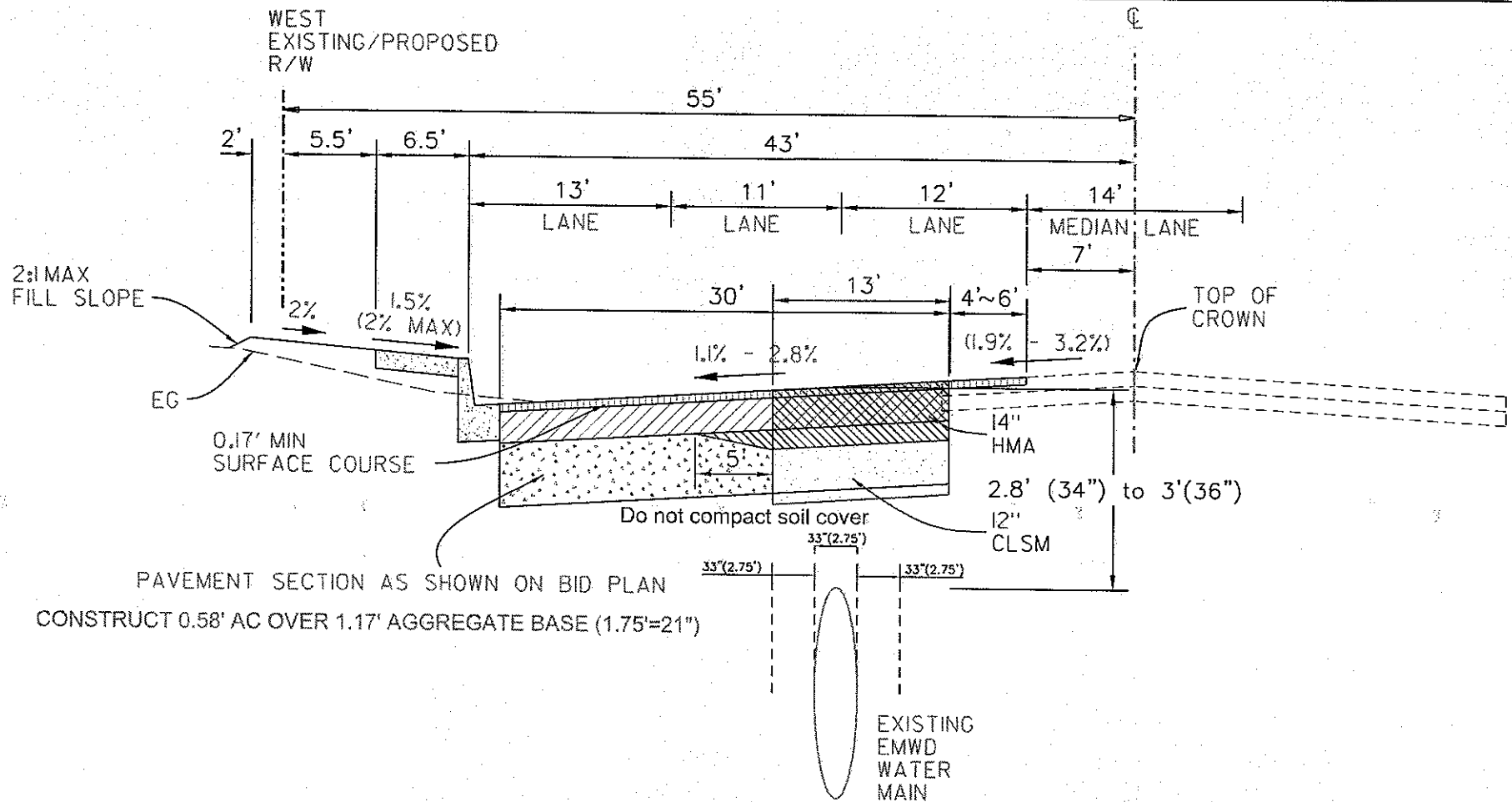

MODIFIED PAVEMENT SECTION ABOVE EMWD WATER MAIN

TYPICAL SECTION - GENTIAN AVE SOUTH

HORIZ - 1"=10'

VERT - 1"=2'

STA 340+41 TO STA 346+43

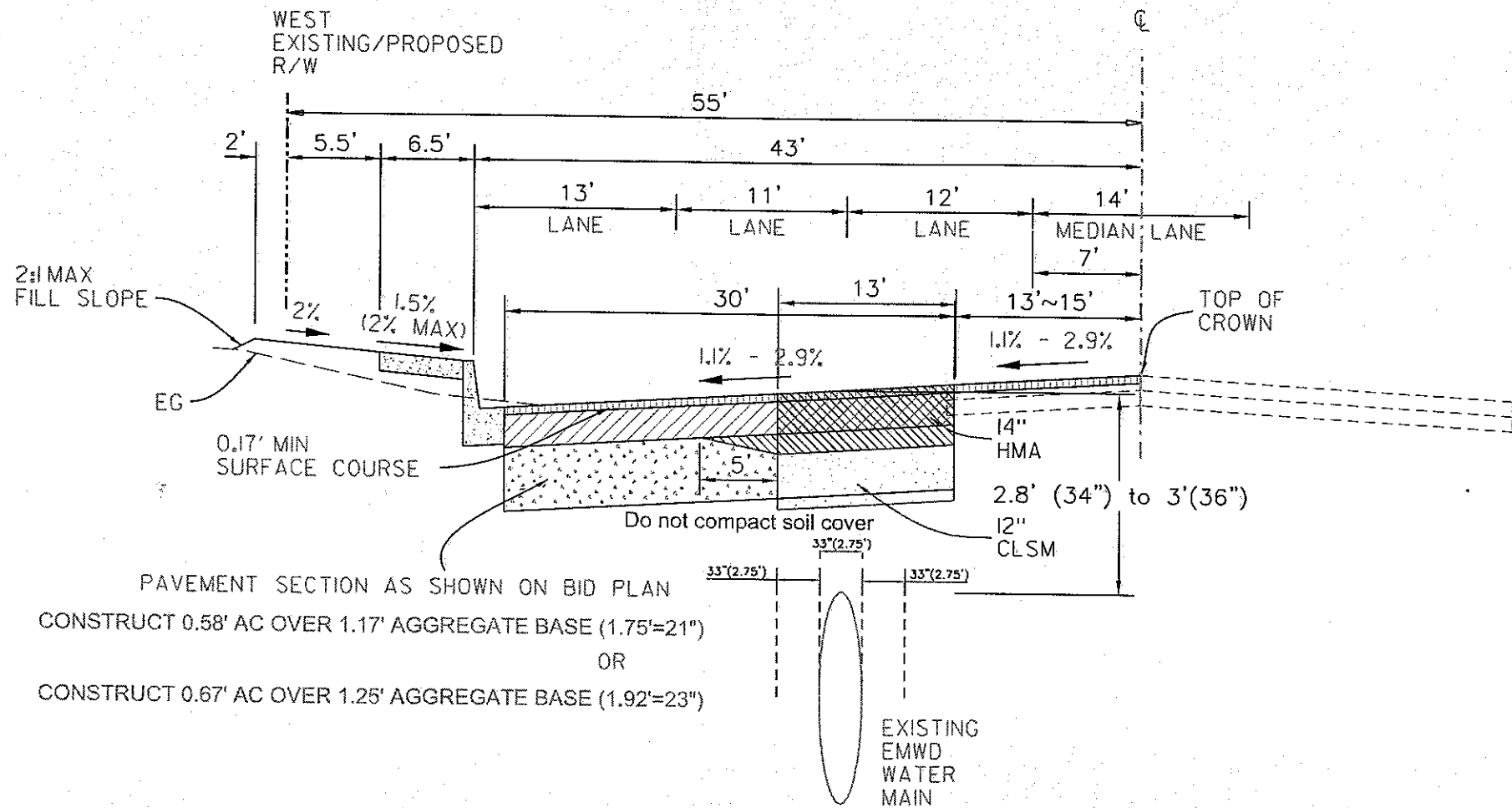

MODIFIED PAVEMENT SECTION ABOVE EMWD WATER MAIN

TYPICAL SECTION - GENTIAN AVE NORTH

HORIZ - 1"=10'

VERT - 1"=2'

STA 356+54 TO STA 359+93

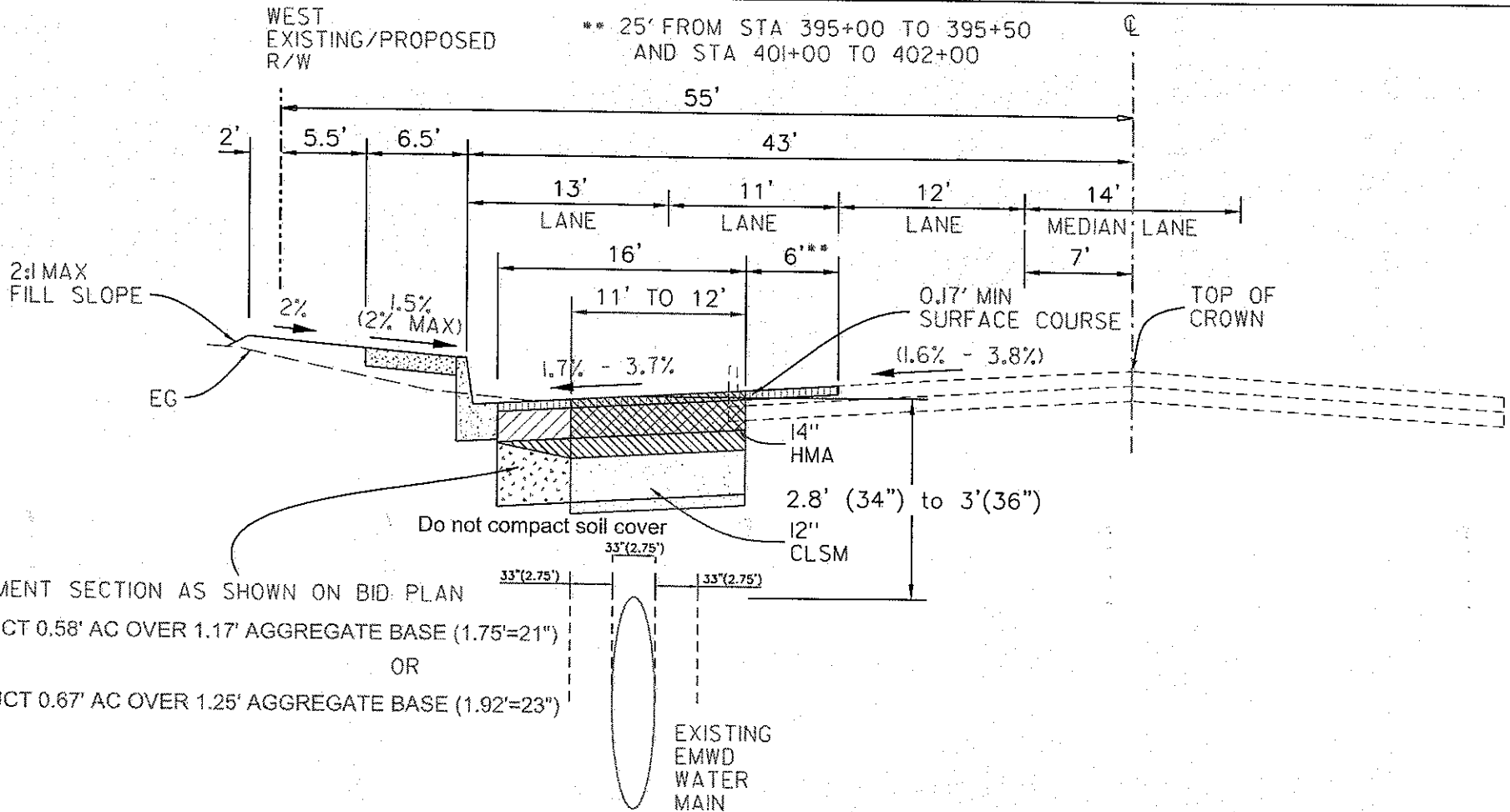

PAVEMENT SECTION AS SHOWN ON BID. PLAN
 CONSTRUCT 0.58' AC OVER 1.17' AGGREGATE BASE (1.75'=21")
 OR
 CONSTRUCT 0.67' AC OVER 1.25' AGGREGATE BASE (1.92'=23")

MODIFIED PAVEMENT SECTION ABOVE EMWD WATER MAIN
TYPICAL SECTION - DELPHINIUM AVE TO CACTUS AVE

HORIZ - 1"=10'
 VERT - 1"=2'
 STA 393+37 TO STA 404+33

Cost Estimate Summary

Perris Boulevard - EMWD Protection*	\$149,972.00
EMWD Protection and R & R at Delphinium**	\$22,055.40
Project Materials***	<u>\$48,082</u>
Total:	\$220,000.00 (rounded)

*See Exhibit "H" for detailed cost breakdown

**See Exhibit "I" for detailed cost breakdown

***See Exhibit "J" for detailed cost breakdown

**Bid Item Prices for : PERRIS BLVD. - EMWD PROTECTION -
Copy**

Hillcrest Contracting

JASON JONES

1/28/2013

<i>Item</i>	<i>Description</i>	<i>Quantity U/M</i>	<i>Unit Price</i>	<i>Total Price</i>
2 1	EXCAVATE TRENCH	1,070.00 CY	\$30.000	\$32,100.00
2 2	FILL TRENCH WITH SLURRY	1,070.00 CY	\$86.049	\$92,072.00
2 3	BASE MATERIAL EXTRA COSTS	1.00 LS	\$15,800.000	\$15,800.00
2 4	AC PAVING EXTRA COSTS	1.00 LS	\$10,000.000	\$10,000.00
Phase 2	TRENCH & FILL WITH SLURR Subtotal			\$149,972.00

BID TOTALS

Details Report For : PERRIS BLVD. - EMWD PROTECTION - Copy

Hillcrest Contracting · JASON JONES 1/28/2013

Ph.	Item	Description	Quantity	U/M	Unit Cost	Total Cost	Margin%	Unit Price	Total Price
2	1	EXCAVATE TRENCH	1,070.00	CY	\$26.99	\$28,879.30	11.15	30.00	\$32,100.00

Activity	EXCAVATION WITH BACKHOE	Crew	EXCAVATION WITH BACK	Activity Qty	1,070.00	CY
	Rate:		Days:	TotalCost:		28,530.85
Day:	214.00 CY	Labor	5.00	UnitCost:		26.664
Hour:	26.80 CY	Equipment	5.00			
		Actual:	5.00			
Labor		Quantity	Hours	Days	Unit Cost	
GENFO GENERAL FOREMAN G	1.00	9.00	HR	5.00	\$78.56	\$3,535.34
LAB 1 LABORER GROUP 1	2.00	8.00	HR	5.00	\$59.15	\$4,731.68
The total contains overtime cost of :				\$163.83	Total	\$8,430.85
Equipment		Quantity	Hours	Days	Unit Cost	
TRPU PICKUP TRUCK	1.00	8.00	HR	5.00	\$20.00	\$800.00
BKHOE BACKHOE	1.00	8.00	HR	5.00	\$135.00	\$5,400.00
					Total	\$6,200.00
Trucks				Quantity	Unit Cost	
SEMI SEMI DUMP TRUCK				160.00	\$85.00	\$13,600.00
					Total	\$13,600.00
Other				Quantity	Unit Cost	
EQM 1 EQUIPMENT MOVE RA				1.00	\$300.00	\$300.00
					Total	\$300.00

Act Note:

Item Note:

Details Report For : PERRIS BLVD. - EMWD PROTECTION - Copy

Hillcrest Contracting

JASON JONES

1/28/2013

Ph.	Item	Description	Quantity	U/M	Unit Cost	Total Cost	Margin%	Unit Pricet	Total Price
2	2	FILL TRENCH WITH SLURRY	1,070.00	CY	\$76.31	\$81,652.37	12.76	86.05	\$92,072.00

Activity POUR SLURRY **Crew** 5 MAN CONCRETE CREW **Activity Qty** 1,070.00 CY

Day:	Rate: 194.50 CY	Labor	Days: 5.50	TotalCost:	80,871.14
Hour:	24.30 CY	Equipment	5.50	UnitCost:	75.581
		Actual:	5.50		

Labor	Quantity	Hours	Days	Unit Cost	
4MPCC FOREMAN CONCRETE	1.00	9.00 HR	5.50	\$72.72	\$3,599.59
MAS CEMENT MASON	4.00	8.00 HR	5.50	\$67.00	\$11,792.53
LABPC LABOR CONCRETE W	1.00	8.00 HR	5.50	\$62.60	\$2,754.49
The total contains overtime cost of :				\$164.53	
				Total	\$18,311.14

Equipment	Quantity	Hours	Days	Unit Cost	
TRPU PICKUP TRUCK	1.00	8.00 HR	5.50	\$20.00	\$880.00
TRCRE CREW TRUCK	1.00	8.00 HR	5.50	\$40.00	\$1,760.00
				Total	\$2,640.00

Material	Quantity	Unit Cost	
CONLO CONCRETE LOAD ENVI	107.00	\$50.00	\$5,350.00
MISC L CONCRETE LUMBER, E	1,070.00	\$2.00	\$2,140.00
SLURR SLURRY	1,070.00	\$49.00	\$52,430.00
			Total \$59,920.00

Act Note:

Item Note:

Details Report For : PERRIS BLVD. - EMWD PROTECTION - Copy

Hillcrest Contracting

JASON JONES

1/28/2013

Ph.	Item	Description	Quantity	U/M	Unit Cost	Total Cost	Margin%	Unit Price	Total Price
2	3	BASE MATERIAL EXTRA COSTS	1.00	LS	\$13,141.59	\$13,141.59	20.22	15,800.00	\$15,800.00

Activity	PLACE BASE WITH SKIPLOADER	Crew	PLACE BASE SKIPLOADER	Activity Qty	400.00 TN
	<i>Rate:</i>			<i>Days:</i>	
Day:	200.00 TN		Labor	2.00	TotalCost: 8,804.66
Hour:	25.00 TN		Equipment	2.00	UnitCost: 22.012
			Actual:	2.00	
Labor					
		Quantity	Hours	Days	Unit Cost
GENFO	GENERAL FOREMAN G	1.00	8.00 HR	2.00	\$78.56 \$1,257.01
LAB 1	LABORER GROUP 1	2.00	8.00 HR	2.00	\$59.15 \$1,892.67
OROL	ROLLER OPERATOR G-	1.00	8.00 HR	2.00	\$83.44 \$1,334.98
					Total \$4,484.66
Equipment					
		Quantity	Hours	Days	Unit Cost
SKIP	SKIPLOADER	1.00	8.00 HR	2.00	\$100.00 \$1,600.00
TRW20	WATER TRUCK 2000 G	1.00	8.00 HR	2.00	\$95.00 \$1,520.00
TRPU	PICKUP TRUCK	1.00	8.00 HR	2.00	\$20.00 \$320.00
RLPUP	ROLLER PUP	1.00	8.00 HR	2.00	\$30.00 \$480.00
					Total \$3,920.00
Material					
				Quantity	Unit Cost
ABT&T	AGG BASE HAUL INCR			400.00	\$1.00 \$400.00
					Total \$400.00

Act Note:

Details Report For : PERRIS BLVD. - EMWD PROTECTION - Copy

Hillcrest Contracting

JASON JONES

1/28/2013

Ph.	Item	Description	Quantity	UM	Unit Cost	Total Cost	Margin%	Unit Price	Total Price
2	3	BASE MATERIAL EXTRA COSTS	1.00	LS	\$13,141.59	\$13,141.59	20.22	15,800.00	\$15,800.00

Activity	GRADE BASE WITH SKIPLOADE	Crew	GRADE BASE WITH SKIPL	Activity Qty	5,000.00	SF
	<i>Rate:</i>					
Day:	5,000.00	SF	Labor	1.00	TotalCost:	4,202.33
Hour:	625.00	SF	Equipment	1.00	UnitCost:	0.840
			Actual:	1.00		

Labor		Quantity	Hours	Days	Unit Cost	
GENFO	GENERAL FOREMAN G	1.00	8.00	HR	1.00	\$78.56 \$628.50
LAB 1	LABORER GROUP 1	2.00	8.00	HR	1.00	\$59.15 \$946.34
OROL	ROLLER OPERATOR G-	1.00	8.00	HR	1.00	\$83.44 \$667.49
						Total \$2,242.33
Equipment		Quantity	Hours	Days	Unit Cost	
SKIP	SKIPLOADER	1.00	8.00	HR	1.00	\$100.00 \$800.00
TRW20	WATER TRUCK 2000 G	1.00	8.00	HR	1.00	\$95.00 \$760.00
TRPU	PICKUP TRUCK	1.00	8.00	HR	1.00	\$20.00 \$160.00
RLPUP	ROLLER PUP	1.00	8.00	HR	1.00	\$30.00 \$240.00
						Total \$1,960.00

Act Note:

Item Note:

Details Report For : PERRIS BLVD. - EMWD PROTECTION - Copy

Hillcrest Contracting

JASON JONES

1/28/2013

Ph.	Item	Description	Quantity	U/M	Unit Cost	Total Cost	Margin%	Unit Pricet	Total Price
2	4	AC PAVING EXTRA COSTS	1.00	LS	\$8,224.64	\$8,224.64	21.58	10,000.00	\$10,000.00

Activity	PAVE OVER WATER LINE - L & E		Crew	PAVING CREW TWO (2) R		Activity Qty	1,238.00 TN	
	Rate:			Days:		TotalCost:	15,357.72	
Day:	825.30 TN		Labor	1.50		UnitCost:	12.405	
Hour:	103.20 TN		Equipment	1.50				
			Actual:	1.50				
Labor		Quantity	Hours		Days	Unit Cost		
OPM	PAVING MACHINE OPE	1.00	8.00	HR	1.50	\$89.19	\$1,070.24	
OS	SCREEDMAN OPERAT	2.00	8.00	HR	1.50	\$84.47	\$2,027.35	
OROL	ROLLER OPERATOR G-	2.00	8.00	HR	1.50	\$83.44	\$2,002.46	
LAR	ASPHALT RAKER LABO	2.00	8.00	HR	1.50	\$63.87	\$1,532.93	
LAS	ASPHALT SHOVELER L	2.00	8.00	HR	1.50	\$60.66	\$1,455.72	
FMASP	FOREMAN ASPHALT	1.00	8.00	HR	1.50	\$79.09	\$949.02	
						Total	\$9,037.72	
Equipment		Quantity	Hours		Days	Unit Cost		
TRPU	PICKUP TRUCK	1.00	8.00	HR	1.50	\$20.00	\$240.00	
TRCRE	CREW TRUCK	1.00	8.00	HR	1.50	\$40.00	\$480.00	
PAVMA	PAVING MACHINE	1.00	8.00	HR	1.50	\$150.00	\$1,800.00	
RLGBV	ROLLER GRADE VIBRA	2.00	8.00	HR	1.50	\$50.00	\$1,200.00	
SWEEP	SWEEPER	1.00	8.00	HR	1.50	\$125.00	\$1,500.00	
						Total	\$5,220.00	
Other						Quantity	Unit Cost	
EQM 1	EQUIPMENT MOVE RA					2.00	\$300.00	\$600.00
EQM 2	EQUIPMENT MOVE RA					1.00	\$500.00	\$500.00
						Total		\$1,100.00

Act Note:

Activity	ORIGINAL L&E		Crew	MISCELLANEOUS		Activity Qty	1.00 LS	
	Rate:			Days:		TotalCost:	-7,217.54	
Day:	1.00 LS		Labor	1.00		UnitCost:	-7,217.540	
Hour:	0.10 LS		Equipment	1.00				
			Actual:	1.00				
Other						Quantity	Unit Cost	
PLUG	PLUG DETAILS					1,238.00	(\$5.83)	(\$7,217.54)
						Total		(\$7,217.54)

Act Note:

Item Note:

Details Report For : PERRIS BLVD. - EMWD PROTECTION - Copy

Hillcrest Contracting	JASON JONES		1/28/2013
	<i>Cost</i>	<i>%MU</i>	<i>Price</i>
<i>Labor</i>	\$42,507	25.00	\$53,133
<i>Equip</i>	\$19,940	15.00	\$22,931
<i>Equip.Rent</i>	\$0	15.00	\$0
<i>Material</i>	\$60,320	8.00	\$65,146
<i>Transportation</i>	\$13,600	15.00	\$15,640
<i>Sub/Service</i>	\$0	5.00	\$0
<i>Other</i>	(\$5,818)	20.00	(\$6,981)
<i>Bond</i>	\$1,349	20.00	\$1,618
Total Bid	\$131,898	13.70	\$149,972
Total Margin	\$18,074		

**Bid Item Prices for : EMWD PROTECTION & R&R @ DELPHINIUM -
Copy**

Hillcrest Contracting

JASON JONES

1/28/2013

<i>Item</i>	<i>Description</i>	<i>Quantity U/M</i>	<i>Unit Price</i>	<i>Total Price</i>
2 1	REMOVE AC/DIRT FILL W/SLURRY & PLATE	360.00 SF	\$14.290	\$5,144.40
2 2	AC PAVE E/O X-GTR INCL AC/DIRT REMOVAL	1,000.00 SF	\$8.460	\$8,460.00
2 3	AC PAVE W.O X-GTR INCL AC/DIRT REMOVAL	900.00 SF	\$9.390	\$8,451.00
Phase 2	REVISED SLURRY LIMIT & DE Subtotal			\$22,055.40

BID TOTALS

Details Report For : EMWD PROTECTION & R&R @ DELPHINIU

Hillcrest Contracting

JASON JONES

1/28/2013

Ph.	Item	Description	Quantity	U/M	Unit Cost	Total Cost	Margin%	Unit Price	Total Price
2	1	REMOVE AC/DIRT FILL W/SLURRY & PLATE	360.00	SF	\$12.42	\$4,471.20	15.05	14.29	\$5,144.40

Activity DIG OUT AND SLURRY BACK **Crew** 5 MAN CONCRETE CREW **Activity Qty** 360.00 SF

	Rate:			Labor	Days:	TotalCost:	
Day:	720.00	SF	13 CY		0.50		4,422.21
Hour:	90.00	SF		Equipment	0.50	UnitCost:	12.284
				Actual:	0.50		

Labor		Quantity	Hours		Days	Unit Cost	
4MPCC	FOREMAN CONCRETE	1.00	9.00	HR	0.50	\$72.72	\$327.24
MAS	CEMENT MASON	2.00	8.00	HR	0.50	\$67.00	\$536.02
LABPC	LABOR CONCRETE W	1.00	8.00	HR	0.50	\$62.60	\$250.41
LAB 1	LABORER GROUP 1	1.00	8.00	HR	0.50	\$59.15	\$236.58

The total contains overtime cost of : \$14.96

Total \$1,365.21

Equipment		Quantity	Hours		Days	Unit Cost	
TRPU	PICKUP TRUCK	1.00	8.00	HR	0.50	\$20.00	\$80.00
TRCRE	CREW TRUCK	1.00	8.00	HR	0.50	\$40.00	\$160.00
BKHoe	BACKHOE	1.00	8.00	HR	0.50	\$135.00	\$540.00
TR10W	TEN WHEELER	1.00	8.00	HR	0.50	\$85.00	\$340.00
SAW	SAW CUT	1.00	8.00	HR	0.50	\$125.00	\$500.00

Total \$1,620.00

Material		Quantity	Unit Cost	
CONLO	CONCRETE LOAD ENVI	2.00	\$50.00	\$100.00
SLURR	SLURRY	13.00	\$49.00	\$637.00
TRENC	TRENCH PLATES	1.00	\$700.00	\$700.00

Total \$1,437.00

Act Note:

Item Note:

Details Report For : EMWD PROTECTION & R&R @ DELPHINIU

Hillcrest Contracting

JASON JONES

1/28/2013

Ph.	Item	Description	Quantity	U/M	Unit Cost	Total Cost	Margin%	Unit Pricet	Total Price
2	2	AC PAVE E/O X-GTR INCL AC/DIRT REMOVAL - 14"	1,000.00	SF	\$7.36	\$7,359.20	14.95	8.46	\$8,460.00

Activity R & R AC/AB **Crew** PAVING CREW SKIPLOAD **Activity Qty** 1,000.00 SF

	<i>Rate:</i>			<i>Days:</i>		TotalCost:	7,220.53
Day:	1,020.00 SF	84 TN AC	Labor	1.00		UnitCost:	7.221
Hour:	127.50 SF		Equipment	1.00			
			Actual:	1.00			

Labor	Quantity	Hours	Days	Unit Cost	
OROL ROLLER OPERATOR G-	1.00	8.00 HR	1.00	\$83.44	\$667.49
FMASP FOREMAN ASPHALT	1.00	8.00 HR	1.00	\$79.09	\$632.68
LAR ASPHALT RAKER LABO	2.00	8.00 HR	1.00	\$63.87	\$1,021.95
LAS ASPHALT SHOVELER L	1.00	8.00 HR	1.00	\$60.66	\$485.24
LAB 1 LABORER GROUP 1	1.00	8.00 HR	1.00	\$59.15	\$473.17

Total \$3,280.53

Equipment	Quantity	Hours	Days	Unit Cost	
TRPU PICKUP TRUCK	1.00	8.00 HR	1.00	\$20.00	\$160.00
SKIP SKIPLOADER	1.00	8.00 HR	1.00	\$100.00	\$800.00
RLGBV ROLLER GRADE VIBRA	1.00	8.00 HR	1.00	\$50.00	\$400.00
TRCRE CREW TRUCK	1.00	8.00 HR	1.00	\$40.00	\$320.00
RLPUP ROLLER PUP	1.00	4.00 HR	1.00	\$30.00	\$120.00
BKHOE BACKHOE	1.00	4.00 HR	1.00	\$135.00	\$540.00

Total \$2,340.00

Material	Quantity	Unit Cost	
TAC SS 1-H EMULSION	1.00	\$25.00	\$25.00

Total \$25.00

Trucks	Quantity	Unit Cost	
TRKSU SUPER 10 DUMP TRUC	12.00	\$85.00	\$1,020.00

Total \$1,020.00

Other	Quantity	Unit Cost	
EQM 1 EQUIPMENT MOVE RA	1.00	\$300.00	\$300.00
DMP2 DUMP FEES-AC/PCC	3.00	\$85.00	\$255.00

Total \$555.00

Act Note:

Item Note:

Details Report For : EMWD PROTECTION & R&R @ DELPHINIU

Hillcrest Contracting

JASON JONES

1/28/2013

	<i>Cost</i>	<i>%MU</i>	<i>Price</i>
<i>Labor</i>	\$7,926	15.00	\$9,115
<i>Equip</i>	\$6,300	15.00	\$7,245
<i>Equip.Rent</i>	\$0	15.00	\$0
<i>Material</i>	\$1,487	15.00	\$1,710
<i>Transportation</i>	\$2,040	15.00	\$2,346
<i>Sub/Service</i>	\$0	15.00	\$0
<i>Other</i>	\$1,110	15.00	\$1,277
<i>Bond</i>	\$316	15.00	\$363
<i>Total Bid</i>	\$19,178	15.01	\$22,055
<i>Total Margin</i>	\$2,878		

1 Bid Cost: Perris Boulevard Seg. 2 Estimates - South of Suburban					
Item	Description of Construction Items	Quantity	Unit	Bid Unit Cost	Item Cost
1	Roadway Excavation	753	CY	\$20.20	\$15,208
2	Asphalt Concrete	287	TN	\$70.00	\$20,097
3	Aggregate Base	367	CY	\$24.00	\$8,800
TOTAL CONSTRUCTION COST					\$44,105
1 Revised Cost: Perris Boulevard Seg. 2 Estimates - South of Suburban					
Item	Description of Construction Items	Quantity	Unit	Unit Cost	Item Cost
1	Roadway Excavation	702	CY	\$20.20	\$14,183
2	Asphalt Concrete	353	TN	\$70.00	\$24,717
3	Aggregate Base	283	CY	\$24.00	\$6,800
4	12" CLSM	56	CY	\$120.00	\$6,667
TOTAL CONSTRUCTION COST					\$52,367
Total Cost Difference					\$8,262
AC Cost Difference					\$4,620
AB Cost Difference					-\$2,000
2 Bid Cost: Perris Boulevard Improvement - Seg. 1 - Northern Dancer to Krameria					
Item	Description of Construction Items	Quantity	Unit	Unit Cost	Item Cost
1	Roadway Excavation	3,066	CY	\$17.40	\$53,346
2	Asphalt Concrete	1,221	TN	\$70.00	\$85,478
3	Aggregate Base	1,519	CY	\$23.60	\$35,842
TOTAL CONSTRUCTION COST					\$174,666
2 Revised Cost: Perris Boulevard Improvement - Seg. 1 - Northern Dancer to Krameria					
Item	Description of Construction Items	Quantity	Unit	Unit Cost	Item Cost
1	Roadway Excavation	2,819	CY	\$17.40	\$49,059
2	Asphalt Concrete	1,460	TN	\$70.00	\$102,219
3	Aggregate Base	1,163	CY	\$23.60	\$27,438
4	12" CLSM	222	CY	\$120.00	\$26,667
TOTAL CONSTRUCTION COST					\$205,383
Total Cost Difference					\$30,717
AC Cost Difference					\$16,741
AB Cost Difference					-\$8,404
3 Bid Cost: Perris Boulevard Improvement - Seg. 1 - South of Santiago					
Item	Description of Construction Items	Quantity	Unit	Unit Cost	Item Cost
1	Roadway Excavation	913	CY	\$17.40	\$15,879
2	Asphalt Concrete	390	TN	\$70.00	\$27,283
3	Aggregate Base	388	CY	\$23.60	\$9,163
TOTAL CONSTRUCTION COST					\$52,325
3 Revised Cost: Perris Boulevard Improvement - Seg. 1 - South of Santiago					
Item	Description of Construction Items	Quantity	Unit	Unit Cost	Item Cost
1	Roadway Excavation	837	CY	\$17.40	\$14,556
2	Asphalt Concrete	545	TN	\$70.00	\$38,125
3	Aggregate Base	236	CY	\$23.60	\$5,563
4	12" CLSM	130	CY	\$120.00	\$15,644
TOTAL CONSTRUCTION COST					\$73,888
Total Cost Difference					\$21,563
AC Cost Difference					\$10,842
AB Cost Difference					\$3,600

PROJECT'S DETAILED COST ESTIMATE

4 Bid Cost: Perris Boulevard Improvement - Seg. 1 - Gentian South						
Item	Description of Construction Items	Quantity	Unit	Unit Cost	Item Cost	
1	Roadway Excavation	1,818	CY	\$17.40	\$31,634	
2	Asphalt Concrete	776	TN	\$70.00	\$54,353	
3	Aggregate Base	774	CY	\$23.60	\$18,255	
TOTAL CONSTRUCTION COST					\$104,242	
4 Revised Cost: Perris Boulevard Improvement - Seg. 1 - Gentian South						
Item	Description of Construction Items	Quantity	Unit	Unit Cost	Item Cost	
1	Roadway Excavation	1,702	CY	\$17.40	\$29,621	
2	Asphalt Concrete	1,012	TN	\$70.00	\$70,847	
3	Aggregate Base	541	CY	\$23.60	\$12,778	
4	12" CLSM	198	CY	\$120.00	\$23,800	
TOTAL CONSTRUCTION COST					\$137,046	
					Total Cost Difference	\$32,804
					AC Cost Difference	\$16,493
					AB Cost Difference	-\$5,476
5 Bid Cost: Perris Boulevard Improvement - Seg. 1 - Gentian North						
Item	Description of Construction Items	Quantity	Unit	Unit Cost	Item Cost	
1	Roadway Excavation	1,045	CY	\$17.40	\$18,175	
2	Asphalt Concrete	452	TN	\$70.00	\$31,620	
3	Aggregate Base	445	CY	\$23.60	\$10,497	
TOTAL CONSTRUCTION COST					\$60,291	
5 Revised Cost: Perris Boulevard Improvement - Seg. 1 - Gentian North						
Item	Description of Construction Items	Quantity	Unit	Unit Cost	Item Cost	
1	Roadway Excavation	976	CY	\$17.40	\$16,982	
2	Asphalt Concrete	583	TN	\$70.00	\$40,821	
3	Aggregate Base	311	CY	\$23.60	\$7,348	
4	12" CLSM	113	CY	\$120.00	\$13,560	
TOTAL CONSTRUCTION COST					\$78,711	
					Total Cost Difference	\$18,420
					AC Cost Difference	\$9,201
					AB Cost Difference	-\$3,149
6 Bid Cost: Perris Boulevard Seg. 2 Estimates - Cactus to Delphinium						
Item	Description of Construction Items	Quantity	Unit	Bid Unit Cost	Item Cost	
1	Roadway Excavation	1,854	CY	\$20.20	\$37,449	
2	Asphalt Concrete	813	TN	\$70.00	\$56,909	
3	Aggregate Base	789	CY	\$24.00	\$18,945	
TOTAL CONSTRUCTION COST					\$113,303	
6 Revised Cost: Perris Boulevard Seg. 2 Estimates - Cactus to Delphinium						
Item	Description of Construction Items	Quantity	Unit	Unit Cost	Item Cost	
1	Roadway Excavation	1,619	CY	\$20.20	\$32,709	
2	Asphalt Concrete	1,137	TN	\$70.00	\$79,590	
3	Aggregate Base	302	CY	\$24.00	\$7,248	
4	12" CLSM	375	CY	\$120.00	\$44,960	
TOTAL CONSTRUCTION COST					\$164,507	
					Total Cost Difference	\$51,204
					AC Cost Difference	\$22,681
					AB Cost Difference	-\$11,697

PROJECT'S DETAILED COST ESTIMATE

7 New Pavement Section Cost: Perris Boulevard Seg. 2 Estimates - East of Delphinium Intersection					
From Station 392+21.95 to Sta.393+19.67					
Item	Description of Construction Items	Quantity	Unit	Bid Unit Cost	Item Cost
1	Roadway Excavation	132	CY	\$20.20	\$2,670
2	Asphalt Concrete	61	TN	\$70.00	\$4,298
3	Aggregate Base	57	CY	\$24.00	\$1,358
TOTAL CONSTRUCTION COST					\$8,326
7 New Revised Section Cost: Perris Boulevard Seg. 2 Estimates - East of Delphinium Intersection					
From Station 392+21.95 to Sta.393+19.67					
Item	Description of Construction Items	Quantity	Unit	Unit Cost	Item Cost
1	Roadway Excavation	98	CY	\$20.20	\$1,981
2	Asphalt Concrete	107	TN	\$70.00	\$7,485
3	Aggregate Base	0	CY	\$24.00	\$0
4	12" CLSM	28	CY	\$120.00	\$3,409
TOTAL CONSTRUCTION COST					\$12,874
Total Cost Difference					\$4,549
AC Cost Difference					\$3,186
AB Cost Difference					-\$1,358
Grand Total Cost Difference					\$167,518
Grand AC Cost Difference					\$83,765
Grand AB Cost Difference					-\$35,684
Grand AC+AB Difference					\$48,082

This page intentionally left blank.

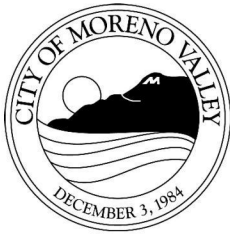

APPROVALS	
BUDGET OFFICER	
CITY ATTORNEY	<i>SMB</i>
CITY MANAGER	<i>MTO</i>

Report to City Council

TO: Mayor and City Council

FROM: Ahmad R. Ansari, P.E., Public Works Director/City Engineer

AGENDA DATE: February 26, 2013

TITLE: APPROVE THE COOPERATIVE AGREEMENT WITH RIVERSIDE COUNTY FLOOD CONTROL AND WATER CONSERVATION DISTRICT FOR THE MORENO MASTER DRAINAGE PLAN LINE F, STAGE 2, AND AUTHORIZE THE APPROPRIATION OF FUNDS, PROJECT NO. 804 0005 70 77

RECOMMENDED ACTION

Recommendations:

1. Approve the Cooperative Agreement with Riverside County Flood Control and Water Conservation District (the District) for the Moreno Master Drainage Plan Line F, Stage 2, subject to final acceptance of any changes by the City Manager and City Attorney, as well as approval of the appropriation of monies subject to the County Board of Supervisors approving the Cooperative Agreement and funding.
2. Authorize the City Manager to execute the Cooperative Agreement upon concurrence by the District.
3. Authorize the City Manager to approve any minor changes that may be requested by the District subject to the approval of the City Attorney.
4. Authorize the City Manager to execute any future amendments subject to the approval of the City Attorney.
5. Authorize the following appropriations: Revenue appropriation of up to \$4,000,000 (3002-99-99-93002); Expense appropriation of up to \$4,000,000 (3002-70-77-80004) in the Public Works General Capital Projects fund.

BACKGROUND

On February 23, 1999, the City Council certified an Environmental Impact Report and a Statement of Overriding Findings which was approved in conjunction with the adoption of the Aquabella Specific Plan (SP 218) (previously Moreno Valley Field Station Specific Plan). The current proposed Cactus Avenue and Nason Street improvements were described and included as part of the approved Aquabella Specific Plan.

On November 22, 2005, the City Council approved an Addendum to the previously certified EIR for the Aquabella Specific Plan.

On December 13, 2005, the City Council, adopted an Ordinance for the Development Agreement and approved the Aquabella Specific Plan Amendment.

On April 26, 2011, the City Council approved an Economic Development Action Plan that re-sequenced Capital Improvement projects to accelerate the street improvements on Cactus Avenue between Lasselle Street and Nason Street, and the extension of Nason Street southerly to connect Cactus Avenue with Iris Avenue.

On June 14, 2011, the City Council approved the Fiscal Year 2011/2012 Capital Improvement Program budget for Cactus Avenue between Lasselle Street and Nason Street, and the extension of Nason Street southerly to connect Cactus Avenue with Iris Avenue.

On March 13, 2012, the City Council approved the award of the construction contract for the Cactus Avenue/Nason Street Improvement Project to Sully-Miller Contracting Company. The Cactus Avenue/Nason Street Improvement Project included flood control facilities of storm drain Line I, J, J-9 and channel Line F, Stage 2 and as part of that City Council Staff Report, it was stated that the project is within the scope of the previously certified Environmental Impact Report and that none of the conditions that call for a Subsequent Environmental Impact Report have occurred. Unfortunately, sufficient funding was not available at that time to fund the ultimate improvements for the flood control channel Line F, Stage 2.

The proposed Moreno Drainage Plan Line F, Stage 2 project will comply with applicable mitigation measures included in the Mitigation Monitoring and Reporting Program that was approved with previously certified Environmental Impact Report.

DISCUSSION

In late October 2012, City staff revisited the funding of Moreno Master Drainage Plan (MDP) Line F, Stage 2 with the District. Following the District's mid-year budget review, sufficient funds in the amount of up to \$4 Million were available to assist the City with the completion of MDP Line F, Stage 2, and the District has provided a Cooperative Agreement to stipulate the terms and conditions. In addition to the District's maximum monetary contribution in the amount of \$4 Million, the Cooperative Agreement indicates that the City will prepare the bidding documents, advertise and administer the project

construction, convey necessary right of way to the District and when construction is complete to the District’s satisfaction, the District will take over the ownership and maintenance of the improvements.

The limits of improvements for the proposed MDP Line F, Stage 2 are approximately 4,500 feet long and starts 800 feet west of Oliver Street to join the existing improved channel in the proximity of Grande Vista Drive and Iris Avenue intersection. The work involved is to fully improve the existing earthen trapezoidal flood control channel with concrete lining. This will complete a ‘missing gap’ of fully improved MDP Line F between Cactus Avenue and the southerly City limit, a distance of 5.5 Miles. It will also complete a majority of the public infrastructure in the City center area to help the City promote and attract new medical related developments, furthering and building upon the expansions underway by surrounding medical facilities which is consistent with the City’s Economic Development Action Plan approved by the City Council in April 2011.

The construction of MDP Line F, Stage 2 will ultimately convey approximately 7,000 cubic feet per second of drainage runoff including concentrated flows from the newly built 10,000 feet of Lines I, J-9 and J storm drains.

ALTERNATIVES

1. Approve and authorize the recommended action as presented in this staff report. *This alternative will provide for the timely construction of Moreno MDP Line F, Stage 2.*
2. Do not approve and authorize the recommended actions as presented in this staff report. *This alternative will delay the construction of Moreno MDP Line F, Stage 2, which may lead to loss of funds currently offered by the District*

FISCAL IMPACT

Pursuant to the terms of the subject Cooperative Agreement between the District and the City, the District will contribute up to \$4,000,000 to construct MDP Line F, Stage 2 flood control channel. There is no impact on the General Fund.

Budget Appropriation

Cat.	Fund	Project No (PN) G/L Account (GL)	Type	Original Budget	Proposed Adjustment	Revised Budget
CIP	Revenue	G/L – 3002-99-99-93002	REV	\$0	\$0	\$4,000,000
CIP	Public Works General Capital Projects Fund (3002)	PN – 804 0005 70 77 G/L – 3002-70-77-80004	EXP	\$0 \$3,958,713	\$4,000,000 \$4,000,000	\$4,000,000 \$7,958,713

TOTAL FUNDS FOR CONSTRUCTION:

Fiscal Year 2012/2013:

(G/L No. 3002-70-77-80004, PN 804 0005 70 77) Appropriation **\$4,000,000**
 Total Budget..... **\$4,000,000**

ESTIMATED PROJECT COSTS:

Design Phase Costs.....	\$50,000
Contractor Construction Costs (includes Contingency).....	\$3,650,000
Construction Design Support Services.....	\$60,000
Construction Survey Services	\$40,000
Construction Geotechnical Services.....	\$60,000
Project Administration *	<u>\$140,000</u>
Total Estimated Project Costs	\$4,000,000

** Public Works and consultant staff will provide Project Administration including inspection services.*

ANTICIPATED PROJECT SCHEDULE:

Start Construction..... May/June 2013
 Anticipated Completion of Construction October/November 2013

CITY COUNCIL GOALS

PUBLIC SAFETY:

Provide a safe and secure environment for people and property in the community, control the number and severity of fire and hazardous material incidents, and provide protection for citizens who live, work and visit the City of Moreno Valley.

PUBLIC FACILITIES AND CAPITAL PROJECTS:

Ensure that needed public facilities, roadway improvements, and other infrastructure improvements are constructed and maintained.

SUMMARY

Pursuant to the proposed Cooperative Agreement with the Riverside County Flood Control and Water Conservation District, the District will contribute up to \$4 Million for the City to complete 4,500 feet of the Moreno Master Drainage Plan Line F, Stage 2 flood control channel.

ATTACHMENTS

- Attachment 1: Location Map
- Attachment 2: Cooperative Agreement

Prepared By:
 Viren A. Shah, P.E.
 Consultant Project Manager

Department Head Approval:
 Barry Foster
 Community and Economic Development
 Director

Concurred By:
 Prem Kumar, P.E.
 Deputy Public Works Director/Assistant City Engineer

Department Head Approval:
 Ahmad R. Ansari, P.E.
 Public Works Director/City Engineer

Council Action	
Approved as requested:	Referred to:
Approved as amended:	For:
Denied:	Continued until:
Other:	Hearing set for:

This page intentionally left blank.

Date: 04 Feb 13 - 2:43 pm
 File: W:\CopProj\CopProj\PROJECTS\Iren - 804 0005 70 77 Line F\Design Phase\Auto CAD\Location_Map\Location_Map.dwg
 User: deepoks

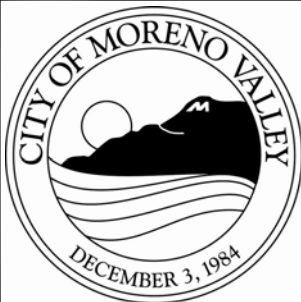
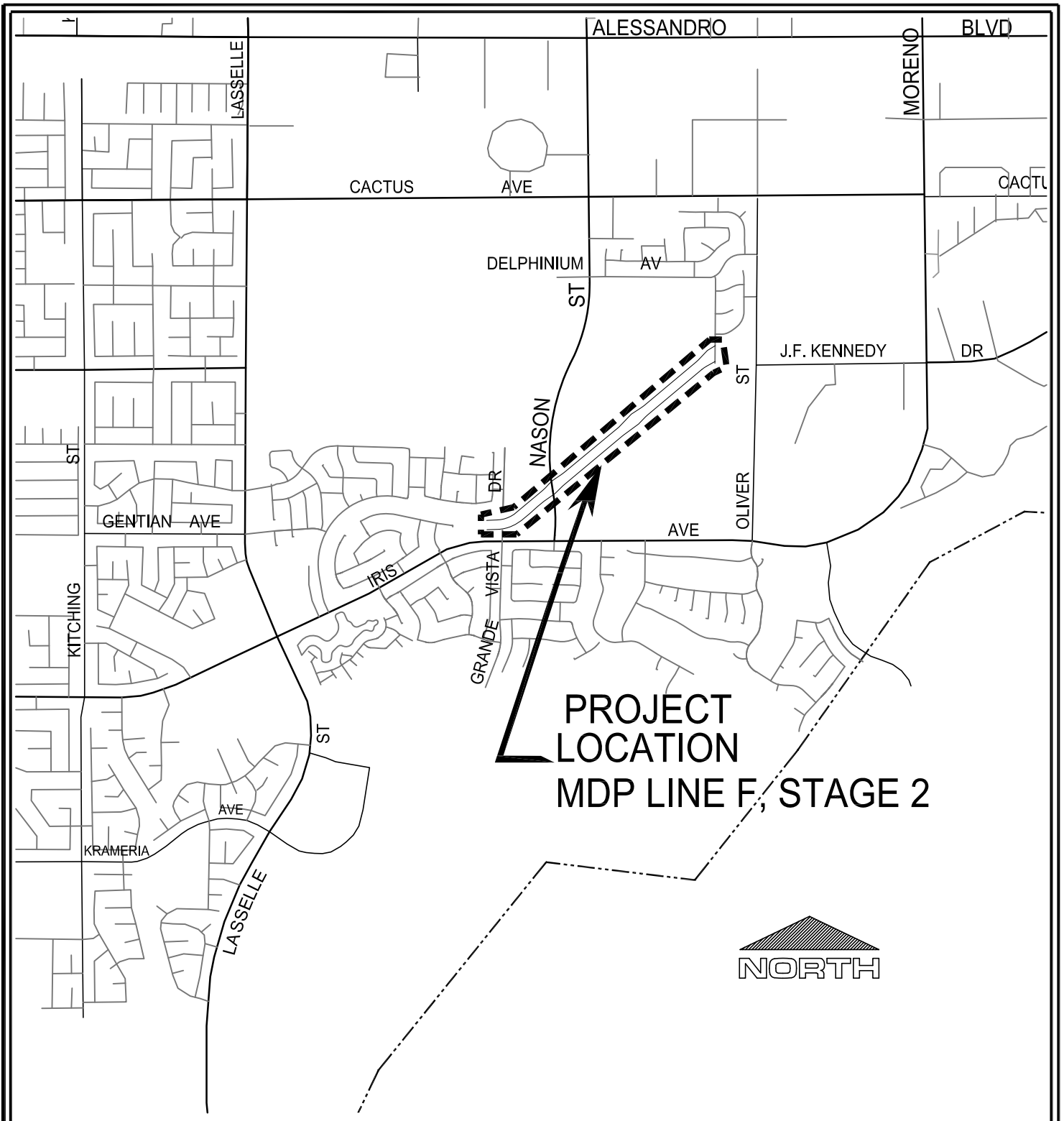

LOCATION MAP

Public Works Department
 Capital Projects Division

Scale: None

ATTACHMENT 1

MORENO MASTER DRAINAGE PLAN
 LINE F, STAGE 2 CHANNEL IMPROVEMENTS
 PROJECT NUMBER 804 0005 70 77

This page intentionally left blank.

COOPERATIVE AGREEMENT
Moreno Master Drainage Plan Line F, Stage 2
(Project No. 4-0-00752)

The RIVERSIDE COUNTY FLOOD CONTROL AND WATER CONSERVATION DISTRICT, hereinafter called "DISTRICT", and the CITY OF MORENO VALLEY, hereinafter called "CITY", hereby agree as follows:

RECITALS

A. DISTRICT, CITY and Moreno Valley Properties, L.P. previously entered into that certain cooperative agreement, hereinafter called "AGREEMENT", dated June 17, 2008, providing for Moreno Valley Properties, L.P. to construct Moreno Master Drainage Plan (MDP) Line F, Stage 2 project in order to provide flood protection and drainage for its planned development of Parcel Map No. 33532; and

B. Pursuant to AGREEMENT, CITY and DISTRICT reviewed and approved the improvement plans for Moreno MDP Line F, Stage 2 project as shown on District Drawing No. 4-912 on November 9, 2007 and October 31, 2008, respectively; and

C. At the Moreno Valley Properties, L.P.'s request due to unfavorable changes in market conditions following the execution of AGREEMENT, DISTRICT, CITY and Moreno Valley Properties, L.P. entered into that certain other agreement, hereinafter called "TERMINATION AGREEMENT", dated May 18, 2010, setting forth the terms and conditions by which DISTRICT, CITY and Moreno Valley Properties, L.P. were each released from their respective obligations set forth in AGREEMENT; and

D. CITY now wishes to expedite the construction of the Moreno MDP Line F, Stage 2 project; and

E. The Moreno MDP Line F, Stage 2 project consists of the construction of (i) approximately 4,500 lineal feet of concrete trapezoidal channel, hereinafter called

1 "CHANNEL", as shown in concept in green on Exhibit "A" attached hereto and made a part
2 hereof, and (ii) thirteen (13) underground storm drain segments, totaling approximately 1,200
3 lineal feet, and their associated outlet structures that are to be located within portions of
4 DISTRICT'S future CHANNEL right of way, hereinafter called "LATERALS", as shown in
5 concept in red on Exhibit "A". At the downstream terminus of CHANNEL, CHANNEL
6 connects to DISTRICT'S existing Line F Channel, as shown on DISTRICT Drawing No. 4-527.
7 Construction of CHANNEL also includes the removal and replacement of approximately 470
8 lineal feet of DISTRICT's existing Line F Channel. Together, CHANNEL and LATERALS are
9 hereinafter called "DISTRICT DRAINAGE FACILITIES"; and
10

11 F. Associated with the construction of DISTRICT DRAINAGE FACILITIES is the
12 construction of a mitigation channel and various lateral storm drain facilities, hereinafter called
13 "APPURTENANCES", which are to be located outside of DISTRICT'S future CHANNEL right
14 of way. Together, DISTRICT DRAINAGE FACILITIES and APPURTENANCES are
15 hereinafter called "PROJECT"; and
16

17 G. CITY desires DISTRICT to contribute funding towards CITY'S construction of
18 PROJECT; and

19 H. CITY also desires DISTRICT to accept ownership and responsibility for the
20 operation and maintenance of DISTRICT DRAINAGE FACILITIES, with the recognition and
21 understanding that the actual acceptance of DISTRICT DRAINAGE FACILITIES for
22 ownership, operation and maintenance by DISTRICT is entirely dependent upon the execution
23 of this Cooperative Agreement and DISTRICT DRAINAGE FACILITIES being constructed in
24 strict accordance with plans and specifications approved by DISTRICT; and
25

26 I. DISTRICT wishes to provide a financial contribution as set forth herein in support
27 of CITY's efforts to construct PROJECT; and
28

J. DISTRICT'S financial contributions shall be as follows:

(i) One hundred percent (100%) of the lowest responsible bid contract price for PROJECT, hereinafter called "INITIAL CONTRIBUTION", plus up to an additional ten percent (10%) to offset any construction contract change orders, hereinafter called "CHANGE ORDERS CONTRIBUTION"; and

(ii) An additional ten percent (10%) of the lowest responsible bid contract price to offset CITY's costs associated with construction contract administration, construction inspection, construction survey and materials testing services, hereinafter called "ADMINISTRATIVE CONTRIBUTION"; and.

K. Altogether, INITIAL CONTRIBUTION, CHANGE ORDERS CONTRIBUTION and ADMINISTRATIVE CONTRIBUTION are hereinafter called "DISTRICT TOTAL CONTRIBUTION". DISTRICT TOTAL CONTRIBUTION shall not exceed a total sum of four million dollars (\$4,000,000) ; and

L. The purpose of this Cooperative Agreement is to memorialize the understandings by and between CITY and DISTRICT with respect to the funding, design, construction, inspection, ownership, operation and maintenance of PROJECT.

NOW THEREFORE, in consideration of the preceding recitals and the mutual covenants hereinafter contained, the parties hereto mutually agree as follows:

SECTION I

CITY shall:

1. Pursuant to the California Environmental Quality Act (CEQA), act as sole Lead Agency and assume responsibility for the preparation, circulation, and adoption of all necessary and appropriate CEQA documents pertaining to the construction, operation and maintenance of PROJECT.

1 2. Prior to advertising PROJECT for construction, submit to DISTRICT for review
2 and approval any changes to the PROJECT plans as previously approved by DISTRICT on
3 October 31, 2008, hereinafter called "PROJECT PLANS".

4 3. Obtain, at its sole cost and expense, all necessary licenses, permits, agreements,
5 approvals, rights of way, rights of entry and temporary construction easements as may be
6 necessary to construct, inspect, operate and maintain PROJECT.

7 4. Submit to DISTRICT for review and approval copies of all permits, approvals or
8 agreements as may be required by any Federal, State or local resource and/or regulatory agency
9 for the construction, operation and maintenance of PROJECT prior to CITY's acceptance or
10 execution thereof. Such documents, hereinafter called "REGULATORY PERMITS", may
11 include, but are not limited to, a Section 404 permit issued by the U.S. Army Corps of
12 Engineers, a Streambed Alteration Agreement issued by the California Department of Fish and
13 Game, a Section 401 Water Quality Certification issued by the California Regional Water
14 Quality Control Board (CRWQCB) and National Pollutant Discharge Elimination System
15 Permit issued by the State Water Resources Control Board or CRWQCB.

16 5. Advertise, award and administer a public works construction contract for the
17 PROJECT.

18 6. Provide DISTRICT with written notice that CITY has awarded a construction
19 contract for PROJECT. The written notice shall include the Contractor's actual bid amount for
20 PROJECT, which shall establish the amount for INITIAL CONTRIBUTION as set forth herein.

21 7. Invoice DISTRICT for one hundred percent (100%) of INITIAL
22 CONTRIBUTION and an additional ten percent (10%) for ADMINISTRATIVE
23 CONTRIBUTION, at the time of providing written notice to DISTRICT of the award of a
24 construction contract, as set forth in Section I.6.
25
26
27
28

1 8. Endeavor to begin PROJECT construction within twelve (12) months of execution
2 of this Agreement.

3 9. Keep an accurate accounting of all construction change orders; payment vouchers
4 and any other construction contract documents as may be necessary to establish the actual cost
5 of construction change orders for PROJECT.

6 10. Construct or cause to be constructed, PROJECT pursuant to a CITY administered
7 public works construction contract, in accordance with DISTRICT approved PROJECT
8 PLANS, and pay all costs associated therewith.

9 11. Inspect PROJECT construction or cause PROJECT's construction to be inspected
10 by its construction manager.

11 12. Furnish, or cause its construction manager to furnish all construction survey and
12 materials testing services necessary to construct PROJECT.

13 13. Grant DISTRICT, by execution of this Agreement, the right to enter upon property
14 owned or controlled by CITY where necessary and convenient for the purpose of gaining access
15 to, and performing inspection service for, the construction of PROJECT.

16 14. Not permit any change to, or modification of, the DISTRICT approved PROJECT
17 PLANS without DISTRICT's prior written consent. Failure to do so shall be deemed a material
18 breach of this Agreement and shall authorize and constitute authority for DISTRICT, at its sole
19 discretion, to provide written notice to CITY that DISTRICT is unable to perform its obligations
20 hereunder, nor to accept responsibility for ownership, operation and maintenance of DISTRICT
21 DRAINAGE FACILITIES due, either in whole or in part, to said breach of this Agreement.

22 15. Require its PROJECT construction contractor(s) to procure and maintain
23 comprehensive liability insurance which shall protect DISTRICT and County of Riverside from
24 claims for damages for personal injury, including accidental or wrongful death, as well as from
25

1 claims for property damage, which may arise from CITY's or its contractor's(s') construction of
2 PROJECT or the performance of its obligations hereunder, whether such construction or
3 performance be by CITY, the aforementioned construction contractor(s), or any subcontractors
4 to said construction contractor(s), or by anyone employed directly or indirectly by said
5 construction contractor(s) or subcontractors. Such insurance shall provide for coverage limits of
6 not less than two million dollars (\$2,000,000) per occurrence and shall name DISTRICT and
7 County of Riverside as additional insureds with respect to this Agreement and the obligations of
8 CITY hereunder. Said insurance coverage shall be provided by an insurance company licensed
9 to transact insurance business in the State of California, having an A.M. Best rating of A: VIII
10 (A:8) or better, and shall be evidenced by a certificate (or certificates) of insurance indicating
11 that the insurance is in full force and effect and that the DISTRICT and the County of Riverside
12 are named as additional insureds. Said certificate(s) of insurance shall contain the covenant of
13 the insurance carrier(s) that sixty (60) days written notice shall be provided to DISTRICT prior
14 to any modification, cancellation, or reduction in coverage of said insurance.
15
16

17 Prior to CITY issuing a Notice to Proceed to its construction contractor(s) to begin
18 construction of PROJECT, an original certificate of insurance evidencing the required insurance
19 coverage shall be provided to DISTRICT.
20

21 16. Require its construction contractor(s) to comply with all Cal/OSHA safety
22 regulations, including regulations concerning confined space and maintain a safe working
23 environment for all CITY and DISTRICT employees on the site.

24 17. Within two (2) weeks of completing PROJECT construction, provide DISTRICT
25 (Attention: Contract Administration Section) with written notice that PROJECT construction is
26 substantially complete and request DISTRICT to conduct a final inspection of PROJECT.
27
28

1 18. Assume ownership and sole responsibility for the operation and maintenance of
 2 PROJECT until such time as DISTRICT accepts ownership and responsibility for the operation
 3 and maintenance of DISTRICT DRAINAGE FACILITIES as set forth herein. CITY shall
 4 continue thereafter to own and have sole responsibility for the operation and maintenance of
 5 APPURTENANCES.

6 19. Upon completion of PROJECT construction but prior to DISTRICT'S acceptance
 7 of DISTRICT DRAINAGE FACILITIES for ownership, operation and maintenance, provide or
 8 cause its construction manager to provide DISTRICT with appropriate engineering
 9 documentation necessary to establish that PROJECT was constructed in accordance with
 10 DISTRICT approved PROJECT PLANS.

12 20. Upon completion of PROJECT construction but prior to DISTRICT's acceptance
 13 of DISTRICT DRAINAGE FACILITIES for ownership, operation and maintenance, provide or
 14 cause its civil engineer of record or construction civil engineer of record, duly registered in the
 15 State of California, to provide DISTRICT with a redlined "RECORD DRAWINGS" copy of
 16 PROJECT plans. After DISTRICT approval of the redlined "RECORD DRAWINGS", CITY'S
 17 engineer shall schedule with DISTRICT a time to transfer the redlined changes onto
 18 DISTRICT'S original mylars at DISTRICT'S office, after which the CITY's engineer shall
 19 review, stamp and sign PROJECT plans "RECORD DRAWINGS".

21 21. Upon completion of PROJECT construction and settlement of any outstanding
 22 claims, provide DISTRICT with a copy of the CITY's recorded Notice of Completion prior to
 23 DISTRICT's acceptance of DISTRICT DRAINAGE FACILITIES for ownership, operation and
 24 maintenance.

26 22. Upon completion of PROJECT construction but prior to DISTRICT's acceptance
 27 of DISTRICT DRAINAGE FACILITIES for ownership, operation and maintenance, convey or
 28

1 cause to be conveyed to DISTRICT (i) fee ownership, in a form approved by DISTRICT, for the
 2 rights of way as shown in concept cross-hatched in blue on Exhibit "B", (ii) drainage and flood
 3 control easements, in a form approved by DISTRICT, for the rights of way as shown in concept
 4 cross-hatched in orange on Exhibit "B", and (iii) ingress and egress easement(s), in a form
 5 approved by DISTRICT, for the rights of way as shown in concept cross-hatched in green and in
 6 red on Exhibit "B".

7 23. At the time of recordation of the conveyance document(s) set forth in Section
 8 I.22.(i), furnish DISTRICT with a policy of title insurance, in an amount of not less than one
 9 hundred percent (100%) of the estimated fee value, as determined by DISTRICT for each parcel
 10 to be conveyed to DISTRICT in fee, guaranteeing DISTRICT's interest in said property as being
 11 free and clear of all liens, encumbrances, assessments, easements, taxes and leases (recorded
 12 and unrecorded), and except those which, in the sole discretion of DISTRICT, are deemed
 13 acceptable.
 14

15 24. At the time of recordation of the conveyance document(s) set forth in Sections
 16 I.22.(ii) and (iii), furnish DISTRICT with policies of title insurance, each in an amount of not
 17 less than fifty percent (50%) of the estimated fee value, as determined by DISTRICT, for each
 18 easement parcel to be conveyed to DISTRICT, guaranteeing DISTRICT's interest in said
 19 property as being free and clear of all liens, encumbrances, assessments, easements, taxes and
 20 leases (recorded and unrecorded), and except those which, in the sole discretion of DISTRICT,
 21 are deemed acceptable.
 22

23 25. Upon DISTRICT's acceptance of DISTRICT DRAINAGE FACILITIES for
 24 operation and maintenance, submit a final invoice to DISTRICT for CHANGE ORDERS
 25 CONTRIBUTION up to a maximum of ten percent (10%) of INITIAL CONTRIBUTION, it
 26 being further provided that the DISTRICT TOTAL CONTRIBUTION shall not exceed a total
 27
 28

1 maximum amount of four million dollars (\$4,000,000). The invoice shall include a final
 2 accounting of all construction change orders and any supporting documents as set forth in
 3 Section I.9.

4 SECTION II

5 DISTRICT shall:

6 1. Act as a Responsible Agency under CEQA, and take all necessary and appropriate
 7 action to comply with CEQA.

8 2. Review and approve any changes made to PROJECT PLANS prior to CITY
 9 advertising of construction contract.

10 3. Pay CITY, within sixty (60) days after receipt of appropriate invoice as set forth in
 11 Section I.7, INITIAL CONTRIBUTION plus ADMINISTRATIVE CONTRIBUTION.

12 4. Review and approve all necessary REGULATORY PERMITS. DISTRICT may
 13 withhold approval of such document(s) when, in the sole judgment of DISTRICT's General
 14 Manager-Chief Engineer, the said document(s) unreasonably constrains, inhibits or impairs
 15 DISTRICT's ability to inspect, operate and maintain DISTRICT DRAINAGE FACILITIES.
 16

17 5. At its sole cost and expense, conduct period inspections of DISTRICT
 18 DRAINAGE FACILITIES construction for quality control purposes and provide any comments
 19 to CITY's designated PROJECT construction manager.
 20

21 6. Upon receipt of CITY'S written notice that PROJECT construction is substantially
 22 complete as set forth in Section I.17, conduct a final inspection of DISTRICT DRAINAGE
 23 FACILITIES.
 24

25 7. Accept ownership and sole responsibility for the operation and maintenance of
 26 DISTRICT DRAINAGE FACILITIES upon (i) DISTRICT inspection of DISTRICT
 27 DRAINAGE FACILITIES in accordance with Section I.17, (ii) DISTRICT acceptance of
 28

1 DISTRICT DRAINAGE FACILITIES as being complete, (iii) DISTRICT receipt of CITY'S
2 recorded Notice of Completion as set forth in Section I.21, (iv) DISTRICT receipt of
3 appropriate engineering documentation as set forth in Section I.19, (v) DISTRICT receipt of
4 stamped and signed RECORD DRAWINGS of PROJECT plans as set forth in Section I.20, (vi)
5 recordation of all conveyance documents described in Section I. 22, and (vii) DISTRICT'S sole
6 determination that DISTRICT DRAINAGE FACILITIES are in a satisfactorily maintained
7 condition.

8
9 8. Pay CITY, within sixty (60) days after receipt of appropriate invoice as set forth in
10 Section I.25, CHANGE ORDERS CONTRIBUTION up to a maximum of ten percent (10%) of
11 INITIAL CONTRIBUTION provided the DISTRICT TOTAL CONTRIBUTION does not
12 exceed a total maximum sum of four million dollars (\$4,000,000).

13 SECTION III

14 It is further mutually agreed:

15
16 1. DISTRICT TOTAL CONTRIBUTION shall not exceed a total maximum sum of
17 four million dollars (\$4,000,000) and shall be used by CITY solely for the purpose of
18 constructing DISTRICT DRAINAGE FACILITIES.

19 2. Except as otherwise provided herein, all construction work involved with
20 PROJECT shall be inspected by CITY and shall not be deemed complete until approved and
21 accepted as complete by CITY.

22 3. DISTRICT personnel may observe and inspect all work being done on PROJECT
23 but shall provide any comments to CITY personnel who shall be responsible for all
24 communications with CITY'S construction contractor(s).

25
26 4. Prior to DISTRICT'S acceptance of ownership and responsibility for the operation
27 and maintenance of DISTRICT DRAINAGE FACILITIES, DISTRICT DRAINAGE
28

1 FACILITIES shall be in a satisfactorily maintained condition as solely determined by
2 DISTRICT. If, in the sole discretion of DISTRICT, DISTRICT DRAINAGE FACILITIES is
3 not in an acceptable condition, corrections will be made at sole expense of CITY.

4 5. CITY shall indemnify, defend, save and hold harmless DISTRICT and County of
5 Riverside (including their respective officers, districts, special districts and departments, their
6 respective directors, officers, Board of Supervisors, elected and appointed officials, employees,
7 agents, representatives, independent contractors, and subcontractors) from any liabilities, claim,
8 damage, proceeding or action, present or future, based upon, arising out of or in any way
9 relating to CITY (including its officers, elected and appointed officials, employees, agents,
10 representatives, independent contractors, and subcontractors) actual or alleged acts or omissions
11 related to this Agreement, performance under this Agreement, or failure to comply with the
12 requirements of this Agreement, including but not limited to: (a) property damage; (b) bodily
13 injury or death; (c) payment of attorney's fees; or (d) any other element of any kind or nature
14 whatsoever.
15

16 6. DISTRICT shall indemnify, defend, save and hold harmless CITY (including its
17 officers, elected and appointed officials, employees, agents, representatives, independent
18 contractors, and subcontractors) from any liabilities, claim, damage, proceeding or action,
19 present or future, based upon, arising out of or in any way relating to DISTRICT (including its
20 officers, Board of Supervisors, elected and appointed officials, employees, agents,
21 representatives, independent contractors, and subcontractors) actual or alleged acts or omissions
22 related to this Agreement, performance under this Agreement, or failure to comply with the
23 requirements of this Agreement, including but not limited to: (a) property damage; (b) bodily
24 injury or death; (c) payment of attorney's fees; or (d) any other element of any kind or nature
25 whatsoever.
26
27
28

1 7. Any waiver by DISTRICT or by CITY of any breach of any one or more
 2 provisions of this Agreement shall not be construed to be a waiver of any subsequent or other
 3 breach of the same or any other provision thereof. Failure on the part of DISTRICT or CITY
 4 to require from the other party exact, full and complete compliance with any of the provisions
 5 of this Agreement shall not be construed as in any manner changing the terms hereof, or
 6 estopping DISTRICT or CITY from enforcement hereof.

7
 8 8. Any and all notices sent or required to be sent to the parties of this Agreement will
 9 be mailed by first class mail, postage prepaid, to the following addresses:

10 RIVERSIDE COUNTY FLOOD CONTROL	CITY OF MORENO VALLEY
11 AND WATER CONSERVATION DISTRICT	Post Office Box 88005
12 1995 Market Street	Moreno Valley, CA 92552-0805
Riverside, CA 92501	Attn: Prem Kumar
Attn: Steve Thomas	

13
 14 9. If any provision in this Agreement is held by a court of competent jurisdiction to
 15 be invalid, void or unenforceable, the remaining provisions shall remain in full force and effect
 16 without being impaired or invalidated in any way.

17 10. This Agreement is to be construed in accordance with the laws of the State of
 18 California.

19 11. This Agreement is made and entered into for the sole protection and benefit of the
 20 parties hereto. No other person or entity shall have any right or action based upon the
 21 provisions of this Agreement.

22 12. This Agreement is the result of negotiations between the parties hereto, and with
 23 the advice and assistance of their respective counsel. No provision contained herein shall be
 24 construed against DISTRICT solely because, as a matter of convenience, DISTRICT prepared
 25 this Agreement in its final form.
 26
 27
 28

13. Pursuant to Government Code Sections 895.4 and 895.6, if any party hereto is held liable upon any judgment for damages caused by a negligent or wrongful act or omission in connection with the performance of their respective duties and obligations set forth in this Agreement and pays in excess of its pro rata share in satisfaction of such judgment, such party shall be entitled to contribution from the other party to this Agreement. The pro rata share of each party for purposes of this Section shall be determined according to the comparative fault of the respective party, as between them.

In the event of any arbitration, action or suit brought by a party hereto against another party hereunder by reason of any breach on the part of the other party of any of the mutual covenants and agreements set forth herein or any other dispute between the parties concerning this Agreement, then, the prevailing party in any such action or dispute, whether by final judgment or arbitration award, shall be entitled to have and recover from the other party all costs and expenses of suit or claim, including but not limited to, attorneys' fees and experts' fees. This Section shall survive any termination of this Agreement.

14. Time is of the essence in prosecuting the work contemplated under this Agreement. In the event CITY does not award a public works construction contract for PROJECT and begin PROJECT construction within twelve (12) months of the execution of this Agreement, DISTRICT may terminate this Agreement for good cause upon providing CITY with a sixty (60) days written notice stating the extent and effective date of termination.

15. This Agreement is intended by the parties hereto as a final expression of their understanding with respect to the subject matter hereof, and is a complete and exclusive statement of the terms and conditions thereof. This Agreement may be changed or modified only upon the written consent of the parties hereto.

//

1
2
3
4
5
6
7
8
9
10
11
12
13
14
15
16
17
18
19
20
21
22
23
24
25
26
27
28

IN WITNESS WHEREOF, the parties hereto have executed this Agreement on

(to be filled in by the Clerk of the Board)

RECOMMENDED FOR APPROVAL: **RIVERSIDE COUNTY FLOOD CONTROL AND WATER CONSERVATION DISTRICT**

By _____
WARREN D. WILLIAMS
General Manager-Chief Engineer

By _____
MARION ASHLEY, Chairman
Riverside County Flood Control and Water
Conservation District Board of Supervisors

APPROVED AS TO FORM:

ATTEST:

PAMELA J. WALLS
County Counsel

KECIA HARPER-IHEM
Clerk of the Board

By _____
NEAL R. KIPNIS
Deputy County Counsel

By _____
Deputy

(SEAL)

Cooperative Agreement
Moreno Valley MDP Line F, Stage 2
Project No. 4-0-00752
12/17/12
TT:blj

1
2
3
4
5
6
7
8
9
10
11
12
13
14
15
16
17
18
19
20
21
22
23
24
25
26
27
28

RECOMMENDED FOR APPROVAL: **CITY OF MORENO VALLEY**

By _____
AHMAD ANSARI
Public Works Director/City Engineer

By _____
HENRY GARCIA
City Manager

APPROVED AS TO FORM:

ATTEST:

By _____
City Attorney

By _____
JANE HALSTEAD
City Clerk

(SEAL)

Cooperative Agreement
Moreno Valley MDP Line F, Stage 2
Project No. 4-0-00752
12/17/12
TT:blj

Exhibit A

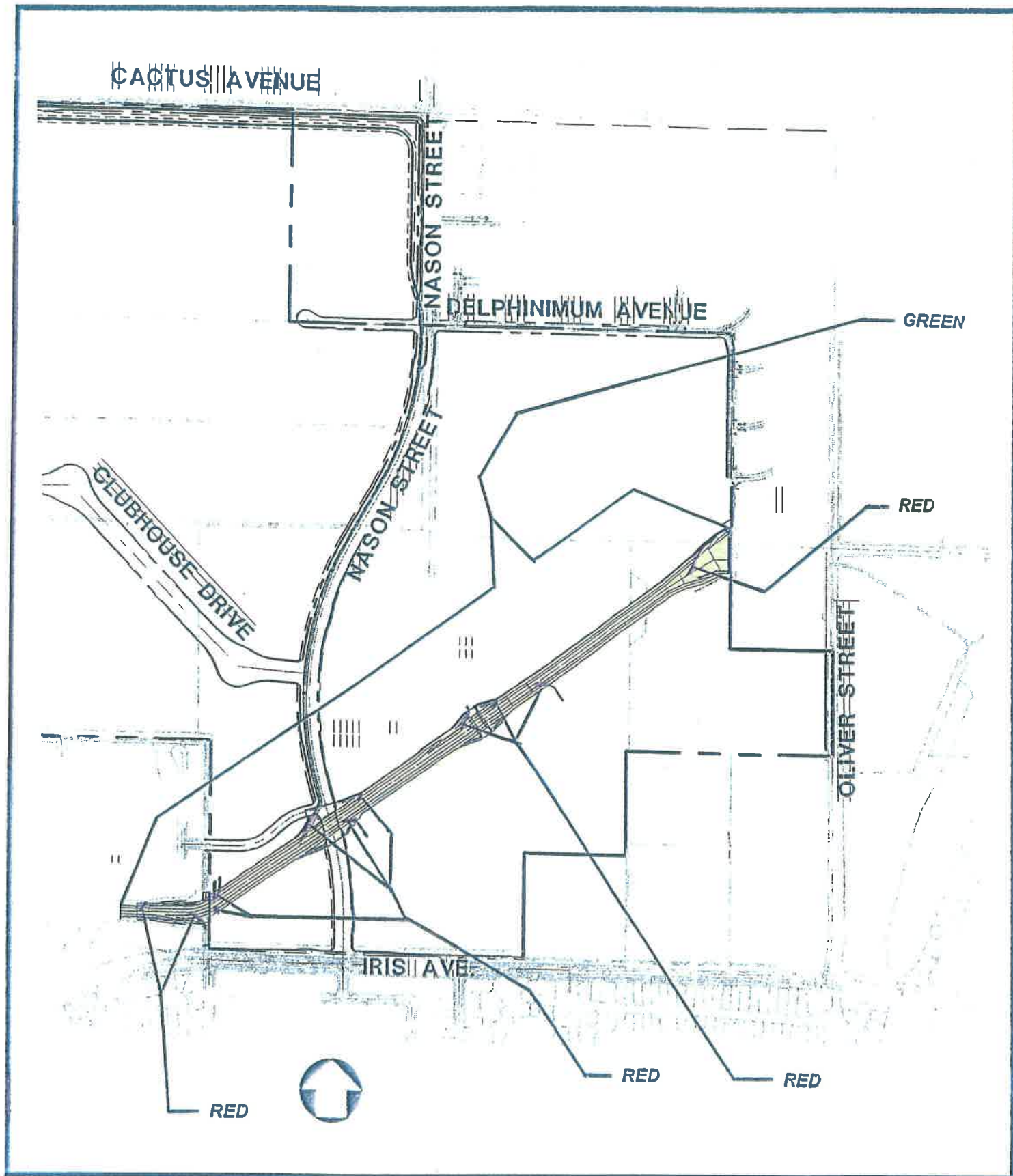

COOPERATIVE AGREEMENT
MORENO MDP LINE F, STAGE 2
A 00752

PAGE 1/1

Item No. A.8

Exhibit B

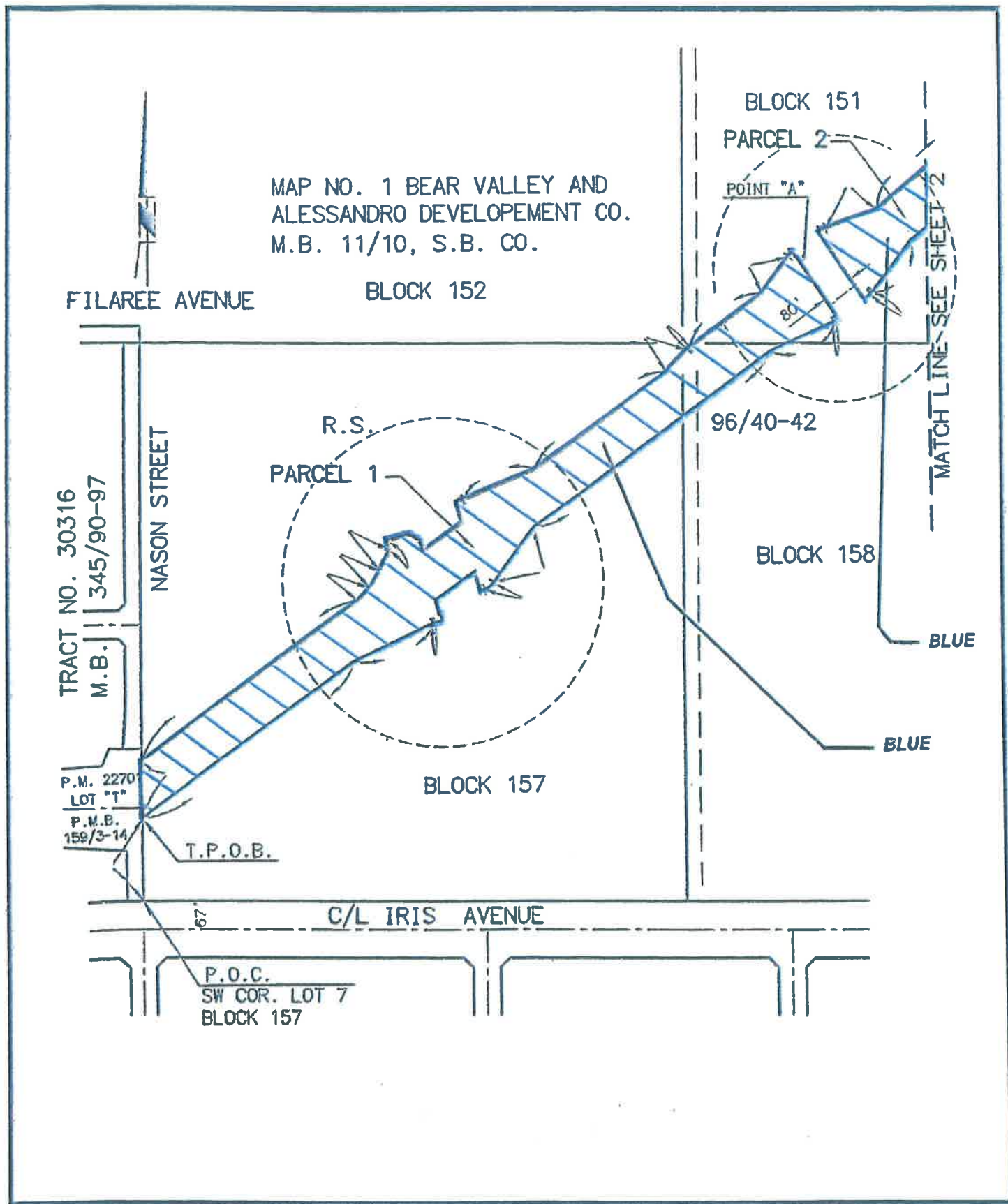

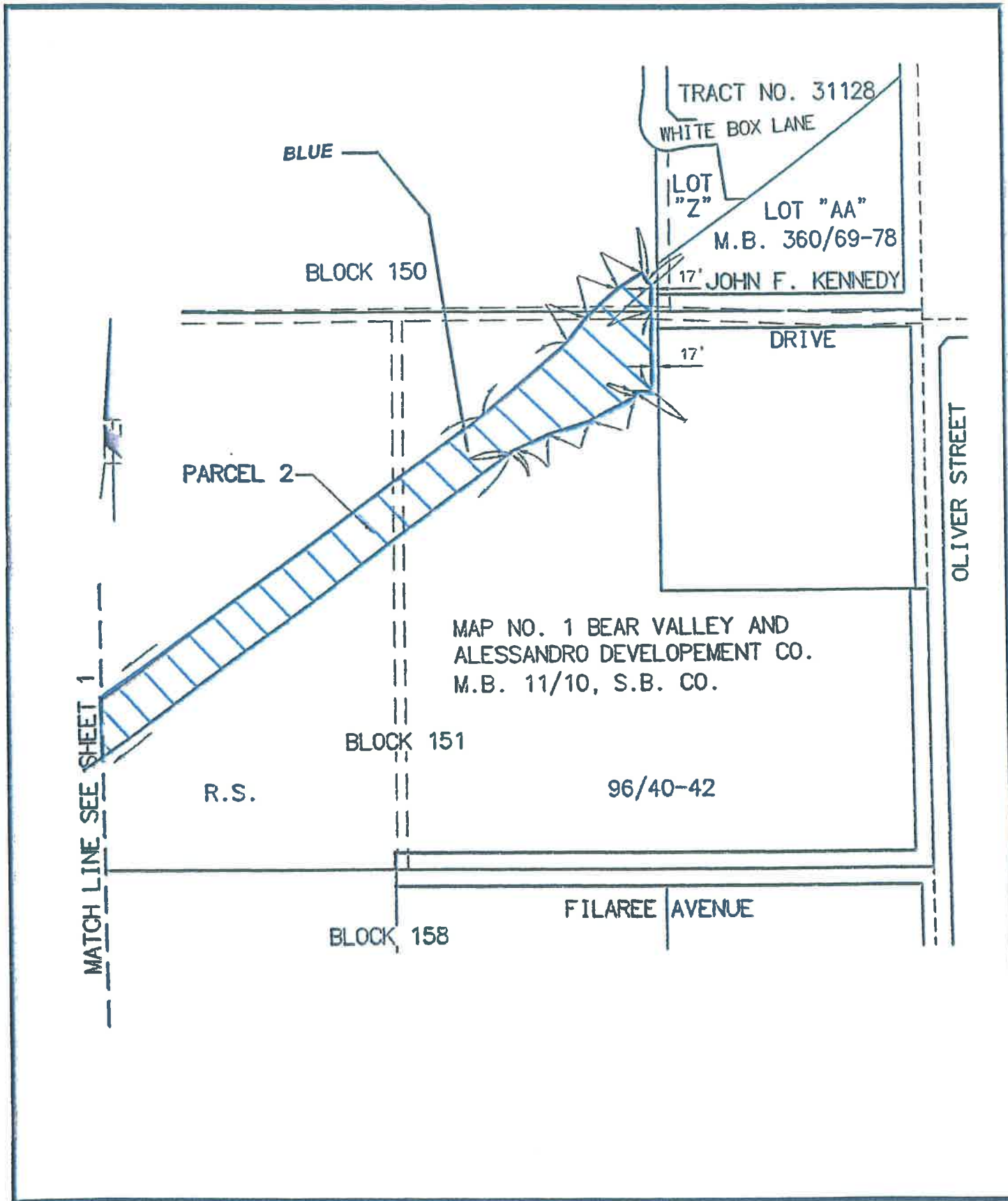

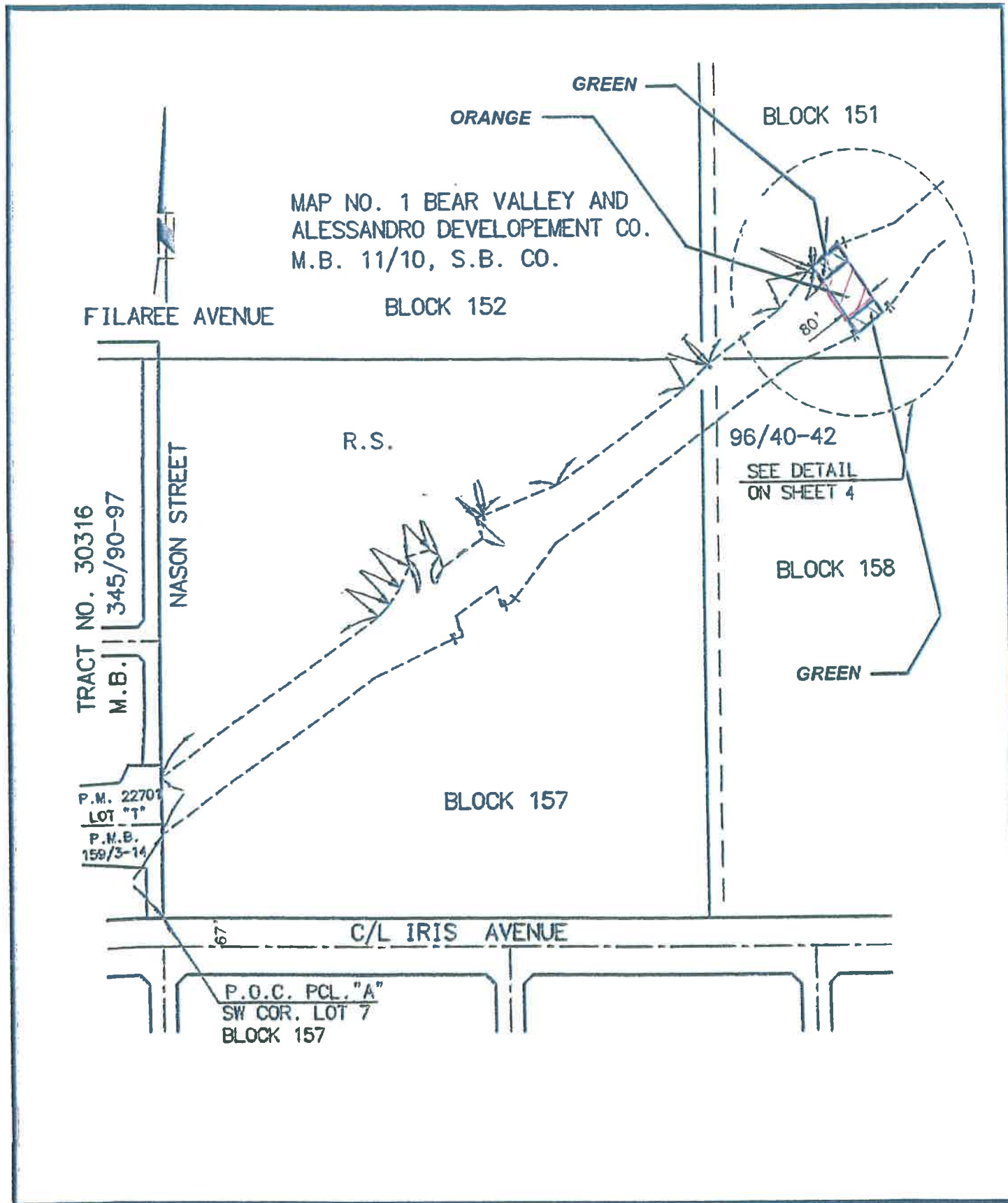

MAP NO. 1 BEAR VALLEY AND
ALESSANDRO DEVELOPEMENT CO.
M.B. 11/10, S.B. CO.

BLOCK 151

T.P.O.B.

CHANNEL "F"
DRAINAGE EASEMENT

ORANGE

MAP NO. 1 BEAR VALLEY AND
ALESSANDRO DEVELOPEMENT CO.
M.B. 11/10, S.B. CO.

BLOCK 151

T.P.O.B.
PCL. "A"

PARCEL "A"

GREEN

GREEN

POINT "A"
P.O.C.
PCL. "B"

80'

PARCEL "B"

ACCESS EASEMENT

T.P.O.B.
PCL. "B"

COOPERATIVE AGREEMENT
MORENO MDP LINE F, STAGE 2
4-0-00752

PAGE 4/8

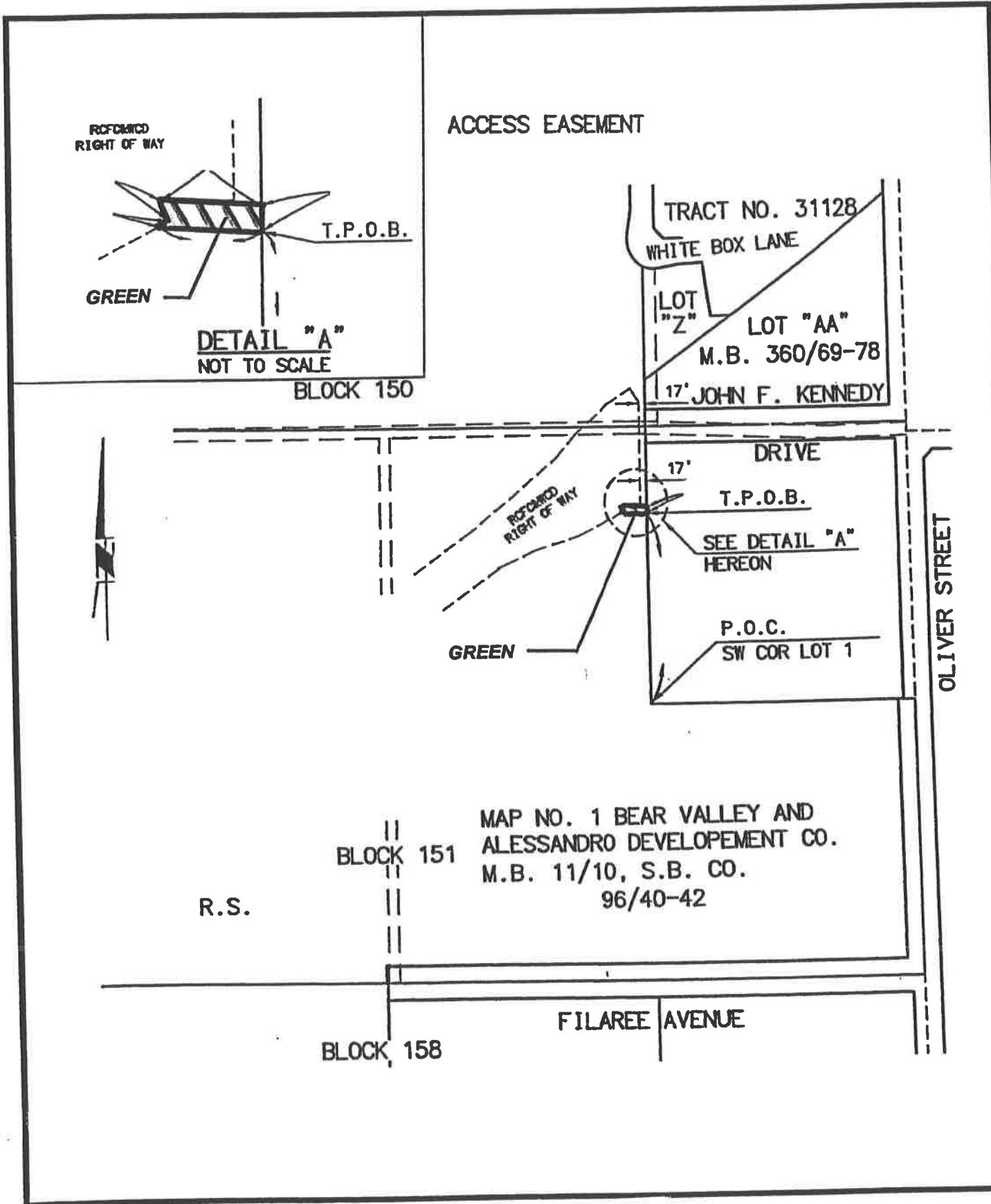

ACCESS EASEMENT

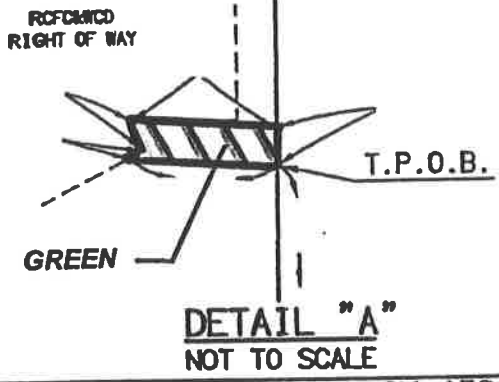

TRACT NO. 31128
 WHITE BOX LANE
 LOT "Z"
 LOT "AA"
 M.B. 360/69-78
 17' JOHN F. KENNEDY

DRIVE

T.P.O.B.

SEE DETAIL "A"
 HEREON

P.O.C.
 SW COR LOT 1

OLIVER STREET

BLOCK 151

MAP NO. 1 BEAR VALLEY AND
 ALESSANDRO DEVELOPEMENT CO.
 M.B. 11/10, S.B. CO.
 96/40-42

R.S.

BLOCK 158

FILAREE AVENUE

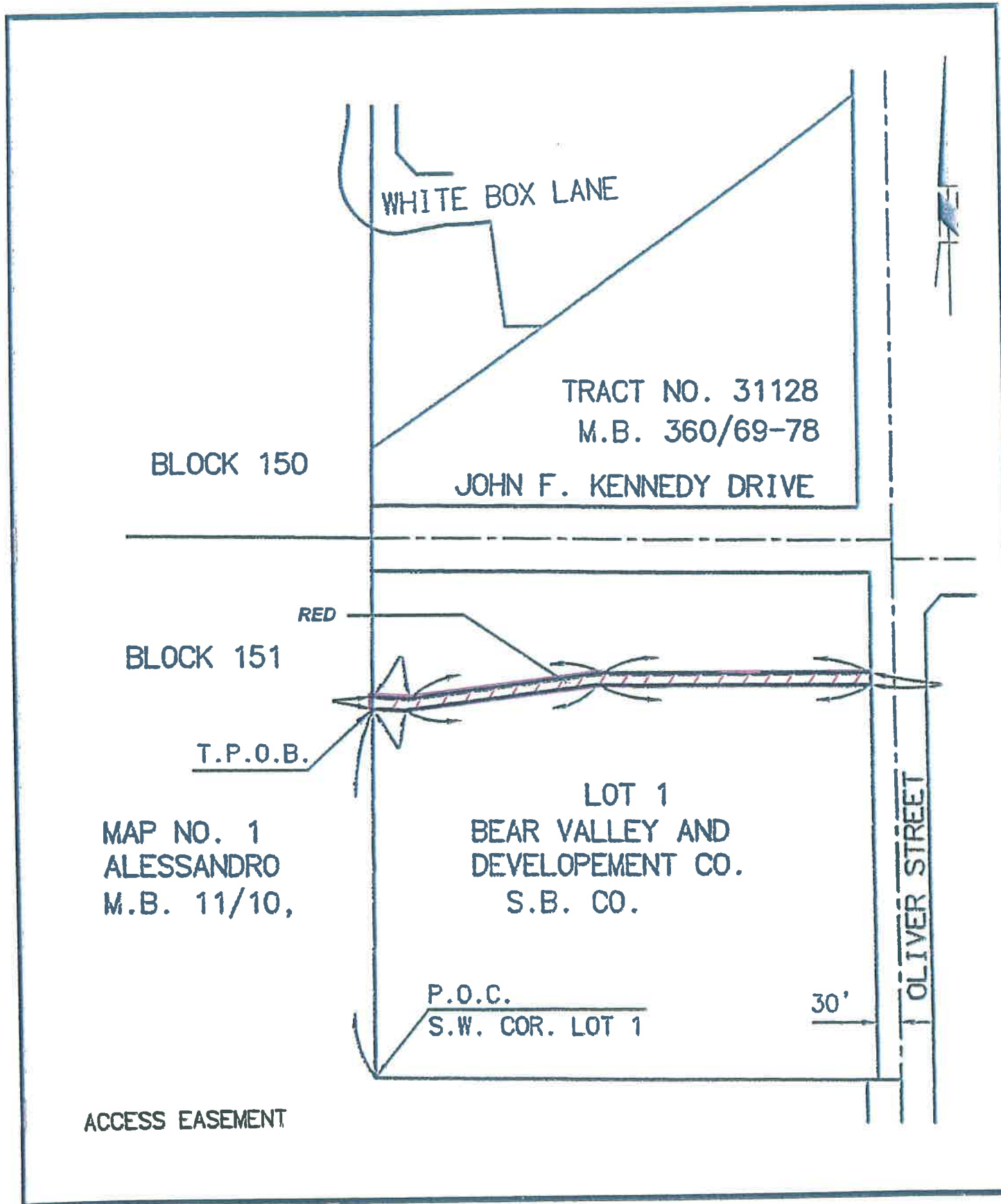

BLOCK 150

WHITE BOX LANE

TRACT NO. 31128
M.B. 360/69-78

JOHN F. KENNEDY DRIVE

BLOCK 151

RED

T.P.O.B.

MAP NO. 1
ALESSANDRO
M.B. 11/10,

LOT 1
BEAR VALLEY AND
DEVELOPEMENT CO.
S.B. CO.

P.O.C.
S.W. COR. LOT 1

30'

OLIVER STREET

ACCESS EASEMENT

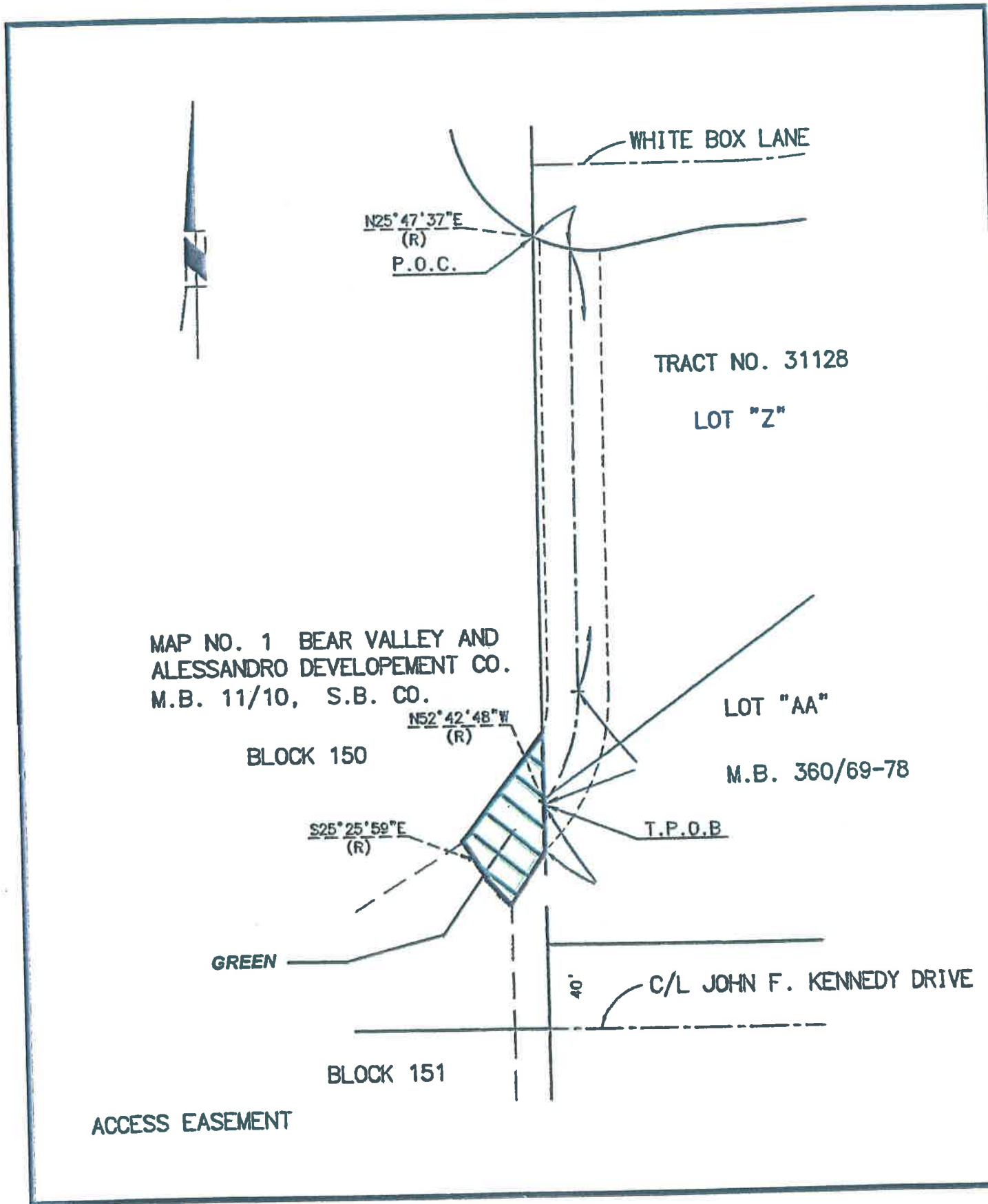

MAP NO. 1 BEAR VALLEY AND
ALESSANDRO DEVELOPEMENT CO.
M.B. 11/10, S.B. CO.

BLOCK 150

LOT "AA"

M.B. 360/69-78

$S25^{\circ}25'59"E$
(R)

T.P.O.B

GREEN

C/L JOHN F. KENNEDY DRIVE

BLOCK 151

ACCESS EASEMENT

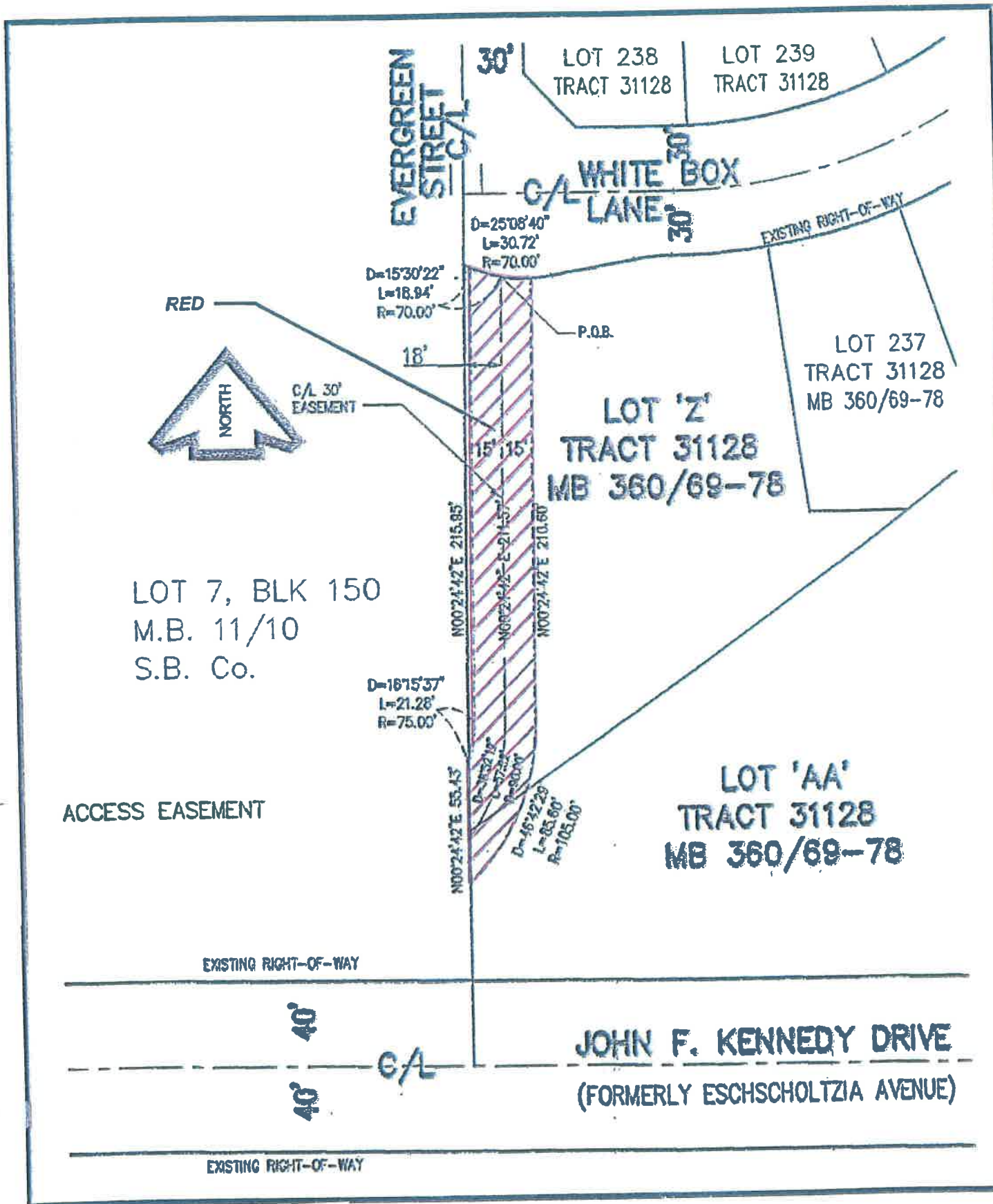

COOPERATIVE AGREEMENT
 MORENO MDP LINE F, STAGE
 2 4-0-00752

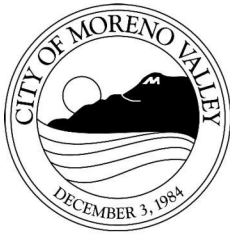

APPROVALS	
BUDGET OFFICER	<i>[Signature]</i>
CITY ATTORNEY	<i>[Signature]</i>
CITY MANAGER	<i>[Signature]</i>

Report to City Council

TO: Mayor and City Council

FROM: Ahmad R. Ansari, P.E., Public Works Director/City Engineer

AGENDA DATE: February 26, 2013

TITLE: REPEAL RESOLUTION NO. 2010-58 ENERGY EFFICIENCY TARGETS FOR MORENO VALLEY UTILITY AS MANDATED BY ASSEMBLY BILL 2021 AND ADOPT RESOLUTION NO. 2013-13 UPDATING ENERGY EFFICIENCY TARGETS FOR MORENO VALLEY UTILITY

RECOMMENDED ACTION

Recommendation:

1. Repeal Resolution No. 2010-58 and Approve Resolution No. 2013-13 Adopting the 2013 Moreno Valley Utility Energy Efficiency Targets. Resolution No. 2013-14 - A Resolution of the City Council of the City of Moreno Valley, California, to Repeal Resolution No. 2010-58 Energy Efficiency Targets for Moreno Valley Utility and Adopt the Updated 2013 Energy Efficiency Targets for the Moreno Valley Electric Utility Mandated by Assembly Bill 2021

ADVISORY BOARD/COMMISSION RECOMMENDATION

Not applicable.

BACKGROUND

California Assembly Bill 2021 (AB 2021) (Levine, Chapter 734, Statutes of 2006) was signed into law in September 2006. The statute requires that the California Energy Commission (CEC), in conjunction with the California Public Utility Commission (CPUC), and local Publicly-Owned Utilities (POUs), develop statewide estimates for energy efficiency targets in a public process. AB 2021 applies to all POUs in California. Pursuant to the statute, POUs must: 1) Identify all potentially achievable, cost-effective

energy efficiency savings; 2) Establish annual targets for energy efficiency savings and demand reduction over 10 years; and 3) Report targets, programs, expenditures, results and cost-effectiveness (including methodologies and independent evaluation) to governing members and to the California Energy Commission every three (3) years. POU's are mandated to consider energy efficiency as a preferred resource, estimate energy efficiency potential, and establish targets for achieving that potential.

In response to AB 2021, the members of California Municipal Utility Association (CMUA), Northern California Power Agency (NCPA), and Southern California Public Power Authority (SCPPA) joined together to collaborate on the development of individual utility energy efficiency and demand reduction targets. Initially in 2007, a total of 35 POU's, including MVU, participated in the development of the report. The collaboration included retaining Rocky Mountain Institute (RMI), an independent organization with well-accepted energy efficiency expertise in the energy industry. RMI's role was to establish a common, transparent tool used to determine utility specific energy efficiency projections. RMI's work provided the participating utilities with an independent, defensible methodology for analyzing energy efficiency potentials.

The members of CMUA, NCPA and SCPPA selected Navigant Consulting, also an independent organization with well-accepted energy efficiency in the energy industry, as the consultant for developing the energy efficiency models for 2010 and the 2013 updates. Workshops were held in July 2012 to help individual POU's update their individual targets for energy efficiency savings. The data for all participating utilities and summaries will be included in a report presented to the CEC in March 2013.

DISCUSSION

The City of Moreno Valley Electric Utility (MVU) was established in 2001 and began providing service to customers in 2004. Currently, MVU provides service to over 5,600 customers.

The selected consultant, Navigant Consulting compiled energy efficiency data submitted by MVU in their analytical tool and adjusted the data to the age of the utility and utilized various methods to update the calculations of potential energy savings. The consortium of POU's and two Joint Power Authorities, together with Navigant Consulting, identified both potential cost effective energy efficiency targets and demand reduction targets for each of the participating agencies.

The recommended annual energy efficiency and demand reduction targets for MVU is 0.18% of retail sales through 2023. MVU will pursue the most cost-effective programs and target the loads with the largest potential for reductions to meet or exceed these targets.

ALTERNATIVES

1. Approve and adopt the proposed resolution accepting the Energy Efficiency Targets developed through a collaboration of the City of Moreno Valley Electric

Utility, Navigant Consulting, CMUA, NCPA and SCPPA. *The approval of the resolution will have no direct monetary impact to the City.*

2. Do not adopt 2013 MVU 10-year energy efficiency portfolio plan as required by AB 2021 and do not approve the proposed resolution accepting the Energy Efficiency Targets developed through a collaboration of the City of Moreno Valley Electric Utility, Navigant Consulting, CMUA, NCPA and SCPPA. *This would result in the City paying an independent consultant for a study to develop energy efficiency targets completely independent of all the other Publicly-Owned Utilities in the State of California.*

FISCAL IMPACT

The cost of the CMUA report was \$7,000 and was paid in fiscal year 2011/2012.

CITY COUNCIL GOALS

POSITIVE ENVIRONMENT:

Create a positive environment for energy efficiency and potentially help contribute to the reduction of state’s reliance on fossil-fueled generation.

NOTIFICATION

Posting of Agenda.

ATTACHMENTS

Attachment: Proposed Resolution

Prepared By:
Michelle Pierce
Electric Utility Program Coordinator

Department Head Approval:
Ahmad R. Ansari, P.E.
Public Works Director/City Engineer

Concurred By:
Jeannette Olko
Electric Utility Manager

Council Action	
Approved as requested:	Referred to:
Approved as amended:	For:
Denied:	Continued until:
Other:	Hearing set for:

This page intentionally left blank.

RESOLUTION NO. 2013-13

A RESOLUTION OF THE CITY COUNCIL OF THE CITY OF MORENO VALLEY, CALIFORNIA, TO REPEAL RESOLUTION NO. 2010-58 ENERGY EFFICIENCY TARGETS FOR MORENO VALLEY UTILITY AND ADOPT THE UPDATED 2013 ENERGY EFFICIENCY TARGETS FOR THE MORENO VALLEY ELECTRIC UTILITY MANDATED BY ASSEMBLY BILL 2021

WHEREAS, the City of Moreno Valley (the "City"), a municipal corporation, is authorized pursuant to Article XI, Section 9(a) of the California Constitution to establish, purchase, and operate public works to furnish its inhabitants with light, water, power, heat, transportation, or means of communication; and

WHEREAS, on June 26, 2001, the City Council of the City of Moreno Valley approved Resolution No. 2001-33 and, as amended by Resolution No. 2002-46, authorized the formation of a municipally owned utility for the purpose of providing electrical power, storm water, telephone telecommunications, cable TV, water, natural gas, and sanitary sewer; and

WHEREAS, on September 26, 2006, California Assembly Bill 2021 (Levine) was signed into law which requires Publicly-Owned Utilities (POU) to identify all potentially achievable cost-effective electricity efficiency savings every three (3) years and establish annual targets for energy efficiency demand reduction for the next 10-year period; and

WHEREAS, the California Municipal Utilities Association (CMUA) in partnership with the Northern California Power Agency (NCPA) and the Southern California Public Power Authority (SCPPA) collaborated in the development of individual utility energy efficiency and demand reduction targets and submitted the initial report in 2007; and

WHEREAS, analytical methodology developed by Navigant Consulting was used by the majority of POU's in California to develop individual targets of reduction and peak demand; and

WHEREAS, the City of Moreno Valley Electric Utility updated the targets set for energy efficiency savings and set achievable goals for reducing peak demand.

1
Resolution No. 2013-13
Date Adopted: February 26, 2013

NOW, THEREFORE, THE CITY COUNCIL OF THE CITY OF MORENO VALLEY, CALIFORNIA, DOES HEREBY RESOLVE AS FOLLOWS:

1. The City Council hereby repeals Resolution No. 2010-58 Energy Efficiency Targets for Moreno Valley Utility and Adopts the Resolution Updating Energy Efficiency Targets for Moreno Valley Utility as mandated by AB 2021 to be 0.18% of retail sales through 2023.

APPROVED AND ADOPTED this 26th day of February, 2013.

Mayor of the City of Moreno Valley

ATTEST:

City Clerk

APPROVED AS TO FORM:

City Attorney

Resolution No. 2013-13²
Date Adopted: February 26, 2013

RESOLUTION JURAT

STATE OF CALIFORNIA)
COUNTY OF RIVERSIDE) ss.
CITY OF MORENO VALLEY)

I, Jane Halstead, City Clerk of the City of Moreno Valley, California, do hereby certify that Resolution No. 2013-13 was duly and regularly adopted by the City Council of the City of Moreno Valley at a regular meeting thereof held on the 26th day of February, 2013 by the following vote:

AYES:

NOES:

ABSENT:

ABSTAIN:

(Council Members, Mayor Pro Tem and Mayor)

CITY CLERK

(SEAL)

3
Resolution No. 2013-13
Date Adopted: February 26, 2013

This page intentionally left blank.

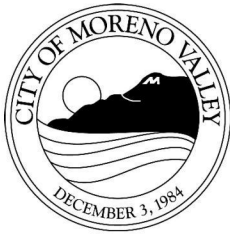

APPROVALS	
BUDGET OFFICER	
CITY ATTORNEY	
CITY MANAGER	

Report to City Council

TO: Mayor and City Council

FROM: Barry Foster, Community & Economic Development Director

AGENDA DATE: February 26, 2013

TITLE: SR 60 EAST CORRIDOR OVERLAY STUDY STATUS REPORT

RECOMMENDED ACTION

Recommendation:

1. Receive and file a status report for the SR 60 East Corridor Overlay Study.

ADVISORY BOARD/COMMISSION RECOMMENDATION

Not applicable.

BACKGROUND

On January 8, 2013, the City Council approved a budget appropriation to fund a consultant contract for the preparation of a SR 60 East Corridor Overlay Study (the "Study"). On January 22, 2013, the City Council adopted an interim moratorium ordinance for specified properties adjacent to State Highway 60 in the eastern portion of the City. The interim ordinance expires on March 8, 2013. An extension to the interim moratorium will be considered for up to an additional ten months and fifteen day period as a separate agenda item.

DISCUSSION

Pursuant to Government Code 65858(d), at least ten days prior to the expiration of the interim ordinance, the City Council shall issue a written report describing the measures taken to alleviate the condition which led to the adoption of the ordinance. The required status report is provided in the following section.

SR 60 East Corridor Overlay Study Status Report

Staff prepared a Request for Proposals (RFP) and consultant list for the Study. The RFP was distributed to the eighteen firms on the list on February 5, 2013. Responses to the RFP were due on February 19, 2013. As of the drafting of this report, no proposals have been received.

Staff will review all responses pursuant to standard practice for selection of a professional consultant. The selection process will focus on the capabilities of the consultant team and relevance of the responses to the criteria identified in the RFP. Pursuant to completion of the selection process, a recommendation for a consultant will be made to the City Manager for final approval. Staff will then negotiate and process approval of a consultant contract with the selected firm.

The approved consultant contract will include a definition of the final work product along with a preliminary schedule for completion of the contract. The final product is anticipated to be a recommended land use study, supported by economic analysis and compatibility with adjacent properties, for use by the Planning Commission and City Council in the review of future land use change proposals affecting the specified properties. At this time, the anticipated timeframe for completion is ninety days from the execution of the contract.

As directed by the City Council at the January 22, 2013, meeting, the first milestone for the consultant will be attendance at a City Council Study Session to allow for policy makers to provide input in advance of the preparation of the Study. The Planning Commission will be invited to participate in this discussion.

FISCAL IMPACT

At their January 22, 2013, meeting, the City Council allocated up to \$50,000 from the General Fund to cover the costs of the consultant contract.

Prepared By:
John C. Terrell AICP
Planning Official

Department Head Approval:
Barry Foster
Community & Economic Development Director

Council Action	
Approved as requested:	Referred to:
Approved as amended:	For:
Denied:	Continued until:
Other:	Hearing set for:



APPROVALS	
BUDGET OFFICER	<i>[Signature]</i>
CITY ATTORNEY	<i>[Signature]</i>
CITY MANAGER	<i>[Signature]</i>

Report to City Council

TO: Mayor and City Council

FROM: Thomas M. DeSantis, Administrative Services Director

AGENDA DATE: February 26, 2013

TITLE: MONTHLY REPORT: MORENO VALLEY ANIMAL SHELTER ADOPTION RATE

RECOMMENDED ACTION

Recommendation:

1. Receive and file the Monthly Report: Moreno Valley Animal Shelter Adoption Rate for the period of January 1, 2013 to January 31, 2013.

BACKGROUND

The City Council has challenged staff to increase adoption and decrease euthanasia rates at the Moreno Valley Animal Shelter. Ongoing evaluation of programs and services, along with increasing public awareness, will remain key elements to our success in increasing adoptions of homeless pets from our Shelter.

DISCUSSION

As a follow up to the December 18, 2012 City Council Study Session on Animal Shelter operations, Mayor Owings asked that monthly staff reports be prepared to keep the public informed of the City's progress and the ongoing need to increase pet adoptions and other programs to reduce the number of homeless animals euthanized.

CITY COUNCIL GOALS

Positive Environment: Create a positive environment for the development of Moreno Valley's future.

ATTACHMENTS

Attachment 1_2013_Moreno Valley Animal Shelter Intake/Disposition Report

Attachment 2_2013_Moreno Valley Animal Shelter Euthanasia Statistics

Prepared By:
Steve Fries
Animal Services Division Manager

Department Head Approval:
Thomas M. DeSantis
Administrative Services Director

Council Action	
Approved as requested:	Referred to:
Approved as amended:	For:
Denied:	Continued until:
Other:	Hearing set for:

**Moreno Valley Animal Shelter
Intake / Disposition Report – January 2013
Report Date 2/1/2013**

Intake	Dogs	Cats	Other	Total
Owner Surrender	45	15	1	61
Live Stray	488	111	9	608
Confiscated (Cruelty/Neglect/Aggressive)	2	0	0	2
Returns	8	1	0	9
Quarantine	2	1	0	3
DOAs	44	31	11	86
Total	589	159	21	769

Disposition	Dogs	Cats	Other	Total
On – Hand At Shelter 2/1/13	215	49	3	267
Escaped/Stolen	0	0	0	0
DOAs	44	31	11	86
Died in Kennel	2	1	0	3
Died at Vet	1	0	0	1
Foster	0	0	0	0
Euthanized	100	61	4	165*
Transfer	0	0	2	2**
Return to Owners	72	0	0	72**
Adopted	155	17	1	173**
Total	589	159	21	769

Summary Statistics: The statistics below reflect outcomes on the number of pets placed vs. those which could not be adopted. Figures are based upon the total number of pets available for placement, and does not reflect the number of animals which remained on-hand, or those which were deceased upon arrival and/or while under care. These categories are marked with * above. For the month of January 2013, the number of pets upon which statistics are calculated totaled: 412

Euthanasia Rates:	40% (165)	See Detailed Report
	Unadopted:	10% (16)
	Contagious Disease	34% (57)
	Medical/Behavioral/Other:	56% (92)

***Placement Rate: 60% (247) Reflects Return to Owners, Transfer, Adopted**

This page intentionally left blank.

**Moreno Valley Animal Shelter
January 2013 – Euthanasia Statistics**

Outcome Sub-Type	Dogs	Cats	Others	Total
Medical/Vet Rec.	21	15	4	40
Owner Requested	1	0	0	1
Contagious Disease	51	6	0	57
Feral	0	35	0	35
Aggressive Behavior Observed	13	3	0	16
Not Adopted*	14	2	0	16
Other				
Total	100	61	4	165

*Not Adopted: euthanized for considerations such as placement potential, time in shelter, humane considerations.

This page intentionally left blank.

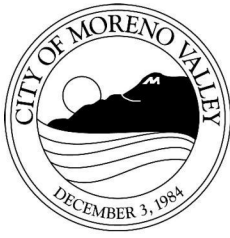

APPROVALS	
BUDGET OFFICER	
CITY ATTORNEY	
CITY MANAGER	

Report to City Council

TO: Mayor and City Council acting in their capacity as Successor Agency to the Community Redevelopment Agency of the City of Moreno Valley

FROM: Barry Foster, Community & Economic Development Director

AGENDA DATE: February 26, 2013

TITLE: RESOLUTION OF THE CITY OF MORENO VALLEY SERVING AS THE SUCCESSOR AGENCY FOR THE COMMUNITY REDEVELOPMENT AGENCY OF THE CITY OF MORENO VALLEY APPROVING THE RECOGNIZED OBLIGATION PAYMENT SCHEDULE FOR THE PERIOD OF JULY 1, 2013 THROUGH DECEMBER 31, 2013

RECOMMENDED ACTION

Recommendations:

1. Acting in the Capacity as the Successor Agency for the Community Redevelopment Agency of the City of Moreno Valley, Adopt Resolution No. SA 2013-02 approving a Recognized Obligation Payment Schedule (ROPS 13-14 A), for the period of July 1, 2013 through December 31, 2013.
2. Authorize the Executive Director or his designee to make modifications to the Schedule.
3. Authorize the transmittal of the ROPS 13-14 A ("Attachment 1") to the Oversight Board for review and approval.

ADVISORY BOARD/COMMISSION RECOMMENDATION

N/A

BACKGROUND

ABX1 26 requires the Successor Agency to approve a Recognized Obligation Payment Schedule (“ROPS”) for each six-month period. The required content of the ROPS, set forth in Health and Safety Code Section 34177(l)(1), details all of the Agency’s legally binding and enforceable obligations, anticipated payments, and sources of payments. Recognized obligations include bonds, loans, judgments, settlements, any legally binding and enforceable agreements or contracts, and contracts and agreements for agency administration or operation

AB 1484 further clarifies certain matters associated with the dissolution of RDAs and addresses substantive issues related to administrative processes, affordable housing activities, and repayment of loans from communities, use of existing bond proceeds, and the disposition or retention of former RDA assets.

The City of Moreno Valley is the Successor Agency for the Community Redevelopment Agency of the City of Moreno Valley (RDA) pursuant to Part 1.85 of Division 24 of the Health and Safety Code. As Successor Agency, the City is responsible for winding down the affairs of the redevelopment agency including disposing of its assets; making payments and performing other obligations due for Enforceable Obligations of the former RDA. In order to facilitate the process, on February 28, 2012, the City Council adopted Resolution No. 2012-13 approving a Recognized Obligation Payment Schedule for the period of January 1, 2012 through June 30, 2012, and on April 10, 2012, adopted Resolution No. 2012-22, approving a Second Recognized Obligation Payment Schedule (Original “ROPS 2”) for the period of July 1, 2012 through December 31, 2012. Most recently, on August 28, 2012, the City Council adopted Resolution No. 2012-71 approving a Third Recognized Obligation Payment Schedule (Original “ROPS 3”) for the period of January 1, 2013 through June 30, 2013.

DISCUSSION

Enforceable Obligation Payment Schedule

In accordance with ABX1 26, the Successor Agency is required to adopt an Enforceable Obligation Payment Schedule (“EOPS”). The EOPS lists all of the Agency’s legally binding and enforceable agreement obligations and anticipated payments. Enforceable obligations include bonds, loans, judgments, settlements, any legally binding and enforceable agreements or contracts, and contracts and agreements for agency administration or operation costs.

Section 34177(a)(1) of ABX1 26 provides that upon the dissolution of the Agency, the Successor Agency may only make those payments required pursuant to the most recent Enforceable Obligation Payment Schedule adopted by the Agency and the Successor Agency, and until such time the Recognized Obligation Payment Schedule becomes operative.

Recognized Obligation Payment Schedule

ABX1 26 requires the Successor Agency to approve a Recognized Obligation Payment Schedule (“ROPS”). The ROPS supersedes the EOPS, and is required for each six-month period.

Similar to the EOPS, the required content of the ROPS, set forth in Health and Safety Code Section 34177(l)(1), details all of the Agency’s legally binding and enforceable obligations, anticipated payments, and sources of payments. Recognized obligations include bonds, loans, judgments, settlements, any legally binding and enforceable agreements or contracts, and contracts and agreements for agency administration or operation costs. The attached ROPS 13-14 A sets forth the enforceable obligations for the period of July 1, 2013 through December 31, 2013.

Once approved, the ROPS 13-14 A will be submitted to the Oversight Board for review and approval. Upon approval by the Oversight Board, a copy of the approved ROPS will be transmitted to the County-Auditor Controller, the State Controller’s Office, the Department of Finance, and posted to the City’s website.

ALTERNATIVES

1. Adopt the attached proposed resolution, which approve the Recognized Obligation Payment Schedule for the period of July 1, 2013 through December 31, 2013, and authorizing the transmittal of said Schedules to the Oversight Board for review and approval. *Staff recommends this alternative because it allows the City serving as the Successor Agency to make required debt service payments in accordance with the State legislation.*
2. Decline to adopt the attached proposed resolution which would not allow the City, serving as the Successor Agency, to maintain the operations, and fulfill debt obligations of the former RDA as required by law. *Staff does not recommend this alternative.*

FISCAL IMPACT

The Recognized Obligation Payment Schedule provides the details necessary for the City serving as the Successor Agency to fulfill the former RDA’s legally binding and enforceable agreements. The ROPS 13-14 A will serve as authorization to pay obligations listed during the noted period. There will be some impact to the General Fund to absorb costs that are no longer paid by the former Redevelopment Agency for either RDA administration or operations and for Low and Moderate Income Housing Fund work. Staff estimates that this cost will be approximately \$100,000 for fiscal year 2013-2014.

SUMMARY

As Successor Agency, the City is responsible for winding down the affairs of the redevelopment agency including disposing of its assets; making payments and performing other obligations due for Enforceable Obligations of the former RDA. The Recognized Obligation Payment Schedules for the stated periods provides the details necessary for the City serving as the Successor Agency to fulfill the former RDA’s legally binding and enforceable agreements as required by law.

NOTIFICATION

No public notice is required prior to the City Council taking action on this item. However, the agenda for the meeting during which this item may be considered has been posted in the three locations that have been designated for the posting of City Council agendas.

ATTACHMENTS

Attachment 1 – Proposed Resolution
 Exhibit A -Recognized Obligation Payment Schedule (ROPS 13-14 A)

Prepared By:
 Anochar Clark
 Sr. Financial Analyst

Department Head Approval:
 Barry Foster
 Community & Economic Development
 Director

Concurred by:
 Dante Hall
 Business Support & Neighborhood Programs Administrator

Council Action	
Approved as requested:	Referred to:
Approved as amended:	For:
Denied:	Continued until:
Other:	Hearing set for:

RESOLUTION NO. SA 2013-02

A RESOLUTION OF THE CITY COUNCIL OF THE CITY OF MORENO VALLEY SERVING AS SUCCESSOR AGENCY TO THE COMMUNITY REDEVELOPMENT AGENCY OF THE CITY OF MORENO VALLEY APPROVING THE RECOGNIZED OBLIGATION PAYMENT SCHEDULE FOR THE PERIOD OF JULY 1, 2013 THROUGH DECEMBER 31, 2013, AND AUTHORIZING THE EXECUTIVE DIRECTOR OR HIS DESIGNEE TO MAKE MODIFICATIONS THERETO

WHEREAS, the Community Redevelopment Agency of the City of Moreno Valley ("Agency") is a community redevelopment agency organized and existing under the California Community Redevelopment Law, Health and Safety Code Sections 33000, et seq. ("CRL") and has been authorized to transact business and exercise the powers of a redevelopment agency pursuant to action of the City Council ("City Council") of the City of Moreno Valley ("City"); and

WHEREAS, the Agency was established pursuant to the Redevelopment Law. The Agency was activated on February 18, 1986, by City Ordinance No. 50. The City Council adopted and approved the Redevelopment Plan for the Project Area by Ordinance 87-154 of the City on December 29, 1987 (the "Original Plan"), as subsequently amended by Ordinance No. 448 of the City adopted January 10, 1995, Ordinance No. 556 of the City adopted December 14, 1999, and Ordinance No. 732 adopted December 19, 2006 (as so amended, the "Amended Redevelopment Plan", the area of which is referred to herein as the "Project Area"); and

WHEREAS, Parts 1.8, 1.85 and 1.9 of Division 24 of the Health and Safety Code were added to the CRL by ABX1 26 and ABX1 27, which measures purport to become effective immediately. ABX1 26 and ABX1 27, which are trailer bills to the 2011-12 budget bills, were approved by both houses of the Legislature on June 15, 2011 and signed by the Governor on June 28, 2011; and

WHEREAS, Part 1.85 of the CRL ("Part 1.85") provides for the statewide dissolution of all redevelopment agencies, including the Agency, as of October 1, 2011 (which dated has been deemed to be February 1, 2012 pursuant to a decision by the California Supreme Court), and provides that, thereafter, a successor agency to administer the enforceable obligations of the Agency and otherwise wind up the Agency's affairs, all subject to the review and approval by an oversight committee; and

WHEREAS, Part 1.8 of the CRL ("Part 1.8") provides for the restriction of activities and authority of the Agency in the interim period prior to dissolution to certain "enforceable obligations" and to actions required for the general winding up of affairs, preservation of assets, and certain other goals delineated in Part 1.8; and

WHEREAS, in connection with the implementation of those provisions of ABX1 26 which require the adoption of an enforceable obligation schedule, the City

1
Resolution No. SA 2013-02
Date Adopted: February 26, 2013

serving as the Successor Agency has previously adopted an amended enforceable obligation schedule in the form previously submitted (the "Amended Enforceable Obligation Schedule") and has authorized the City Manager or his designee to augment, modify or revise such Amended Enforceable Obligation Schedule; and

WHEREAS, ABX1 26 further requires the adoption of an Initial Recognized Obligation Payment Schedule; such initial Recognized Obligation Payment Schedule was approved by Resolution No. 2012-13 of the City of Moreno Valley serving as Successor Agency to the Community Redevelopment Agency of the City of Moreno Valley ("Successor Agency") on February 28, 2012.

WHEREAS, ABX1 26 further requires the adoption of a Recognized Obligation Payment Schedule for every six month period;

WHEREAS, an oversight board, as provided under ABX1 26 ("Oversight Board") has been established for the former Agency;

WHEREAS, pursuant to ABX1 26 and the implementation thereof, the Successor Agency desires to adopt a Recognized Obligation Payment Schedule for the period covering July 1, 2013 through December 31, 2013 ("ROPS 13-14 A"), in the form submitted herewith. The ROPS 13-14 A is attached hereto, marked as Exhibit "A", and is incorporated herein by reference. By this resolution, the City Council, on behalf of the Successor Agency, approves and authorizes the transmittal of the ROPS 13-14 A to the Oversight Board;

WHEREAS, given the adoption of ABX1 26, the City Council, on behalf of the City acting in its capacity as Successor Agency to the Agency, has duly considered this Resolution and has determined that the adoption of this Resolution is in the best interests of the City, in its capacity as Successor Agency to the Agency, and the health, safety, and welfare of the residents of the City, and in accord with the public purposes and provisions of applicable state and local laws and requirements.

NOW, THEREFORE, THE CITY COUNCIL OF THE CITY OF MORENO VALLEY, SERVING AS THE SUCCESSOR AGENCY, DOES HEREBY RESOLVE AS FOLLOWS:

SECTION 1. The foregoing recitals are incorporated into this resolution by this reference, and constitute a material part of this resolution.

SECTION 2. The Successor Agency approves for transmittal to the Oversight Board the Recognized Obligation Payment Schedule for the period July 1, 2013 through December 31, 2013 ("Exhibit A"), with such augmentation, modification, additions or revisions as the Executive Director of the Successor Agency or his designee may make before transmittal to the Oversight Board.

2
Resolution No. 2013-02
Date Adopted: February 26, 2013

SECTION 3. The Successor Agency is authorized and directed to submit ROPS 13-14 A to the California Department of Finance upon approval by the Oversight Board.

SECTION 4. The Successor Agency shall maintain on file as a public record this Resolution and ROPS 13-14 A as approved hereby.

SECTION 5. This Resolution shall be effective immediately upon adoption.

SECTION 6. The City Clerk shall certify to the adoption of this resolution.

APPROVED AND ADOPTED this 26th day of February 2013.

Mayor of the City of Moreno Valley

ATTEST:

City Clerk

APPROVED AS TO FORM:

City Attorney

3
Resolution No. 2013-02
Date Adopted: February 26, 2013

RESOLUTION JURAT

STATE OF CALIFORNIA)
COUNTY OF RIVERSIDE) ss.
CITY OF MORENO VALLEY)

I, Jane Halstead, City Clerk of the City of Moreno Valley, California, do hereby certify that Resolution No. SA 2013-02 was duly and regularly adopted by the City Council of the City of Moreno Valley at a regular meeting thereof held on the 26th day of February, 2013 by the following vote:

AYES:

NOES:

ABSENT:

ABSTAIN:

(Council Members, Mayor Pro Tem and Mayor)

CITY CLERK

(SEAL)

4
Resolution No. 2013-02
Date Adopted: February 26, 2013

SUCCESSOR AGENCY CONTACT INFORMATION

Successor Agency

ID: **234**
 County: **Riverside**
 Successor Agency: **Moreno Valley**

Primary Contact

Honorific (Ms, Mr, Mrs)	
First Name	Annie
Last Name	Clark
Title	Sr. Financial Analyst
Address	14177 Frederick Str
City	Moreno Valley
State	CA
Zip	92552
Phone Number	951-413-3475
Email Address	anocharc@moval.org

Secondary Contact

Honorific (Ms, Mr, Mrs)	
First Name	Richard
Last Name	Teichert
Title	Financial and Administrative Services Director
Phone Number	951-413-3021
Email Address	richardt@moval.org

SUMMARY OF RECOGNIZED OBLIGATION PAYMENT SCHEDULE

Filed for the July 1, 2013 to December 31, 2013 Period

Name of Successor Agency: MORENO VALLEY (RIVERSIDE)

Outstanding Debt or Obligation	Total
Total Outstanding Debt or Obligation	\$128,940,501

Current Period Outstanding Debt or Obligation	Six-Month Total
A Available Revenues Other Than Anticipated RPTTF Funding	\$0
B Enforceable Obligations Funded with RPTTF	\$2,589,505
C Administrative Allowance Funded with RPTTF	\$125,000
D Total RPTTF Funded (B + C = D)	\$2,714,505
E Total Current Period Outstanding Debt or Obligation (A + B + C = E) <i>Should be same amount as ROPS form six-month total</i>	\$2,714,505
F Enter Total Six-Month Anticipated RPTTF Funding	\$2,714,505
G Variance (F - D = G) <i>Maximum RPTTF Allowable should not exceed Total Anticipated RPTTF Funding</i>	\$0

Prior Period (July 1, 2012 through December 31, 2012) Estimated vs. Actual Payments (as required in HSC section 34186 (a))	
H Enter Estimated Obligations Funded by RPTTF <i>(lesser of Finance's approved RPTTF amount including admin allowance or the actual amount distributed)</i>	\$2,537,358
I Enter Actual Obligations Paid with RPTTF	\$2,055,008
J Enter Actual Administrative Expenses Paid with RPTTF	\$125,000
K Adjustment to Redevelopment Obligation Retirement Fund (H - (I + J) = K)	\$357,350
L Adjustment to RPTTF (D - K = L)	\$2,357,155

Certification of Oversight Board Chairman:

Pursuant to Section 34177(m) of the Health and Safety code,

I hereby certify that the above is a true and accurate Recognized

Obligation Payment Schedule for the above named agency.

_____	_____
Name	Title
/s/ _____	_____
Signature	Date

MORENO VALLEY (RIVERSIDE)
 RECOGNIZED OBLIGATION PAYMENT SCHEDULE (ROPS 13-14A)
 July 1, 2013 through December 31, 2013

Oversight Board Approval Date: _____

Item #	Project Name / Debt Obligation	Contract/Agreement Execution Date	Contract/Agreement Termination Date	Payee	Description/Project Scope	Project Area	Total Outstanding Debt or Obligation	Total Due During Fiscal Year 2013-14	Funding Source					Six-Month Total
									Bond Proceeds	Reserve Balance	Admin Allowance	RPTTF	Other	
									\$0	\$0	\$125,000	\$2,589,505	\$0	\$2,714,505
1	2007 Tax Allocation Bonds			Wells Fargo Bank	Debt service payments for bonds issued to finance various capital projects	Original Area	77,151,538	2,254,284	0	0	0	0	0	0
2	2007 Special Tax Refunding Bonds - Towngate 87-1			Wells Fargo Bank	Debt service payments for bonds issued to finance the acquisition of public facilities	Original Area	9,546,333	1,182,347	0	0	0	591,174	0	591,174
3	Improvement Area No. 1 Special Tax Refunding Bonds			Wells Fargo Bank	Debt service payments for bonds issued to finance the construction of public facilities	Original Area	2,804,116	277,181	0	0	0	138,591	0	138,591
4	CFD No. 3 - Auto Mall Refinance			Wells Fargo Bank	Debt service payments for bonds issued to finance the construction of public facilities	Original Area	2,000,061	109,451	0	0	0	54,725	0	54,725
5	2011 Refunding of 97 LRB Bonds			Bank of America	Debt service payments for bonds issued to finance the construction of a public facility	Original Area	1,350,000	150,000	0	0	0	75,000	0	75,000
6	2005 Lease Revenue Bonds			Wells Fargo Bank	Debt service payments for bonds issued to finance Sunnymead Blvd project	Original Area	12,940,788	594,773	0	0	0	184,699	0	184,699
7	On-going Housing Monitoring Requirements			City of Moreno Valley/Successor Agency	Costs to perform the recertification and monitoring of housing units	Original Area	0	0	0	0	0	0	0	0
8	Contract for Legal Services	12/16/2008		Stradling, Yocca, Carlson & Rauth	Legal services - General	Original Area	72,000	72,000	0	0	0	36,000	0	36,000
9	Contract for Legal Services	5/8/2012		Kronick Moskovitz Tiedemann & Girard	Legal services - Oversight Board Legal Counsel	Original Area	36,000	36,000	0	0	0	18,000	0	18,000
10	Contract for Abatement of Properties	7/1/2009		Fire Prevention/Inland Empire Property Service, Inc.	Nuisance/weed abatement of Agency owned properties	Original Area	7,500	7,500	0	0	0	3,750	0	3,750
11	Contract for Audit Services	2/10/2011		Lance Soll & Iunghard, LLP or Approved Audit Firm	Preparation of Required Due Dilligent Reviews and Annual Audit	Original Area	20,000	20,000	0	0	0	10,000	0	10,000
12	Contract for Special Tax Reporting	1/1/2011		Willdan/Staff Administration	Preparation of Continuing Disclosure Report	Original Area	5,000	5,000	0	0	0	2,500	0	2,500
13	CalPERS Retirement Liability			The California Public Employees' Retirement System (CalPERS)	Unfunded PERS Retirement Liability Acct	Original Area	587,103	13,855	0	0	0	13,855	0	13,855
14	Retiree Medical Trust (CERBT)			California Employers' Retiree Medical Trust(CERBT)/CalPERS	Unfunded Retiree Medical Trust Acct	Original Area	184,297	4,462	0	0	0	4,462	0	4,462
15	Agency Loans #1 & # 2	1/23/2007		City of Moreno Valley	City/Agency Loan Agreement	Original Area	0	0	0	0	0	0	0	0
16	Price Club Acquisition Note	5/7/1992	5/7/2015	The Price Family Charitable Fund	Participation Agreement	Original Area	989,800	480,000	0	0	0	240,000	0	240,000
17	Towngate Acquisition Note	5/3/2004		City of Moreno Valley	Participation Agreement	Original Area	15,980,964	555,000	0	0	0	250,000	0	250,000
18	Moss Bros. Autogroup Participation Agreement	5/25/2010	11/25/2010	Moss Bros. Autogroup	Participation Agreement	Original Area	0	0	0	0	0	0	0	0
19	Robertson's Ready Mix, Inc. OPA	9/26/2006		Robertson's Ready Mix, Inc.	Owner Participation Agreement	Original Area	4,000,000	0	0	0	0	0	0	0
20	Hemlock Family Apartments	3/8/2011		Rancho Belago, Inc.	Affordable Housing Agreement	Original Area	1,000,000	0	0	0	0	943,000	0	943,000
21	Rancho Dorado Apts - South (Second Phase)	3/8/2011		Moreno Valley Housing Authority/MV Rancho Dorado Limited Partnership	Affordable Housing Agreement	Original Area	0	0	0	0	0	0	0	0
22	Rancho Dorado Apts - South (Second Phase)	12/16/2008		Stradling, Yocca, Carlson & Rauth	Legal services - Specific to Affordable Housing Agreement w/ Rancho Dorado Apts.	Original Area	10,000	5,000	0	0	0	2,500	0	2,500
23	Rancho Dorado Apts - South (Second Phase)	9/2/2009		Strickler Association	Title & Closing Costs	Original Area	5,000	2,500	0	0	0	1,250	0	1,250
24	Payroll Costs/Operating Costs			City of Moreno Valley/Employees	Successor Agency's Payroll & Operating Costs	Original Area	250,000	250,000	0	0	125,000	0	0	125,000
25	Sunnymead Blvd. CIP 79221	8/3/2009	8/20/2010	Excel	Capital Project Contract, CIP 79221	Original Area	0	0	0	0	0	20,000	0	20,000
26	Sunnymead Blvd. CIP 79221	2/6/2008	2/28/2011	Harris & Assoc.	Capital Project Contract, CIP 79221	Original Area	0	0	0	0	0	0	0	0
27	Sunnymead Blvd. CIP 79221			City of Moreno Valley, cost allocation, and extra admin. costs	Project Management CIP 79221	Original Area	0	0	0	0	0	0	0	0
28	Sunnymead Blvd. CIP 79221			City Consultants	Project Management CIP 79221	Original Area	0	0	0	0	0	0	0	0

-245-

Item No. A.12

Oversight Board Approval Date: _____

MORENO VALLEY (RIVERSIDE)
 RECOGNIZED OBLIGATION PAYMENT SCHEDULE (ROPS 13-14A)
 July 1, 2013 through December 31, 2013

Item #	Project Name / Debt Obligation	Contract/Agreement Execution Date	Contract/Agreement Termination Date	Payee	Description/Project Scope	Project Area	Total Outstanding Debt or Obligation	Total Due During Fiscal Year 2013-14	Funding Source					Six-Month Total
									Bond Proceeds	Reserve Balance	Admin Allowance	RPTTF	Other	
29	Sunnymead Blvd. CIP 79221			Gibbs, Giden, Locher, Turner & Senet LLP	Additional Legal Fees - CIP 79221	Original Area	0	0	0	0	0	0	0	0
30	Storm Drain/Day Street to Cottonwood CIP 79222			Gibbs, Giden, Locher, Turner & Senet	Contractual Services PO# 42123 CIP 79222	Original Area	0	0	0	0	0	0	0	0
31	Storm Drain/Day Street to Cottonwood CIP 79222			City of Moreno Valley	Project Management CIP 79222	Original Area	0	0	0	0	0	0	0	0
32	Day Street/Alessandro Blvd to Cottonwood CIP 79724	5/2/2011	12/31/2012	DMC Design	Contractual Services PO#40920 CIP 79724	Original Area	0	0	0	0	0	0	0	0
33	Day Street/Alessandro Blvd to Cottonwood CIP 79724			AEI-CASC	Contractual Services PO#35423 CIP 79724	Original Area	0	0	0	0	0	0	0	0
34	Day Street/Alessandro Blvd to Cottonwood CIP 79724			Group Delta	Contractual Services PO#39328 CIP 79724	Original Area	0	0	0	0	0	0	0	0
35	Day Street/Alessandro Blvd to Cottonwood CIP 79724			KDM Meridian	Contractual Services PO#41865 CIP 79724	Original Area	0	0	0	0	0	0	0	0
36	Day Street/Alessandro Blvd to Cottonwood CIP 79724			STI Inc.	Contractual Services PO#41859 CIP 79724	Original Area	0	0	0	0	0	0	0	0
37	Day Street/Alessandro Blvd to Cottonwood CIP 79724			City of Moreno Valley	Project Management CIP 79724	Original Area	0	0	0	0	0	0	0	0
38	Auto Mall Street Upgrades CIP 79725	3/21/2012	12/31/2012	VA Consulting	Capital Project Contract, CIP 79725	Original Area	0	0	0	0	0	0	0	0
39	Auto Mall Street Upgrades CIP 79725			City of Moreno Valley	Project Management CIP 79725	Original Area	0	0	0	0	0	0	0	0
40	Auto Mall Street Upgrades CIP 79725	1/26/2012	12/31/2012	United Inspection (Geotech)	Capital Project Contract, CIP 79725	Original Area	0	0	0	0	0	0	0	0
41	Auto Mall Street Upgrades CIP 79725	12/15/2012	12/31/2012	VA Consulting Inc. (Survey)	Capital Project Contract, CIP 79725	Original Area	0	0	0	0	0	0	0	0
42	Auto Mall Street Upgrades CIP 79725	3/26/2012		SME&C (Contractor)	Capital Project Contract, CIP 79725	Original Area	0	0	0	0	0	0	0	0
43	Indian Basin, Appurtenant CIP 79726	7/15/2008	12/31/2012	Ulm & Nascimento Engineering	Contractual Services PO#35828 CIP 79726	Original Area	0	0	0	0	0	0	0	0
44	Indian Basin, Appurtenant CIP 79726			City of Moreno Valley, cost allocation, and minor expenses	Project Management CIP 79726	Original Area	0	0	0	0	0	0	0	0
45	Ironwood Ave-Day St/Barclay Dr CIP 79727	6/12/2008	3/31/2013	AEI-CASC Engineering	Capital Project Contract, CIP 79727	Original Area	0	0	0	0	0	0	0	0
46	Ironwood Ave-Day St/Barclay Dr CIP 79727			City of Moreno Valley, cost allocation, and minor expenses	Project Management CIP 79727	Original Area	0	0	0	0	0	0	0	0
47	Ironwood Ave-Day St/Barclay Dr CIP 79727			Contractor	Capital Project Contract, CIP 79727	Original Area	0	0	0	0	0	0	0	0
48	Ironwood Ave-Day St/Barclay Dr CIP 79727			Survey Consultant	Project Management CIP 79727	Original Area	0	0	0	0	0	0	0	0
49	Ironwood Ave-Day St/Barclay Dr CIP 79727			Geotechnical Consultant	Capital Project Contract, CIP 79727	Original Area	0	0	0	0	0	0	0	0
50	Ironwood Ave-Day St/Barclay Dr CIP 79727			Southern California Edison	Project Management CIP 79727	Original Area	0	0	0	0	0	0	0	0

MORENO VALLEY (RIVERSIDE)
 RECOGNIZED OBLIGATION PAYMENT SCHEDULE (ROPS 13-14A)
 July 1, 2013 through December 31, 2013

Oversight Board Approval Date: _____

Item #	Project Name / Debt Obligation	Contract/Agreement Execution Date	Contract/Agreement Termination Date	Payee	Description/Project Scope	Project Area	Total Outstanding Debt or Obligation	Total Due During Fiscal Year 2013-14	Funding Source					Six-Month Total
									Bond Proceeds	Reserve Balance	Admin Allowance	RPTTF	Other	
51	Nason/SR-60 Bridge CIP 79718			Singer & Coffin, APC	Legal services CIP 79718	Original Area	0	0	0	0	0	0	0	0
52	Nason/SR-60 Bridge CIP 79718			City of Moreno Valley	Project Management and associated costs CIP 79718	Original Area	0	0	0	0	0	0	0	0
53	Nason/SR-60 Bridge CIP 79718			Staff Consultants	Project Management CIP 79718	Original Area	0	0	0	0	0	0	0	0
54	Nason/SR-60 Bridge CIP 79718			Moreno Valley Utility	Lighting CIP 79718	Original Area	0	0	0	0	0	0	0	0
55	Nason/SR-60 Bridge CIP 79718	7/7/2010		Caltrans	State-furnished materials CIP 79718	Original Area	0	0	0	0	0	0	0	0
56	Nason/SR-60 Bridge CIP 79718	7/7/2010		Caltrans	State source inspection fees CIP 79718	Original Area	0	0	0	0	0	0	0	0
57	Nason/SR-60 Bridge CIP 79718	7/7/2010		CHP	Construction zone enforcement (COZEEP) CIP 79718	Original Area	0	0	0	0	0	0	0	0
58	Nason/SR-60 Bridge CIP 79718	6/21/2011	12/31/2014	Parsons Transportation	Design-related costs CIP 79718	Original Area	0	0	0	0	0	0	0	0
59	Nason/SR-60 Bridge CIP 79718	5/21/2012	6/30/2015	Falcon Engineering	Construction mgmt and Inspection Services CIP 79718	Original Area	0	0	0	0	0	0	0	0
60	Nason/SR-60 Bridge CIP 79718			Contractor	Construction Contract CIP 79718	Original Area	0	0	0	0	0	0	0	0
61	Nason/SR-60 Bridge CIP 79718			Survey Consultant	Construction Services - Survey CIP 79718	Original Area	0	0	0	0	0	0	0	0
62	Nason/SR-60 Bridge CIP 79718			Geotechnical Consultant	Construction Services - Geotechnical CIP 79718	Original Area	0	0	0	0	0	0	0	0
63	Nason/SR-60 Bridge CIP 79718			SCE	Utility relocation CIP 79718	Original Area	0	0	0	0	0	0	0	0
64	Nason/SR-60 Bridge CIP 79718			EMWD	Permits/Fees, CIP 79718	Original Area	0	0	0	0	0	0	0	0
65	Nason/SR-60 Bridge CIP 79718			RCFC&WCD	Permits/Fees, CIP 79718	Original Area	0	0	0	0	0	0	0	0
66	Moreno Beach Ramps - Phase 1 CIP 79731			City of Moreno Valley	Project Management and associated costs CIP 79731	Original Area	0	0	0	0	0	0	0	0
67	Moreno Beach Ramps - Phase 1 CIP 79731			City of Moreno Valley	City-furnished equipment - CIP 79731	Original Area	0	0	0	0	0	0	0	0
68	Moreno Beach Ramps - Phase 1 CIP 79731			City of Moreno Valley	Project Management and associated costs CIP 79731	Original Area	0	0	0	0	0	0	0	0
69	Moreno Beach Ramps - Phase 1 CIP 79731	6/21/2011	12/31/2014	Parsons Transportation	Design-related costs CIP 79731	Original Area	0	0	0	0	0	0	0	0
70	Moreno Beach Ramps - Phase 1 CIP 79731	4/30/2012	12/31/2014	Parsons Transportation	Construction support CIP 79731	Original Area	0	0	0	0	0	0	0	0
71	Moreno Beach Ramps - Phase 1 CIP 79731	3/8/2012	2/28/2013	Falcon Engineering	Constructability review CIP 79731	Original Area	0	0	0	0	0	0	0	0
72	Moreno Beach Ramps - Phase 1 CIP 79731	7/16/2012	6/30/2015	Falcon Engineering	Construction mgmt and Inspection Services CIP 79731	Original Area	0	0	0	0	0	0	0	0
73	Moreno Beach Ramps - Phase 1 CIP 79731			So. Calif. Edison	Utility Relocation CIP 79731	Original Area	0	0	0	0	0	0	0	0
74	Moreno Beach Ramps - Phase 1 CIP 79731	1/4/2012		Caltrans	State-furnished materials CIP 79731	Original Area	0	0	0	0	0	0	0	0
75	Moreno Beach Ramps - Phase 1 CIP 79731	1/4/2012		Caltrans	State source inspection fees CIP 79731	Original Area	0	0	0	0	0	0	0	0

MORENO VALLEY (RIVERSIDE)
 Pursuant to Health and Safety Code section 34186 (a)
PRIOR PERIOD ESTIMATED OBLIGATIONS vs. ACTUAL PAYMENTS
RECOGNIZED OBLIGATION PAYMENT SCHEDULE (ROPS II)
 July 1, 2012 through December 31, 2012

Item #	Project Name / Debt Obligation	Payee	Description/Project Scope	Project Area	LMIHF		Bond Proceeds		Reserve Balance		Admin Allowance		RPTTF		Other	
					Estimate	Actual	Estimate	Actual	Estimate	Actual	Estimate	Actual	Estimate	Actual	Estimate	Actual
					\$1,700,000	\$1,700,000	\$4,326,563	\$3,519,675	\$1,834,465	\$1,829,215	\$125,000	\$134,807	\$2,412,358	\$2,055,008	\$0	\$0
1)	Improvement Area No. 1 Special Tax Refunding Bonds	Wells Fargo Bank	Debt service payments for bonds issued to finance the construction of public facilities	Original Area									138,013	138,013		
2)	CFD No. 3 - Auto Mall Refinance	Wells Fargo Bank	construction of public facilities	Original Area									17,569	17,569		
3)	2011 Refunding of 97 LRB Bonds	Bank of America	construction of a public facility	Original Area									75,000	75,000		
4)	2005 Lease Revenue Bonds	Wells Fargo Bank	Sunnymead Blvd project	Original Area									404,799	404,799		
5)	On-going Housing Monitoring Requirements	City of Moreno Valley/Successor Agency	Costs to perform the recertification and monitoring of housing units	Original Area									20,000	0		
6)	Contract for Legal Services	Stradling, Yocca, Carlson & Rauth	Legal services - General	Original Area									36,000	36,105		
7)	Contract for Legal Services	Kronick Moskowitz Tiedemann & Girard	Legal services - Oversight Board Legal Counsel	Original Area									36,000	4,991		
8)	Contract for Abatement of Properties	Property Service, Inc.	Nuisance/weed abatement of Agency owned properties	Original Area									5,000	934		
9)	Contract for Special Tax Reporting	Willdan/Staff Administration	Preparation of Continuing Disclosure Report	Original Area									2,500	0		
10)	CalPERS Retirement Liability	Retirement System (CalPERS)	Unfunded PERS Retirement Liability Acct	Original Area									13,855	13,855		
11)	Retiree Medical Trust (CERBT)	Medical Trust(CERBT)/CalPERS	Unfunded Retiree Medical Trust Acct	Original Area									4,462	4,462		
12)	Agency Loans #1 & #2	City of Moreno Valley	City/Agency Loan Agreement	Original Area									0	0		
13)	Conference & Recreation Cntr Agreement	Wells Fargo Bank	Debt service payments/Purchase and Sale Agreement	Original Area									0	0		
14)	Price Club Acquisition Note	The Price Family Charitable Fund	Participation Agreement	Original Area									240,000	240,131		
15)	Towngate Acquisition Note	City of Moreno Valley	Participation Agreement	Original Area									240,000	247,603		
16)	Gastus/Day/Dkt 215 Land	City of Moreno Valley	Land purchased - Account Payable	Original Area									0	0		
17)	Agreement	Moss Bros. Autogroup	Participation Agreement	Original Area									250,000	250,000		
18)	Robertson's Ready Mix, Inc. OPA	Robertson's Ready Mix, Inc.	Owner Participation Agreement	Original Area									0	0		
19)	Hemlock Family Apartments	Rancho Belago, Inc.	Affordable Housing Agreement	Original Area									0	0		
20)		(MVHA)	Affordable Housing Agreement	Original Area									600,000	600,000		
21)	Rancho Dorado Apts - South	Stradling, Yocca, Carlson & Rauth	Rancho Dorado Apts	Original Area									12,500	12,500		
22)		Strickler Association	Title & Closing Costs	Original Area									2,500	2,500		
1)		Excel*	Capital Project Contract, CIP 79221	Original Area									50,000	50,000		
2)	Sunnymead Blvd.	Harris & Assoc.*	Capital Project Contract, CIP 79221	Original Area									176,000	176,000		
3)	CIP 79221	City of Moreno Valley	Project Management CIP 79221	Original Area									12,300	115		
4)		City Consultants	Project Management CIP 79221	Original Area									1,960	1,960		
5)		Senet LLP*	Additional Legal Fees - CIP 79221	Original Area									66,000	5,116		
6)	Storm Drain/Day Street to Cottonwood	Senet*	Contractual Services PO# 42123 CIP 79222	Original Area									6,205	4,015		
7)	CIP 79222	City of Moreno Valley	Project Management CIP 79222	Original Area									1,695	12,300		
8)		DMC Design	Contractual Services PO#40920 CIP 79724	Original Area				5,881								
9)		AEI-CASC	Contractual Services PO#35423 CIP 79724	Original Area				8,776								
10)	Day Street/Alessandro Blvd to Cottonwood	Group Delta	Contractual Services PO#39328 CIP 79724	Original Area				7,359								
11)	CIP 79724	KDM Meridian	Contractual Services PO#41865 CIP 79724	Original Area				3,993								
12)		STI Inc.	Contractual Services PO#41859 CIP 79724	Original Area				73,322								
13)		City of Moreno Valley	Project Management CIP 79724	Original Area				20,395	13,960							
14)		VA Consulting	Capital Project Contract, CIP 79725	Original Area				2,333	2,724							
15)		City of Moreno Valley	Project Management CIP 79725	Original Area				6,451	12,031							
16)	Auto Mall Street Upgrades	United Inspection (Geotech)	Capital Project Contract, CIP 79725	Original Area				1,575								
17)	CIP 79725	VA Consulting Inc. (Survey)	Capital Project Contract, CIP 79725	Original Area				1,650								
18)		SME&C (Contractor)	Capital Project Contract, CIP 79725	Original Area				190,379	205,809							
19)	Indian Basin, Appurtenant	Lim & Nascimento Engineering	Contractual Services PO#35828 CIP 79726	Original Area				50,000	85,388							
20)	CIP 79726	City of Moreno Valley	Project Management CIP 79726	Original Area				20,000								
21)	Ironwood Ave-Day St/Barclay Dr	AEI-CASC Engineering	Capital Project Contract, CIP 79727	Original Area				25,872	11,743							
22)	CIP 79727	City of Moreno Valley	Project Management CIP 79727	Original Area				6,000	12,554							
23)		Singer & Coffin, APC	Legal Services CIP 79718	Original Area				770								
24)		Parsons Transportation	Contractual Services CIP 79718 - Design	Original Area				0	451,466							
25)		City Consultants	Project Management CIP 79718	Original Area				950	150							
26)		City of Moreno Valley	Project Management CIP 79718	Original Area				33,795	48,373							
27)		Peomas	Capital Project Contract, CIP 79718	Original Area				10,000								
28)	Nason/SR-60 Bridge	Riverside Construction Co.	Capital Project Contract, CIP 79718	Original Area				1,000,000								

-249-

Item No. A.12

MORENO VALLEY (RIVERSIDE)
 Pursuant to Health and Safety Code section 34186 (a)
PRIOR PERIOD ESTIMATED OBLIGATIONS vs. ACTUAL PAYMENTS
RECOGNIZED OBLIGATION PAYMENT SCHEDULE (ROPS II)
 July 1, 2012 through December 31, 2012

Item #	Project Name / Debt Obligation	Payee	Description/Project Scope	Project Area	LMIHF		Bond Proceeds		Reserve Balance		Admin Allowance		RPITF		Other	
					Estimate	Actual	Estimate	Actual	Estimate	Actual	Estimate	Actual	Estimate	Actual	Estimate	Actual
					\$1,700,000	\$1,700,000	\$4,326,563	\$3,519,675	\$1,834,465	\$1,829,215	\$125,000	\$134,807	\$2,412,358	\$2,055,008	\$0	\$0
29)	CIP 79718	Falcon Engineering - CM	Capital Project Contract, CIP 79718	Original Area			110,000	5,940								
30)		Leighton Consulting Inc.	Capital Project Contract, CIP 79718	Original Area			10,000									
31)		City of Moreno Valley	Project Management CIP 79718	Original Area			20,000									
		Gibbs, Giden, Locher, Turner & Senet*	Legal Fees - CIP 79718	Original Area			833	1,449								
32)		Parsons Transportation	Construction support CIP 79718	Original Area			10,000									
33)		City of Moreno Valley	Project Management CIP 79729	Original Area			159,145	59,213								
34)		STK Architecture	Capital Project Contract, CIP 79729	Original Area			93,811	76,322								
35)	Morrison Park Fire Station	Silver Creek Industries	Capital Project Contract, CIP 79729	Original Area			1,814,956	7,054,889								
36)	CIP 79729	Enco Utility	Capital Project Contract, CIP 79729	Original Area			417	3,840								
37)		Riverside County IT	Capital Project Contract, CIP 79729	Original Area			13,210	16,561								
38)		Construction Contract	Construction Costs CIP 79729	Original Area			351,865	36,123								
39)		City of Moreno Valley	Project Management and associated costs CIP 79731	Original Area			64,125	60,193								
40)		Staff Consultants	Capital Project Contract CIP 79731	Original Area			2,100	1,353								
41)		Coory Engineering	Capital Project Contract CIP 79731	Original Area			10,000									
42)		Falcon Engineering - CM	Capital Project Contract CIP 79731	Original Area			99,544	74,871								
43)	Moreno Beach Ramps - Phase 1	Ninyo & Moore Geotechnical	Capital Project Contract CIP 79731	Original Area			10,000									
44)	CIP 79731	CHP	Const. zone enforcement CIP 79731	Original Area			30,000									
45)		EMWD	Permits/Fees, CIP 79731	Original Area			19,000	19,000								
46)		Gibbs, Giden, Locher, Turner & Senet*	Legal Fees - CIP 79731	Original Area			1,000									
47)		Parsons Transportation	Design/Construction/Landscape-related costs CIP 79731	Original Area			37,055	265,723								
46)	2007 Tax Allocation Bonds****	Wells Fargo Bank	Debt service payments for bonds issued to finance various capital projects*	Original Area					1,246,892	1,241,642						
47)	2007 Special Tax Refunding Bonds - Towngate 87-1****	Wells Fargo Bank	Debt service payments for bonds issued to finance the acquisition of public facilities*	Original Area					587,573	587,573						
48)	Rancho Dorado Apts - South*	Moreno Valley Housing Authority (MVHA)	Affordable Housing Agreement	Original Area	1,700,000	1,700,000										
1	City/Agency Employee Payroll	City of Moreno Valley/Employees	Payroll Costs	Original Area							125,000	134,807				

MORENO VALLEY (RIVERSIDE)
RECOGNIZED OBLIGATION PAYMENT SCHEDULE (ROPS 13-14A) – Notes (Optional)
July 1, 2013 through December 31, 2013

Item #	Project Name / Debt Obligation	Notes/Comments
1	2007 Tax Allocation Bonds	
2	2007 Special Tax Refunding Bonds - Towngate 87-1	
3	Improvement Area No. 1 Special Tax Refunding Bonds	
4	CFD No. 3 - Auto Mall Refinance	
5	2011 Refunding of 97 LRB Bonds	
6	2005 Lease Revenue Bonds	
7	On-going Housing Monitoring Requirements	
8	Contract for Legal Services	
9	Contract for Legal Services	
10	Contract for Abatement of Properties	
11	Contract for Audit Services	
12	Contract for Special Tax Reporting	
13	CalPERS Retirement Liability	
14	Retiree Medical Trust (CERBT)	
15	Agency Loans #1 & # 2	
16	Price Club Acquisition Note	
17	Towngate Acquisition Note	
18	Moss Bros. Autogroup Participation Agreement	
19	Robertson's Ready Mix, Inc. OPA	
20	Hemlock Family Apartments	
21	Rancho Dorado Apts - South (Second Phase)	
22	Rancho Dorado Apts - South (Second Phase)	
23	Rancho Dorado Apts - South (Second Phase)	
24	Payroll Costs/Operating Costs	
25	Sunnymead Blvd. CIP 79221	Litigation Pending.
26	Sunnymead Blvd. CIP 79221	Litigation Pending.
27	Sunnymead Blvd. CIP 79221	Litigation Pending.
28	Sunnymead Blvd. CIP 79221	Litigation Pending.
29	Sunnymead Blvd. CIP 79221	Litigation Pending.
30	Storm Drain/Day Street to Cottonwood CIP 79222	Litigation Pending.
31	Storm Drain/Day Street to Cottonwood CIP 79222	Litigation Pending.
32	Day Street/Alessandro Blvd to Cottonwood CIP 79724	The project is complete.
33	Day Street/Alessandro Blvd to Cottonwood CIP 79724	The project is complete.
34	Day Street/Alessandro Blvd to Cottonwood CIP 79724	The project is complete.
35	Day Street/Alessandro Blvd to Cottonwood CIP 79724	The project is complete.
36	Day Street/Alessandro Blvd to Cottonwood CIP 79724	The project is complete.
37	Day Street/Alessandro Blvd to Cottonwood CIP 79724	The project is complete.
38	Auto Mall Street Upgrades CIP 79725	The project is complete.
39	Auto Mall Street Upgrades CIP 79725	The project is complete.
40	Auto Mall Street Upgrades CIP 79725	The project is complete.
41	Auto Mall Street Upgrades CIP 79725	The project is complete.

MORENO VALLEY (RIVERSIDE)
RECOGNIZED OBLIGATION PAYMENT SCHEDULE (ROPS 13-14A) – Notes (Optional)
July 1, 2013 through December 31, 2013

Item #	Project Name / Debt Obligation	Notes/Comments
42	Auto Mall Street Upgrades CIP 79725	The project is complete.
43	Indian Basin, Appurtenant CIP 79726	The project is complete.
44	Indian Basin, Appurtenant CIP 79726	The project is complete.
45	Ironwood Ave-Day St/Barclay Dr CIP 79727	The project is complete.
46	Ironwood Ave-Day St/Barclay Dr CIP 79727	The project is complete.
47	Ironwood Ave-Day St/Barclay Dr CIP 79727	The project is complete.
48	Ironwood Ave-Day St/Barclay Dr CIP 79727	The project is complete.
49	Ironwood Ave-Day St/Barclay Dr CIP 79727	The project is complete.
50	Ironwood Ave-Day St/Barclay Dr CIP 79727	The project is complete.
51	Nason/SR-60 Bridge CIP 79718	The project is complete.
52	Nason/SR-60 Bridge CIP 79718	The project is complete.
53	Nason/SR-60 Bridge CIP 79718	The project is complete.
54	Nason/SR-60 Bridge CIP 79718	The project is complete.

**MINUTES - REGULAR MEETING OF FEBRUARY 12, 2013
(Report of: City Clerk Department)**

Recommendation: Approve as submitted.

SEE AGENDA ITEM A.2

This page intentionally left blank.

**MINUTES - REGULAR MEETING OF FEBRUARY 12, 2013
(Report of: City Clerk Department)**

Recommendation: Approve as submitted.

SEE AGENDA ITEM A.2

This page intentionally left blank.

**MINUTES - REGULAR MEETING OF FEBRUARY 12, 2013
(Report of: City Clerk Department)**

Recommendation: Approve as submitted.

SEE AGENDA ITEM A.2

This page intentionally left blank.

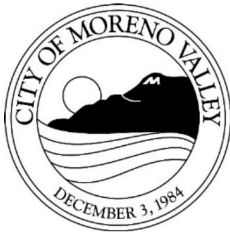

APPROVALS	
BUDGET OFFICER	<i>[Signature]</i>
CITY ATTORNEY	<i>[Signature]</i>
CITY MANAGER	<i>[Signature]</i>

Report to City Council

TO: Mayor and City Council

FROM: Suzanne Bryant, Acting City Attorney

AGENDA DATE: February 26, 2013

TITLE: PUBLIC HEARING TO ADOPT AN INTERIM URGENCY ORDINANCE OF THE CITY OF MORENO VALLEY, CALIFORNIA, MAKING FINDINGS AND EXTENDING A MORATORIUM ON THE ISSUANCE OF LAND USE ENTITLEMENT IN FOUR DESIGNATED LOCATIONS ALONG THE SR-60 EAST CORRIDOR AREA

RECOMMENDED ACTION

Recommendation: That the City Council:

1. Conduct a Public Hearing to allow the public an opportunity to comment on the proposed Interim Urgency Ordinance.
2. Adopt Interim Urgency - Ordinance No. 861 - An Interim Urgency Ordinance of the City of Moreno Valley, California, making findings and extending a moratorium on the Issuance of Land Use Entitlements in four designated locations along the SR-60 East corridor area.

ADVISORY BOARD/COMMISSION RECOMMENDATION

N/A.

BACKGROUND

During the discussion regarding the preparation of a land use overlay (Item G.1.) at the January 8, 2013 City Council meeting, the City Council directed that a moratorium be placed on the January 22, 2013 agenda for the four designated locations along the SR-60 East corridor area that will be studied by a planning consultant.

At the January 22, 2013 City Council meeting, the Council adopted an interim urgency ordinance that prohibits any land use entitlements in the four designated areas for a 45 day period while the planning consultant is retained and begins to conduct the study. The interim urgency ordinance adopted on January 22, 2013 can only be in effect 45 days from its date of adoption.

DISCUSSION

Staff, in a separate agenda item, has provided a status update on what has happened since the interim urgency ordinance was adopted. The Council can extend the interim ordinance for 10 months and 15 days so that the study for the four designated areas may continue. While the ordinance adopted on January 22, 2013 can only be in effect for 45 days, it can be extended for 10 months and 15 days upon further Council action. Therefore, this item has been set for a public hearing to consider the extension of the interim urgency ordinance. In order to extend the interim urgency ordinance a four-fifths vote of the Council is required.

ALTERNATIVES

If the Council chooses not to extend the interim urgency ordinance, it will automatically expire 45 days after January 22, 2013 (March 8, 2013).

FISCAL IMPACT

No known fiscal impacts to the City.

CITY COUNCIL GOALS

Positive Environment. Create a positive environment for the development of Moreno Valley's future.

SUMMARY

The City Council, at their January 8, 2013 meeting directed that a moratorium be placed on the January 22, 2013 agenda. At the January 22, 2013 Council meeting, the urgency interim ordinance was adopted for a 45 day period. Extending the moratorium by the attached ordinance will require a minimum of a four-fifths vote.

NOTIFICATION

Posting of the agenda and publication in the newspaper.

ATTACHMENTS

Attachment 1 – Proposed Ordinance

Prepared By:
Suzanne Bryant
Acting City Attorney

Department Head Approval:
Suzanne Bryant
Acting City Attorney

Council Action	
Approved as requested:	Referred to:
Approved as amended:	For:
Denied:	Continued until:
Other:	Hearing set for:

This page intentionally left blank.

ORDINANCE NO. 861

AN INTERIM URGENCY ORDINANCE OF THE CITY OF MORENO VALLEY, CALIFORNIA, MAKING FINDINGS AND EXTENDING A MORATORIUM ON THE ISSUANCE OF LAND USE ENTITLEMENTS IN FOUR DESIGNATED LOCATIONS ALONG THE SR-60 EAST CORRIDOR AREA

The City Council of the City of Moreno Valley does hereby ordain as follows:

SECTION 1. FINDINGS

The City Council of the City of Moreno Valley hereby finds, determines, and declares that:

A. On January 22, 2013, at a duly noticed public meeting, the City Council lawfully adopted an urgency ordinance (Ordinance No. 859) imposing a moratorium on land use entitlements in four designated locations along the SR-60 East Corridor Area (identified in Exhibit A) pending study of a potential amendment to the City's general plan and zoning designations.

B. Government Code § 65858(a) authorized the City Council to adopt Ordinance No. 859 as an urgency measure, effective immediately and without public hearing, to protect the public safety, health and welfare. The interim ordinance may prohibit any uses which may be in conflict with general plan, specific plan, or zoning proposals which the City is considering or studying or intends to study within a reasonable time. Government Code § 65858 provides that Ordinance No. 859 expires and is no further force and effect forty-five (45) days from its date of adoption, unless the City Council extends the urgency ordinance following notice and a public hearing.

C. Prior to the hearing on this Ordinance, the City Council issued a written report describing the measures and actions taken by the City to alleviate the circumstances and conditions that led to the adoption and extension of Ordinance No. 859, as required by Government Code § 65858(d).

D. On February 26, 2013, in accordance with Government Code § 65858, the City Council held a properly noticed public hearing to consider extending the moratorium for a period of ten (10) months and fifteen (15) days from the date that Ordinance No. 859 would have otherwise expired.

E. The City Council has determined that the circumstances and conditions that led to the adoption of Ordinance No. 859, which are set forth therein and summarized herein, have not been alleviated as of the date of this Ordinance and would continue to create the concerns described in Ordinance No. 859.

F. Within the four designated locations along the SR-60 East Corridor Area identified on Exhibit A, there are a wide variety of planned and existing land uses, including residential, commercial, retail, business park, and industrial uses. The approval of applications to develop currently vacant parcels within these designated areas could result in the development of potentially incompatible uses, and could frustrate the City's intent to pursue a comprehensive planning approach for the designated area.

G. An extension of the moratorium is necessary to protect the public health, safety and welfare of the City and its residents because the untimely development of potentially incompatible uses could diminish the quality of life for current or future residents, and could frustrate the City's efforts to comprehensively plan for the most economically viable use of the area. The City Council has determined that a comprehensive review of the City's General Plan and zoning designations in this area is necessary, and has directed that a study be done to recommend changes to the Zoning Code and/or General Plan policies to facilitate compatible and economically-viable land use and development within the designated areas along the SR-60 East Corridor.

H. In 2000, the City Council adopted an interim urgency ordinance (Ordinance No. 573) and extended the interim ordinance (Ordinance No. 576) under the authority of Government Code § 65858. Ordinances No. 573 as extended by Ordinance No. 576 imposed a moratorium on land use approvals in some locations covered by this interim Ordinance. As required by Government Code § 65858(f), the City Council finds that the moratorium adopted in 2000 was adopted to protect the public health, safety, and welfare from an event separate and distinct from the circumstances that give rise to the current Ordinance. The 2000 moratorium was specifically adopted in response to litigation that caused the City to rescind Specific Plan 217. The current Ordinance is adopted for the reasons identified in Sections A through H of this Ordinance, relating to compatibility of existing and planned land uses in the designated locations.

I. In order to prevent the frustration of the City's study of potential changes to the City's Zoning Code and other adopted policies and the implementation thereof, the public interest, health, safety and welfare require the extension of Ordinance No. 859. The absence of this Ordinance would create a serious threat to the orderly and effective implementation of any zoning amendments, general plan amendments, or specific plan amendments which may be adopted by the City as a result of the studies.

J. The City Council finds that this Ordinance is immediately required to preserve the status quo in the four designated areas during the period of time required to complete the studies and potential revisions to the general plan, specific plans, or zoning ordinance in order to protect public safety, health, and welfare of the City and its residents.

K. The City Council further finds, based on the findings stated herein, the anticipated State Route 60 East Corridor Area Study, public comment and evidence presented at the public hearing, that in accordance with Government Code § 65858(c):

1. The continued approval of the development of multifamily housing projects would have a specific, adverse, impact on the public health or safety. As used in this paragraph, a “specific, adverse impact” means a significant, quantifiable, direct, and unavoidable impact, based on objective, identified written public health or safety standards, policies, or conditions as they existed on the date the ordinance is adopted by the legislative body. The development of residential uses in close proximity to SR 60 and existing industrial and large-scale commercial uses would result in significant, quantifiable, direct, and unavoidable impacts to the health or safety of future residents. Such development would violate objective, written public health or safety standards set forth in the City’s General Plan by exposing future residents to the effects of incompatible land uses, including high levels of noise. Continued approval of multifamily housing projects in the moratorium area would violate the following General Plan policies:

- The General Plan Land Use Map, which was designed to locate residential land uses away from high noise levels;
- Goal 2.1 (“a pattern of land uses, which organizes future growth, minimizes conflicts between land uses, and which promotes the rational utilization of presently underdeveloped and undeveloped parcels”);
- Policy 2.2.17 (“discourage nonresidential uses on local residential streets that generate traffic, noise or other characteristics that would adversely affect nearby residents”);
- Policy 2.4.3 (“the commercial area located on the north side of State Route 60 at the intersection of Moreno Beach Drive shall provide for the establishment of commercial land uses that serve the daily needs of the surrounding residential neighborhood and the traveling public. It is not intended to serve the needs of the region for goods, services, entertainment or shall identify the particular uses and type of development permitted on each parcel, which could include office uses and compatible noncommercial uses.”);
- Policy 2.5.2 (“locate manufacturing and industrial uses to avoid adverse impacts on surrounding land uses”);
- Objective 6.3 (“provide noise compatible land use relationships by establishing noise standards utilized for design and siting purposes”); and

- Objective 6.5 (“minimize noise impacts from significant noise generators such as, but not limited to, motor vehicles, trains, aircraft, commercial, industrial, construction, and other activities”).

2. The interim ordinance is necessary to mitigate or avoid the specific, adverse impact identified pursuant to paragraph (1), above. The continued development of residential uses could result in a long-term conflict between new residential and existing industrial/commercial land uses. By temporarily halting new development, the City can effectively evaluate and implement changes to its General Plan or Zoning Code to avoid such conflicts.

3. There is no feasible alternative to satisfactorily mitigate or avoid the specific, adverse impact identified in paragraph (1) as well or better, with a less burdensome or restrictive effect, than the adoption of the proposed interim ordinance.

L. The City Council finds, determines, and declares that there is a current and immediate threat to the public health, safety or welfare of the City and its citizens and that the approval of entitlements for new development in the designated areas would result in that threat to public health, safety or welfare, thereby necessitating the extension of Ordinance No. 859. The facts constituting such an urgency are set forth in Sections A-K, inclusive, of this Ordinance and Ordinance No. 859.

M. The City Council further finds that this is a matter of City-wide importance and is not directed towards nor targeting any particular parcel of property or proposed use.

SECTION 2. URGENCY MEASURE

Pursuant to Government Code § 65858, it is hereby declared that this Ordinance is necessary as an emergency, urgency measure for preserving the public health, safety and welfare. Until the City’s Zoning Code can be thoroughly examined and changed, as determined necessary by the City Council, to eliminate the potential adverse impacts or conflicts that such uses may cause within the designated areas, no land use permit shall be granted. This includes the approval of subdivisions, zone changes, use permits, variances, building permits, or any other applicable entitlement for land use that would result in new development in the designated areas. This moratorium does not preclude the issuance of building permits that would establish uses that received any land use approval from the Planning Commission prior to the adoption of Ordinance No. 859, nor shall it prohibit the issuance of building permits for modifications to existing structures in the designated areas. The City Council specifically recognizes that there will be a moratorium on all land use entitlements for new development at the four locations identified on Exhibit A.

SECTION 3. EXPIRATION

This Ordinance shall extend the effective period of Ordinance No. 859 for a period of ten (10) months and fifteen (15) days from the date that Ordinance No. 859 would have otherwise expired, unless further extended by the City Council pursuant to the procedures set forth in Government Code § 65858.

SECTION 4. SEVERABILITY

If any section, subsection, sentence, clause, phrase or word of this Ordinance is for any reason held to be invalid by a court of competent jurisdiction, such decision shall not affect the validity of the remaining portions of this Ordinance. The City Council hereby declares that it would have passed and adopted this Ordinance, and each and all provisions hereof, irrespective of the fact that one or more provisions may be declared invalid.

SECTION 5. PUBLICATION

The City Clerk shall certify to the passage of this Ordinance and cause the same to be published in the manner prescribed by law.

SECTION 6. EFFECTIVE DATE

This Ordinance shall be introduced, passed and adopted at one and the same meeting and shall become effective immediately and shall extend the effective period of Ordinance No. 859 for a period of ten (10) months and fifteen (15) days from the date that Ordinance No. 859 would have otherwise expired. The reasons for this urgency are set forth in Paragraphs A-K, inclusive, and Section 1, of this Ordinance.

Passed, approved and adopted this 26th day of February, 2013.

Mayor

ATTEST:

City Clerk

APPROVED AS TO FORM:

City Attorney

URGENCY ORDINANCE JURAT

STATE OF CALIFORNIA)
COUNTY OF RIVERSIDE) ss.
CITY OF MORENO VALLEY)

I, Jane Halstead, City Clerk of the City of Moreno Valley, California, do hereby certify that urgency Ordinance No. 861 was read and duly and regularly adopted by the City Council of the City of Moreno Valley at a regular meeting thereof held on the 26th day of February, 2013 by the following vote:

AYES:

NOES:

ABSENT:

ABSTAIN:

(Council Members, Mayor Pro Tem and Mayor)

City Clerk

(SEAL)

SR-60 East Corridor Area

Item No. E.1

-269-

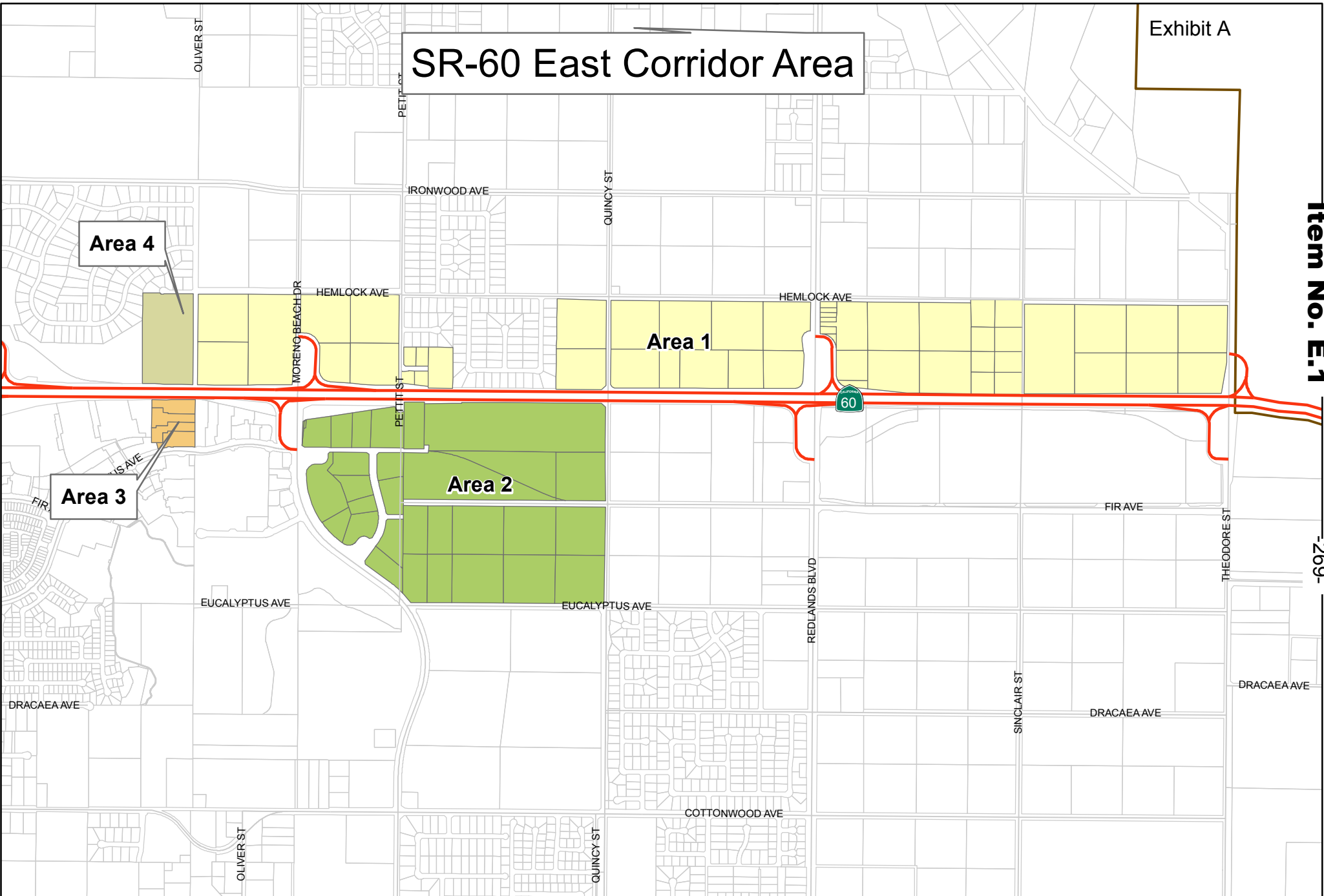

Area 4

Area 3

Area 1

Area 2



The information shown on this map was compiled from the Riverside County GIS and the City of Moreno Valley GIS. The land base and facility information on this map is for display purposes only and should not be relied upon without independent verification as to its accuracy. Riverside County and City of Moreno Valley will not be held responsible for any claims, losses or damages resulting from the use of this map.

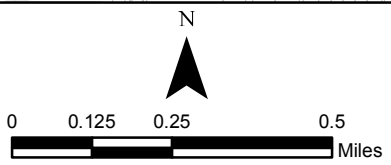

- Area1
- Area2
- Area3
- Area4
- Parcels
- City Boundary



This page intentionally left blank.

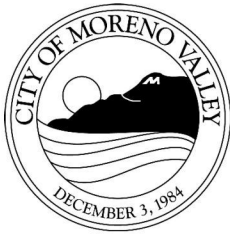

APPROVALS	
BUDGET OFFICER	
CITY ATTORNEY	<i>SMB</i>
CITY MANAGER	<i>MD</i>

Report to City Council

TO: Mayor and City Council

FROM: Michelle Dawson, Assistant City Manager

AGENDA DATE: February 26, 2013

TITLE: APPROVE RESOLUTION NO. 2013-15 ESTABLISHING THE MAYOR'S AD HOC COMMITTEE ON INCREASING GRADUATION RATES

RECOMMENDED ACTION

Recommendation: That the City Council:

1. Approve Resolution No. 2013-15 establishing a Mayor's Ad Hoc Committee on Increasing Graduation Rates. Resolution No. 2013-15 - A Resolution of the City Council of the City of Moreno Valley, California, Establishing A Mayor's Ad Hoc Committee on Increasing Graduation Rates

BACKGROUND

According to the California Department of Education, the high school graduation rate for Moreno Valley Unified School District's Class of 2010-11 was 69%*. This is lower than both the national and state averages (the graduation rate in California for 2010-11 was 76%).

DISCUSSION

Too many Moreno Valley high school students are leaving school without graduating. While the leadership of MVUSD is making every effort to remediate the various factors that contribute to low graduation rates, schools are just one part of what needs to be a community-wide effort.

At their workshop conducted on February 2, 2013, the City Council agreed to support a partnership among the City, Moreno Valley Unified School District (MVUSD) and the

*This statistic represents the cohort graduation rate which is the percentage of students who enter ninth grade together that then graduated within four years.

business community to make increasing our graduation rate a top priority. Mayor Owings is proposing the formation of a Mayor's Ad Hoc Committee on Increasing Graduation Rates. The goal of this committee will be to increase graduation rates through the implementation of a focused partnership among the City of Moreno Valley, the Moreno Valley Unified School District and the business community. It is necessary to focus efforts on students throughout their time in our school system, teaching them and their families the importance of good study habits while in elementary school, supporting programs such as AVID that increase schoolwide learning and performance, expanding the successful vocational training programs currently in place, and establishing partnerships within the community for job training and internship opportunities.

The Mayor's Ad Hoc Committee on Increasing Graduation Rates is proposed to identify talented, purposeful and generous community members with a desire to make a positive impact on our youth. The proposed resolution will establish the committee as a four-year ad hoc committee tasked with mentoring students and providing them with meaningful work and life skills that will translate to higher graduation rates. Ad Hoc Committees are temporary committees established by the City Council to achieve a purported goal. As proposed, the Ad Hoc Committee on Increasing Graduation Rates will terminate on June, 30, 2017 but may be extended by the City Council following a review of the Committee's achievements. Should the Mayor and City Council choose to extend the term of the Committee after June 30, 2017 it may consider establishing a standing commission or board through adoption of an ordinance.

Mayor Owings has approached MVUSD Superintendent Dr. Judy White and requested that she accept the role of Chairperson of the Mayor's Ad Hoc Committee on Increasing Graduation Rates. As proposed in the attached resolution, the Committee will consist of the Chairperson and at least four other members selected by the Mayor and Chairperson. Additional members may be appointed at the discretion of the Chair. The membership of the committee as proposed would deviate from other City-established boards and commissions in that residency in Moreno Valley would not be a requirement. The intent is to create partnerships with as many dedicated people and businesses as we can to achieve the goal of the committee, therefore limiting membership strictly to city residents would be too constricting. An application process will be used in accordance with standards established by City boards and commissions. One membership appointment may be reserved for a youth member at the discretion of the Chair. As stated in the resolution, the Committee will have the following powers and duties:

- a. Develop and implement programs and/or services that will further the goal of increasing graduation rates in Moreno Valley.
- b. Recruit students, businesses, and volunteers from the community to assist in this effort.
- c. Solicit funds from governmental agencies, private contributions, grants, sponsorships or participate in other fundraising opportunities.
- d. Submit periodic status reports to the Mayor and City Council.

Following discussion with the Mayor and in anticipation of the formation of the Mayor's Ad Hoc Committee on Increasing Graduation Rates, Superintendent White has already discussed with City staff a potential program to move toward the stated goal of the committee. The concept for this is a summer internship program linking the classrooms with the business community. The program would combine one week of specialized instruction on professional development followed by several weeks of on-the-job training through an internship. The student interns would be paid a small stipend at the end of the program. Mayor Owings has also met with Riverside County Superintendent of Schools Kenneth Young about the success of AVID programs in closing the achievement gap and the desire to expand these programs as well. While these are just two ideas, they are examples of the type of programs that the Mayor's Ad Hoc Committee on Increasing Graduation Rates would develop, support and/or implement.

ALTERNATIVES

1. Approve the proposed Resolution establishing a Mayor's Ad Hoc Committee on Increasing Graduation Rates. *Staff recommends this alternative as it promotes the City Council's stated desire to partner with the Moreno Valley Unified School District and the business community to focus efforts on increasing high school graduation rates.*
2. Do not approve the proposed Resolution establishing a Mayor's Ad Hoc Committee on Increasing Graduation Rates. *Staff does not recommend this alternative as it would not promote the City Council's stated desire to partner with the Moreno Valley Unified School District and the business community to focus efforts on increasing high school graduation rates.*

FISCAL IMPACT

There is no fiscal impact.

CITY COUNCIL GOALS

Positive Environment: Create a positive environment for the development of Moreno Valley's future.

ATTACHMENTS

- | | |
|---------------|---|
| Attachment 1: | Proposed Resolution |
| Attachment 2: | Cover for Application Form |
| Attachment 3: | Application Form: Mayor's Ad Hoc Committee on Increasing Graduation Rates |

Prepared By:
Michelle Dawson
Assistant City Manager

Council Action	
Approved as requested:	Referred to:
Approved as amended:	For:
Denied:	Continued until:
Other:	Hearing set for:

RESOLUTION NO. 2013-15

A RESOLUTION OF THE CITY COUNCIL OF THE CITY OF MORENO VALLEY, CALIFORNIA, ESTABLISHING A MAYOR'S AD HOC COMMITTEE ON INCREASING GRADUATION RATES

WHEREAS, earning a diploma is evidence of dedication, hard work and commitment; and

WHEREAS, high school graduates have an advantage in the job market and typically earn more money than students who did not complete their high school education; and

WHEREAS, the leadership at Moreno Valley Unified School District ("District") is dedicated to providing quality education to Moreno Valley's youth, making "Excellence on Purpose" a way of life; and

WHEREAS, schools are just one part of a larger social system that includes families and communities, which are equally responsible for the development of youth; and

WHEREAS, at their February 2, 2013 Workshop, the Mayor and City Council agreed that achieving a more respectable graduation rate and supporting a Mayor's Ad Hoc Committee on Increasing Graduation Rates are top priorities for the City; and

WHEREAS, the goal of a Mayor's Ad Hoc Committee on Increasing Graduation Rates is to increase graduation rates through the implementation of a focused partnership among the City of Moreno Valley, the Moreno Valley Unified School District and the business community; and

WHEREAS, objectives to be achieved in the attainment of that goal include 1) creating a strong, healthy and supportive community that addresses the preparation of youth for college and/or career success and 2) responding responsibly to the business community's request for a highly qualified workforce; and

WHEREAS, Section 9.0 of the City's Rules of Procedure for Council Meetings and Related Functions and Activities, as established in City of Moreno Valley Resolution No. 2011-117, states that the City Council may, by motion or resolution, appoint ad hoc committees for particular temporary purposes;

NOW, THEREFORE, THE CITY COUNCIL OF THE CITY OF MORENO VALLEY, CALIFORNIA, DOES HEREBY RESOLVE AS FOLLOWS:

1. There is created a Mayor's Ad Hoc Committee on Increasing Graduation be appointed by the Mayor and Chair after reviewing applications submitted to the City Clerk's office in accordance with the standards

Rates.

2. The Ad Hoc Committee shall consist of at least 5 members including a Committee Chair who shall be appointed by the Mayor. Additional members may be added at the discretion of the Chair. The remaining members shall be appointed by the Mayor and Chair after reviewing applications submitted to the City Clerk's office in accordance with the standards established by other City Commissions and Boards. The Chair shall select a Vice Chair from among the appointed committee members.
3. One or more members may be a youth representative, at the discretion of the Chair.
4. The Mayor's Ad Hoc Committee on Increasing Graduation Rates shall be an Ad Hoc Committee formed for the particular purpose of focusing City, School District and business community effort and resources on programs and/or services to increase the graduation rate at Moreno Valley high schools.
5. Ad Hoc Committees are temporary and, as such, by adopting this resolution the City Council agrees that this will be a temporary committee which will expire on June 30, 2017.
6. Terms for committee members will also expire on that date. Any vacancies created on the committee prior to June 30, 2017 will be filled through the appointment of the Mayor and Chair after reviewing applications submitted to the City Clerk's office in accordance with the standards established by other City Commissions and Boards.
7. Should the Mayor and City Council choose to extend the life of the Committee after June 30, 2017, it may consider establishing a standing commission or board through adoption of an ordinance.
8. Should the Mayor and City Council extend the Committee as a standing commission or board, the terms of the Committee Members shall be defined within an ordinance establishing the board or commission.
9. Residency in the City of Moreno Valley shall not be a requirement for Committee membership.
10. Members of other City of Moreno Valley boards or commissions will be considered for Committee membership.
11. Unless otherwise stated in this resolution, all relevant sections of Municipal Code 2.06 shall apply to this Committee. chairperson, with the consent of the committee, may fix and appoint the membership of such subcommittees. Membership on a subcommittee need not be limited to

2
Resolution No. 2013-15
Date Adopted: February 26, 2013

members of the committee except that the chairperson of the subcommittee shall be a member of the Ad Hoc Committee.

12. The Mayor's Ad Hoc Committee on Increasing Graduation Rates shall have the following power and duties:
 - a. Develop and implement programs and/or services that will further the goal of increasing graduation rates in Moreno Valley.
 - b. Recruit students, businesses, and volunteers from the community to assist in this effort.
 - c. Solicit funds from private contributions, grants, sponsorships or participate in other fundraising opportunities.
 - d. Submit periodic status reports to the Mayor and City Council.
13. The Ad Hoc Committee may establish such temporary subcommittees as it may deem expedient for the performance of its duties, and the chairperson, with the consent of the committee, may fix and appoint the membership of such subcommittees. Membership on a subcommittee need not be limited to members of the committee except that the chairperson of the subcommittee shall be a member of the Ad Hoc Committee.
14. The City Manager may appoint a secretary and/or other staff for the Ad Hoc Committee and provide such reimbursement for their necessary expenses as may be authorized by the City Council in the budget and approved in advance by the City Manager.
15. The Ad Hoc Committee shall hold one or more regular meetings per month and designate the times, dates, and places therefor. All meetings of the Ad Hoc Committee and any subcommittees shall be open to the public.
16. Special meetings may be called by the Chairperson or by a majority of the Ad Hoc Committee provided that notice of such special meetings is given to each member of the Committee at least 72 hours prior to the time of the meeting.
17. Three or more members of the committee shall constitute a quorum for the conduct of business.
18. The Ad Hoc Committee shall be governed by the Brown Act and follow the Rules of Procedure for Council Meetings and Related Functions and Activities as enacted by City Resolution 2013-10, and as amended by future City Resolutions.

3
Resolution No. 2013-15
Date Adopted: February 26, 2013

19. The Ad Hoc Committee shall adopt rules for the transaction of business and shall keep a public record of its action. Promptly after approval thereof by the committee, the original minutes of the committee meetings shall be filed with the City Clerk.
20. If a member of the Ad Hoc Committee is absent without cause from three successive regular meetings of the committee or from twenty-five percent (25%) of the duly scheduled meetings of the committee within any fiscal year, the committee may request the mayor and Chairperson declare a position vacant. An absence may be excused if it is due to illness or is unavoidable and the member gives notice to assigned City staff as to the reason.

APPROVED AND ADOPTED this 26th day of February, 2013.

Mayor of the City of Moreno Valley

ATTEST:

City Clerk

APPROVED AS TO FORM:

City Attorney

4
Resolution No. 2013-15
Date Adopted: February 26, 2013

RESOLUTION JURAT

STATE OF CALIFORNIA)
COUNTY OF RIVERSIDE) ss.
CITY OF MORENO VALLEY)

I, Jane Halstead, City Clerk of the City of Moreno Valley, California, do hereby certify that Resolution No. 2013-15 was duly and regularly adopted by the City Council of the City of Moreno Valley at a regular meeting thereof held on the 26th day of February, 2013 by the following vote:

AYES:

NOES:

ABSENT:

ABSTAIN:

(Council Members, Mayor Pro Tem and Mayor)

CITY CLERK

(SEAL)

5
Resolution No. 2013-15
Date Adopted: February 26, 2013

This page intentionally left blank.



THE CITY OF MORENO VALLEY MAYOR'S AD HOC COMMITTEE ON INCREASING GRADUATION RATES

*“Positive, Purposeful Work Toward Something
Greater Than Ourselves”
--Mayor Tom Owings*

About the Mayor’s Ad Hoc Committee on Increasing Graduation Rates

The goal of the Mayor’s Ad Hoc Committee on Increasing Graduation Rates is to increase graduation rates through the implementation of a focused partnership among the City of Moreno Valley, the Moreno Valley Unified School District and the business community.

The Mayor’s Ad Hoc Committee on Increasing Graduation Rates is an Ad Hoc Committee established by the City of Moreno Valley to identify talented, purposeful and generous community members with a desire to make a positive impact on our youth. Established by resolution as a Four-Year Ad Hoc Committee, the committee members are tasked with mentoring students and providing them with meaningful work and life skills that will translate to higher graduation rates. The Ad Hoc Committee will terminate on June, 30, 2017 and may be extended by the City Council following a review of the Committee’s achievements. Ad Hoc Committees are temporary committees established by the City Council to achieve a purported goal. Should the Mayor and City Council choose to extend the term of the Committee after June 30, 2017 it may consider establishing a standing commission or board through adoption of an ordinance.

Committee Membership

The Chairperson of the Committee shall be selected by the Mayor. Committee members are nominated by the Mayor or the Committee Chair. Membership will consist of at least 5 members including the Committee Chair appointed by the Mayor and a Vice Chair selected by the Chair. At the discretion of the Chair, one or members may be a youth representative also selected by the Mayor or the Committee Chair. Terms shall expire when the Ad Hoc Committee expires on June 30, 2017. Should the Mayor and City Council extend the Committee as a standing commission or board, the terms of the Committee Members shall be defined within an ordinance establishing the board or commission.

Meetings

The meeting locations and times shall be established by the Committee Chair.

City Staff Liaison for the Mayor’s Ad Hoc Committee on Increasing Graduation Rates:

Michele Patterson, Assistant to the City Manager

(951) 413-3030

michelep@moval.org

This page intentionally left blank.

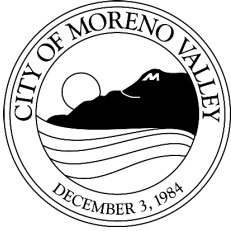

City of Moreno Valley

MAYOR'S AD HOC COMMITTEE ON INCREASING GRADUATION RATES Membership Application Form

For City Clerk's Use
Stamp Date and Time Received

The goal of the Mayor's Ad Hoc Committee on Increasing Graduation Rates is to increase graduation rates through the implementation of a focused partnership among the City of Moreno Valley, the Moreno Valley Unified School District and the business community. The Mayor's Ad Hoc Committee on Increasing Graduation Rates is an Ad Hoc Committee established by the City of Moreno Valley to identify talented, purposeful and generous community members with a desire to make a positive impact on our youth. Established by resolution as a Four-Year Ad Hoc Committee, the committee members are tasked with mentoring students and providing them with meaningful work and life skills that will translate to higher graduation rates.

Meeting Schedule: To Be Determined.

Name: _____

Home Address: _____

CONFIDENTIAL INFORMATION

Home Phone No.: _____ Driver's License No.: _____

Work Phone No.: _____ Cell Phone No.: _____

E-mail Address: _____

Business Name: _____ Title: _____

Address: _____

What other areas of interest do you have in our City government?

List any education, training, or special skills, you have which may be relevant or of particular use to this Board:

List any employment, volunteer work, or membership in a service/community organization that you have served on, or are now a member of. Please provide the name(s) of the agency(ies) and dates served:

Would you be available for meetings during the day or evening?

Why do you wish to serve on this Committee?

Explain briefly your understanding of what this Committee does, including its powers and limitations.

What do you hope to accomplish by your participation?

Have you ever been convicted of a felony? Yes No

If yes, please explain briefly: _____

I hereby give my consent that the City may obtain and review, on a confidential basis, such information regarding me as may be contained in the California State Summary Criminal History and in records of the California Department of Motor Vehicles. Yes No

I hereby agree to attend all Board meetings, unless excused, and understand I may be removed for lack of attendance, pursuant to Municipal Code, Subsection 2.06.010(C) which states, "If a member is absent without advance permission of the board or commission or the appointing authority, from three consecutive regular or from 25 percent of the duly scheduled meetings of the board or commission within any fiscal year, the membership shall thereupon become vacant and shall be filled as any other vacancy."

CERTIFICATE OF APPLICANT: I certify that all statements in this application are true and complete to the best of my knowledge. I understand that any false statements of material fact will subject me to disqualification or dismissal if appointed. I release the City of Moreno Valley from any liability for the use of aforesaid information.

Signature

Date

Please Note: Applications will be kept on file for potential future vacancies for one year after the application submittal date. Applications are accepted year-round.

Revised 08/03/09

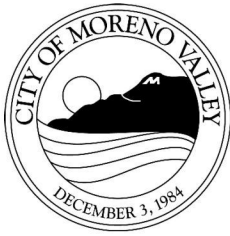

APPROVALS	
BUDGET OFFICER	<i>AS</i>
CITY ATTORNEY	<i>SMB</i>
CITY MANAGER	<i>MJO</i>

Report to City Council

TO: Mayor and City Council

FROM: Michelle Dawson, Assistant City Manager
Suzanne Bryant, Acting City Attorney

AGENDA DATE: February 26, 2013

TITLE: APPROVE RESOLUTION NO. 2013-16 ESTABLISHING A CHARTER EXPLORATORY AD HOC SUBCOMMITTEE

RECOMMENDED ACTIONS

Recommendations: That the City Council:

1. Approve Resolution No. 2013-16 establishing a Charter Exploratory Ad Hoc Subcommittee. Resolution No. 2013-16 - A Resolution of the City Council of the City of Moreno Valley, California, Establishing a Charter Exploratory Ad Hoc Subcommittee of the City Council
2. Appoint two members of the City Council to serve as the Ad Hoc Subcommittee tasked with drafting a city charter for the review of the full City Council and possible further action.

BACKGROUND

The City of Moreno Valley is a general law city. General law cities follow the laws set forth in the Government Code commencing with Section 34000 and have less autonomy than those that adopt their own charter. The California Constitution authorizes the adoption of a city charter and provides that the charter has the force and effect of state law. A charter can only be adopted, amended or repealed by a majority vote of a city's voters.

At a special meeting/workshop held on February 2, 2013, the City Council, City Staff, and members of the public discussed the differences between charter cities and general law cities as well as the merits of both forms of local government. The attached chart (Attachment 2) illustrates the different characteristics of general law v. charter cities. At

their workshop, the City Council discussed the possibility of forming a Council Subcommittee to draft a Charter. Mayor Owings and Council Member Stewart indicated that they would be willing to serve on the Subcommittee. At the workshop the City Council also reached consensus that they would like to see a draft charter include the following elements:

- Council election runoffs
- Council Member qualifications
- Term limits
- Keep zoning the same as in general law cities
- Set the rules for Council vacancies/terminations
- Determine quorum/voting requirements
- Keep legislative authority the same as in general law cities
- Review charter options with regard to finance and taxation
- Keep regulations regarding streets and sidewalks the same as in general law cities
- Public contracts: charter with competitive bid
- Outsourcing
- Prevailing wage addressed within the charter for cost savings purposes
- Open government/sunshine rules
- No change in relationship with employees

Other comments from the workshop regarding a charter included the desire to address the question of a directly-elected Mayor, the need for community review, and targeting 2014 for a possible ballot measure for the community to vote on a charter.

DISCUSSION

A charter is a unique document that, in many ways, acts like a constitution for the city adopting it. The primary advantage of a charter is that it allows greater authority for a city's governance than that provided by state law. A city may tailor its organization and elective offices, taking into account the unique local conditions and needs of the community.

A charter transfers the power to adopt legislation affecting municipal affairs from the state legislature to the city adopting it. A city operating under a charter can acquire full control over its municipal affairs. These affairs are unaffected by the general laws passed by the state legislature on the same subject matters. This, in effect, gives the voters more control over their local government and the municipal affairs of the city.

Activities that the courts have consistently classified as "municipal affairs" include the following:

- Municipal election matters;
- Procedures for initiative, referendum and recall;
- Procedures for adopting ordinances;
- Compensation of City Officers and Employees (however labor relations is not a municipal affair and charter cities are subject to the Meyers-Milias Brown Act);

- Term limits for Council Members;
- Land use and zoning decisions (with a few exceptions)

Activities that the courts have consistently classified as statewide concerns include the following:

- Traffic and vehicle regulation;
- Licensing of members of a trade or profession;
- Tort claims against a government entity;
- Open and public meetings;
- Exercise of the power of eminent domain.

While a city charter is not required to have any particular provisions in it, a city will often reserve for itself the greatest amount of power it can when it adopts a charter. To accomplish this goal, the charter must include a declaration that it is the intention of the city to avail itself of the full power provided by the state constitution to charter cities. However, the city is not required to extend the breadth of its charter any further than it wishes.

There are two ways to adopt a city charter. One way is for the governing body of the city, on its own motion, to draft the charter. The other way is to elect a charter commission that would then have the responsibility of debating the provisions and drafting the charter. In either case, the charter is not adopted by the city until it is ratified by a majority vote of the city's voters. Prior to approving the submission to the voters of a proposal to adopt a charter, the Council would need to hold at least two public hearings on the matter of the proposed charter. The Council cannot conduct a vote on whether to approve the submission to the voters until 21 days after the second public hearing. If the charter measure passes, it would not go into effect until it has been filed and accepted by the Secretary of State.

The proposed resolution would establish a charter exploratory ad hoc committee. Section 9.0 of the City's Rules of procedure for Council Meetings and Related Functions and Activities, as established in Resolution 2013-10, states that the City Council may, by motion or resolution, appoint ad hoc committees for particular temporary purposes. The City Attorney's Office will act as staff liaison in assisting the Charter Exploratory Subcommittee.

ALTERNATIVES

1. Approve proposed Resolution establishing a Charter Exploratory Ad Hoc Subcommittee and appoint two members of the City Council to serve as the Ad Hoc Subcommittee tasked with drafting a city charter for the review of the full City Council and possible further action. *Staff recommends this alternative.*
2. Do not approve the proposed Resolution establishing a Charter Exploratory Ad Hoc Subcommittee and not appoint two members of the City Council to serve as the Ad Hoc Subcommittee tasked with drafting a city charter for the review of the

full City Council and possible further action. *Staff does not recommend this alternative.*

FISCAL IMPACT

There is no fiscal impact in establishing a Charter Exploratory Ad Hoc Subcommittee.

ATTACHMENTS

- Attachment 1: Proposed Resolution
- Attachment 2: Charter City v. General Law Chart

Prepared By:
Michelle Dawson
Assistant City Manager

Concurred By:
Suzanne Bryant
Acting City Attorney

Council Action	
Approved as requested:	Referred to:
Approved as amended:	For:
Denied:	Continued until:
Other:	Hearing set for:

RESOLUTION NO. 2013-16

A RESOLUTION OF THE CITY COUNCIL OF THE CITY OF MORENO VALLEY, CALIFORNIA, ESTABLISHING A CHARTER EXPLORATORY AD HOC SUBCOMMITTEE OF THE CITY COUNCIL

WHEREAS, the City Council has considered and discussed the Charter City v. General Law forms of government; and

WHEREAS, at their February 2, 2013 Special Meeting/Workshop the City Council discussed the possibility of forming an Ad Hoc Subcommittee to draft a charter for the consideration of the full City Council and residents.

NOW, THEREFORE, THE CITY COUNCIL OF THE CITY OF MORENO VALLEY, CALIFORNIA, DOES HEREBY RESOLVE THAT A CHARTER EXPLORATORY AD HOC SUBCOMMITTEE IS ESTABLISHED WITH THE FOLLOWING SCOPE AND CHARACTERISTICS:

Section 1. Specific tasks and objectives shall include:

1. Research and enumerate the advantages and disadvantages of the Charter City v. General Law forms of government;
2. Propose charter language;
3. Solicit citizen input;
4. Present a draft charter to the City Council;
5. Make recommendations to the City Council regarding a ballot measure to enact a City Charter.

Section 2. Committee type and composition.

1. The committee shall be a temporary Ad Hoc Subcommittee.
2. The Subcommittee shall consist of two members of the City Council as selected by motion of the City Council.
3. The Subcommittee shall terminate when its tasks and objectives have been completed.

Section 3. Support to the Subcommittee.

Staff support shall be provided to the Subcommittee by the City Attorney's Office.

1
Resolution No. 2013-16
Date Adopted: February 26, 2013

Section 4. Meetings.

The Subcommittee shall meet on a date and time selected by the members of the Subcommittee. The meetings shall be noticed pursuant to the Brown Act.

Section 5. Reporting.

Minutes of the Subcommittee shall be prepared by staff designated by the City Attorney's Office and shall be a public record, filed with the City Clerk.

APPROVED AND ADOPTED this 26th day of February, 2013.

Mayor of the City of Moreno Valley

ATTEST:

City Clerk

APPROVED AS TO FORM:

City Attorney

Resolution No. 2013-16²
Date Adopted: February 26, 2013

RESOLUTION JURAT

STATE OF CALIFORNIA)
COUNTY OF RIVERSIDE) ss.
CITY OF MORENO VALLEY)

I, Jane Halstead, City Clerk of the City of Moreno Valley, California, do hereby certify that Resolution No. 2013-16 was duly and regularly adopted by the City Council of the City of Moreno Valley at a regular meeting thereof held on the 26th day of February, 2013 by the following vote:

AYES:

NOES:

ABSENT:

ABSTAIN:

(Council Members, Mayor Pro Tem and Mayor)

CITY CLERK

(SEAL)

3
Resolution No. 2013-16
Date Adopted: February 26, 2013

This page intentionally left blank.

What is the Constitutional Framework for Charter Cities?

Article XI, section 3(a) of the California Constitution authorizes the adoption of a city charter and provides that a charter has the force and effect of state law.

Article XI, section 5(a), the "home rule" provision, affirmatively grants to charter cities supremacy over "municipal affairs." However, the California Constitution does not define the term "municipal affair."

What is a Charter?

A city charter is a unique document that, in many ways, acts like a constitution for the city adopting it. It can only be adopted, amended or repealed by a majority vote of a city's voters. The primary advantage of a charter is that it allows greater authority for a city's governance than that provided by state law. A city may tailor its organization and elective offices, taking into account the unique local conditions and needs of the community.

A charter transfers the power to adopt legislation affecting municipal affairs from the state legislature to the city adopting it. A city operating under a charter can acquire full control over its municipal affairs. These affairs are unaffected by the general laws passed by the state legislature on the same subject matters. This, in effect, gives the local voters more control over their local government and the affairs of the city. However, a city operating under a charter is still subject to the general laws, as passed by the state legislature, on affairs that are not municipal in nature, and are of statewide concern (e.g., California Vehicle Code).

What are "Municipal Affairs?"

It is the scope of the term "municipal affairs" that provides the opportunity for uncertainty. No easy analytical test exists. The threshold issue is whether there is a conflict between state law and a charter city enactment. The next issue is whether the state regulation addressed an issue of "state wide concern." Courts analyze these conflicts on a case-by-case basis.

What Activities Have the Courts Classified As Municipal Affairs?

There are some areas that the courts have consistently classified as municipal affairs. Examples include the following:

- Municipal Election Matters;
- Procedures for Initiative, Referendum and Recall;

- Procedures for Adopting Ordinances;
- Compensation of City Officers and Employees (labor relations is not a municipal affair; charter cities are subject to the Meyers-Milias Brown Act. Cal. Gov't Code § 3500);
- Term Limits for Council Members. *See Cawdrey v. City of Redondo Beach*, 15 Cal. App. 4th 1212 (1993); *but see* Cal. Gov't Code § 36502(b) (regulating term limits);
- Land Use and Zoning Decisions (with a few exceptions).

What Activities Have the Courts Classified as Statewide Concerns?

The following have consistently been classified by the courts as matters of statewide concern:

- Traffic and Vehicle Regulation;
- Licensing of Members of a Trade or Profession;
- Tort Claims against a Governmental Entity;
- Open and Public Meetings;
- Exercise of the Power of Eminent Domain.

What is in a Charter?

While a city charter is not required to have any particular provisions in it, a city will often reserve for itself the greatest amount of power it can when it adopts a charter. To accomplish this goal, the charter must include a declaration that it is the intention of the city to avail itself of the full power provided by the state constitution to charter cities. However, the city is not required to extend the breadth of its charter any further than it wishes.

Some of the common areas that are explicitly regulated in a charter are:

- The date and conduct of city elections;
- Form of government;
- Sub-government procedures in all or part of the city.

What is the (General) Procedure to Adopt a Charter?

There are two ways to adopt a charter. One way is to elect a charter commission. The commission then has the responsibility of debating over the provisions and the drafting of the charter. The other alternative allows the governing board of the city, on its own motion, to draft the charter. In either case, the charter is not

adopted by the city until it is ratified by a majority vote of the city's voters. Prior to approving the submission to the voters of a proposal to adopt a charter, the Council would have to hold at least two public hearings on the matter of the proposed charter. Notice of the public hearings shall be given by publication in a newspaper at least 21 calendar days prior to the date of each public hearing. The second hearing shall be held at least 30 days after the first public hearing. The Council shall not conduct a vote on whether to approve the submission to the voters of the proposal to adopt a charter until 21 days after the second public hearing.

If the Charter measure passes, it would not go into effect until it has been filed and accepted by the Secretary of State. If there were a change in the form of government included in the Charter, the Charter provisions about those topics would control.

General Law City v. Charter City

Characteristic	General Law City	Charter City
Ability to Govern Municipal Affairs	Bound by the state's general law, regardless of whether the subject concerns a municipal affair.	Has supreme authority over "municipal affairs." Cal. Const. art. XI, § 5(b).
Form of Government	State law describes the city's form of government For example, Government Code section 36501 authorizes general law cities be governed by a city council of five members, a city clerk, a city treasurer, a police chief, a fire chief and any subordinate officers or employees as required by law.	Charter can provide for any form of government including the "strong mayor," and "city manager" forms. See Cal. Const. art. XI, § 5(b); Cal. Gov't Code § 34450 <i>et seq.</i>
Elections Generally	Municipal elections conducted in accordance with the California Elections Code. Cal. Elec. Code §§ 10101 <i>et seq.</i>	Not bound by the California Elections Code. May establish own election dates, rules, and procedures. See Cal. Const. art. XI, § 5(b); Cal. Elec. Code §§ 10101 <i>et seq.</i>
Methods of Elections	Generally holds at-large elections whereby voters vote for any candidate on the ballot. Cities may also choose to elect the city council "by" or "from" districts, so long as the election system has been established by ordinance and approved by the voters. Cal. Gov't Code § 34871. Mayor may be elected by the city council or by vote of the people. Cal. Gov't Code §§ 34902.	May establish procedures for selecting officers. May hold at-large or district elections. See Cal. Const. art. XI, § 5(b).
City Council Member Qualifications	<p>Minimum qualifications are:</p> <ol style="list-style-type: none"> 1. United States citizen 2. At least 18 years old 3. Registered voter 4. Resident of the city at least 15 days prior to the election and throughout his or her term 5. If elected by or from a district, be a resident of the geographical area comprising the district from which he or she is elected. <p>Cal. Elec. Code § 321; Cal. Gov't Code §§ 34882, 36502; 87 Cal. Op. Att'y Gen. 30 (2004).</p>	Can establish own criteria for city office provided it does not violate the U.S. Constitution. Cal. Const. art. XI, § 5(b), 82 Cal. Op. Att'y Gen. 6, 8 (1999).

Characteristic	General Law City	Charter City
Public Funds for Candidate in Municipal Elections	No public officer shall expend and no candidate shall accept public money for the purpose of seeking elected office. Cal. Gov't Code § 85300.	Public financing of election campaigns is lawful. <i>Johnson v. Bradley</i> , 4 Cal. 4th 389 (1992).
Term Limits	May provide for term limits. Cal. Gov't Code § 36502(b).	May provide for term limits. Cal. Const. art. XI, § 5(b); Cal Gov't Code Section 36502 (b).
Vacancies and Termination of Office	An office becomes vacant in several instances including death, resignation, removal for failure to perform official duties, electorate irregularities, absence from meetings without permission, and upon non-residency. Cal. Gov't Code §§ 1770, 36502, 36513.	May establish criteria for vacating and terminating city offices so long as it does not violate the state and federal constitutions. Cal. Const. art. XI, § 5(b).
Council Member Compensation and Expense Reimbursement	Salary-ceiling is set by city population and salary increases set by state law except for compensation established by city electors. See Cal. Gov't Code § 36516.	May establish council members' salaries. See Cal. Const. art. XI, § 5(b).
Legislative Authority	Ordinances may not be passed within five days of introduction unless they are urgency ordinances. Cal. Gov't Code § 36934. Ordinances may only be passed at a regular meeting, and must be read in full at time of introduction and passage except when, after reading the title, further reading is waived. Cal. Gov't Code § 36934.	May establish procedures for enacting local ordinances. <i>Brougher v. Bd. of Public Works</i> , 205 Cal. 426 (1928).
Resolutions	May establish rules regarding the procedures for adopting, amending or repealing resolutions.	May establish procedures for adopting, amending or repealing resolutions. <i>Brougher v. Bd. of Public Works</i> , 205 Cal. 426 (1928).
Quorum and Voting Requirements	A majority of the city council constitutes a quorum for transaction of business. Cal. Gov't Code § 36810. All ordinances, resolutions, and orders for the payment of money require a recorded majority vote of the total membership of the city council. Cal. Gov't Code § 36936. Specific legislation requires supermajority votes for certain actions.	May establish own procedures and quorum requirements. However, certain legislation requiring supermajority votes is applicable to charter cities. For example, see California Code of Civil Procedure section 1245.240 requiring a vote of two-thirds of all the members of the governing body unless a greater vote is required by charter.

Characteristic	General Law City	Charter City
Rules Governing Procedure and Decorum	Ralph Brown Act is applicable. Cal. Gov't Code §§ 54951, 54953(a). Conflict of interest laws are applicable. See Cal. Gov't Code § 87300 <i>et seq.</i> .	Ralph Brown Act is applicable. Cal. Gov't Code §§ 54951, 54953(a). Conflict of interest laws are applicable. See Cal. Gov't Code § 87300 <i>et seq.</i> . May provide provisions related to ethics, conflicts, campaign financing and incompatibility of office.
Personnel Matters	May establish standards, requirements and procedures for hiring personnel consistent with Government Code requirements. May have "civil service" system, which includes comprehensive procedures for recruitment, hiring, testing and promotion. See Cal. Gov't Code § 45000 <i>et seq.</i> Meyers-Milias-Brown Act applies. Cal. Gov't Code § 3500.	May establish standards, requirements, and procedures, including compensation, terms and conditions of employment for personnel. See Cal. Const. art. XI, § 5(b). Procedures set forth in Meyers-Milias-Brown Act (Cal. Gov't Code § 3500) apply, but note, "[T]here is a clear distinction between the <i>substance</i> of a public employee labor issue and the <i>procedure</i> by which it is resolved. Thus there is no question that 'salaries of local employees of a charter city constitute municipal affairs and are not subject to general laws.'" <i>Voters for Responsible Retirement v. Board of Supervisors</i> , 8 Cal.4th 765, 781 (1994).

Characteristic	General Law City	Charter City
Public Contracts	<p>Competitive bidding required for public works contracts over \$5,000. Cal. Pub. Cont. Code § 20162. Such contracts must be awarded to the lowest responsible bidder. Pub. Cont. Code § 20162. If city elects subject itself to uniform construction accounting procedures, less formal procedures may be available for contracts less than \$100,000. See Cal. Pub. Cont. Code §§ 22000, 22032.</p> <p>Contracts for professional services such as private architectural, landscape architectural, engineering, environmental, land surveying, or construction management firms need not be competitively bid, but must be awarded on basis of demonstrated competence and professional qualifications necessary for the satisfactory performance of services. Cal. Gov't Code § 4526.</p>	<p>Not required to comply with bidding statutes provided the city charter or a city ordinance exempts the city from such statutes, and the subject matter of the bid constitutes a municipal affair. Pub. Cont. Code § 1100.7; see <i>R & A Vending Services, Inc. v. City of Los Angeles</i>, 172 Cal. App. 3d 1188 (1985); <i>Howard Contracting, Inc. v. G.A. MacDonald Constr. Co.</i>, 71 Cal. App. 4th 38 (1998).</p>
Payment of Prevailing Wages	<p>In general, prevailing wages must be paid on public works projects over \$1,000. Cal. Lab. Code § 1771.</p>	<p>Historically, charter cities have not been bound by state law prevailing-wage requirements so long as the project is a municipal affair, and not one funded by state or federal grants. The California Supreme Court decided that Vista, a charter city, could avoid paying prevailing wages on public works projects not built with state or federal monies.</p>

Characteristic	General Law City	Charter City
Finance and Taxing Power	<p>May impose the same kinds of taxes and assessment as charter cities. See Cal. Gov't Code § 37100.5.</p> <p>Imposition of taxes and assessments subject to Proposition 218. Cal. Const. art.XIIIC.</p>	<p>Have the power to tax.</p> <p>Imposition of taxes and assessments subject to Proposition 218, Cal. Const. art. XIIIC, § 2, and own charter limitations.</p> <p>May proceed under a general assessment law, or enact local assessment laws and then elect to proceed under the local law.</p> <p><i>See J.W. Jones Companies v. City of San Diego</i>, 157 Cal. App. 3d 745 (1984).</p> <p>May impose real property transfer tax; does not violate either Cal. Const art. XIII A or California Government Code section 53725.</p> <p><i>See Cohn v. City of Oakland</i>, 223 Cal. App. 3d 261 (1990); <i>Fielder v. City of Los Angeles</i>, 14 Cal. App. 4th 137 (1993).</p>
Streets & Sidewalks	<p>State has preempted entire field of traffic control. Cal. Veh. Code § 21.</p>	<p>State has preempted entire field of traffic control. Cal. Veh. Code § 21.</p>

Characteristic	General Law City	Charter City
Public Utilities/Franchises	<p>May establish, purchase, and operate public works to furnish its inhabitants with electric power. See Cal. Const. art. XI, § 9(a); Cal. Gov't Code § 39732; Cal. Pub. Util. Code § 10002.</p> <p>May grant franchises to persons or corporations seeking to furnish light, water, power, heat, transportation or communication services in the city to allow use of city streets for such purposes. The grant of franchises can be done through a bidding process, under the Broughton Act, Cal. Pub. Util. Code §§ 6001-6092, or without a bidding process under the Franchise Act of 1937, Cal. Pub. Util. Code §§ 6201-6302.</p>	<p>May establish, purchase, and operate public works to furnish its inhabitants with electric power. See Cal. Const. art. XI, § 9(a); <i>Cal. Apartment Ass'n v. City of Stockton</i>, 80 Cal. App. 4th 699 (2000).</p> <p>May establish conditions and regulations on the granting of franchises to use city streets to persons or corporations seeking to furnish light, water, power, heat, transportation or communication services in the city.</p> <p>Franchise Act of 1937 is not applicable if charter provides. Cal. Pub. Util. Code § 6205.</p>
Zoning	<p>Zoning ordinances must be consistent with general plan. Cal. Gov't Code § 65860.</p>	<p>Zoning ordinances are not required to be consistent with general plan unless the city has adopted a consistency requirement by charter or ordinance. Cal. Gov't. Code § 65803.</p>

Thanks to the California League of Cities for providing information.

This page intentionally left blank.



MORENO VALLEY
WHERE DREAMS SOAR

Parks and Community Services

Item No. G.3.1

-303-

City Council Meeting: February 26, 2013

The Moreno Valley Parks and Community Services Department enriches lives and fosters harmony within the community through city-wide programs.

We believe quality of life improves through healthy lifestyles, and educational and recreational opportunities.

Mission Statement

In partnership with our citizens, the Department of Parks and Community Services provides comprehensive park, recreation, and programs, facilities, and services, which constantly respond to changing community needs. We strive to preserve, enhance, and protect our open space to enrich the quality of life for present and future generations in a safe and secure environment.

Quality of Life Statement

The definition of quality of life is different for everyone. The main thing that determines quality of life is our ability to enjoy all that life has to offer. For instance, the ability to walk, talk, see, and feel all contributes to our overall quality of life. A quality of life is a life full of meaning and purpose.



MORENO VALLEY
WHERE DREAMS SOAR

Recreation Programs

Item No. G.3.1

-307-



MORENO VALLEY
WHERE DREAMS SOAR

Time for Tots



Contract Classes





MORENO VALLEY
WHERE DREAMS SOAR

Spring Programs







MORENO VALLEY
WHERE DREAMS SOAR

Winter Programs



Senior Center Programs



Senior Community Center Programs





MORENO VALLEY
WHERE DREAMS SOAR

Child Care Programs

Item No. G.3.1

-315-

THINK Together and “A Child’s Place” Programs



After School Programs





MORENO VALLEY
WHERE DREAMS SOAR

Sports

Pee Wee and Junior Sports





Community Park Soccer Fields



Item No. G.3.1

-321-

Soccer Arena





MORENO VALLEY
WHERE DREAMS SOAR

Banquet Rooms

Item No. G.3.1

-323-



MORENO VALLEY
WHERE DREAMS SOAR

Conference and Recreation Center



324-

ite



Grand Valley Ballroom



Item No. G.3.1

-325-



-326-

ite





-328-



Item No. G.3.1

329-





Item No. G.3.1

-331-



MORENO VALLEY
WHERE DREAMS SOAR

Parks and Facilities





Hound Town Dog Park







Item No. G.3.1

-337-



MORENO VALLEY
WHERE DREAMS SOAR

Hike to the Top





MORENO VALLEY
WHERE DREAMS SOAR

Cottonwood Golf Center



Item No. G.3.1

-339-



TownGate Memorial Park Playground



Celebration Park



Shadow Mountain Park





MORENO VALLEY
WHERE DREAMS SOAR

Special Events

Artober Fest



Item No. G.3.1

345-

Pet in the Park



Youth Fest





MORENO VALLEY
WHERE DREAMS SOAR

Art and Wine Festival





MORENO VALLEY
WHERE DREAMS SOAR

July 4th

Family Fun Fest

Item No. G.3.1

-349-

Parade





Item No. G.3.1

-351-



MORENO VALLEY
WHERE DREAMS SOAR

Festival



-352-

ite



Item No. G.3.1

-353-





Item No. G.3.1

355-





MORENO VALLEY
WHERE DREAMS SOAR



SOARING Recreation Guide

Item No. G.3.1

-357-



MORENO VALLEY
WHERE DREAMS SOAR

Future Facilities and Upcoming Events

Movies in the Park

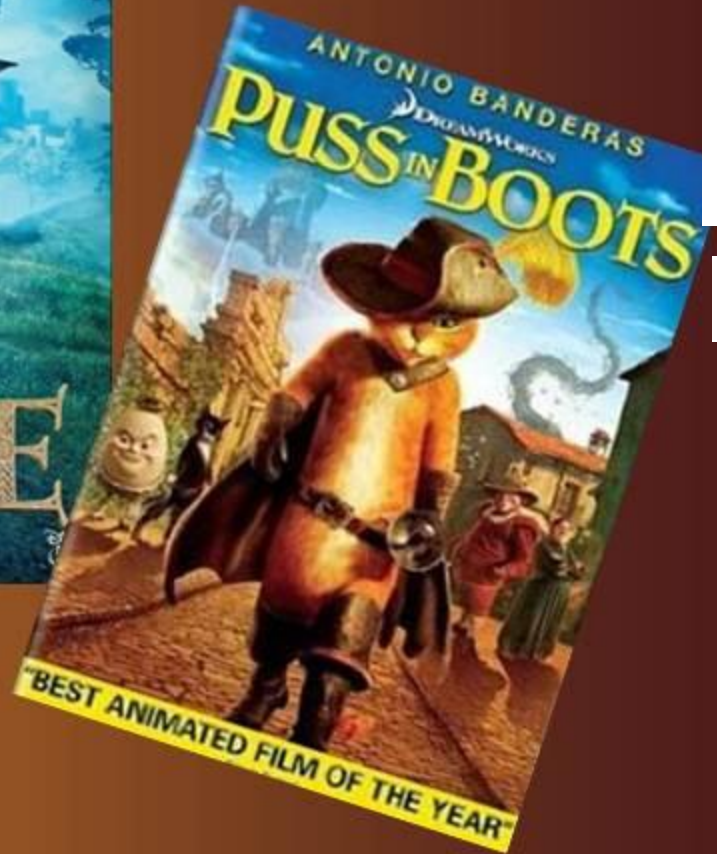
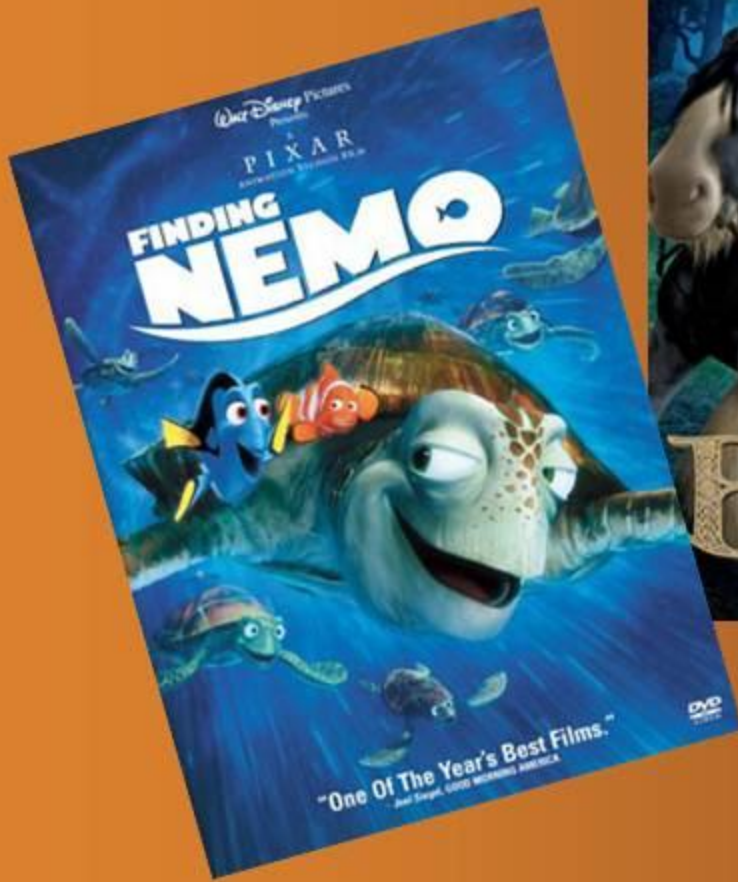



**Concerts
in
the
Park**



FREE MOVAL CONCERT SERIES

Fridays at 6:00 p.m. at Towngate Community Center, 13051 Elsworth Street. Bring your blankets and lawn chairs and prepare to party as we pay tribute to a variety of music.

Free Admission

May 3 **Red Not Chili Peppers**
Red Hot Chili Peppers Tribute Band/Rock

May 10 **Latin Society**
Latin Music

June 7 **Hulabaloo**
Children's

May 17 **Southband**
Classic Rock

June 14 **Joshua Tree**
U2 Tribute Band

May 31 **Gold Rush**
Country

June 21 **Soulsomatik**
Motown



Concert series concludes at July 4th Celebration Family Funfest located at Mountain View Middle School:
4:00 p.m. - Mrs. Jones Revenge
5:45 p.m. - Ghosts in the Machine
7:30 p.m. - Hollywood Stones



Item No. G.3.1
-361-

Conference and Recreation Center

Mural



-362-

ite



Item No. G.3.1

-363-





MORENO VALLEY
WHERE DREAMS SOAR

Lasselle Sports Park



Item No. G.3.1

-365-

Other Upcoming Events

Mud Run

**Wine and Art
Festival**

5K Walk

Oktober Fest

Bike Ride



This page intentionally left blank.

ORDINANCE NO. 860

AN ORDINANCE OF THE CITY COUNCIL OF THE CITY OF MORENO VALLEY, CALIFORNIA, AMENDING TITLE 2 OF THE CITY OF MORENO VALLEY MUNICIPAL CODE, BY ADDING A NEW CHAPTER 2.64, CREATING A JULY 4TH ADVISORY BOARD

The City Council of the City of Moreno Valley does ordain as follows:

SECTION 1. MUNICIPAL CODE AMENDED:

1.1 All prior enactments of the City, which are in conflict with this ordinance are hereby repealed, effective upon the date on which this ordinance becomes effective and operative.

SECTION 2. MUNICIPAL CODE AMENDED:

2.1 The list of chapters prefacing Title 2 of the City of Moreno Valley Municipal Code is hereby amended by adding thereto "Chapter 2.64."

2.2 Title 2 of the City of Moreno Valley Municipal Code is hereby further amended by adding thereto a new Chapter 2.64 reading as follows:

"Chapter 2.64

July 4th Advisory Board

Sections:

- 2.26.010 Created
- 2.26.020 Composition
- 2.26.030 Function, powers and duties
- 2.26.040 Chair, committees and staff
- 2.26.050 Meetings and rules of procedure

2.64.010 Created.

There is created a July 4th Advisory Board for the city. It shall consist of seven adult and two teen members, serving without compensation, and appointed in the manner and for the terms prescribed in Sections 2.04.060 and 2.06.010, respectively, of

1
Ordinance No. 860
Date Adopted: February 26, 2013

this code, except that the terms of the members first appointed to the board shall be set by lot, in such manner that three adult terms shall expire on July 31 of the first year, two adult terms shall expire on July 31 of the second year, and two adult terms shall expire on July 31 of the third year, and that the terms of the teen members shall expire on July 31 of the third year following appointment or until high school graduation, whichever comes first. Thereafter, all terms shall be for three years and shall expire three years after the effective date of the appointment; provided, however, that the term of an appointment made to fill an unexpired term shall be for the unexpired balance of such term.

2.64.020 Composition.

A. Insofar as practicable, the board shall be composed of nine public members, seven adults and two teens. In the event that an insufficient number of persons is available for appointment to the board, the City Council may make such substitute appointments as it deems necessary.

B. The board members should represent a cross section of the city's diversity, with substantial expertise in the fundraising and promotion of the July 4th Festivities.

2.64.030 Function, powers and duties.

A. The board shall act in an advisory capacity to the City Council to promote and seek possible funding sources for the City's July 4th Festivities including:

1. Solicit private contributions;
2. Solicit grants;
3. Solicit corporate sponsorships;
4. Facilitate fundraising opportunities;
5. Support the City's July 4th Festivities by volunteering the day of the event;
6. Make recommendations to enhance the parade;
7. Make recommendations to the fireworks' display;
8. Solicit vendors for the afternoon festivities;
9. Provide assistance to market and promote the July 4th event;
10. Provide ideas to generate additional revenue and increase attendance to the event;
11. Encourage participation from service organizations, school districts, businesses, and other governmental agencies;
12. Promote the importance of the July 4th Festivities to the city's quality of life;
13. Serve as an advisory group on the July 4th Festivities to the staff and City Council; and

14. Perform any other functions that may be designated by resolution or motion of the City Council.

2.64.40 Chair, committees and staff.

Designation of a chairperson and vice chairperson for the board shall be governed by Section 2.06.020 of this code. The board may establish such standing and temporary subcommittees as it may deem expedient for the performance of its duties and the chairperson, with the consent of the board, may fix and appoint the membership of such subcommittees. Except that the chairperson of each such subcommittee shall be a member of the board, membership on a subcommittee need not be limited to members of the board. The City Manager may appoint a secretary and other staff for the board and provide such reimbursement for their necessary expenses as may be authorized by the City Council in the city budget and approved in advance by the City Manager.

2.64.050 Meetings and rules of procedure.

A. The board shall hold regular meetings and designate the times, dates, and places therefor. All meetings of the board and each of its subcommittees shall be open to the public. Special meetings may be called by the chairperson or by a majority of the board, provided that notice of such special meetings is given to each member of the board at least forty-eight (48) hours prior to the time of the meeting. Five or more voting members of the board shall constitute a quorum for the conduct of business, and the affirmative votes of a majority of such quorum shall be necessary for the conduct of business. The board shall adopt rules for the transaction of its business. The board shall keep a public record of its actions. Promptly after approval thereof by the board, the original minutes of board meetings shall be filed with the Parks and Community Services Department.

B. If a member of the board is absent without cause from three successive regular meetings of the board, the board may request the City Council declare the position vacant. An absence may be excused if it is due to illness or is unavoidable, and the member gives notice to assigned city staff as to the reason.”

SECTION 3: EFFECT OF ENACTMENT:

3.1 Except as specifically provided herein, nothing contained in this ordinance shall be deemed to modify or supersede any enactment of the City Council which addresses the same subject addressed herein.

SECTION 4: NOTICE OF ADOPTION:

4.1 Within fifteen days after the adoption hereof, the City Clerk shall certify to the adoption of this ordinance and cause it to be posted in three public places within the city.

SECTION 5: EFFECTIVE DATE:

5.1 This ordinance shall take effect thirty days after the date of its adoption.

APPROVED AND ADOPTED this 26th day of February, 2013.

Mayor

ATTEST:

City Clerk

APPROVED AS TO FORM:

City Attorney

Ordinance No. _____ 4
Date Adopted: February 26, 2013

ORDINANCE JURAT

STATE OF CALIFORNIA)
COUNTY OF RIVERSIDE) ss.
CITY OF MORENO VALLEY)

I, Jane Halstead, City Clerk of the City of Moreno Valley, California, do hereby certify that Ordinance No. _____ had its first reading on February 12, 2013 and had its second reading on February 26, 2013, and was duly and regularly adopted by the City Council of the City of Moreno Valley at a regular meeting thereof held on the 26th day of February, 2013, by the following vote:

AYES:

NOES:

ABSENT:

ABSTAIN:

(Council Members, Mayor Pro Tem and Mayor)

CITY CLERK

(SEAL)

Ordinance No. _____ 5
Date Adopted: February 26, 2013

This page intentionally left blank.