

AGENDA

**CITY COUNCIL OF THE CITY OF MORENO VALLEY
MORENO VALLEY COMMUNITY SERVICES DISTRICT
CITY AS SUCCESSOR AGENCY FOR THE
COMMUNITY REDEVELOPMENT AGENCY OF
THE CITY OF MORENO VALLEY
MORENO VALLEY HOUSING AUTHORITY
BOARD OF LIBRARY TRUSTEES**

August 27, 2013

**SPECIAL PRESENTATIONS – 5:30 P.M.
REGULAR MEETING – 6:00 P.M.**

City Council Study Sessions

First & Third Tuesdays of each month – 6:00 p.m.

City Council Meetings

Second & Fourth Tuesdays of each month – 6:00 p.m.

City Council Closed Sessions

*Immediately following Regular City Council Meetings and
Study Sessions, unless no Closed Session Items are Scheduled*

City Hall Council Chamber - 14177 Frederick Street

Upon request, this agenda will be made available in appropriate alternative formats to persons with disabilities, in compliance with the Americans with Disabilities Act of 1990. Any person with a disability who requires a modification or accommodation in order to participate in a meeting should direct such request to Mel Alonzo, ADA Coordinator, at 951.413.3705 at least 48 hours before the meeting. The 48-hour notification will enable the City to make reasonable arrangements to ensure accessibility to this meeting.

Tom Owings, Mayor

_____, Mayor Pro Tem
Jesse L. Molina, Council Member

Richard A. Stewart, Council Member
Victoria Baca, Council Member

AGENDA
CITY COUNCIL OF THE CITY OF MORENO VALLEY
August 27, 2013

CALL TO ORDER – 5:30 PM

SPECIAL PRESENTATIONS

1. Recognition of 2013 Summer Reading Program Super Readers, by Moreno Valley Friends of the Library
2. Proclamation Recognizing National Preparedness Month - September 2013

AGENDA
August 27, 2013

**AGENDA
JOINT MEETING OF THE
CITY COUNCIL OF THE CITY OF MORENO VALLEY
MORENO VALLEY COMMUNITY SERVICES DISTRICT
CITY AS SUCCESSOR AGENCY FOR THE
COMMUNITY REDEVELOPMENT AGENCY OF THE
CITY OF MORENO VALLEY
MORENO VALLEY HOUSING AUTHORITY
AND THE BOARD OF LIBRARY TRUSTEES**

***THE CITY COUNCIL RECEIVES A SEPARATE STIPEND FOR CSD
MEETINGS***

**REGULAR MEETING - 6:00 PM
AUGUST 27, 2013**

CALL TO ORDER

(Joint Meeting of the City Council, Community Services District, City as Successor Agency for the Community Redevelopment Agency, Housing Authority and the Board of Library Trustees - actions taken at the Joint Meeting are those of the Agency indicated on each Agenda item)

PLEDGE OF ALLEGIANCE

INVOCATION

Captain Julius Murphy - The Salvation Army - Moreno Valley Corps

ROLL CALL

INTRODUCTIONS

PUBLIC COMMENTS ON MATTERS ON THE AGENDA WILL BE TAKEN UP AS THE ITEM IS CALLED FOR BUSINESS, BETWEEN STAFF'S REPORT AND CITY COUNCIL DELIBERATION (SPEAKER SLIPS MAY BE TURNED IN UNTIL THE ITEM IS CALLED FOR BUSINESS.)

PUBLIC COMMENTS ON ANY SUBJECT NOT ON THE AGENDA UNDER THE JURISDICTION OF THE CITY COUNCIL

Those wishing to speak should complete and submit a BLUE speaker slip to the Bailiff. There is a three-minute time limit per person. All remarks and questions shall be addressed to the presiding officer or to the City Council and not to any individual Council member, staff member or other person.

AGENDA
August 27, 2013

JOINT CONSENT CALENDARS (SECTIONS A-D)

All items listed under the Consent Calendars, Sections A, B, C, and D are considered to be routine and non-controversial, and may be enacted by one motion unless a member of the City Council, Community Services District, City as Successor Agency for the Community Redevelopment Agency, Housing Authority or the Board of Library Trustees requests that an item be removed for separate action. The motion to adopt the Consent Calendars is deemed to be a separate motion by each Agency and shall be so recorded by the City Clerk. Items withdrawn for report or discussion will be heard after public hearing items.

A. CONSENT CALENDAR-CITY COUNCIL

A.1 ORDINANCES - READING BY TITLE ONLY

Recommendation: Waive reading of all Ordinances.

A.2 MINUTES - REGULAR MEETING OF JULY 9, 2013 (Report of: City Clerk's Department)

Recommendation:

1. Approve as submitted.

A.3 CITY COUNCIL REPORTS ON REIMBURSABLE ACTIVITIES (Report of: City Clerk's Department)

Recommendation:

1. Approve as submitted.

A.4 AUTHORIZE SUBMISSION OF GRANT FUNDING APPLICATIONS FOR RIVERSIDE COUNTY TRANSPORTATION COMMISSION'S MULTI-FUNDING CALL FOR PROJECTS AND APPROVE RESOLUTION 2013-65 (Report of: Public Works Department)

Recommendations

1. Authorize the submittal of grant applications for the Riverside County Transportation Commission's (RCTC) Multi-funding Call for Projects.
2. Approve Resolution No. 2013-65. A Resolution of the City Council of the City of Moreno Valley, California indicating the City's commitment to provide a funding match for projects selected as a part of the RCTC Multi-funding Call for Projects. Resolution No. 2013-65, a Resolution of the City Council of the City of Moreno Valley, California, authorizing the submittal of applications for the RCTC Multi-Funding Call for Projects and Matching Fund Commitment

- A.5 AWARD THE PURCHASE OF EMERGENCY VEHICLE PRE-EMPTION EQUIPMENT TO GLOBAL TRAFFIC TECHNOLOGIES FOR RETROFITTING 117 EXISTING SIGNALIZED INTERSECTIONS— PROJECT NO. 808 0010 70 76 (Report of: Public Works Department)

Recommendations

1. Award the purchase of Emergency Vehicle Pre-emption systems for Project No. 808 0010 70 76 to Global Traffic Technologies.
2. Authorize the Purchasing & Facilities Division Manager to execute a Purchase Order to Global Traffic Technologies, in the amount of \$319,062.39 (\$282,356.10 for the bid amount, plus sales tax and 5% contingency) - Account No. 3302-70-76-80008-660310).

- A.6 APPROVAL OF PAYMENT REGISTER FOR MAY, 2013 (Report of: Financial & Management Services Department)

Recommendation:

1. Adopt Resolution No. 2013-66, approving the Payment Register for the month of May, 2013 in the amount of \$12,527,069.50. Resolution No. 2013-66, A Resolution of the City Council of the City of Moreno Valley, California, Approving the Payment Register for the Month of May, 2013.

- A.7 APPROVAL OF PAYMENT REGISTER FOR JUNE, 2013 (Report of: Financial & Management Services Department)

Recommendation:

1. Adopt Resolution No. 2013-67, approving the Payment Register for the month of June, 2013 in the amount of \$22,008,214.83. A Resolution of the City Council of the City of Moreno Valley, California Approving the Payment Register for the Month of June, 2013.

- A.8 RECEIPT OF QUARTERLY INVESTMENT REPORT – QUARTER ENDED JUNE 30, 2013 (Report of: Financial & Management Services Department)

Recommendation:

1. Receive and file the Quarterly Investment Report, in compliance with the City's Investment Policy.

- A.9 ADOPT RESOLUTION NO. 2013-68 APPROVING THE RELOCATION PLAN FOR ELIGIBLE OCCUPANTS OF A SINGLE FAMILY RESIDENCE LOCATED AT 13597 NASON STREET (APN 487-470-017) FOR THE NASON STREET FROM CACTUS AVENUE TO FIR AVENUE STREET IMPROVEMENT PROJECT – PROJECT NO. 801 0001 70 77 (Report of: Public Works Department)

Recommendation:

1. Adopt Resolution No. 2013-68. A Resolution of the City Council of the City of Moreno Valley, California approving the Relocation Plan for eligible occupants of a single family residence located at 13597 Nason Street (APN: 487-470-017). Resolution No. 2013-68, a Resolution of the City Council of the City of Moreno Valley, California, Approving the Relocation Plan for Eligible Occupants of a single family residence located at 13597 Nason Street (APN 487-470-017) for the Nason Street from Cactus Avenue to Fir Avenue Street Improvement Project – Project No. 801 0001 70 77.

A.10 RIGHT OF WAY EASEMENTS (APNS 487-470-023 AND 487-470-026) AND DRAINAGE EASEMENT (APN 487-470-023) FOR THE NASON STREET FROM CACTUS AVENUE TO FIR AVENUE STREET IMPROVEMENT PROJECT - PROJECT NO. 801 0001 70 77 (Report of: Public Works Department)

Recommendations

1. Adopt Resolution No. 2013-69. A Resolution of the City Council of the City of Moreno Valley, California, granting a roadway easement on City owned parcels fronting the west side of Nason Street between Alessandro Boulevard and Cottonwood Avenue known as Assessor Parcel Numbers 487-470-023 and 487-470-026.
2. Authorize the granting of roadway easements for the City owned parcels known as Assessor Parcel Numbers 487-470-023 and 487-470-026.
3. Direct the City Clerk to forward the Resolution to the Mayor for execution and the roadway Easement Deeds to the Public Works Director/City Engineer for execution and to forward the documents to the County Recorder's office for recordation for Assessor Parcel Numbers 487-470-023 and 487-470-026.
4. Adopt Resolution No. 2013-70. A Resolution of the City Council of the City of Moreno Valley, California, granting a drainage easement on a City owned parcel on the northwest corner of Alessandro Boulevard and Nason Street known as Assessor Parcel Number 487-470-023.
5. Authorize the granting of a drainage easement for the City owned parcel known as Assessor Parcel Number 487-470-023.
6. Direct the City Clerk to forward the Resolution for Assessor Parcel

AGENDA
August 27, 2013

Number 487-470-023 to the Mayor for execution and the Drainage Easement to the Public Works Director/City Engineer for execution and to forward the documents to the County Recorder's office for recordation for Assessor Parcel Number 487-470-023.

A.11 APPROVE BIO-TOX LABORATORIES PURCHASE ORDER FOR \$125,000 (Report of: Police Department)

Recommendation:

1. Authorize the Moreno Valley Police Department to execute a Purchase Order to Bio-Tox Laboratories, 1965 Chicago Ave. #C, Riverside, CA 92507, for \$125,000 (Account No. 1010-60-65-40010-625099)

A.12 PA07-0080 (PM 35672) – APPROVE PARCEL MAP AND ACCEPT THE AGREEMENT AND SECURITY FOR PUBLIC IMPROVEMENTS (Report of: Public Works Department)

Recommendations

1. Approve Parcel Map 35672 and authorize the City Clerk to sign the map and transmit said map to the County Recorder's Office for recordation.
2. Accept the Agreement and Security for Public Improvements.
3. Authorize the Mayor to execute the Agreement.
4. Direct the City Clerk to forward the signed Agreement to the County Recorder's Office for recordation.
5. Authorize the City Engineer to execute any future time extension amendments to the agreement, subject to City Attorney approval, if the required public improvements are not completed within said timeframe.

A.13 PA13-0012 – APPROVAL OF PROPOSED RESOLUTION FOR THE VACATION OF A PORTION OF JOY STREET FROM CACTUS AVENUE TO BRODIAEA AVENUE (Report of: Public Works Department)

Recommendations

1. Adopt the Resolution No. 2013-71. A Resolution of the City Council of the City of Moreno Valley, California, ordering the vacation of a portion of Joy Street from Cactus Avenue to Brodiaea Avenue.
2. Direct the City Clerk to certify said resolution and transmit a copy of the resolution to the County Recorder's office for recording.

AGENDA
August 27, 2013

A.14 RECOMMENDATION TO ESTABLISH THE CLASSIFICATION OF RECYCLING SPECIALIST IN THE PUBLIC WORKS DEPARTMENT (Report of: Administrative Services Department)

Recommendation:

1. Adopt the new position, class specification and salary range of the Recycling Specialist in the Public Works Department.

B. CONSENT CALENDAR-COMMUNITY SERVICES DISTRICT

B.1 ORDINANCES - READING BY TITLE ONLY

Recommendation: Waive reading of all Ordinances.

B.2 MINUTES - REGULAR MEETING OF JULY 9, 2013 (Report of: City Clerk's Department)

Recommendation:

1. Approve as submitted.

B.3 REPLACEMENT OF PLAY STRUCTURES AND PLAYGROUND SURFACING AT FAIRWAY PARK, EL POTRERO PARK, AND WESTBLUFF PARK (Report of: Parks & Community Services Department)

Recommendations

1. Award Purchase Order to Miracle Recreation Equipment Company, 8445 Solution Center, Chicago, IL 60677-8004 for material and labor to replace play structures and playground surfacing at Fairway Park, El Potrero Park, and Westbluff Park.
2. Authorize the Purchasing Manager to execute a purchase order in an amount not to exceed \$381,928.11 as appropriated in FY13/14, in GL account 3006-50-57-80007-720199, project number 807 0004 50 57 3006Q.
3. Authorize the issuance of a Purchase Order to Miracle Recreation Equipment Company, in the amount of \$381,928.11 (\$356,928.11 for the bid amount plus 7% contingency) when the contract has been signed by all parties.
4. Authorize the Parks and Community Services Director to execute any subsequent change orders to the contract with Miracle Recreation Equipment Company, up to but not to exceed the Purchase Order contingency of \$25,000 subject to the approval of the City Attorney.
5. Authorize the Parks and Community Services Director to accept the

AGENDA
August 27, 2013

improvements into the Community Services District's maintained system upon acceptance of the improvements as complete.

- B.4 AMEND THE CONTRACT WITH THINK TOGETHER, INC., TO OPERATE DAY-TO-DAY ACTIVITIES AND FUNCTIONS INVOLVING THE CITY'S AFTER SCHOOL EDUCATION AND SAFETY (ASES) GRANT PROGRAM FOR FISCAL YEAR 2013-14 THROUGH FISCAL YEAR 2015-16 (Report of: Parks & Community Services Department)

Recommendations

1. Authorize the City Manager to amend the contract entered into with THINK Together, Inc., on April 26, 2011, to operate day-to-day activities and functions of the City's Prop 49 state-funded ASES after school grant program, as outlined within this document.
2. Authorize the additional revenue and expense budgets in the ASES Program Grant Fund (Fund 2202) for the ASES Grant Program in the amount of \$520,050, respectively, upon approval of the contract amendment with THINK Together, Inc.

- B.5 ACCEPTANCE OF GRANT MONIES FROM THE CALIFORNIA DEPARTMENT OF EDUCATION, CHILD DEVELOPMENT SERVICES, FOR CHILD CARE SERVICES AND ADOPTION OF THE RESOLUTION TO CERTIFY THE APPROVAL OF THE GOVERNING BOARD (Report of: Parks & Community Services Department)

Recommendations

1. Authorize the acceptance of grant money in the amount of \$547,461 for Fiscal Year (FY) 2013/2014 from the California Department of Education, Child Development Division, for the purpose of providing school age child care and development services.
2. Adopt Resolution No. CSD 2013-16. A Resolution of the Moreno Valley Community Services District of the City of Moreno Valley, California, certifying the approval of the governing board to enter into this transaction with the California Department of Education for the purpose of providing child care and development services and to authorize the designated personnel, to sign contract documents for FY 2013/2014.

- B.6 SECOND EXTENSION OF THE AGREEMENT – PROJECT NO. 2011 TREE TRIM/REMOVAL MAINTENANCE (Report of: Financial & Management Services Department)

Recommendations

1. Approve the Second Extension of the Agreement (“Second Extension

Agreement”) for Project No. 2011, Tree Trim/Removal Services, with West Coast Arborists, Inc., 2200 E. Burton Street, Anaheim, CA 92806 for tree trimming and removal services within Community Services District (CSD) zones D, E-1, E-1A, E-2, E-3, E-4, E-7, E-8, E-12, E-14, E-15, E-16, M and S.

2. Authorize the City Manager to execute the Second Extension Agreement for tree trimming/removal services with West Coast Arborists, Inc.
3. Authorize the issuance of a purchase order for services beginning September 1, 2013 to West Coast Arborists, Inc., in the not-to-exceed (NTE) amount of \$97,050.00. This amount includes \$82,705.00 for base and \$14,345.00 for additional work.
4. Authorize the City Manager to execute subsequent Extensions or Amendments to the Agreement, within Council approved annual budgeted amounts, including the authority to authorize the associated purchase order (P.O.) in accordance with the terms of the Agreement, subject to the approval of the City Attorney.

C. CONSENT CALENDAR - HOUSING AUTHORITY

C.1 ORDINANCES - READING BY TITLE ONLY

Recommendation: Waive reading of all Ordinances.

C.2 MINUTES - REGULAR MEETING OF JULY 9, 2013 (Report of: City Clerk's Department)

Recommendation:

1. Approve as submitted.

D. CONSENT CALENDAR - BOARD OF LIBRARY TRUSTEES

D.1 ORDINANCES - READING BY TITLE ONLY

Recommendation: Waive reading of all Ordinances.

D.2 MINUTES - REGULAR MEETING OF JULY 9, 2013 (Report of: City Clerk's Department)

Recommendation:

1. Approve as submitted.

E. PUBLIC HEARINGS - None

Questions or comments from the public on a Public Hearing matter are limited to five minutes per individual and must pertain to the subject under consideration. Those wishing to speak should complete and submit a GOLDENROD speaker slip to the Bailiff.

F. ITEMS REMOVED FROM CONSENT CALENDARS FOR DISCUSSION OR SEPARATE ACTION

G. REPORTS

- G.1 PUBLIC MEETING REGARDING THE MAIL BALLOT PROCEEDING FOR APN 291-650-011 BALLOTING FOR NPDES (Report of: Financial & Management Services Department)

Recommendations That the City Council:

1. Accept public comments regarding the mail ballot proceeding for Assessor Parcel Number (APN) 291-650-011 for approval of the National Pollutant Discharge Elimination System (NPDES) maximum commercial/industrial regulatory rate.

- G.2 MONTHLY REPORT: MORENO VALLEY ANIMAL SHELTER ADOPTION RATE (Report of: Administrative Services Department)

Recommendations That the City Council:

1. Receive and file the Monthly Report: Moreno Valley Animal Shelter Adoption Rate for the periods of May 1, 2013 to May 31, 2013 and June 1, 2013 to June 30, 2013.

- G.3 APPOINT A VOTING DELEGATE AND ALTERNATE DELEGATES FOR THE LEAGUE OF CALIFORNIA CITIES (LCC) 2013 ANNUAL CONFERENCE BUSINESS MEETING (Report of: City Clerk Department)

Recommendations That the City Council:

1. Appoint a voting delegate, and first and second alternate delegates for the League of California Cities (LCC) 2013 Annual Conference business meeting.

- G.4 2013 COUNCIL COMMITTEE PARTICIPATION APPOINTMENTS TO VACANT POSITIONS (Report of: City Clerk Department)

Recommendations That the City Council:

1. Appoint Council Member Victoria Baca to serve as the City of Moreno Valley's representative on the March Joint Powers Commission (MJPC).

AGENDA
August 27, 2013

2. Appoint Council Member Jesse L. Molina to serve as the City of Moreno Valley's alternate representative on the Riverside County Transportation Commission (RCTC).
3. Appoint Council Member Victoria Baca to serve as the City of Moreno Valley's alternate representative on the Riverside Transit Agency (RTA).
4. Appoint Council Member Jesse L. Molina to serve as the City of Moreno Valley's alternate representative on the Western Riverside Council of Governments (WRCOG).
5. Appoint Council Member Jesse L. Molina to serve on the City of Moreno Valley's Economic Development Subcommittee.
6. Appoint Council Member Jesse L. Molina to serve on the City of Moreno Valley's Finance Subcommittee.
7. Appoint Council Member Victoria Baca to serve as the alternate on the City of Moreno Valley's Public Safety Subcommittee.

G.5 DISCUSSION AND APPOINTMENT REGARDING MAYOR PRO TEM POSITION (Report of: City Clerk Department)

Recommendations That the City Council:

1. Select a Council Member to serve as Mayor Pro Tem for the remainder of the unexpired term.

G.6 APPOINTMENTS TO THE CITY COUNCIL ADVISORY BOARDS AND COMMISSIONS (Report of: City Clerk's Department)

Recommendations That the City Council:

1. Extend the expiring August 31, 2013 terms of the current City Council Advisory Board and Commission members to October 31, 2013 to allow additional time for recruitment.

G.7 CITY MANAGER'S REPORT (Informational Oral Presentation - not for Council action)

G.8 CITY ATTORNEY'S REPORT (Informational Oral Presentation - not for Council action)

H. LEGISLATIVE ACTIONS

H.1 ORDINANCES - 1ST READING AND INTRODUCTION - NONE

H.2 ORDINANCES - 2ND READING AND ADOPTION - NONE

H.3 ORDINANCES - URGENCY ORDINANCES - NONE

H.4 RESOLUTIONS - NONE

CLOSING COMMENTS AND/OR REPORTS OF THE CITY COUNCIL, COMMUNITY SERVICES DISTRICT, CITY AS SUCCESSOR AGENCY FOR THE COMMUNITY REDEVELOPMENT AGENCY OR HOUSING AUTHORITY

Materials related to an item on this Agenda submitted to the City Council/Community Services District/City as Successor Agency for the Community Redevelopment Agency/Housing Authority or Board of Library Trustees after distribution of the agenda packet are available for public inspection in the City Clerk's office at 14177 Frederick Street during normal business hours.

CLOSED SESSION

A Closed Session of the City Council, Community Services District, City as Successor Agency for the Community Redevelopment Agency and Housing Authority will be held in the City Manager's Conference Room, Second Floor, City Hall. The City Council will meet in Closed Session to confer with its legal counsel regarding the following matter(s) and any additional matter(s) publicly and orally announced by the City Attorney in the Council Chamber at the time of convening the Closed Session.

- **PUBLIC COMMENTS ON MATTERS ON THE CLOSED SESSION AGENDA UNDER THE JURISDICTION OF THE CITY COUNCIL**

There is a three-minute time limit per person. Please complete and submit a BLUE speaker slip to the City Clerk. All remarks and questions shall be addressed to the presiding officer or to the City Council and not to any individual Council member, staff member or other person.

The Closed Session will be held pursuant to Government Code:

1 **SIGNIFICANT EXPOSURE TO LITIGATION PURSUANT TO PARAGRAPH (2) OR (3) OF SUBDIVISION (D) OF SECTION 54956.9**

Number of Cases: 5

2 **SECTION 54956.9(d)(4) - CONFERENCE WITH LEGAL COUNSEL - INITIATION OF LITIGATION**

Number of Cases: 5

REPORT OF ACTION FROM CLOSED SESSION, IF ANY, BY CITY ATTORNEY

ADJOURNMENT

CERTIFICATION

I, Jane Halstead, City Clerk of the City of Moreno Valley, California, certify that the City Council Agenda was posted in the following places pursuant to City of Moreno Valley Resolution No. 2007-40:

City Hall, City of Moreno Valley
14177 Frederick Street

AGENDA
August 27, 2013

Moreno Valley Library
25480 Alessandro Boulevard

Moreno Valley Senior/Community Center
25075 Fir Avenue

Jane Halstead, CMC,
City Clerk

Date Posted: 8/21/2013

This page intentionally left blank.

MINUTES
CITY COUNCIL REGULAR MEETING OF THE CITY OF MORENO VALLEY
July 9, 2013

CALL TO ORDER

SPECIAL PRESENTATIONS

1. Presentation of 4th of July Parade Awards
2. Business Spotlight
 - a) Fix Auto Moreno Valley
 - b) Estates, Furniture, Cabinets & Flooring

**MINUTES
JOINT MEETING OF THE
CITY COUNCIL OF THE CITY OF MORENO VALLEY
MORENO VALLEY COMMUNITY SERVICES DISTRICT
CITY AS SUCCESSOR AGENCY FOR THE
COMMUNITY REDEVELOPMENT AGENCY OF
THE CITY OF MORENO VALLEY
MORENO VALLEY HOUSING AUTHORITY
BOARD OF LIBRARY TRUSTEES**

**REGULAR MEETING – 6:00 PM
July 9, 2013**

CALL TO ORDER

The Joint Meeting of the City Council of the City of Moreno Valley, Moreno Valley Community Services District, City as Successor Agency for the Redevelopment Agency of the City of Moreno Valley, Moreno Valley Housing Authority and the Board of Library Trustees was called to order at 6:08 p.m. by Mayor Tom Owings in the Council Chamber located at 14177 Frederick Street.

PLEDGE OF ALLEGIANCE

The Pledge of Allegiance was led by Frank Wright

INVOCATION - Dr. Janet Wallace - Agape Fellowship

ROLL CALL

Council:

Tom Owings	Mayor
Marcelo Co	Mayor Pro Tem
Victoria Baca	Council Member
Jesse L. Molina	Council Member
Richard A. Stewart	Council Member

Staff:

Jane Halstead	City Clerk
Kathy Gross	Executive Assistant
Richard Teichert	Chief Financial Officer/City Treasurer
Suzanne Bryant	City Attorney
Michelle Dawson	City Manager
Joel Ontiveros	Police Chief
Abdul Ahmad	Fire Chief
Ahmad Ansari	Public Works Director

Tom DeSantis
Mike McCarty
John Terell

Assistant City Manager
Parks & Community Services Director
Interim Community and Economic Development
Director

City Attorney, Suzanne Bryant, stated an issue has arisen that necessitates that a matter listed on the agenda under Closed Session be taken out of order. If the Council votes to go into Closed Session now, we will be discussing one item under Significant Exposure to Litigation pursuant to Government Code Section 54956.9 as listed on the agenda. A vote is needed to go into Closed Session now. No reportable action is anticipated. The other items listed on the Closed Session agenda will be discussed after the regular part of the meeting.

Motion to Approve discussing one item out of order listed on the Closed Session under Significant Exposure to Litigation Pursuant to Government Code Section 54956.9 by m/Mayor Pro Tem Marcelo Co, s/Council Member Richard A. Stewart

Approved by a vote of 5-0.

Adjourned to Closed Session at 6:16 p.m.

Reconvened from Closed Session at 6:22 p.m. There was no reportable action at this time.

PUBLIC COMMENTS ON ANY SUBJECT NOT ON THE AGENDA UNDER THE JURISDICTION OF THE CITY COUNCIL

Mary Anne Gonzales

1. Development Growth
2. Negative Environment

Connie Pat

1. New resident with concerns
2. Negative comments against council

Danny Morales

1. Democracy

2. Recalls
3. Supports Council Member Victoria Baca and Jesse Molina

Raquel C.

1. Thank you for keeping the Morrison Park Fire Station

Louise Palomarez

1. 4th of July event, was a great concert and compliments to Parks & Community Services Director Mike McCarty

Chris Baca

1. Commends the City on the 4th of July event
2. Immigration Reform

Betty Masters

1. World Logistics Center (Opposed)

Tom Thornsley

1. World Logistics Center
2. Upcoming meeting will be held at Moreno Valley High School on July 13th from 10 a.m. - 12 p.m. to discuss the impacts of these types of warehouses.
3. Speaker Slips

Nicolas Gomez

1. Immigration Reform

Robert Palomarez

1. 4th of July was a blast and Parks & Community Services Director Mike McCarty did a great job.

Susan Owings

1. Public Safety costs
2. March Joint Powers Authority

Frank Wright

1. City Administration

Debra Craig

1. Recall

Alicia Espinoza

1. Recall

Curtis Gardner

1. Jobs

Craig Givens

1. March Joint Powers
2. Warehouses

Veronica Landaverde

1. Immigration Reform

Deanna Reeder

1. 4th of July event was great
2. Community Awareness Meeting
3. Speakers being interrupted/discriminated
4. Recall
5. Lawsuit mentioned

Tom Jerele Sr.

1. MVTV-3 congratulations on Emmy Nomination
2. Crossing Guard Continuation
3. 4th of July event
4. Recall

Scott Heveran

1. Speakers

Valerie Perris

1. New Resident
2. Medical Corridor

JOINT CONSENT CALENDARS (SECTIONS A-D) OF THE CITY COUNCIL OF THE CITY OF MORENO VALLEY, MORENO VALLEY COMMUNITY SERVICES DISTRICT, CITY AS SUCCESSOR AGENCY FOR THE COMMUNITY REDEVELOPMENT AGENCY OF THE CITY OF MORENO VALLEY, MORENO VALLEY HOUSING AUTHORITY AND THE BOARD OF LIBRARY TRUSTEES

Mayor Tom Owings opened the agenda items for the Consent Calendars for public comments, which were received from Chris Baca (A.4), Jeff Giba (B.3, Supports), Deanna Reeder (A.7, A.9 (Opposed) and A.11), Scott Heveran (A.6), Marcia Amino (A.9, A.19), Susan Gilchrist (A.9, A.17), Craig Givens (A.4), Tom Thornsley (A.9), and Louise Palomarez (A.4).

A. CONSENT CALENDAR-CITY COUNCIL

A.1 ORDINANCES - READING BY TITLE ONLY

Recommendation: Waive reading of all Ordinances.

A.2 MINUTES - REGULAR MEETING OF JUNE 25, 2013 (Report of: City Clerk's Department)

Recommendation:

Approved as submitted.

A.3 CITY COUNCIL REPORTS ON REIMBURSABLE ACTIVITIES (Report of: City Clerk's Department)

Recommendation:

Approved as submitted.

A.4 REQUEST TO CONDUCT A FULL ROAD CLOSURE OF GILMAN SPRINGS ROAD IN SUPPORT OF RIVERSIDE COUNTY RECONSTRUCTION PROJECT (Report of: Public Works Department)

Recommendations

1. Authorize a full road closure of Gilman Springs Road from SR60 to approximately 1.7 miles southerly of Alessandro Boulevard from September 15, 2013 to November 15, 2013.
2. Authorize the City Engineer to allow for an additional 30-day extension to the proposed road closure window if the project is delayed due to unforeseen construction issues.

- A.5 ANNUAL STATEMENT OF INVESTMENT POLICY
(Report of: Financial & Management Services Department)

Recommendation:

Adopt the Annual Statement of Investment Policy

- A.6 APPROVE A RESOLUTION OF THE CITY COUNCIL OF THE CITY OF MORENO VALLEY, CALIFORNIA, TO AMEND THE ELECTRIC RATES FOR MORENO VALLEY UTILITY
(Report of: Public Works Department)

Recommendations

Approve Resolution No. 2013-48 amending the Electric Rates for Moreno Valley Utility. A Resolution of the City Council of the City of Moreno Valley, California, to Amend the Electric Rates, and Electric Service Rules, Fees, and Charges for Moreno Valley Utility.

- A.7 AGREEMENT FOR ON-CALL LEGAL SERVICES
(Report of: City Attorney Department)

Recommendations

1. Approve and authorize the City Attorney to execute the Agreement for On-Call Legal Services with Meyers Nave.
2. Authorize the City Attorney to execute subsequent extensions or amendments subject to budget constraints and approvals.

- A.8 APPROVE MEMORANDUM OF UNDERSTANDING WITH THE CITY OF RIVERSIDE OFFICE OF EMERGENCY MANAGEMENT REGARDING URBAN AREA SECURITY INITIATIVE (UASI) GRANT FUNDING FOR FEDERAL FISCAL YEAR 2011
(Report of: Fire Department)

Recommendations

1. Adopt Resolution No. 2013-62 of the City of Moreno Valley, California, approving the Memorandum of Understanding with the City of Riverside Office of Emergency Management regarding the Urban Area Security Initiative (UASI) grant funding for Federal Fiscal Year 2011. A Resolution of the City Council of the City of Moreno Valley, California, Authorizing the City to Enter into a Memorandum of Understanding With the City of Riverside Office of Emergency Management Regarding Urban Area Security Initiative (UASI) Grant Funding for Federal Fiscal Year 2011.

2. Authorize the allocation of \$8,000 for expenditures related to the UASI grant funding for Federal Fiscal Year 2011 not to exceed the amount of grant award.
3. Authorize the City Manager or her designee to execute the Certificate of Non-Supplanting.
4. Authorize the City Manager or her designee to execute the Riverside Urban Area Security Initiative Certification Regarding Debarment, Suspension, and other Responsibility Matters.
5. Authorize the City Manager or her designee to execute the California Emergency Management Agency Fiscal Year (FY) 2011 Grant Assurances.
6. Accept the grant award from the City of Riverside Office of Emergency Management regarding the Urban Area Security Initiative (UASI) grant funding for Federal Fiscal Year 2011.

A.9 AUTHORIZATION TO AWARD AGREEMENT FOR PROFESSIONAL CONSULTANT SERVICES TO RBF CONSULTING FOR THE STATE ROUTE 60/THEODORE STREET INTERCHANGE IMPROVEMENTS - PROJECT NO. 801 0052 70 77
(Report of: Public Works Department)

Recommendations

1. Approve the Agreement for Professional Consultant Services with RBF Consulting, 3300 East Guasti Road, Suite 100, Ontario, CA 91761, to provide design services for a total contract not to exceed \$1,750,183.
2. Authorize the City Manager to execute the Agreement for Professional Consultant Services with RBF Consulting.
3. Authorize the issuance of a Purchase Order with RBF Consulting totaling \$1,750,183 when the Agreement has been signed by all parties.
4. Authorize the Public Works Director/City Engineer to execute any subsequent related amendments to the Agreement for Professional Consultant Services with RBF Consulting, not to exceed the Purchase Order amount, subject to the approval by the City Attorney.
5. Authorize the re-appropriation of \$2,000,000 in realized project savings from the Cactus Avenue/Nason Street Improvement project

to the SR-60/Theodore Street Interchange Improvements project.

- A.10 AUTHORIZATION OF GRANT APPLICATION SUBMITTALS FOR CYCLE 6 OF THE HIGHWAY SAFETY IMPROVEMENT PROGRAM (HSIP)
(Report of: Public Works Department)

Recommendation:

Authorize the submittal of grant applications for Cycle 6 of the Highway Safety Improvement Program (HSIP).

- A.11 AUTHORIZATION OF ANNUAL TECHNOLOGY SOFTWARE AND HARDWARE MAINTENANCE PAYMENTS AND WAIVING FORMAL BIDDING AND INSURANCE REQUIREMENTS FOR THESE PAYMENTS
(Report of: Financial & Management Services Department)

Recommendations

1. Waive the formal bidding requirements for technology annual maintenance payments.
2. Waive the insurance requirements for technology annual maintenance payments.
3. Authorize the City Manager to make technology annual maintenance payments to various vendors for an aggregate amount not-to-exceed \$850,069 during Fiscal Year 2013-14 according to the schedule.

- A.12 ACCEPTANCE OF DONATION IN THE AMOUNT OF \$12,214 BY THE MORENO VALLEY FRIENDS OF THE LIBRARY FOR THE MORENO VALLEY PUBLIC LIBRARY
(Report of: Administrative Services Department)

Recommendations

1. Accept a monetary donation from the Moreno Valley Friends of the Library in the amount of \$12,214.
2. Authorize the increase of \$12,214 to the Moreno Valley Library FY 2012-13 operating budget.
3. Renew the annual subscription to BookLetters, which supports the Library's page on the City web site.

- A.13 AUTHORIZE A CHANGE ORDER TO INCREASE THE PURCHASE ORDER WITH ALL-AMERICAN ASPHALT FOR SR-60/NASON STREET INTERCHANGE IMPROVEMENTS –
PROJECT NO. 801 0012 70 77
(Report of: Public Works Department)

Recommendations

1. Authorize a Change Order to increase the existing Purchase Order with All-American Asphalt, in the amount of \$39,091 for the SR-60/Nason Street Interchange Improvements.
2. Authorize the City Manager to execute the Change Order to the Purchase Order for All-American Asphalt.
3. Authorize the Public Works Director/City Engineer to execute any subsequent Contract Change Orders to the construction contract with All-American Asphalt up to, but not exceeding, the new increased Purchase Order amount, subject to approval of the City Attorney.
4. Authorize the Public Works Director/City Engineer to accept the work as complete when all contract requirements, punch-list items, and Caltrans acceptance is completed by the Contractor.
5. Authorize the Public Works Director/City Engineer to record the Notice of Completion and accept the improvements into the City's maintained system upon acceptance of the improvements as complete.

- A.14 AGREEMENT FOR AUTOMATED LIBRARY SERVICES DURING FISCAL YEARS 2013/2014 THROUGH 2015/2016
(Report of: Administrative Services Department)

Recommendation:

Approve the Agreement for Automated Library Services between Riverside County Library System and the City of Moreno Valley, for the period July 1, 2013, through June 30, 2016.

- A.15 APPROVAL OF PAYMENT REGISTER FOR APRIL, 2013
(Report of: Financial & Management Services Department)

Recommendation:

Adopt Resolution No. 2013-63, Approving the Payment Register for the month of April, 2013 in the amount of \$17,065,756.74. A Resolution of the City Council of the City of Moreno Valley, California, Approving the Payment Register for the Month of April, 2013.

- A.16 AUTHORIZATION FOR THE MAYOR TO SIGN THE SECOND AMENDMENT TO THE SETTLEMENT AGREEMENT AND MUTUAL RELEASE FOR THE RIVERSIDE SUPERIOR COURT CASE ENTITLED RADOS, ET AL. V. CITY OF MORENO VALLEY

(Report of: City Attorney Department)

Recommendation:

Staff recommends that the City Council authorize the Mayor to sign the Second Amendment to the Settlement Agreement in the case Rados, et al. v. City of Moreno Valley (Riverside Superior Court Case No. RIC 425623).

- A.17 RESOLUTION TO APPROVE A CONDITIONAL COMMITMENT BY MEANS OF A SECOND AMENDMENT TO THE AFFORDABLE HOUSING AGREEMENT (HOME) BETWEEN THE CITY OF MORENO VALLEY AND MV HEMLOCK LIMITED PARTNERSHIP, A CALIFORNIA LIMITED PARTNERSHIP

(Report of: Community & Economic Development Department)

Recommendation:

Adopt Resolution No. 2013-64, approving a Conditional Commitment by means of Second Amendment to the Affordable Housing Agreement, in the amount of \$700,000, from the City's HOME entitlement funds, by and between the City of Moreno Valley and MV Hemlock LP, a California Limited Partnership. A Resolution of the City Council of the City of Moreno Valley Approving a Conditional Commitment by Means of Second Amendment to the Affordable Housing Agreement (Home) between the City and MV Hemlock Limited Partnership, A California Limited Partnership.

- A.18 PA07-0080, PM 35672 – REQUEST TO CONDUCT A FULL ROAD CLOSURE OF INDIAN STREET FROM IRIS AVENUE TO KRAMERIA AVENUE AND IRIS AVENUE BETWEEN INDIAN AVENUE AND CONCORD WAY FOR THE CONSTRUCTION OF STREET IMPROVEMENTS FROM AUGUST 12, 2013 – NOVEMBER 1, 2013

(Report of: Community & Economic Development Department)

Recommendations

1. Authorize a full road closure of Indian Street from Iris Avenue to Krameria Avenue and Iris Avenue between Indian Avenue and Concord Way for the construction of street improvements from August 12, 2013 – November 1, 2013.
2. Authorize the City Engineer to allow for an additional 30-day extension to the proposed road closure window if the project is delayed due to unforeseen construction issues.

- A.19 APPROVE THE COOPERATIVE AGREEMENT BETWEEN THE CITY OF MORENO VALLEY, CITY OF RIVERSIDE, AND MJPA FOR THE COLLECTION AND EXPENDITURE OF FAIR SHARE TRAFFIC IMPACT MITIGATION FEES

(Report of: Public Works Department)

Recommendation:

Approve the Cooperative Agreement between the City of Moreno Valley, City of Riverside, and March Joint Powers Authority (MJPA) for the collection and expenditure of fair share impact mitigation fees for the Meridian Specific Plan located within the MJPA.

B. CONSENT CALENDAR-COMMUNITY SERVICES DISTRICT

B.1 ORDINANCES - READING BY TITLE ONLY

Recommendation: Waive reading of all Ordinances.

B.2 MINUTES - REGULAR MEETING OF JUNE 25, 2013 (Report of: City Clerk's Department)

Recommendation:

Approve as submitted.

B.3 AWARD OF AN INDEPENDENT CONTRACTOR AGREEMENT FOR PROJECT NO. E-2 (HIDDEN SPRINGS) MAINTENANCE OF PARKWAY, MEDIAN AND OPEN SPACE LANDSCAPING AND IRRIGATION (Report of: Financial & Management Services Department)

Recommendations

1. Approve the Agreement for Project No. E-2/13-14 (Hidden Springs) Maintenance of Parkway, Median and Open Space Landscaping and Irrigation with Mariposa Landscapes, Inc., 15529 Arrow Highway, Irwindale, CA 91706 for landscape maintenance services of the parkways, medians and paseos (open spaces).
2. Authorize the City Manager to execute the Agreement for Project No. E- 2/13-14 with Mariposa Landscapes, Inc.
3. Authorize the issuance of purchase orders for services beginning July 1, 2013 to Mariposa Landscapes, Inc. in the not-to-exceed (NTE) amount of \$104,282.00 (\$85,482.00 for base and \$18,800.00 for additional work).
4. Authorize the City Manager to execute subsequent Extensions or Amendments to the Agreement, including the authority to authorize associated purchase orders (P.O.s) in accordance with the terms of the Agreement, subject to the approval of the City Attorney.

C. CONSENT CALENDAR - HOUSING AUTHORITY

C.1 ORDINANCES - READING BY TITLE ONLY
Recommendation: Waive reading of all Ordinances.

C.2 MINUTES - REGULAR MEETING OF JUNE 25, 2013 (Report of: City Clerk's Department)

Recommendation:
Approve as submitted.

D. CONSENT CALENDAR - BOARD OF LIBRARY TRUSTEES

D.1 ORDINANCES - READING BY TITLE ONLY
Recommendation: Waive reading of all Ordinances.

D.2 MINUTES - REGULAR MEETING OF JUNE 25, 2013 (Report of: City Clerk's Department)

Recommendation:
Approve as submitted.

Motion to Approve Joint Consent Calendar Items A.1 through D.2 by m/Mayor Pro Tem Marcelo Co, s/Council Member Victoria Baca

Approved by a vote of 5-0.

Motion to hear Item G.2 out of order by m/Council Member Victoria Baca, s/Council Member Richard A. Stewart

Approved by a vote of 5-0.

E. PUBLIC HEARINGS

E.1 PUBLIC HEARING TO CONSIDER FEE SCHEDULE FOR FISCAL YEAR 2013-14
(Report of: Financial & Management Services Department)

Recommendations That the City Council:

1. Conduct a Public Hearing to receive public input on the proposed Fee Schedule for Fiscal Year 2013-14.
2. Adopt Resolution No. 2013-25, approving the Fee Schedule for Fiscal Year 2013-14. A Resolution of the City Council of the City of Moreno Valley, California, Establishing Specified Fees for Various

Services for Fiscal Year 2013-14 and Repealing Prior Resolutions that may be in Conflict

Mayor Tom Owings opened the public testimony portion of the public hearing. Public testimony was received from Susan Gilchrist and Tom Thornsley.

Motion to Approve Recommendation No. 2; and hold a Study Session in September 2013 to review the Fee Schedule and to revise as needed by m/Council Member Victoria Baca, s/Council Member Jesse L. Molina

Approved by a vote of 5-0.

Recess;

Reconvened.

F. ITEMS REMOVED FROM CONSENT CALENDARS FOR DISCUSSION OR SEPARATE ACTION

G. REPORTS

G.1 CITY COUNCIL REPORTS ON REGIONAL ACTIVITIES (Informational Oral Presentation - not for Council action)

a) Report by Council Member Council Member Jesse L. Molina on Riverside Transit Agency (RTA)

Council Member Jesse L. Molina reported that Riverside Transit Agency (RTA) has allowed disabled Veteran's that have the U.S. Department of Veteran's Affairs issued photo I.D. cards to ride the senior and discounted fares. Free on all RTA fixed route buses to ride free. A hearing will take place in Murrieta on July 16th from 2-3 p.m. Your new bus passes can be used to travel to the Murrieta Town hall meeting to celebrate "Dump the Pump" day, which RTA will be joining other transit agencies giving out prizes and free bus passes. The Dump the Pump day is on July 15th.

Item G.2 was discussed after the conclusion of the Joint Consent Calendars.

G.2 AUTHORIZATION TO AWARD CONTRACT TO ALL CITY MANAGEMENT SERVICES FOR THE ADMINISTRATION OF THE CROSSING GUARD PROGRAM
(Report of: Public Works Department)

Recommendations That the City Council:

1. Authorize the Award of a Crossing Guard Services Contract to All City Management Services to provide adult crossing guard services within the City commencing with the start of the 2013/2014 school year in mid-August.
2. Authorize the City Manager to execute an agreement with All City Management Services.
3. Authorize the issuance of a Purchase Order to All City Management Services in the amount of \$440,972 for the first year of the agreement and subsequent purchase orders as necessary to fund the four subsequent years of services in accordance with the terms of the agreement.
4. Authorize the Public Works Director/City Engineer to execute any subsequent amendments to the Agreement with All City Management Services, if needed, subject to the approval of the City Attorney.

Motion to pull this item 1) to revisit at the next mid-year budget; and 2) keep the current level of service until then (throughout the school year) by m/Council Member Victoria Baca, s/Council Member Jesse L. Molina

Approved by a vote of 5-0.

G.3 CITY MANAGER'S REPORT (Informational Oral Presentation - not for Council action)

City Manager and Assistant City Manager Speak to Local Groups

I was honored to be the speaker at the July 2nd meeting at Adelante, the monthly meeting of the Moreno Valley Hispanic Chamber of Commerce. I appreciate the Hispanic Chamber Board for inviting me to speak. Today Assistant City Manager Assistant City Manager Tom DeSantis and I spoke to the Moreno Valley Noon Rotary. We enjoyed sharing information with these community stakeholders and ambassadors for the community.

Helen Putnam Award Judging

I served as a judge for the 2013 Helen Putnam Award for Excellence for the League of California Cities. The Helen Putnam Award for Excellence program was designed to recognize and promote the outstanding efforts and innovative solutions made by city governments each year. There are a total of 12 categories and I judged the 18 entries submitted in the Public Safety category. Winners will be announced at the League's Annual

Conference in September.

Executive Team Participates in League Events

On June 26th I participated in a luncheon meeting hosted by Riverside County League of California Cities representative Erin Sasse for the city managers in Riverside County. The purpose of the meeting was to engage the managers in participating in regularly scheduled meetings to discuss League initiatives and items of mutual interest. Given the size of the County, this group has not been very cohesive in years past. Last night Assistant City Manager Assistant City Manager Tom DeSantis, CFO Rick Teichert, and Public Works Director Public Works Director Ahmad Ansari attended the League's Riverside County Division General meeting. Hosted by the City of Banning, the featured speaker was Randall Lewis of the Lewis Group of Companies.

July 4th Parade

As promised, with the exception of Interim Community and Economic Development Director John Terell who was out of state, ALL of your Executive Management Team participated in the July 4th parade last week and had such a fun time. Thanks to Public Works Director Ahmad Ansari and Assistant City Manager Tom DeSantis for letting us use their classic vehicles, and thank you to all of the residents lining the parade route. We enjoyed celebrating our nation's birthday with our residents and promise to participate each year as we all enjoyed ourselves very much.

Movies in the Park

This Thursday night's installment of the free movies in the park series features Kung Fu Panda 2. Bring your lawn chair, blanket, dinner, and family to the CRC, film starts at dusk.

G.4 CITY ATTORNEY'S REPORT (Informational Oral Presentation - not for Council action)

The case "Sierra Club and Residents for a Livable Moreno Valley v. City of Moreno Valley and Vogel Engineers" Riverside Superior Court Case No. RIC 1215934 was dismissed on June 24, 2013.

H. LEGISLATIVE ACTIONS

H.1 ORDINANCES - 1ST READING AND INTRODUCTION

H.2 ORDINANCES - 2ND READING AND ADOPTION

H.2.1 ORDINANCE NO. 866 - AN ORDINANCE OF THE CITY COUNCIL OF THE CITY OF MORENO VALLEY, CALIFORNIA, AMENDING

SECTION 6.02 OF CHAPTER 6 OF THE CITY OF MORENO VALLEY MUNICIPAL CODE RELATING TO REFUSE COLLECTION, TRANSFER AND DISPOSAL (RECEIVED FIRST READING AND INTRODUCTION ON JUNE 25, 2013 BY A 5-0 VOTE) (Report of: Public Works Department)

Recommendations That the City Council:

Adopt Ordinance No. 866. An Ordinance of the City Council of the City of Moreno Valley, California, amending Municipal Code Section 6.02 of Chapter 6 of the City of Moreno Valley Municipal Code Relating to Refuse Collection, Transfer and Disposal.

Motion to Approve by m/Council Member Richard A. Stewart, s/Council Member Jesse L. Molina

Approved by a vote of 5-0.

H.3 ORDINANCES - URGENCY ORDINANCES - NONE

H.4 RESOLUTIONS - NONE

CLOSING COMMENTS AND/OR REPORTS OF THE CITY COUNCIL, COMMUNITY SERVICES DISTRICT, CITY AS SUCCESSOR AGENCY FOR THE COMMUNITY REDEVELOPMENT AGENCY OR HOUSING AUTHORITY

Council Member Victoria Baca

1. 4th of July - being in the parade with her grandchildren. Fireworks show was phenomenal. Parks & Community Services Director Mike McCarty is a leader of our Parks & Community Services Department and has a lot of people working under him. It takes a long time to put an event of this size together. 4th of July is a kickoff to summer. Commends City Council for putting the funds together for an event of this size. Thank you to the Police Department of keeping everything under control; no disorderly conduct. Loved the music, it was fantastic.
2. Recalls - it's Democracy. The recalls are part of the voting process. Everyone has the right to their opinions. We have a wonderful City and City staff.
3. Budget - Very happy we have a balanced budget; not too many Cities can say that.

Mayor Pro Tem Marcelo Co

1. 4th of July was the best we have ever seen. Thank you to staff and

the volunteers. Prepare for next year to have a better event.

2. Businesses in Moreno Valley, whether it is warehouses or restaurants - we need jobs and high paying jobs.
3. Submit your suggestions to the City Council on what you would like to do to work together and bring these jobs to Moreno Valley. The businesses will not come if we continue to fight.

Council Member Jesse L. Molina

1. 4th of July event and the parade. Everyone did a great job and it is better every year.
2. Unity of Moreno Valley - work together with a common goal.
3. Immigration Reform, maybe we can look into it?
4. Businesses don't like to see fighting amongst each other or with its citizens. United we can do things together; divided we cannot go anywhere.
5. Homes with children dream and come back giving and serving the community.
6. Thank you for voicing your opinions. We do listen.

Council Member Richard A. Stewart

1. 4th of July event and parade. Missed the fireworks in town, but we saw it from on top of the hill for the first time. Color Guard and posse, is a sworn officer and reserve riding his own horse.
2. Good news: Stater Bros. bought the Albertson's building. New restaurants coming to town.
3. Attended Moss Bros. ribbon cuttings with Council Member Victoria Baca - Volkswagen, GMC and Chevrolet.
4. Four Alarm fire last week in Moreno Valley storage shed. 23 engines and 3 truck companies. Very impressed with the Fire Department and how they handled this fire.
5. August 28 - Town hall meeting with Chief Ontiveros in District 2 and the Sunnymead Ranch Homeowners Association.
6. Miguel's Jr.
7. Recalls - More information coming out in August. It's not always what you think.

Mayor Tom Owings

1. Jeff Giba's remarks - credit really belongs to the City Manager, Assistant City Manager, the Public Works Director and their Division Managers have done right by us with outstanding customer satisfaction. City Manager, Michelle Dawson, and her staff have fulfilled her promises; Council has some credit, embracing standards for customer service. The Moreno Valley City Employee's Association has a lot to with embracing the initiative. Thanked Rick Teichert and Candace Cassel for their hard work. The speed of crew is speed of Captain, you deserve the same kudos. Personally thanked John Terrell and Public Works Director, Ahmad Ansari, for greatest tool to use Utilities. The senior management is an effective way to make our future brighter.

There being no further business to conduct, the meeting was adjourned at 9:50 p.m. to Closed Session by unanimous informal consent.

CLOSED SESSION

A Closed Session of the City Council, Community Services District, City as Successor Agency for the Community Redevelopment Agency and Housing Authority was held in the City Manager's Conference Room, Second Floor, City Hall. The City Council met in Closed Session to confer with its legal counsel regarding the following matter(s) and any additional matter(s) publicly and orally announced by the City Attorney in the Council Chamber at the time of convening the Closed Session.

• PUBLIC COMMENTS ON MATTERS ON THE CLOSED SESSION AGENDA UNDER THE JURISDICTION OF THE CITY COUNCIL

The Closed Session was held pursuant to Government Code:

- 1 SECTION 54956.9(d)(1) - CONFERENCE WITH LEGAL COUNSEL - EXISTING LITIGATION
 - a) [Nancy Thompson V. City of Moreno Valley](#)
 - b) [City of Moreno Valley v. Matosantos, Chiang, Angulo, March Joint Powers Authority, Successor Agency to the March Joint Powers Redevelopment Agency, et al](#)
- 2 SIGNIFICANT EXPOSURE TO LITIGATION PURSUANT TO PARAGRAPH (2) OR (3) OF SUBDIVISION (D) OF SECTION 54956.9

Number of Cases: 5

19

MINUTES
July 9, 2013

3 SECTION 54956.9(d)(4) - CONFERENCE WITH LEGAL COUNSEL - INITIATION OF LITIGATION

Number of Cases: 5

4 SECTION 54956.8 - CONFERENCE WITH REAL PROPERTY NEGOTIATOR

- a) Property: 33kV Substation Site
- City Negotiator: Ahmad R. Ansari, P.E.
- Under Negotiation: Price and terms of payment
- Owner: Moorpark Country Property
- Owners Negotiator:
- APN 316-100-028, 030, 048, 050 and 051

REPORT OF ACTION FROM CLOSED SESSION, IF ANY, BY CITY ATTORNEY

None.

ADJOURNMENT

There being no further business to conduct, the meeting was adjourned at 10:23 p.m. by unanimous informal consent.

Submitted by:

City Clerk Jane Halstead, CMC
Secretary, Moreno Valley Community Services District
Secretary, City as Successor Agency for the Community Redevelopment Agency of the City of Moreno Valley
Secretary, Moreno Valley Housing Authority
Secretary, Board of Library Trustees

Approved by:

Mayor Tom Owings
President, Moreno Valley Community Services District
Chairperson, City as Successor Agency for the Community Redevelopment Agency of the City of Moreno Valley
Chairperson, Moreno Valley Housing Authority
Chairperson, Board of Library Trustees

This page intentionally left blank.

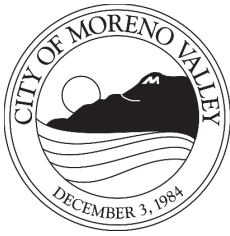

Report to City Council

TO: Mayor and City Council

FROM: Jane Halstead, City Clerk

AGENDA DATE: August 27, 2013

TITLE: CITY COUNCIL REPORTS ON REIMBURSABLE ACTIVITIES

RECOMMENDED ACTION

Recommendation:

1. Receive and file the Reports on Reimbursable Activities for the period of July 3 - August 20, 2013.

<i>Reports on Reimbursable Activities</i>			
July 3 - August 20, 2013			
Council Member	Date	Meeting	Cost
Victoria Baca	8/3/13	65 th Los Angeles Area Emmy Awards MVTV3 Recognition	\$125.00
	8/15-17/13	League of California Cities Latino Caucus – Hispanic Elected Local Officials (HELO)	\$435.08
Marcelo Co		None	
Jesse L. Molina		None	
Tom Owings	7/24/13	Moreno Valley Chamber of Commerce Wake-Up Moreno Valley	\$15.00
Richard A. Stewart	8/6/13	Moreno Valley Hispanic Chamber of Commerce Adelante	\$10.00

Prepared By:
Cindy Miller
Executive Assistant to the Mayor/City Council

Department Head Approval:
Jane Halstead
City Clerk

Council Action	
Approved as requested:	Referred to:
Approved as amended:	For:
Denied:	Continued until:
Other:	Hearing set for:

\\Zurich\shared\InterDept\Council-Clerk\City Clerk Files\Council Office\AB 1234 Reports\2013\Staff Report 2013_Reimbursable Activity 082713.doc

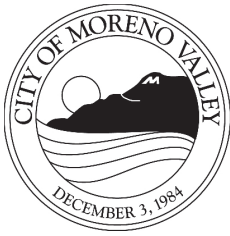

APPROVALS	
BUDGET OFFICER	<i>me</i>
CITY ATTORNEY	<i>SMB</i>
CITY MANAGER	<i>d</i>

Report to City Council

TO: Mayor and City Council

FROM: Ahmad R. Ansari, P.E., Public Works Director/City Engineer

AGENDA DATE: August 27, 2013

TITLE: AUTHORIZE SUBMISSION OF GRANT FUNDING APPLICATIONS FOR RIVERSIDE COUNTY TRANSPORTATION COMMISSION'S MULTI-FUNDING CALL FOR PROJECTS AND APPROVE RESOLUTION 2013-65

RECOMMENDED ACTION

Recommendations:

1. Authorize the submittal of grant applications for the Riverside County Transportation Commission's (RCTC) Multi-funding Call for Projects.
2. Approve Resolution No. 2013-65 indicating the City's commitment to provide a funding match for projects selected as a part of the RCTC Multi-funding Call for Projects. Resolution No. 2013-65, a Resolution of the City Council of the City of Moreno Valley, California, authorizing the submittal of applications for the RCTC Multi-Funding Call for Projects and Matching Fund Commitment

BACKGROUND

On June 25, 2013, RCTC announced the Multi-funding Call for Projects. Project Categories include the Surface Transportation Program (STP), Congestion Mitigation and Air Quality (CMAQ) program, and Measure A Regional Arterial (MARA) program. The STP funds highway and arterial roadway capacity enhancements, interchange improvements, and bridge/arterial widening. The CMAQ program funds traffic signal control systems, transit projects, and bicycle and pedestrian facilities projects. The MARA program funds arterial roadway projects in Western Riverside County.

Project selection will be based upon scoring criteria consisting of Regional Significance, Project Readiness, Local Match, Safety, Air Quality, Cost Benefit, and Regional

Transportation Plan/Sustainability Communities Strategy. Grant applications are due to RCTC by September 23, 2013.

DISCUSSION

The City is currently pursuing funding opportunities for projects that meet the intent of the RCTC Multi-funding Call for Projects program.

After considering all the requirements of the program, staff has determined several projects to be the best candidates for potential funding. Staff recommends submitting applications for the following projects based upon readiness for construction, type of environmental clearance required, and maximum available funds:

- **SR-60/Moreno Beach Drive Interchange:** The project consists of the replacement of the SR-60/Moreno Beach Drive two-lane bridge with a six-through-lane bridge, reconfiguration of the existing westbound on-ramp and off-ramp, addition of a westbound direct on-ramp, completion of a westbound auxiliary lane, and construction of a portion of Line K-1 drainage facility on Ironwood Avenue. The project is eligible for Federal funding since it already has NEPA environmental clearance. Approximately \$20 million in various funds may be requested to update the previously completed plans and specifications to current Caltrans requirements and construct this \$24 million project.
- **SR-60/Theodore Street Interchange:** This project consists of the replacement of the SR-60/Theodore Street two-lane bridge with a new wider bridge, reconfiguration of the existing ramps, and other improvements as may be identified through the planning/environmental phase. The project planning/environmental stage has just commenced. Approximately \$1 million of various types of funds may be sought for project development phase work, which could include later-phase preliminary engineering and planning.
- **Kitching Street from Cactus Avenue to Iris Avenue:** The existing roadway consists of a two-lane road with existing improvements on the east side. The proposed project will widen and improve a mile-long segment of Kitching Street to its General Plan ultimate width of four travel lanes and turning lanes at intersections. The project would include curb, gutter, minor storm drain, pavement, sidewalk, street lights, traffic signal modifications, signing and striping, and related road improvements. A total of \$2.5 million in STP funding will be requested as a part of this \$6 million project.
- **Cactus Avenue from Veteran's Way to Heacock Street:** Currently, Cactus Avenue between Heacock Street and Elsworth Street is built to three lanes westbound and two lanes eastbound. This project will widen the eastbound roadway to include an additional third lane, increasing the level of service within this segment of Cactus Avenue. Additionally, the project will modify four traffic signals, install additional raised median and median landscaping on the east leg of Graham/Cactus intersection, new curb and gutter, and asphalt concrete curbs. A total of \$1.64 million in STP funding will be requested as a part of this \$1.85 million project.

- **Transportation Management Center Phase 1B:** The project will improve mobility and air quality on several arterial roadways (portions of Eucalyptus Avenue/Towngate Boulevard, Alessandro Boulevard, Perris Boulevard, Cactus Avenue, and Lasselle Street) by enhancing the integration of the City's traffic management system via the deployment of a critical portion of the field devices and supporting communications system. Proposed improvements include an Ethernet fiber-optic backbone system, closed-circuit television cameras at 16 key intersections, and new traffic signal controllers at 45 existing signalized intersections. A total of \$1.9 million in CMAQ funding will be requested as a part of this \$2.4 million project.
- **Aqueduct Trail:** The City's Aqueduct Trail is planned to extend from the Towngate area to the Lake Perris State Recreation Area. The Trail has various segments constructed, mostly within residential neighborhoods connecting to adjacent arterial streets. Funds will be requested to develop plans for all missing segments, improved connections to adjacent neighborhoods, and trail crossings at arterial streets. A total of \$375,000 in CMAQ funding will be requested as a part of this \$425,000 design project.
- **Dynamic Traveler Alert Message Boards:** Dynamic Message Signs (DMS) serve the purpose of alerting the traveling public to incidents and other traffic related issues, so that alternative routes may be taken. The City will request CMAQ funding for DMS to be placed on City streets approaching the freeways. A total of \$398,000 in funding for three signs will be requested as a part of this \$450,000 project.

Other projects that may become evident during the analysis and grant preparation process will be submitted to the RCTC for funding consideration as well.

The total amount of funding requested will be a minimum of \$27.8 million.

ALTERNATIVES

1. Approve and authorize the recommended actions as presented in this Staff Report. *This alternative will allow the City to submit applications for the RCTC Multi-funding Call for Projects and potentially receive funding for several key infrastructure projects.*
2. Do not approve and authorize the recommended actions as presented in this Staff Report. *This alternative will prohibit the City from submitting applications for the RCTC Multi-funding Call for Projects.*

FISCAL IMPACT

Applications for the RCTC Multi-funding Call for Projects require a matching fund commitment ranging from 11.47% to 20% from the agency submitting the application (amount dependent upon the type of funding). If projects are selected for the RCTC Multi-funding Call for Projects Program, City staff will bring those selected projects back

to City Council to accept the RCTC grants and appropriate funds. The source of the matching funding would come from available Gas Tax (Fund 2000), Measure A (Fund 2001), DIF Traffic Signals (Fund 2902), DIF Interchange (Fund 2911), TUMF Capital Project funds (Fund 3003), or any other available transportation funding sources. These funds may be used only to implement transportation related programs. There is no impact to the General Fund with this action.

CITY COUNCIL GOALS

PUBLIC SAFETY:

Provide a safe and secure environment for people and property in the community, control the number and severity of fire and hazardous material incidents, and provide protection for citizens who live, work and visit the City of Moreno Valley.

PUBLIC FACILITIES AND CAPITAL PROJECTS:

Ensure that needed public facilities, roadway improvements, and other infrastructure improvements are constructed and maintained.

ATTACHMENTS

Attachment 1: Proposed Resolution

Prepared By
Michael Lloyd, P.E.
Senior Engineer

Department Head Approval
Ahmad R. Ansari, P.E.
Public Works Director/City Engineer

Concurred By
Eric Lewis, P.E., T.E.
City Traffic Engineer

Concurred By
Prem Kumar, P.E.
Deputy Public Works Director/Assistant City Engineer

Council Action	
Approved as requested:	Referred to:
Approved as amended:	For:
Denied:	Continued until:
Other:	Hearing set for:

RESOLUTION NO. 2013-65

A RESOLUTION OF THE CITY COUNCIL OF THE CITY OF MORENO VALLEY, CALIFORNIA, AUTHORIZING THE SUBMITTAL OF APPLICATIONS FOR THE RCTC MULTI-FUNDING CALL FOR PROJECTS AND MATCHING FUND COMMITMENT

WHEREAS, the Riverside County Transportation Commission (RCTC) announced the 2013 Multi-funding Call for Projects seeking candidate projects for a variety of transportation related funds; and

WHEREAS, the City of Moreno Valley has many unfunded projects that may qualify for the RCTC funds; and

WHEREAS, the City of Moreno Valley desires to submit applications for funding from the RCTC 2013 Multi-funding Call for Projects;

NOW, THEREFORE, THE CITY COUNCIL OF THE CITY OF MORENO VALLEY, CALIFORNIA, DOES HEREBY RESOLVE AS FOLLOWS: It does hereby authorize the City Manager to submit applications for the RCTC 2013 Multi-funding Call for Projects and commit to provide the necessary matching funds from available transportation related funds, if projects are selected by the RCTC for funding.

APPROVED AND ADOPTED this 27th day of August, 2013.

Mayor of the City of Moreno Valley

ATTEST:

City Clerk

APPROVED AS TO FORM:

City Attorney

1
Resolution No. 2013-65
Date Adopted: August 27, 2013

RESOLUTION JURAT

STATE OF CALIFORNIA)
COUNTY OF RIVERSIDE) ss.
CITY OF MORENO VALLEY)

I, Jane Halstead, City Clerk of the City of Moreno Valley, California, do hereby certify that Resolution No. 2013-65 was duly and regularly adopted by the City Council of the City of Moreno Valley at a regular meeting thereof held on the 27th day of August, 2013 by the following vote:

AYES:

NOES:

ABSENT:

ABSTAIN:

(Council Members, Mayor Pro Tem and Mayor)

CITY CLERK

(SEAL)

Resolution No. 2013-65²
Date Adopted: August 27, 2013

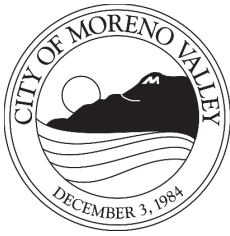

APPROVALS	
BUDGET OFFICER	<i>me</i>
CITY ATTORNEY	<i>SMB</i>
CITY MANAGER	<i>d</i>

Report to City Council

TO: Mayor and City Council

FROM: Ahmad R. Ansari, P.E., Public Works Director/City Engineer

AGENDA DATE: August 27, 2013

TITLE: AWARD THE PURCHASE OF EMERGENCY VEHICLE PRE-EMPTION EQUIPMENT TO GLOBAL TRAFFIC TECHNOLOGIES FOR RETROFITTING 117 EXISTING SIGNALIZED INTERSECTIONS—PROJECT NO. 808 0010 70 76

RECOMMENDED ACTION

Recommendations:

1. Award the purchase of Emergency Vehicle Pre-emption systems for Project No. 808 0010 70 76 to Global Traffic Technologies.
2. Authorize the Purchasing & Facilities Division Manager to execute a Purchase Order to Global Traffic Technologies, in the amount of \$319,062.39 (\$282,356.10 for the bid amount, plus sales tax and 5% contingency) - Account No. 3302-70-76-80008-660310).

BACKGROUND

An Emergency Vehicle Pre-emption (EVP) system allows for priority treatment of emergency vehicles, such as fire trucks and ambulances, at traffic signals. Emergency vehicles are provided with strobe lights which flash light patterns that can be detected by the EVP system. Upon receipt of the appropriate strobe light signal, the traffic signal is programmed to terminate conflicting traffic movements and display a green light for the approaching emergency vehicle. The EVP system's primary benefits are a reduction in response time, of between 14% and 23%, and an improvement in safety since emergency vehicles would normally enter intersections on a green light instead of on a red light.

On March 27, 2007, the City Council authorized Resolution No. 2007-32 requiring the installation of EVP equipment for all future traffic signals. At the time, the City had successfully retrofitted 19 signalized intersections with pre-emption equipment. Subsequently, the City has installed EVP systems at approximately 25 newly signalized intersections.

In 2008, the City successfully applied for Highway Safety Improvement Program (HSIP) funds for the deployment of Emergency Vehicle Pre-emption equipment at 117 existing signalized intersections. Although the City has more than 117 intersections in need of retrofit, staff estimated this to be the maximum number that could be retrofitted under the maximum HSIP grant. The City was awarded the maximum HSIP grant amount of \$1,000,000.

On June 8, 2010, the City Council ratified an agreement with the California Department of Transportation to commence preliminary engineering for this project.

Caltrans environmental staff has declared this project to be categorically excluded from federal environmental review under the National Environmental Policy Act (NEPA), and City planning staff have concurred with the finding and declared the project to be categorically exempt from the California Environmental Quality Act (CEQA).

On November 27, 2012, the City Council rejected all bids for procurement and installation of emergency vehicle pre-emption equipment based on staff's recommendation. The rejection was required due to concerns about the product proposed by the low bidder which were unable to be addressed during the bid evaluation period.

DISCUSSION

Since the last Council activity on this project, staff has performed extensive research, testing, and systems engineering to specify minimum requirements for an EVP system which meets the City's needs while being open to multiple vendors. The procurement documents were drafted based on the new system requirements.

In contrast to the previous advertisement, the current award is for equipment procurement only. It is staff's opinion that a two-step process consisting of procurement, followed by construction, would be the best path to successful completion of the project. Staff is prepared to advertise for construction of the project upon approval of the equipment procurement. All applicable local, state, and federal requirements have been met for this procurement, and will be met for the advertising and award of the construction contract.

A new systems engineering report and concept of operations was prepared by in-house staff. This document was routed to prospective bidders to confirm that multiple bidders would be able to satisfy the requirements. The procurement documents were then completed in May 2013 by in-house staff. The engineer's estimate for the procurement

was \$395,000, which was based on prices provided to another public agency in a competitive procurement process that occurred earlier this year.

Formal bidding procedures have been followed in conformance with the Public Contract Code. The project was also advertised twice in the Press-Enterprise. The Clerk opened bids at 3:00 p.m., on June 18, 2013, for the subject project. The three (3) valid bids received were as follows:

<u>BIDDERS</u>	<u>Bid Amount</u>
1. Global Traffic Technologies (GTT)	\$282,356.10
2. KM Enterprises, Inc.	non-responsive
3. Southwest Traffic Systems	non-responsive

This bid required testing of product prior to award, since the City previously went out to bid on this project on November 27, 2012 and was unable to proceed with the award of contract due to concerns with the proposed equipment.

KM Enterprises, Inc. acknowledged receipt of City correspondence requiring testing, but did not follow up to arrange a test. Therefore the bid is non-responsive since the City was unable to ascertain the suitability of the proposed materials.

Southwest Traffic Systems performed testing on July 17, 2013 and was not able to achieve the equipment performance requirements. Southwest Traffic Systems' bid is therefore non-responsive.

Existing GTT systems installed within the City limits were evaluated and meet the required range test. GTT emergency vehicle pre-emption systems have performed at high levels for many years in Moreno Valley.

ALTERNATIVES

1. Approve and authorize the recommended actions as presented in this staff report. *This alternative will be the best path to successful completion of the project for the City.*
2. Do not approve and authorize the recommended actions as presented in this staff report and provide alternate direction to Staff. *This alternative would potentially delay this project.*

FISCAL IMPACT

This project is included in the Fiscal Year 2013/2014 Capital Improvements Project Budget and is funded using the Traffic Signals Development Impact Fee Fund (Fund 3302). These funds can only be used for traffic signal purposes. There is no impact to

the General Fund. Upon completion of the project, the City will be reimbursed for 90% of the project cost from the Highway Safety Improvement Program.

AVAILABLE FUNDS*

Fiscal Year 2013/2014 Development Impact Fees:
 Account No. 3302-70-76-80008, Project No. 808-0010-70-76-3302 \$910,000

* Fiscal Year 2013/2014 budget estimates do not account for final carryover amounts.

ESTIMATED COSTS (FY13/14 only)

Procurement of EVP System Equipment
 (including 5% contingency and sales tax) **\$319,000**
 Construction (including 15% contingency) \$550,000
 Administration/Project Management** \$35,000
 Total Estimated Cost \$904,000

** Administration/Project Management will be provided by City staff.

ANTICIPATED PROJECT SCHEDULE

Advertise for construction August 2013
 Award construction contract October 2013
 Construction contract duration November 2013-March 2014

CITY COUNCIL GOALS

Advocacy. Develop cooperative intergovernmental relationships and be a forceful advocate of City policies, objectives, and goals to appropriate external governments, agencies and corporations.

Public Safety. Provide a safe and secure environment for people and property in the community, control the number and severity of fire and hazardous material incidents, and provide protection for citizens who live, work and visit the City of Moreno Valley.

Public Facilities and Capital Projects. Ensure that needed public facilities, roadway improvements, and other infrastructure improvements are constructed and maintained.

Positive Environment. Create a positive environment for the development of Moreno Valley's future.

Prepared By:
John Kerenyi
Senior Engineer, P.E.

Department Head Approval:
Ahmad R. Ansari, P.E.
Public Works Director/City Engineer

Concurred By:
Eric Lewis, P.E., T.E.
Transportation Division Manager/City Traffic Engineer

Concurred By:
Rix Skonberg
Purchasing and Facilities Division Manager

Council Action	
Approved as requested:	Referred to:
Approved as amended:	For:
Denied:	Continued until:
Other:	Hearing set for:

This page intentionally left blank.

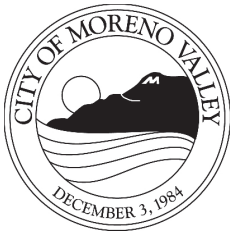

APPROVALS	
BUDGET OFFICER	<i>me</i>
CITY ATTORNEY	<i>SMB</i>
CITY MANAGER	<i>d</i>

Report to City Council

TO: Mayor and City Council

FROM: Richard Teichert, Chief Financial Officer

AGENDA DATE: August 27, 2013

TITLE: APPROVAL OF PAYMENT REGISTER FOR MAY, 2013

RECOMMENDED ACTION

Recommendation:

1. Adopt Resolution No. 2013-66 approving the Payment Register for the month of May, 2013 in the amount of \$12,527,069.50.

DISCUSSION

To facilitate Council's review, the Payment Register lists in alphabetical order all checks in the amount of \$25,000 or greater, followed by a listing in alphabetical order of all checks less than \$25,000. The Payment Register also includes wire transfers, thus eliminating the need for a separate wire transfer register, as well as the fiscal year-to-date (FYTD) amount paid to each vendor.

FISCAL IMPACT

The disbursements itemized in the attached Payment Register are reflected in the FY 2012-13 budget. Therefore, there is no fiscal impact other than the expenditure of budgeted funds.

ATTACHMENTS

Attachment 1: Proposed Resolution

Attachment 2: Payment Register for Month of May, 2013

Prepared By:
Dena Heald
Financial Operations Division Manager

Department Head Approval:
Richard Teichert
Chief Financial Officer

Council Action	
Approved as requested:	Referred to:
Approved as amended:	For:
Denied:	Continued until:
Other:	Hearing set for:

RESOLUTION NO. 2013-66

A RESOLUTION OF THE CITY COUNCIL OF THE CITY OF MORENO VALLEY, CALIFORNIA, APPROVING THE PAYMENT REGISTER FOR THE MONTH OF MAY, 2013

WHEREAS, the Financial & Management Services Department has prepared and provided the Payment Register for the period May 1, 2013 through May 31, 2013, for review and approval by the City Council of the City of Moreno Valley; and

WHEREAS, it is in the best interest of the City that the referenced Payment Register be approved.

NOW, THEREFORE, IT IS HEREBY RESOLVED BY THE CITY COUNCIL OF THE CITY OF MORENO VALLEY, CALIFORNIA, that the Payment Register for the period May 1, 2013 through May 31, 2013, in the total amount of \$12,527,069.50 is approved.

APPROVED AND ADOPTED this 27th day of August, 2013.

Mayor

ATTEST:

City Clerk

APPROVED AS TO FORM:

City Attorney

1
Resolution No. 2013-66
Date Adopted: August 27, 2013

RESOLUTION JURAT

STATE OF CALIFORNIA)
COUNTY OF RIVERSIDE) ss.
CITY OF MORENO VALLEY)

I, Jane Halstead, City Clerk of the City of Moreno Valley, California, do hereby certify that Resolution No. 2013-66 was duly and regularly adopted by the City Council of the City of Moreno Valley at a regular meeting thereof held on the 27th day of August, 2013 by the following vote:

AYES:

NOES:

ABSENT:

ABSTAIN:

CITY CLERK

Resolution No. 2013-66²
Date Adopted: August 27, 2013



**City of Moreno Valley
Payment Register
For Period 5/1/2013 through 5/31/2013**

CHECKS IN THE AMOUNT OF \$25,000 OR GREATER

<u>Vendor Name</u>	<u>Check/EFT Number</u>	<u>Payment Date</u>	<u>Inv Number</u>	<u>Invoice Description</u>	<u>Payment Amount</u>
APIAN ESCROW COMPANY	9354	05/07/2013	W130504	ACQUISITION COSTS & ESCOW FEES/NSP3 PROGRAM-22862 ADRIENNE AVE	\$187,076.97
Remit to: RIVERSIDE, CA					
AVRIO GROUP SURVEILLANCE SOLUTIONS, LLC	9366	05/20/2013	2013-1424	CITYWIDE CAMERA SURVEILLANCE PROJECT-MILESTONE 3	\$180,000.00
Remit to: BUFFALO GROVE, IL					
BANC OF AMERICA PUBLIC CAPITAL CORP	9351	05/01/2013	W130502/R15159	DEBT SVC-2011 PRIV PLCMT REF 1997 LRB-INT EXP	\$55,501.10
Remit to: ATLANTA, GA					
BANC OF AMERICA PUBLIC CAPITAL CORP	9352	05/01/2013	W130503/R15160	DEBT SVC-2011 PRIV PLCMT REF 1997 VAR COPS-INT EXP	\$43,391.20
Remit to: ATLANTA, GA					
COMPU COM	217270	05/20/2013	61777507	MICROSOFT ANNUAL LICENSING	\$117,341.56
Remit to: DALLAS, TX					
COUNTY OF RIVERSIDE SHERIFF	9198	05/06/2013	SH0000021173	CONTRACT LAW ENFORCEMENT BILLING #9 (2/7/13-3/6/13)	\$2,970,860.74
Remit to: RIVERSIDE, CA					
DMC DESIGN GROUP, INC	9201	05/06/2013	2013-040	CONSULTING SERVICES - HEACOCK ST. SOUTH EXTENSION	\$38,109.86
			2013-022	CONSULTING SERVICES - HEACOCK ST. SOUTH EXTENSION	
			2013-034	CONSULTING SERVICES - HEACOCK BRIDGE	
Remit to: CORONA, CA					
E.R. BLOCK PLUMBING & HEATING, INC.	9308	05/13/2013	111997	REPLACE STOLEN BACKFLOW-ZONE E-14	\$26,113.14
Remit to: CORONA, CA					
					FYTD: \$187,076.97
					FYTD: \$180,000.00
					FYTD: \$900,000.00
					FYTD: \$1,124,783.70
					FYTD: \$43,391.20
					FYTD: \$1,124,783.70
					FYTD: \$118,895.30
					FYTD: \$32,634,922.38
					FYTD: \$38,109.86
					FYTD: \$26,113.14
					FYTD: \$148,342.87



**City of Moreno Valley
Payment Register
For Period 5/1/2013 through 5/31/2013**

CHECKS IN THE AMOUNT OF \$25,000 OR GREATER

<u>Vendor Name</u>	<u>Check/EFT Number</u>	<u>Payment Date</u>	<u>Inv Number</u>	<u>Invoice Description</u>	<u>Payment Amount</u>
E.R. BLOCK PLUMBING & HEATING, INC.	9308	05/13/2013	112059	REPLACE STOLEN BACKFLOW-NPDES T33437	\$26,113.14
			112018	REPLACE STOLEN BACKFLOW-ZONE D T21597	
			112017	REPLACE STOLEN BACKFLOW-ZONE D T20660	
			112016	REPLACE STOLEN BACKFLOW-ZONE D T22276	
			112015	REPLACE STOLEN BACKFLOW-ZONE E-14	
			112014	REPLACE STOLEN BACKFLOW-ZONE D T20525	
			112096	REPLACE STOLEN BACKFLOW-ZONE D T31424	
			111998	REPLACE STOLEN BACKFLOW-ZONE E-14	
			112062	REPLACE STOLEN BACKFLOW-ZONE D T19799	
			111996	REPLACE STOLEN BACKFLOW-NPDES T31269	
			111995	REPLACE STOLEN BACKFLOW-ZONE E-14	
			111977	REPLACE STOLEN BACKFLOW-ZONE D T20404	
			111976	REPLACE STOLEN BACKFLOW-ZONE D T30967	
			111975	REPLACE STOLEN BACKFLOW-ZONE D T21113	
			111698	INSTALL BACKFLOW REPAIR KIT-ZONE D T13576,19080,19081	
			111696	INSTALL BACKFLOW REPAIR KIT-NPDES T33437	
			111697	INSTALL BACKFLOW REPAIR KIT-ZONE M	
			111999	REPLACE STOLEN BACKFLOW-ZONE D T31591	
			112019	REPLACE STOLEN BACKFLOW-ZONE D T22277	
Remit to: RIVERSIDE, CA					FYTD: \$74,276.86
EASTERN MUNICIPAL WATER DISTRICT					\$52,202.53
Remit to: PERRIS, CA					FYTD: \$1,357,341.38



**City of Moreno Valley
Payment Register
For Period 5/1/2013 through 5/31/2013**

CHECKS IN THE AMOUNT OF \$25,000 OR GREATER

<u>Vendor Name</u>	<u>Check/EFT Number</u>	<u>Payment Date</u>	<u>Inv Number</u>	<u>Invoice Description</u>	<u>Payment Amount</u>
EASTERN MUNICIPAL WATER DISTRICT	217362	05/28/2013	APR-13 5/28/13	WATER CHARGES	\$32,220.31
Remit to: PERRIS, CA					FYTD: \$1,357,341.38
EMPLOYMENT DEVELOPMENT DEPARTMENT	9356	05/03/2013	2013-00000057	CA TAX - STATE TAX WITHHOLDING*	\$31,350.97
Remit to: WEST SACRAMENTO, CA					FYTD: \$940,832.72
EMPLOYMENT DEVELOPMENT DEPARTMENT	9400	05/17/2013	2013-00000072	CA TAX - STATE TAX WITHHOLDING*	\$31,255.18
Remit to: WEST SACRAMENTO, CA					FYTD: \$940,832.72
EMPLOYMENT DEVELOPMENT DEPARTMENT	9467	05/31/2013	2013-00000099	CA TAX - STATE TAX WITHHOLDING*	\$32,123.63
Remit to: WEST SACRAMENTO, CA					FYTD: \$940,832.72
ENCO UTILITY SERVICES MORENO VALLEY LLC	9423	05/28/2013	0405-1-168R	DISTRIBUTION CHARGES 1/4/13-2/1/13	\$187,135.45
			40-284-02	WORK AUTHORIZATION #40-284	
			40-286-03	WORK AUTHORIZATION #40-286	
			40-221-14	WORK AUTHORIZATION #40-221	
			40-268B-04	WORK AUTHORIZATION #40-268B	
			40-287-01	WORK AUTHORIZATION #40-287	
			40-243A-11	WORK AUTHORIZATION #40-243A-11	
			40-243B-10	WORK AUTHORIZATION #40-243B	
			0406-Temp MF-086	ELECTRIC METER CHARGES (4 METERS)	
			0405-MTS1-SP096	ELECTRIC METER CHARGES (11 METERS)	
			0402-MF-01450A	SOLAR METER INSTALLATION-26186 UNBRIDLED CIR	



**City of Moreno Valley
Payment Register
For Period 5/1/2013 through 5/31/2013**

CHECKS IN THE AMOUNT OF \$25,000 OR GREATER

<u>Vendor Name</u>	<u>Check/EFT Number</u>	<u>Payment Date</u>	<u>Inv Number</u>	<u>Invoice Description</u>	<u>Payment Amount</u>
ENCO UTILITY SERVICES MORENO VALLEY LLC	9423	05/28/2013	0402-MF-01448A	SOLAR METER INSTALLATION-27162 BARK LN	\$187,135.45
			0402-MF-01446A	SOLAR METER INSTALLATION-13806 CLARISSA CT,13315 WEXFORD AV	
			40-273A-07	WORK AUTHORIZATION #40-273A	
			40-247B-06	WORK AUTHORIZATION #40-247B	
			40-279-05	WORK AUTHORIZATION #40-279	
			40-257B-02	WORK AUTHORIZATION #40-257B	
			40-268A-07	WORK AUTHORIZATION #40-268A	
			40-272-08	WORK AUTHORIZATION #40-272	
Remit to: ANAHEIM, CA					FYTD: \$2,347,752.28
FALCON ENGINEERING SERVICES, INC.	9397	05/20/2013	2012-10-A	PROFESSIONAL ENGINEERING SERVICES - SR-60/MB PH I	\$260,116.72
Remit to: CORONA, CA					FYTD: \$1,123,662.39
GLOBAL POWER GROUP, INC.	9427	05/28/2013	28620	CONSTRUCTION CONTRACT - EOC GENERATOR	\$52,088.26
Remit to: LAKESIDE, CA					FYTD: \$315,484.92
GOLDEN STATE CONSTRUCTORS, INC	217144	05/06/2013	442013	SETTLEMENT PAYMENT	\$30,000.00
Remit to: ORANGE, CA					FYTD: \$196,652.00
HILLCREST CONTRACTING, INC	9428	05/28/2013	PB 22279	CONSTRUCTION CONTRACT - PERRIS BLVD WIDENING	\$858,928.54
Remit to: CORONA, CA					FYTD: \$2,733,577.29



**City of Moreno Valley
Payment Register
For Period 5/1/2013 through 5/31/2013**

CHECKS IN THE AMOUNT OF \$25,000 OR GREATER

<u>Vendor Name</u>	<u>Check/EFT Number</u>	<u>Payment Date</u>	<u>Inv Number</u>	<u>Invoice Description</u>	<u>Payment Amount</u>
INTERNAL REVENUE SERVICE CENTER	9357	05/03/2013	2013-00000066	FED TAX - FEDERAL TAX WITHHOLDING*	\$112,058.46
Remit to: OGDEN, UT					<u>FYTD:</u> \$508,592.52
INTERNAL REVENUE SERVICE CENTER	9563	05/17/2013	2013-00000071	FED TAX - FEDERAL TAX WITHHOLDING*	\$124,921.94
Remit to: OGDEN, UT					<u>FYTD:</u> \$508,592.52
MORENO VALLEY UTILITY	217283	05/20/2013	MAY-13 5/20/13	ELECTRICITY	\$56,158.76
Remit to: HEMET, CA					<u>FYTD:</u> \$718,121.58
NATIONWIDE RETIREMENT SOLUTIONS CP	9297	05/03/2013	2013-00000070	8010 - DEF COMP 457 - NATIONWIDE*	\$26,652.04
Remit to: COLUMBUS, OH					<u>FYTD:</u> \$675,276.51
NATIONWIDE RETIREMENT SOLUTIONS CP	9405	05/16/2013	2013-00000088	8010 - DEF COMP 457 - NATIONWIDE*	\$62,804.40
Remit to: COLUMBUS, OH					<u>FYTD:</u> \$675,276.51
PARSONS TRANSPORTATION GROUP, INC.	9441	05/28/2013	1305A861	PROFESSIONAL ENGINEERING SERVICES - SR-60/NASON OC (FINAL DESIGN)	\$107,534.45
			1305A860	PROFESSIONAL ENGINEERING SERVICES - SR-60/MB PH I	
			1305A205	CONSTRUCTION SUPPORT - SR-60/MB PH I	
			1304A098-A	CONSTRUCTION SUPPORT - SR-60/NASON OC	
Remit to: IRVINE, CA					<u>FYTD:</u> \$1,152,648.22
PERS HEALTH INSURANCE	9353	05/09/2013	W130501	EMPLOYEE HEALTH INSURANCE	\$205,507.80
Remit to: SACRAMENTO, CA					<u>FYTD:</u> \$2,204,863.56



**City of Moreno Valley
Payment Register
For Period 5/1/2013 through 5/31/2013**

CHECKS IN THE AMOUNT OF \$25,000 OR GREATER

<u>Vendor Name</u>	<u>Check/EFT Number</u>	<u>Payment Date</u>	<u>Inv Number</u>	<u>Invoice Description</u>	<u>Payment Amount</u>
PERS RETIREMENT	9406	05/10/2013	P130426	PERS RETIREMENT DEPOSIT - CLASSIC	\$219,390.21
Remit to: SACRAMENTO, CA					<u>FYTD:</u> \$5,596,057.52
PERS RETIREMENT	9564	05/24/2013	P130510	MISCELLANEOUS SERVICES	\$219,277.33
Remit to: SACRAMENTO, CA					<u>FYTD:</u> \$5,596,057.52
PROACTIVE ENGINEERING CONSULTANTS, INC.	9215	05/06/2013	2098	CONSULTING SERVICES - NASON/CACTUS TO FIR	\$205,802.60
			2097	CONSULTING SERVICES - NASON/CACTUS TO FIR	
Remit to: CORONA, CA					<u>FYTD:</u> \$638,985.27
PSOMAS	217381	05/28/2013	88021	CONSULTING SERVICES, CONSTRUCTION SUPPORT - CACTUS/NASON	\$26,227.98
			88507	CONSULTING SERVICES, SURVEY - SR-60/NASON OC	
			88327	CONSULTING SERVICES, CONSTRUCTION SUPPORT - CACTUS/NASON	
Remit to: SANTA ANA, CA					<u>FYTD:</u> \$113,698.41
PTM GENERAL ENGINEERING SERVICES, INC.	217382	05/28/2013	0426131217	CONSTRUCTION CONTRACT - JFK/ LAS BRISIS	\$108,836.74
Remit to: RIVERSIDE, CA					<u>FYTD:</u> \$169,172.51
RASMUSSEN BROTHERS CONSTRUCTION	217384	05/28/2013	MVCH 2FI 1	CONSTRUCTION CONTRACT - CITY HALL 2ND FLOOR	\$102,817.17
Remit to: FALLBROOK, CA					<u>FYTD:</u> \$251,330.57
RBF CONSULTING, INC.	9324	05/13/2013	846741	CONSULTING SVCS-IS/MND FOR ALESSANDRO BLVD CORRIDOR IMPLEMENTAT.	\$37,381.94
			840114	CONSULTING SERVICES - ALESSANDRO MEDIAN	



**City of Moreno Valley
Payment Register
For Period 5/1/2013 through 5/31/2013**

CHECKS IN THE AMOUNT OF \$25,000 OR GREATER

<u>Vendor Name</u>	<u>Check/EFT Number</u>	<u>Payment Date</u>	<u>Inv Number</u>	<u>Invoice Description</u>	<u>Payment Amount</u>
Remit to: IRVINE, CA					
RIVERSIDE CONSTRUCTION COMPANY, INC	9399	05/20/2013	130402	CONSTRUCTION CONTRACT - SR-60/NASON OC	\$1,162,958.03
Remit to: RIVERSIDE, CA					
SEQUEL CONTRACTORS, INC.	217263	05/13/2013	442-1	CONSTRUCTION CONTRACT - ALESSANDRO IMPROVEMENTS	\$239,503.07
Remit to: SANTA FE SPRINGS, CA					
SOUTHERN CALIFORNIA EDISON 1	217107	05/06/2013	7500280653	WDAT CHARGES-IRIS AVE. LOCATION	\$33,204.77
			7500280654	WDAT CHARGES-GRAHAM ST. LOCATION	
			7500280655	WDAT CHARGES-GLOBE ST. LOCATION	
			7500280656	WDAT CHARGES-NANDINA AVE. LOCATION	
			7500280657	WDAT CHARGES-FREDERICK AVE. LOCATION	
			7500280658	WDAT CHARGES-SUBSTATION 115KV INTERCONNECTION	
			7500280784	RELIABILITY SERVICE-DLAP_SCE_SEES_HV	
Remit to: ROSEMEAD, CA					
SOUTHERN CALIFORNIA EDISON 1	217291	05/20/2013	707-6081 APR-13	ELECTRICITY	\$193,199.15
			587-9520 APR-13	ELECTRICITY-FERC CHARGES	
			721-3449 APR-13	IFA CHARGES-SUBSTATION	
			APR-13 5/20/13	ELECTRICITY	
Remit to: ROSEMEAD, CA					
STANDARD INSURANCE CO	9280	05/06/2013	130501a	LIFE & DISABILITY INSURANCE	\$28,227.22
Remit to: PORTLAND, OR					
					\$334,248.95



**City of Moreno Valley
Payment Register
For Period 5/1/2013 through 5/31/2013**

CHECKS IN THE AMOUNT OF \$25,000 OR GREATER

<u>Vendor Name</u>	<u>Check/EFT Number</u>	<u>Payment Date</u>	<u>Inv Number</u>	<u>Invoice Description</u>	<u>Payment Amount</u>
SULLY- MILLER CONTRACTING CO., INC.	217297	05/20/2013	12-SMC	CONSTRUCTION CONTRACT - CACTUS/NASON	\$1,262,683.98
			11-SMC	CONSTRUCTION CONTRACT - CACTUS/NASON	
Remit to: BREA, CA					<u>FYTD:</u> \$18,660,892.70
THINK TOGETHER, INC	9331	05/13/2013	111000-12/13-9	ASES PROGRAM MANAGEMENT SERVICES	\$444,467.51
Remit to: LOS ANGELES, CA					<u>FYTD:</u> \$4,042,235.64
TRANSTECH ENGINEERS, INC.	217201	05/13/2013	13	CONSULTING ENGINEERING SERVICES - CACTUS/NASON	\$51,117.12
Remit to: WALNUT, CA					<u>FYTD:</u> \$499,094.36
U.S. BANK/CALCARDS	9334	05/13/2013	04-29-13	CALCARD PAYMENT FOR CYCLE END 4/29/13	\$194,422.96
Remit to: ST. LOUIS, MO					<u>FYTD:</u> \$1,945,551.28
UNION BANK OF CALIFORNIA	9355	05/08/2013	W130505	SUCCESSOR AGENCY-OTHER FUNDS & ACCTS DUE DILIGENCE REVIEW	\$230,820.00
Remit to: MONTEREY PARK, CA					<u>FYTD:</u> \$230,820.00
VISUAL SYSTEMS GROUP, INC.	217400	05/28/2013	51697	CRESTRON SURVEILLANCE EQUIPMENT	\$67,699.24
			51462	CRESTRON SURVEILLANCE EQUIPMENT	
Remit to: MCLEAN, VA					<u>FYTD:</u> \$67,699.24
WELLS FARGO BANK	9409	05/21/2013	W130506	ACQUISITION COSTS & ESCOW FEES/NSP3 PROGRAM-11972 SUGAR CREEK CT	\$119,255.51
Remit to: SAN FRANCISCO, CA					<u>FYTD:</u> \$819,487.56
WELLS FARGO BANK	9561	05/24/2013	W130507	ACQUISITION COSTS & ESCOW FEES/NSP3 PROGRAM-23680 MARK TWAIN ST	\$143,604.00



City of Moreno Valley
Payment Register
 For Period 5/1/2013 through 5/31/2013

CHECKS IN THE AMOUNT OF \$25,000 OR GREATER

<u>Vendor Name</u>	<u>Check/EFT Number</u>	<u>Payment Date</u>	<u>Inv Number</u>	<u>Invoice Description</u>	<u>Payment Amount</u>
Remit to: SAN FRANCISCO, CA				<u>FYTD:</u>	\$819,487.56
WELLS FARGO BANK	9562	05/24/2013	W130508	ACQUISITION COSTS & ESCOW FEES/NSP3 PROGRAM-12669 GORHAM ST	\$145,569.60
Remit to: SAN FRANCISCO, CA				<u>FYTD:</u>	\$819,487.56
WEST COAST ARBORISTS, INC.	9394	05/20/2013	86081-A	TREE TRIMMING & REMOVAL SERVICES-ZONES E-1, E-2, & E-16	\$29,645.00
			86606-A	TREE TRIMMING & REMOVAL SERVICES-ZONES DSG-1, DSG-2, E-8 & E-12	
			86501-A	TREE TRIMMING & REMOVAL SERVICES-ZONES E-1, E-2, & E-7	
Remit to: ANAHEIM, CA				<u>FYTD:</u>	\$117,390.00
WRCOG WESTERN RIVERSIDE CO. OF GOVT'S.	217117	05/06/2013	APR-13 TUMF	TUMF FEES COLLECTED FOR 4/1-4/30/13	\$28,784.56
Remit to: RIVERSIDE, CA				<u>FYTD:</u>	\$1,345,525.49

TOTAL AMOUNTS OF \$25,000 OR GREATER **\$11,176,349.70**



City of Moreno Valley
Payment Register
 For Period 5/1/2013 through 5/31/2013

CHECKS UNDER \$25,000

<u>Vendor Name</u>	<u>Check/EFT Number</u>	<u>Payment Date</u>	<u>Inv Number</u>	<u>Invoice Description</u>	<u>Payment Amount</u>
AARON KENT	217146	05/06/2013	5/6-5/10/13	TRAVEL PER DIEM-MGMT & SUPERVISION OF DETECTIVE UNITS TRAINING	\$200.00
Remit to: MORENO VALLEY, CA					
ABILITY COUNTS, INC	217352	05/28/2013	ACI9964	LANDSCAPE MAINT-VRS LOCATIONS-PARK MAINT	\$2,065.00
Remit to: CORONA, CA					
ACCURATE COLORS, INC	217422	05/28/2013	BL#12992-YR2013	REFUND OF OVERPAYMENT FOR BL#12992	\$92.00
Remit to: RANCHO CUCAMONGA, CA					
ACTION DOOR REPAIR CORP.	9363	05/20/2013	85696	DOOR DISTANCE ADJUSTMENT-PSB GATE#7	\$875.25
			85761	INSTALL ONE IDLER ASSEMBLY-PBS GATE#4	
Remit to: ORLANDO, FL					
ACTION DOOR REPAIR CORP.	9412	05/28/2013	85831	REPAIR REAR BAY DOORS 2 & 3-FIRE STN 58	\$4,150.97
			85907	REDESIGN DOUBLE EXTERIOR DOORS-ANIMAL SVCS	
Remit to: ORLANDO, FL					
ACTIVE NETWORK, INC., THE	9298	05/13/2013	1006381	PROFESSIONAL SVCS-LOGOS PROJECT	\$9,527.33
			11044354	ELECTRONIC DEPOSIT CHECK SCANNER-1 UNIT	
Remit to: SAN DIEGO, CA					
ACTIVE NETWORK, INC., THE	9413	05/28/2013	1006657	PROFESSIONAL SVCS-SETUP OF CHECK SCANNERS	\$380.00
Remit to: SAN DIEGO, CA					
ADAMS, MARK L.	9225	05/06/2013	130501	RETIREE MEDICAL MAY '13	\$318.73



**City of Moreno Valley
Payment Register
For Period 5/1/2013 through 5/31/2013**

CHECKS UNDER \$25,000

<u>Vendor Name</u>	<u>Check/EFT Number</u>	<u>Payment Date</u>	<u>Inv Number</u>	<u>Invoice Description</u>	<u>Payment Amount</u>
Remit to: REDLANDS, CA				<u>FYTD:</u>	\$3,187.30
Addus Health Care	217212	05/13/2013	495428	DEPOSIT REFUND CRC	\$500.00
Remit to: RIVERSIDE, CA				<u>FYTD:</u>	\$500.00
ADLERHORST INTERNATIONAL INC.	9192	05/06/2013	17356	TRAINING AGITATOR-10/11-10/12/12-D. SALUDES	\$300.00
			17355	TRAINING AGITATOR-10/11-10/12/12-R. BENART	
Remit to: RIVERSIDE, CA				<u>FYTD:</u>	\$6,422.89
ADLERHORST INTERNATIONAL INC.	9414	05/28/2013	18346	DOG FOOD FOR PATROL K-9 IVAN	\$429.14
			18325	MONTHLY K-9 TRAINING-OZZIE-APR13	
			18324	MONTHLY K-9 TRAINING-DUKE-APR13	
Remit to: RIVERSIDE, CA				<u>FYTD:</u>	\$6,422.89
ADMINSURE	217176	05/13/2013	6350	WORKERS' COMP CLAIMS ADMIN.-MAY13	\$2,600.00
Remit to: DIAMOND BAR, CA				<u>FYTD:</u>	\$31,200.00
ADVANCE REFRIGERATION & ICE SYSTEMS, INC	9299	05/13/2013	3284-36518	REMOVE/INSTALL ICE MACHINE NEW DISPENSER	\$522.00
Remit to: RIVERSIDE, CA				<u>FYTD:</u>	\$10,533.00
ADVANCED ELECTRIC	217177	05/13/2013	10720	REPLACED RECEPTACLE-COPIER-FINANCE ANNEX	\$130.50
			10705	DOOR BELL REPAIRED-FIRE STN 58	
Remit to: RIVERSIDE, CA				<u>FYTD:</u>	\$32,713.98
ADVANCED ELECTRIC	217265	05/20/2013	10706	ELECTRICAL SVC CALL-DOOR BELL-FIRE STN 65	\$62.00



**City of Moreno Valley
Payment Register
For Period 5/1/2013 through 5/31/2013**

CHECKS UNDER \$25,000

<u>Vendor Name</u>	<u>Check/EFT Number</u>	<u>Payment Date</u>	<u>Inv Number</u>	<u>Invoice Description</u>	<u>Payment Amount</u>
Remit to: RIVERSIDE, CA				<u>FYTD:</u>	\$32,713.98
ADVANCO FIRE PROTECTION	217449	05/28/2013	29655-1	FIRE SPRINKLR 5-YR CERTIFICATN-FIRE STN 2,6,48,91	\$1,580.00
Remit to: ONTARIO, CA				<u>FYTD:</u>	\$1,580.00
AEI-CASC ENGINEERING	9364	05/20/2013	0029301	PLAN CHECK SVCS-PWQMP	\$378.00
Remit to: COLTON, CA				<u>FYTD:</u>	\$21,874.00
AEROTEK, INC.	217178	05/13/2013	OP04010985	TEMPORARY STAFFING-ERP-PAYROLL	\$3,507.38
			OP04026242	TEMPORARY STAFFING-ERP-PAYROLL	
			OP03966324-A	TEMPORARY STAFFING INV BAL DUE-ERP-PAYROLL	
Remit to: CHICAGO, IL				<u>FYTD:</u>	\$26,642.34
AEROTEK, INC.	217266	05/20/2013	OP04040735	TEMPORARY STAFFING-ERP-PAYROLL	\$1,623.48
Remit to: CHICAGO, IL				<u>FYTD:</u>	\$26,642.34
ALBERT A. WEBB ASSOCIATES	217076	05/06/2013	130229	CONSULTING SERVICES - EDGEMONT WATER MASTER PLAN	\$13,991.75
			130645	CONSULTING SERVICES - EDGEMONT WATER MASTER PLAN	
Remit to: RIVERSIDE, CA				<u>FYTD:</u>	\$31,020.90
ALLIANZ LIFE INSURANCE CO	217267	05/20/2013	2013-00000090	8794 - ALLIANZ - EMPLOYEE*	\$75.00
Remit to: PITTSBURGH, PA				<u>FYTD:</u>	\$825.00
AMAZING DISCOUNT STORE	217213	05/13/2013	BL#11545-YR2013	REFUND OF OVERPAYMENT FOR B/L #11545	\$61.21
Remit to: MONTCLAIR, CA				<u>FYTD:</u>	\$61.21
AMBER FRANSIK	217415	05/28/2013	6/4-6/6/13	TRAVEL PER DIEM FOR ADVANCED CPTE TRAINING	\$150.00



**City of Moreno Valley
Payment Register
For Period 5/1/2013 through 5/31/2013**

CHECKS UNDER \$25,000

<u>Vendor Name</u>	<u>Check/EFT Number</u>	<u>Payment Date</u>	<u>Inv Number</u>	<u>Invoice Description</u>	<u>Payment Amount</u>
Remit to: MORENO VALLEY, CA					<u>FYTD:</u> \$150.00
Amber White	217254	05/13/2013	495995	REFUND CONTRACT CLASS	\$47.00
Remit to: MORENO VALLEY, CA					<u>FYTD:</u> \$47.00
AMERICAN ASPHALT SOUTH, INC	217351	05/20/2013	2013-RETENTION	CONSTRUCTION CONTRACT - SUNNYMEAD RANCH PKWY SLURRY SEAL	\$4,123.75
Remit to: FONTANA, CA					<u>FYTD:</u> \$82,475.00
AMTECH ELEVATOR SERVICES	217179	05/13/2013	DVB05044513	ELEVATOR MAINT/REPAIR-MAY 2013-CITY HALL	\$224.92
Remit to: PASADENA, CA					<u>FYTD:</u> \$4,569.56
AMTECH ELEVATOR SERVICES	217268	05/20/2013	DVB65903113	ELEVATOR MAINT/REPAIR JAN-JUN 2013 - CRC	\$421.80
Remit to: PASADENA, CA					<u>FYTD:</u> \$4,569.56
AMTECH ELEVATOR SERVICES	217353	05/28/2013	DVB28069001	ELEVATOR MAINT/REPAIR-CITY HALL	\$723.00
Remit to: PASADENA, CA					<u>FYTD:</u> \$4,569.56
ANA TSAI	217171	05/06/2013	PK13-0011	REFUND-WITHDRAWAL OF LANDSCAPE PLAN CHECK	\$173.00
Remit to: ROWLAND HEIGHTS, CA					<u>FYTD:</u> \$173.00
ANDREA N. HARMON	217342	05/20/2013	MV3130306025	REFUND-CITATION OVERPAYMENT	\$48.00
Remit to: SUN CITY, CA					<u>FYTD:</u> \$48.00
ANDREA THOMAS	217446	05/28/2013	1041332	REFUND FOR TOWNGATE DEPOSIT	\$200.00



**City of Moreno Valley
Payment Register
For Period 5/1/2013 through 5/31/2013**

CHECKS UNDER \$25,000

<u>Vendor Name</u>	<u>Check/EFT Number</u>	<u>Payment Date</u>	<u>Inv Number</u>	<u>Invoice Description</u>	<u>Payment Amount</u>
Remit to: MORENO VALLEY, CA				FYTD:	\$200.00
ANIMAL PEST MANAGEMENT SERVICES, INC.	9415	05/28/2013	110048	PEST CONTROL-CITY PARKS	\$1,725.50
			110051	PEST CONTROL-MARCH FIELD CNTR	
			110848	BEE REMOVAL-CFD #1-SHADOW MOUNTAIN PARK	
			110183	PEST CONTROL-GOLF COURSE	
			110049	PEST CONTROL-SCE ESMNT/AQDCT/BIKEWAY	
			110164	PEST CONTROL-CFD #1	
			110050	PEST CONTROL-MARCH BALLFIELDS	
Remit to: CHINO, CA				FYTD:	\$17,180.50
ARCHIVE MANAGEMENT SERVICE	9300	05/13/2013	0204854	OFF-SITE STORAGE OF CITY RECORDS	\$1,447.58
Remit to: KING OF PRUSSIA, PA				FYTD:	\$17,479.59
ARCON STRUCTURAL ENGINEERS, INC	217450	05/28/2013	6584	CONSTRUCTION SUPPORT - CACTUS/NASON	\$4,127.50
Remit to: RANCHO SANTA MARGARITA, C				FYTD:	\$28,650.68
ARM SECURITY, INC	217214	05/13/2013	BL#23995-YR2013	REFUND OF OVERPAYMENT FOR B/L #23995	\$67.11
Remit to: PROVO, UT				FYTD:	\$67.11
ARNETT A. LABAUSA	217161	05/06/2013	7013551-02	SOLAR INCENTIVE REBATE	\$10,894.50
Remit to: MORENO VALLEY, CA				FYTD:	\$10,894.50
ARROWHEAD WATER	9301	05/13/2013	03D0029115201 03D0029115177	WATER PURIFY RNTL UNIT-SENIOR CNTR WATER PURIFY RNTL UNIT-ANIMAL SVCS	\$199.74



**City of Moreno Valley
Payment Register
For Period 5/1/2013 through 5/31/2013**

CHECKS UNDER \$25,000

<u>Vendor Name</u>	<u>Check/EFT Number</u>	<u>Payment Date</u>	<u>Inv Number</u>	<u>Invoice Description</u>	<u>Payment Amount</u>
ARROWHEAD WATER	9301	05/13/2013	03D0029115243	WATER PURIFY RNTL UNIT-TECH SVCS ANNEX	\$199.74
			03D0029115227	WATER PURIFY RNTL UNIT-SDA ANNEX	
			03D0029115300	WATER PURIFY RNTL UNIT-FACILITIES ANNEX	
			03D0029115359	WATER PURIFY RNTL UNIT-CRC	
Remit to: LOUISVILLE, KY					<u>FYTD:</u> \$6,870.11
ARROWHEAD WATER	9365	05/20/2013	03E0032567869	WATER PURIFY RNTL UNIT-ANNEX 1	\$337.92
			03E0032414377	WATER PURIFY RNTL UNIT-PSB	
			03E0029647948	WATER PURIFY RNTL UNIT-FIRE STN 48	
			03E0029647997	WATER PURIFY RNTL UNIT-FIRE STN 58	
			03E0028990919	WATER PURIFY RNTL UNIT-CITY HALL	
			03E0029647971	WATER PURIFY RNTL UNIT-FIRE STN 2	
			03E0029648052	WATER PURIFY RNTL UNIT-FIRE STN 65	
			03E0029115110	WATER PURIFY RNTL UNIT-CITY YARD	
			03E0032389744	WATER PURIFY RNTL UNIT-FIRE STN 99	
			03E0029647914	WATER PURIFY RNTL UNIT-FIRE STN 6	
Remit to: LOUISVILLE, KY					<u>FYTD:</u> \$6,870.11
AUDREY SILVERMAN	217167	05/06/2013	R12-053540	AS REFUND-RAB DEP FR FORFEIT ACCT	\$20.00
Remit to: NEWPORT BEACH, CA					<u>FYTD:</u> \$20.00
AV GRAPHICS, INC.	217258	05/13/2013	46490	PRINTING SVCS-ADMIN CITATIONS-POLICE	\$2,772.04
Remit to: LOS ANGELES, CA					<u>FYTD:</u> \$2,772.04
AXIS APPAREL	9193	05/06/2013	04182013	YOUTH & ADULT UNIFORMS-FLAG FOOTBALL	\$1,644.46



City of Moreno Valley
Payment Register
 For Period 5/1/2013 through 5/31/2013

CHECKS UNDER \$25,000

<u>Vendor Name</u>	<u>Check/EFT Number</u>	<u>Payment Date</u>	<u>Inv Number</u>	<u>Invoice Description</u>	<u>Payment Amount</u>
Remit to: MORENO VALLEY, CA				<u>FYTD:</u>	\$28,209.49
B A ELECTRIC	217314	05/20/2013	BL#23191-YR2013	REFUND OF OVERPAYMENT FOR BL#23191	\$82.23
Remit to: MORENO VALLEY, CA				<u>FYTD:</u>	\$82.23
BACHER, GRACE	217118	05/06/2013	130501	RETIREE MEDICAL MAY '13	\$255.43
Remit to: HEMET, CA				<u>FYTD:</u>	\$2,870.80
BAUTISTA, JOSEPH C.	9226	05/06/2013	130501	RETIREE MEDICAL MAY '13	\$318.73
Remit to: FONTANA, CA				<u>FYTD:</u>	\$3,187.30
BELMUEDES, DEBRA	9227	05/06/2013	130501	RETIREE MEDICAL MAY '13	\$318.73
Remit to: MORENO VALLEY, CA				<u>FYTD:</u>	\$1,593.65
BEMUS LANDSCAPE, INC.	9302	05/13/2013	242913	LANDSCAPE MAINT-SCE/OLD LAKE DR	\$16,978.63
	242916			LANDSCAPE MAINT-INDIAN/FILAREE/FAY BIKE AQDCT	
	242912			LANDSCAPE MAINT-SENIOR CNTR	
	242914			LANDSCAPE MAINT-PATRIOT PARK	
	242926			LANDSCAPE MAINT-TOWNGATE CNTR	
	242919			LANDSCAPE MAINT-VETERANS MEMORIAL	
	242915			LANDSCAPE MAINT-BAY/JFK AQDCT	
	242930			LANDSCAPE MAINT-ANIMAL SVCS	
	242929			LANDSCAPE MAINT-PSB	
	242909			LANDSCAPE MAINT-S AQDCT B	
	242922			LANDSCAPE MAINT-FORMER STARS BLDG	
	242928			LANDSCAPE MAINT-MVU SUBSTN	



**City of Moreno Valley
Payment Register
For Period 5/1/2013 through 5/31/2013**

CHECKS UNDER \$25,000

<u>Vendor Name</u>	<u>Check/EFT Number</u>	<u>Payment Date</u>	<u>Inv Number</u>	<u>Invoice Description</u>	<u>Payment Amount</u>
BEMUS LANDSCAPE, INC.	9302	05/13/2013	242923	LANDSCAPE MAINT-CRC	\$16,978.63
			242910	LANDSCAPE MAINT-N AQDCT	
			242917	LANDSCAPE MAINT-S AQDCT A	
			242931	LANDSCAPE MAINT-CITY HALL	
			242932	LANDSCAPE MAINT-FIRE STNS	
			242911	LANDSCAPE MAINT-PAN AM/AQDCT	
			242920	LANDSCAPE MAINT-ANNEX 1	
			242927	LANDSCAPE MAINT-TOWNGATE BIKE AQDCT	
			242925	LANDSCAPE MAINT-MVU	
			242921	LANDSCAPE MAINT-CITY YARD	
			242924	LANDSCAPE MAINT-LIBRARY	
Remit to: SAN CLEMENTE, CA					FYTD: \$201,170.99
BEN CLYMER'S THE BODY SHOP MV INC	217423	05/28/2013	ACCT #01509	REFUND OVERPAYMENT OF FALSE ALARM	\$41.00
Remit to: MORENO VALLEY, CA					FYTD: \$41.00
BENESYST	9303	05/13/2013	0413285	COBRA ADMIN FEE	\$205.00
Remit to: MINNEAPOLIS, MN					FYTD: \$4,912.92
BENESYST	9304	05/13/2013	0413146	FSA ADMIN COSTS	\$211.64
Remit to: MINNEAPOLIS, MN					FYTD: \$4,912.92
Bertha Rodriguez	217241	05/13/2013	494175	REFUND PICNIC SHELTER LESS 20%	\$64.00
Remit to: MORENO VALLEY, CA					FYTD: \$64.00



**City of Moreno Valley
Payment Register
For Period 5/1/2013 through 5/31/2013**

CHECKS UNDER \$25,000

<u>Vendor Name</u>	<u>Check/EFT Number</u>	<u>Payment Date</u>	<u>Inv Number</u>	<u>Invoice Description</u>	<u>Payment Amount</u>
BEST, BEST & KRIEGER, LLP	9194	05/06/2013	700368	LEGAL SVCS-MATTER#55416.00100	\$7,006.00
			700367	LEGAL SVCS-GENERAL	
Remit to: RIVERSIDE, CA					<u>FYTD:</u> \$24,066.80
BEST, BEST & KRIEGER, LLP	9416	05/28/2013	702562	LEGAL SVCS-COMPTON CASE	\$9,578.30
			702561	LEGAL SVCS-GEN MATTERS	
Remit to: RIVERSIDE, CA					<u>FYTD:</u> \$24,066.80
BESTWAY LAUNDRY SOLUTIONS, INC.	217077	05/06/2013	1260344	COMMERCIAL WASHER REPAIRS	\$128.00
Remit to: CORONA, CA					<u>FYTD:</u> \$486.94
Betty Torrejon	217249	05/13/2013	493560	DROPPED PROGRAM	\$57.60
Remit to: MORENO VALLEY, CA					<u>FYTD:</u> \$57.60
BMW MOTORCYCLES OF RIVERSIDE	217354	05/28/2013	6005495/1	MAINT & REPAIRS-NEW TRAFFIC MOTORCYCLES	\$686.68
			6005492/1	MAINT & REPAIRS-NEW TRAFFIC MOTORCYCLES	
Remit to: RIVERSIDE, CA					<u>FYTD:</u> \$55,726.16
BONNIE KENNEMER	217159	05/06/2013	7011355-03	SOLAR INCENTIVE REBATE	\$14,000.00
Remit to: MORENO VALLEY, CA					<u>FYTD:</u> \$14,000.00
BOX SPRINGS MUTUAL WATER COMPANY	217078	05/06/2013	04242013	WATER USAGE ACCOUNT 721-1 - ZONE E-1	\$108.40
Remit to: MORENO VALLEY, CA					<u>FYTD:</u> \$559.90
BRAUN BLAISING MCLAUGHLIN	217079	05/06/2013	14617	LEGAL SVCS-MVU	\$3,616.86



**City of Moreno Valley
Payment Register
For Period 5/1/2013 through 5/31/2013**

CHECKS UNDER \$25,000

<u>Vendor Name</u>	<u>Check/EFT Number</u>	<u>Payment Date</u>	<u>Inv Number</u>	<u>Invoice Description</u>	<u>Payment Amount</u>
BRAUN BLAISING MCLAUGHLIN	217079	05/06/2013	14618	LEGAL SVCS-STREETLIGHT RATE CASE (CASL)	\$3,616.86
Remit to: SACRAMENTO, CA					
BREITKREUZ, THOMAS F.	217119	05/06/2013	130501	JAN-MAR '13 PD MA '13	\$956.19
Remit to: REDLANDS, CA					
BRODART CO.	9195	05/06/2013	B2771964	MISC BOOKS-LIBRARY	\$2,010.94
			B2735107	MISC BOOKS-LIBRARY	
			B2779172	MISC BOOKS-LIBRARY	
			B2780805	MISC BOOKS-LIBRARY	
			B2782632	MISC BOOKS-LIBRARY	
			B2774161	MISC BOOKS-LIBRARY	
			B2794154	MISC BOOKS-LIBRARY	
			B2802467	MISC BOOKS-LIBRARY	
			B2786377	MISC BOOKS-LIBRARY	
			B2784617	MISC BOOKS-LIBRARY	
Remit to: WILLIAMSPORT, PA					
BUCKINGHAM, STAN	217120	05/06/2013	130501	RETIREE MEDICAL MAY '13	\$318.73
Remit to: TEMECULA, CA					
BY HIS DESIGN, INC	217080	05/06/2013	5483	SPORTS UNIFORMS	\$300.00
Remit to: SAN JACINTO, CA					
C & C GRADING & PAVING, INC	9367	05/20/2013	1630-3	CONSTRUCTION CONTRACT - SIP (KENTLAND, WILSON, KINNY)	\$23,137.15
					FYTD:
					\$22,625.36
					FYTD:
					\$3,187.30
					FYTD:
					\$1,412.03



City of Moreno Valley
Payment Register
 For Period 5/1/2013 through 5/31/2013

CHECKS UNDER \$25,000

<u>Vendor Name</u>	<u>Check/EFT Number</u>	<u>Payment Date</u>	<u>Inv Number</u>	<u>Invoice Description</u>	<u>Payment Amount</u>
Remit to: TEMECULA, CA					<u>FYTD:</u> \$251,842.02
CAIN, GREGORY	9228	05/06/2013	130501	RETIREE MEDICAL MAY '13	\$318.73
Remit to: TAMPA, FL					<u>FYTD:</u> \$3,187.30
CALIFORNIA TRANSCRIPTION, LLC	217081	05/06/2013	1549	TRANSCRIPTION SVCS-PLANNING MTG MINUTES	\$1,444.53
Remit to: MORONGO VALLEY, CA					<u>FYTD:</u> \$2,368.25
CALIFORNIA WATERSHED ENGINEERING CORP.	9417	05/28/2013	13710	PLAN CHECK SVCS-PWQMP	\$970.25
Remit to: FULLERTON, CA					<u>FYTD:</u> \$19,889.25
CANNON, ANA M.	9229	05/06/2013	130501	RETIREE MEDICAL MAY '13	\$318.73
Remit to: HASLET, TX					<u>FYTD:</u> \$3,187.30
Career Care Institute	217219	05/13/2013	494817	DEPOSIT REFUND CRC	\$500.00
Remit to: LANCASTER, CA					<u>FYTD:</u> \$500.00
CARTER, ROSALYN	9230	05/06/2013	130501	FEB '13, PD MAY '13	\$318.73
Remit to: MORENO VALLEY, CA					<u>FYTD:</u> \$1,912.38
CASTANEDA & ASSOCIATES	217355	05/28/2013	INV 2	PROF SVCS-FAIR HOUSING ACTION PLAN	\$8,509.18
Remit to: RIVERSIDE, CA					<u>FYTD:</u> \$18,577.50
CEMEX	217082	05/06/2013	9425883710	PORTLAND CEMENT-MAIN/OP'S	\$2,160.74
			9425821284	CONCRETE-SIDEWALK STEPS-ANNEX 1	
			9425838303	PORTLAND CEMENT-MAIN/OP'S	



**City of Moreno Valley
Payment Register
For Period 5/1/2013 through 5/31/2013**

CHECKS UNDER \$25,000

<u>Vendor Name</u>	<u>Check/EFT Number</u>	<u>Payment Date</u>	<u>Inv Number</u>	<u>Invoice Description</u>	<u>Payment Amount</u>
CEMEX	217082	05/06/2013	9425916173	PORTLAND CEMENT-MAIN/OP'S	\$2,160.74
			9425869147	PORTLAND CEMENT-MAIN/OP'S	
Remit to: PASADENA, CA					
CHANCY, CHIZURU	217140	05/06/2013	APR-2013	INSTRUCTOR SVCS-HAWAIIAN DANCE CLASSES	\$327.60
Remit to: MORENO VALLEY, CA					
CHANCY, CHIZURU	217408	05/28/2013	MAY-2013	INSTRUCTOR SVCS-HAWAIIAN DANCE CLASSES	\$324.60
Remit to: MORENO VALLEY, CA					
CHANDLER ASSET MANAGEMENT, INC	9305	05/13/2013	12505	INVESTMENT MANAGEMENT SVCS-FEB13	\$7,741.00
Remit to: SAN DIEGO, CA					
CHANDLER ASSET MANAGEMENT, INC	9306	05/13/2013	12822	INVESTMENT MANAGEMENT SVCS-APR13	\$15,399.00
			12661	INVESTMENT MANAGEMENT SVCS-MAR13	
Remit to: SAN DIEGO, CA					
CHAPMAN, STEVE	217121	05/06/2013	130501	RETIREE MEDICAL MAY '13	\$318.73
Remit to: REDLANDS, CA					
CHAPPELL, ISAAC	9231	05/06/2013	130501	RETIREE MEDICAL MAY '13	\$318.73
Remit to: MORENO VALLEY, CA					
CHARLES ALM	217407	05/28/2013	321	TOWNGATE PARK CONCERT-JOSHUA TREE BAND-6/14/13	\$1,000.00
Remit to: ORANGE, CA					
					FYTD: \$20,727.67
					FYTD: \$1,984.20
					FYTD: \$1,984.20
					FYTD: \$88,346.00
					FYTD: \$88,346.00
					FYTD: \$3,187.30
					FYTD: \$3,187.30
					FYTD: \$1,000.00
					FYTD: \$1,000.00



**City of Moreno Valley
Payment Register
For Period 5/1/2013 through 5/31/2013**

CHECKS UNDER \$25,000

<u>Vendor Name</u>	<u>Check/EFT Number</u>	<u>Payment Date</u>	<u>Inv Number</u>	<u>Invoice Description</u>	<u>Payment Amount</u>
CHRISTOS E. GANDARA	217338	05/20/2013	MV3130226007	REFUND-CITATION OVERPAYMENT	\$57.50
Remit to: RIALTO, CA					
CINTAS CORPORATION	9196	05/06/2013	150832738	UNIFORM RNTL SVC-CONCRETE MAINT	\$631.22
			150832737	UNIFORM RNTL SVC-ST MAINT	
			150832736	UNIFORM RNTL SVC-DRAIN MAINT	
			150832735	UNIFORM RNTL SVC-ST SWEEPING	
			150832733	UNIFORM RNTL SVC-ST TREE MAINT	
			150832732	UNIFORM RNTL SVC-VEHICLE MAINT	
			150828263	UNIFORM RNTL SVC-CONCRETE MAINT	
			150828256	UNIFORM RNTL SVC-GRAFFITI RMVL	
			150823826	UNIFORM RNTL SVC-VEHICLE MAINT	
			150819292	UNIFORM RNTL SVC-PURCHASING	
			150828257	UNIFORM RNTL SVC-VEHICLE MAINT	
			150823822	UNIFORM RNTL SVC-PURCHASING	
			150823830	UNIFORM RNTL SVC-DRAIN MAINT	
			150828253	UNIFORM RNTL SVC-PURCHASING	
			150832731	UNIFORM RNTL SVC-GRAFFITI RMVL	
			150823832	UNIFORM RNTL SVC-CONCRETE MAINT	
			150832728	UNIFORM RNTL SVC-PURCHASING	
			150823825	UNIFORM RNTL SVC-GRAFFITI RMVL	
			150828262	UNIFORM RNTL SVC-ST MAINT	
			150823829	UNIFORM RNTL SVC-ST SWEEPING	
			150823827	UNIFORM RNTL SVC-ST TREE MAINT	
				FYTD:	\$57.50



City of Moreno Valley
Payment Register
For Period 5/1/2013 through 5/31/2013

CHECKS UNDER \$25,000

<u>Vendor Name</u>	<u>Check/EFT Number</u>	<u>Payment Date</u>	<u>Inv Number</u>	<u>Invoice Description</u>	<u>Payment Amount</u>
CINTAS CORPORATION	9196	05/06/2013	150828261	UNIFORM RNTL SVC-DRAIN MAINT	\$631.22
			150828260	UNIFORM RNTL SVC-ST SWEEPING	
			150828258	UNIFORM RNTL SVC-ST TREE MAINT	
			150823831	UNIFORM RNTL SVC-ST MAINT	
Remit to: ONTARIO, CA					FYTD: \$15,817.09
CINTAS CORPORATION	9307	05/13/2013	150837200	UNIFORM RNTL SVC-PARK MAINT	\$89.70
			150837213	UNIFORM RNTL SVC-GOLF COURSE	
			150837212	UNIFORM RNTL SVC-FACILITIES	
			150837207	UNIFORM RNTL SVC-CFD #1	
Remit to: ONTARIO, CA					FYTD: \$15,817.09
CINTAS CORPORATION	9368	05/20/2013	150837206	UNIFORM RNTL SVC-ST TREE MAINT	\$235.45
			150837204	UNIFORM RNTL SVC-GRAFFITI RMVL	
			150837208	UNIFORM RNTL SVC-ST SWEEPING	
			150837210	UNIFORM RNTL SVC-ST MAINT	
			150837211	UNIFORM RNTL SVC-CONCRETE MAINT	
			150837202	UNIFORM RNTL SVC-TRAFFIC SIGNAL	
			150837203	UNIFORM RNTL SVC-ST SIGNS/STRIPING	
			150837205	UNIFORM RNTL SVC-VEHICLE MAINT	
			150837209	UNIFORM RNTL SVC-DRAIN MAINT	
Remit to: ONTARIO, CA					FYTD: \$15,817.09
CINTAS CORPORATION	9418	05/28/2013	150841721	UNIFORM RNTL SVC-PARK MAINT	\$286.59
			150100648	UNIFORM RNTL SVC-CFD #1	



**City of Moreno Valley
Payment Register
For Period 5/1/2013 through 5/31/2013**

CHECKS UNDER \$25,000

<u>Vendor Name</u>	<u>Check/EFT Number</u>	<u>Payment Date</u>	<u>Inv Number</u>	<u>Invoice Description</u>	<u>Payment Amount</u>
CINTAS CORPORATION	9418	05/28/2013	150846190	UNIFORM RNTL SVC-FACILITIES	\$286.59
			150841728	UNIFORM RNTL SVC-CFD #1	
			150100653	UNIFORM RNTL SVC-FACILITIES	
			150100654	UNIFORM RNTL SVC-GOLF COURSE	
			150100641	UNIFORM RNTL SVC-PARK MAINT	
			150841734	UNIFORM RNTL SVC-GOLF COURSE	
			150841733	UNIFORM RNTL SVC-FACILITIES	
			150846191	UNIFORM RNTL SVC-GOLF COURSE	
			150846185	UNIFORM RNTL SVC-CFD #1	
			150846178	UNIFORM RNTL SVC-PARK MAINT	
Remit to: ONTARIO, CA					FYTD: \$15,817.09
CITY OF MORENO VALLEY VEBA TRUST	9197	05/06/2013	2013-00000051	4020 - EXEC VEBA *	\$7,000.00
Remit to: MORENO VALLEY, CA					FYTD: \$174,680.03
CITY OF MORENO VALLEY VEBA TRUST	9369	05/20/2013	2013-00000087	4050 - MVCEA VEBA *	\$1,962.50
			130418	EXEMPT VEBA	
Remit to: MORENO VALLEY, CA					FYTD: \$174,680.03
CLS LANDSCAPE MANAGEMENT, INC	217317	05/20/2013	BL#01569-YR2013	REFUND OF OVERPAYMENT FOR BL#01569	\$139.80
Remit to: CHINO, CA					FYTD: \$139.80
CNOA REGION V	217141	05/06/2013	5/9/13 TRAINING	REGISTR. FEES FOR 4 OFFICERS FOR SYNTHETIC DRUG INVESTIG. TRNG	\$180.00



**City of Moreno Valley
Payment Register
For Period 5/1/2013 through 5/31/2013**

CHECKS UNDER \$25,000

<u>Vendor Name</u>	<u>Check/EFT Number</u>	<u>Payment Date</u>	<u>Inv Number</u>	<u>Invoice Description</u>	<u>Payment Amount</u>
Remit to: RANCHO CUCAMONGA, CA					<u>FYTD:</u> \$180.00
COLONIAL SUPPLEMENTAL INSURANCE	217206	05/13/2013	7133069-0501423	SUPPLEMENTAL INSURANCE	\$6,214.34
Remit to: COLUMBIA, SC					<u>FYTD:</u> \$70,574.55
COMMUNITY HEALTH CHARITIES	217083	05/06/2013	2013-00000052	8725 - CH CHARITY	\$94.00
Remit to: COSTA MESA, CA					<u>FYTD:</u> \$4,486.00
COMMUNITY HEALTH CHARITIES	217269	05/20/2013	2013-00000080	8725 - CH CHARITY	\$94.00
Remit to: COSTA MESA, CA					<u>FYTD:</u> \$4,486.00
COMPU COM	217356	05/28/2013	61758460	TWO ADOBE PRO XI LICENSE	\$691.14
			61789447	ACROBAT PRO XI LICENSE-FIRE ADMIN	
Remit to: DALLAS, TX					<u>FYTD:</u> \$118,895.30
CONCRETE CONNECTION, INC	217428	05/28/2013	BL#18389-YR2013	REFUND OF OVERPAYMENT FOR BL#18389	\$96.00
Remit to: CHINO HILLS, CA					<u>FYTD:</u> \$96.00
CONTINENTAL WESTERN TRANSPORTATION	217271	05/20/2013	0104869-IN	ASPHALTIC MATERIAL-SURFACE RECYCLING-MAIN/OPS	\$4,568.78
Remit to: SAN DIEGO, CA					<u>FYTD:</u> \$14,233.89
CORY PETERS	217237	05/13/2013	RCT#0331114	REFUND-CANCELLED CERT CLASS FOR TWO	\$30.00
Remit to: RANCHO CUCAMONGA, CA					<u>FYTD:</u> \$30.00
COUNSELING TEAM, THE	217084	05/06/2013	20967	EMPLOYEE COACHING-PW	\$14,900.00
			20968	EMPLOYEE COACHING-ANIMAL SVCS	



City of Moreno Valley
Payment Register
 For Period 5/1/2013 through 5/31/2013

CHECKS UNDER \$25,000

<u>Vendor Name</u>	<u>Check/EFT Number</u>	<u>Payment Date</u>	<u>Inv Number</u>	<u>Invoice Description</u>	<u>Payment Amount</u>
Remit to: SAN BERNARDINO, CA				<u>FYTD:</u>	\$30,500.00
COUNTRY SQUIRE ESTATES	217357	05/28/2013	MAR 2013	REFUND-UUT-EXEMPT RESIDENTS	\$66.19
Remit to: ONTARIO, CA				<u>FYTD:</u>	\$1,000.69
COUNTY OF RIVERSIDE - RMAP	217085	05/06/2013	IN0167520	ENVIRONMENTAL HEALTH PERMIT-CELEBRATION PARK	\$336.00
Remit to: RIVERSIDE, CA				<u>FYTD:</u>	\$625,364.91
COUNTY OF RIVERSIDE - RMAP	217086	05/06/2013	9990085000-1303	RADIO COMM. SERVICES FOR PD MOTORCYCLES	\$983.50
Remit to: RIVERSIDE, CA				<u>FYTD:</u>	\$625,364.91
COUNTY OF RIVERSIDE - RMAP	217142	05/06/2013	SH0000021347	LAW ENFORCEMENT SVCS/GRANT #PT1303-DISTR. DRIVING ENF.-3/20/13	\$20,492.21
			SH0000021350	LAW ENFORCEMENT SVCS/GRANT #PT1303-DUI STAKEOUT OPER. 3/27/13	
			SH0000021351	LAW ENFORCEMENT SVCS/GRANT #PT1303-DISTR. DRIVING ENF.-3/28/13	
			SH0000021358	LAW ENFORCEMENT SVCS/GRANT #SC13272-DUI CHECKPOINT 3/17/13	
			SH0000021354	LAW ENFORCEMENT SVCS/GRANT #PT1303-DUI SATURATION PATROL-3/29/13	
			SH0000021355	LAW ENFORCEMENT SVCS/GRANT #PT1303-TRAFFIC ENF OPERATION-4/1/13	
			SH0000021357	LAW ENFORCEMENT SVCS/GRANT #SC13272-DUI CHECKPOINT 3/22/13	
			SH0000021346	LAW ENFORCEMENT SVCS/GRANT #PT1303-DISTR. DRIVING ENF.-3/13/13	
			SH0000021356	LAW ENFORCEMENT SVCS/GRANT #PT1303-TRAFFIC ENF OPERATION-4/2/13	



**City of Moreno Valley
Payment Register
For Period 5/1/2013 through 5/31/2013**

CHECKS UNDER \$25,000

<u>Vendor Name</u>	<u>Check/EFT Number</u>	<u>Payment Date</u>	<u>Inv Number</u>	<u>Invoice Description</u>	<u>Payment Amount</u>
Remit to: MORENO VALLEY, CA					<u>FYTD:</u> \$625,364.91
COUNTY OF RIVERSIDE - RMAP	217180	05/13/2013	9990170000-1303	VPN CONNECTION FOR CODE ENFORCEMENT STAFF	\$28.84
Remit to: RIVERSIDE, CA					<u>FYTD:</u> \$625,364.91
COUNTY OF RIVERSIDE - RMAP	217409	05/28/2013	SH0000021404	LAW ENFORCEMENT SVCS/JAG GRANT-EXTRA DUTY/RANCHO VERDE BSKTBALL	\$1,020.18
			SH0000021405	LAW ENFORCEMENT SVCS/JAG GRANT-EXTRA DUTY/RANCHO VERDE CARNIVAL	
Remit to: MORENO VALLEY, CA					<u>FYTD:</u> \$625,364.91
COUNTY OF RIVERSIDE 1	217410	05/28/2013	PU0000002808	JANITORIAL ITEMS FOR STATION EXPLORERS	\$2,493.09
Remit to: MORENO VALLEY, CA					<u>FYTD:</u> \$9,591.31
Crystal Turner	217250	05/13/2013	494343	REFUND PICNIC SHELTER	\$124.80
Remit to: MORENO VALLEY, CA					<u>FYTD:</u> \$124.80
D & D SERVICES DBA D & D DISPOSAL, INC.	217272	05/20/2013	37552	DECEASED ANIMAL REMOVAL-ANIMAL SVCS	\$745.00
Remit to: VALENCIA, CA					<u>FYTD:</u> \$8,195.00
DALE, KATHLEEN	9232	05/06/2013	130501	RETIREE MEDICAL MAY '13	\$318.73
Remit to: MORENO VALLEY, CA					<u>FYTD:</u> \$3,187.30
DANIEL BILLEN	217424	05/28/2013	1037479	REFUND - FOOD SERVICE SPACE FOR JULY 4TH	\$48.00
Remit to: MURRIETA, CA					<u>FYTD:</u> \$48.00
DANIELLE ARIAS	217151	05/06/2013	R13-061115	AS REFUND-RABIES DEPOSIT	\$20.00



**City of Moreno Valley
Payment Register
For Period 5/1/2013 through 5/31/2013**

CHECKS UNDER \$25,000

<u>Vendor Name</u>	<u>Check/EFT Number</u>	<u>Payment Date</u>	<u>Inv Number</u>	<u>Invoice Description</u>	<u>Payment Amount</u>
Remit to: LAKE ELSINORE, CA					<u>FYTD:</u> \$20.00
DATA TICKET, INC.	9370	05/20/2013	45644	NPDES BUSINESS INSPECTION SVCS-JAN13	\$75.00
Remit to: NEWPORT BEACH, CA					<u>FYTD:</u> \$189,141.45
DATA TICKET, INC.	9419	05/28/2013	45587	REAL ESTATE DEMANDS-CODE-FEB13	\$20,070.17
			45636	ADMIN CITATION PROCESSING-CODE-FEB13	
			45688	CITATION PROCESSING-CODE-FEB13	
			2013-0010CM	CREDIT MEMO-FTB REFUND-MVP45974	
Remit to: NEWPORT BEACH, CA					<u>FYTD:</u> \$189,141.45
DATAQUICK CORPORATE HEADQUARTERS	217358	05/28/2013	B1-2157352	ON-LINE SOFTWARE SUBSCRIPTION-POP UNIT	\$130.50
Remit to: LOS ANGELES, CA					<u>FYTD:</u> \$1,435.50
DAVID MUSSER	217419	05/28/2013	MAY-2013	INSTRUCTOR SVCS-WATERCOLOR TECHNIQUE CLASS	\$294.00
Remit to: MENIFEE, CA					<u>FYTD:</u> \$4,578.00
DAVID TURCH & ASSOCIATES	217181	05/13/2013	MAY 2013	FEDERAL LEGISLATIVE ADVOCATE SERVICES 5/1-5/31/13	\$4,166.67
Remit to: WASHINGTON, DC					<u>FYTD:</u> \$45,833.37
DELTA DENTAL OF CALIFORNIA	9199	05/06/2013	BE000539518	EMPLOYEE DENTAL INSURANCE	\$10,856.33
Remit to: SAN FRANCISCO, CA					<u>FYTD:</u> \$114,839.70
DELTACARE USA	217207	05/13/2013	5332184	EMPLOYEE DENTAL INSURANCE	\$5,436.77
Remit to: LOS ANGELES, CA					<u>FYTD:</u> \$62,079.77



**City of Moreno Valley
Payment Register
For Period 5/1/2013 through 5/31/2013**

CHECKS UNDER \$25,000

<u>Vendor Name</u>	<u>Check/EFT Number</u>	<u>Payment Date</u>	<u>Inv Number</u>	<u>Invoice Description</u>	<u>Payment Amount</u>
DENNIS GRUBB & ASSOCIATES, LLC	9200	05/06/2013	1186	PLAN REVIEW SVCS-FIRE PREVENTION	\$5,175.00
Remit to: MIRA LOMA, CA					
DENNIS GRUBB & ASSOCIATES, LLC	9371	05/20/2013	1188	PLAN REVIEW SVCS-FIRE PREVENTION	\$2,450.00
Remit to: MIRA LOMA, CA					
DEPARTMENT OF CONSUMER AFFAIRS	217359	05/28/2013	CERT 53613	CIVIL ENGINEER LICENSE RENEWAL - MARK SAMBITO	\$115.00
Remit to: SACRAMENTO, CA					
DEPARTMENT OF CONSUMER AFFAIRS	217360	05/28/2013	CERT 59025	CIVIL ENGINEER LICENSE RENEWAL - CLEMENT JIMENEZ	\$115.00
Remit to: SACRAMENTO, CA					
DEPARTMENT OF CONSUMER AFFAIRS	217361	05/28/2013	CERT 64747	CIVIL ENGINEER LICENSE RENEWAL - HOANG NGUYEN	\$115.00
Remit to: SACRAMENTO, CA					
DEPARTMENT OF INDUSTRIAL RELATIONS	217273	05/20/2013	S1089751SB	EOC-CAL/OSHA-ELEVATORS	\$675.00
Remit to: SAN FRANCISCO, CA					
DERRICK N. JOSEPH	217345	05/20/2013	MV2120309015	REFUND-CITATION OVERPAYMENT	\$115.00
Remit to: MORENO VALLEY, CA					
DICK HEIL	217448	05/28/2013	REIMB.-LMV	REIMBURSE LUNCH & COFFEE EXPENSES FOR LEADERSHIP MV PROGRAM	\$161.95
Remit to: MORENO VALLEY, CA					



City of Moreno Valley
Payment Register
 For Period 5/1/2013 through 5/31/2013

CHECKS UNDER \$25,000

<u>Vendor Name</u>	<u>Check/EFT Number</u>	<u>Payment Date</u>	<u>Inv Number</u>	<u>Invoice Description</u>	<u>Payment Amount</u>
Remit to: CORONA, CA				<u>FYTD:</u>	\$161.95
DLS LANDSCAPE, INC	9420	05/28/2013	13983	LANDSCAPE MAINT-CFD #1	\$12,390.00
			13984	LANDSCAPE MAINT-ZONE A	
Remit to: REDLANDS, CA				<u>FYTD:</u>	\$136,290.00
DONALD & GUADALUPE NAF	217322	05/20/2013	CERT REFUND	REFUND FOR CANCELLED APRIL CERT CLASS	\$30.00
Remit to: CHINO, CA				<u>FYTD:</u>	\$30.00
DORY, ALLEEN F.	217122	05/06/2013	130501	RETIREE MEDICAL MAY '13	\$146.32
Remit to: HEMET, CA				<u>FYTD:</u>	\$3,060.35
DURAN, BLANCA	217412	05/28/2013	MAY-2013	INSTRUCTOR SVCS-FOLKLORIC DANCE CLASSES	\$171.00
Remit to: MORENO VALLEY, CA				<u>FYTD:</u>	\$1,620.00
DUVAL, ROBERTA	217143	05/06/2013	APR-2013	INSTRUCTOR SVCS-CPR CLASS	\$648.00
Remit to: SUN CITY, CA				<u>FYTD:</u>	\$3,343.13
DUVAL, ROBERTA	217413	05/28/2013	MAY-2013	INSTRUCTOR SVCS-CPR CLASS	\$144.00
Remit to: SUN CITY, CA				<u>FYTD:</u>	\$3,343.13
E.R. BLOCK PLUMBING & HEATING, INC.	9202	05/06/2013	111839	BACKFLOW DEVICE TEST-VRS LOCATIONS	\$500.00
			112155	BACKFLOW DEVICE TEST-VRS LOCATIONS	
Remit to: RIVERSIDE, CA				<u>FYTD:</u>	\$74,276.86
E.R. BLOCK PLUMBING & HEATING, INC.	9372	05/20/2013	112240	REPLACE 2-STOLEN BACKFLOWS-CITY YARD	\$2,372.66



**City of Moreno Valley
Payment Register
For Period 5/1/2013 through 5/31/2013**

CHECKS UNDER \$25,000

<u>Vendor Name</u>	<u>Check/EFT Number</u>	<u>Payment Date</u>	<u>Inv Number</u>	<u>Invoice Description</u>	<u>Payment Amount</u>
Remit to: RIVERSIDE, CA				<u>FYTD:</u>	\$74,276.86
E.R. BLOCK PLUMBING & HEATING, INC.	9421	05/28/2013	112202	BACKFLOW DEVICE TEST-CITY HALL	\$40.00
			112362	BACKFLOW DEVICE TEST-PSB	
Remit to: RIVERSIDE, CA				<u>FYTD:</u>	\$74,276.86
EASTERN MUNICIPAL WATER DISTRICT	217087	05/06/2013	APR-13 5/6/13	WATER CHARGES	\$13,824.46
Remit to: PERRIS, CA				<u>FYTD:</u>	\$1,357,341.38
EASTERN MUNICIPAL WATER DISTRICT	217182	05/13/2013	APR-13 5/13/13	WATER CHARGES	\$7,795.10
Remit to: PERRIS, CA				<u>FYTD:</u>	\$1,357,341.38
EDGELANE MOBILE PARK	9422	05/28/2013	APR 2013	REFUND-UUT-EXEMPT RESIDENTS	\$14.39
Remit to: LOS ANGELES, CA				<u>FYTD:</u>	\$160.50
EDITH B. AYALA	217333	05/20/2013	MVP63679	REFUND-DISMISSED CITATION	\$41.00
Remit to: MORENO VALLEY, CA				<u>FYTD:</u>	\$41.00
EGGERSTEN, ANNE	217123	05/06/2013	130501	RETIREE MEDICAL MAY '13	\$255.43
Remit to: RANCHO MIRAGE, CA				<u>FYTD:</u>	\$2,879.30
EMERGENT BATTERY TECHNOLOGIES, INC.	217451	05/28/2013	18957	BATTERY BACK UP SYSTEMS	\$6,879.60
Remit to: ANAHEIM, CA				<u>FYTD:</u>	\$29,175.30
EMPIRE MOWER	217363	05/28/2013	149754	EQUIPMENT SUPPLIES-CITY PARKS	\$29.70

Item No. A.6



**City of Moreno Valley
Payment Register
For Period 5/1/2013 through 5/31/2013**

CHECKS UNDER \$25,000

<u>Vendor Name</u>	<u>Check/EFT Number</u>	<u>Payment Date</u>	<u>Inv Number</u>	<u>Invoice Description</u>	<u>Payment Amount</u>
Remit to: MORENO VALLEY, CA				<u>FYTD:</u>	\$29.70
EMPLOYMENT DEVELOPMENT DEPARTMENT	9358	05/03/2013	2013-00000069	CA TAX - STATE TAX WITHHOLDING*	\$23.35
Remit to: Unknown, CA				<u>FYTD:</u>	\$940,832.72
EMPLOYMENT DEVELOPMENT DEPARTMENT	9410	05/22/2013	1ST QTR 2013	UNEMPLOYMENT INSURANCE CLAIMS 1/1-3/31/13	\$9,437.00
Remit to: Unknown, CA				<u>FYTD:</u>	\$940,832.72
ENCO UTILITY SERVICES MORENO VALLEY LLC	9203	05/06/2013	0402-MF-01444A	SOLAR METER INSTALLATION-12631 MAGNOLIA DR	\$2,532.00
			0402-MF-01429A R	SOLAR METER INSTALLATION-3 RESIDENCE	
Remit to: ANAHEIM, CA				<u>FYTD:</u>	\$2,347,752.28
ERICK COOPER	217429	05/28/2013	1041053	REFUND-CONTRACT CLASS	\$32.00
Remit to: MORENO VALLEY, CA				<u>FYTD:</u>	\$32.00
EVANS ENGRAVING & AWARDS	9204	05/06/2013	41113-4	OFFICER OF THE YEAR & QTR AWARDS	\$1,189.88
			41113-9	PLAQUE-VOLUNTEER OF THE YR-EMERGENCY MGMT	
			40913-3	EMPLOYEE PLAQUE-BUS SUPPORT/NEIGHBRHD	
			32220	SERVICE AWARDS-APRIL THRU JUNE-HR	
			32413-14	SERVICE AWARDS-DEC 2012 THRU MAR 2013-HR	
Remit to: MORENO VALLEY, CA				<u>FYTD:</u>	\$2,735.72
EXCEL LANDSCAPE, INC	217364	05/28/2013	76481	LANDSCAPE MAINT-ZONE E-7	\$2,802.95
			76577	LANDSCAPE MAINT ADD'L WORK-ZONE E-7	



**City of Moreno Valley
Payment Register
For Period 5/1/2013 through 5/31/2013**

CHECKS UNDER \$25,000

<u>Vendor Name</u>	<u>Check/EFT Number</u>	<u>Payment Date</u>	<u>Inv Number</u>	<u>Invoice Description</u>	<u>Payment Amount</u>
EXCEL LANDSCAPE, INC	217364	05/28/2013	76442	LANDSCAPE MAINT ADD'L WORK-NPDES WQB	\$2,802.95
Remit to: CORONA, CA <u>FYTD:</u> \$101,672.64					
FALLEN OFFICERS FUND	217275	05/20/2013	CONF. REGISTR.	FEES FOR 4 OFFICERS TO ATTEND THE 2013 SO. CA. GANG CONF.	\$340.00
Remit to: CHULA VISTA, CA <u>FYTD:</u> \$340.00					
FEENSTRA, JOHN	9233	05/06/2013	130501	RETIREE MEDICAL MAY '13	\$361.25
Remit to: REDLANDS, CA <u>FYTD:</u> \$3,612.50					
Fidel Ruiz	217243	05/13/2013	494578	REFUND DEPOSIT SENIOR CENTER	\$300.00
Remit to: MORENO VALLEY, CA <u>FYTD:</u> \$300.00					
FIRST AMERICAN CORE LOGIC, INC.	217088	05/06/2013	80808033	REAL QUEST ONLINE PROPERTY SEARCH-CODE	\$640.00
Remit to: DALLAS, TX <u>FYTD:</u> \$7,040.00					
FIRST CHOICE SERVICES	9309	05/13/2013	523392	EMPLOYEE PAID COFFEE SVC-CITY YARD	\$162.89
Remit to: ONTARIO, CA <u>FYTD:</u> \$7,971.92					
FIRST CHOICE SERVICES	9424	05/28/2013	524839	EMPLOYEE PAID COFFEE SVC-CITY YARD	\$336.07
Remit to: ONTARIO, CA <u>FYTD:</u> \$7,971.92					
FIRST CHOICE SERVICES	524837		524837	EMPLOYEE PAID COFFEE SVC-CRC	
FIRST CHOICE SERVICES	524846		524846	EMPLOYEE PAID COFFEE SVC-CITY HALL	
Remit to: ONTARIO, CA <u>FYTD:</u> \$7,971.92					
FITNESS 19 CA 155 11C	217276	05/20/2013	2013-00000081	8730 - GYM MEMBERSHIP*	\$216.00



City of Moreno Valley
Payment Register
 For Period 5/1/2013 through 5/31/2013

CHECKS UNDER \$25,000

<u>Vendor Name</u>	<u>Check/EFT Number</u>	<u>Payment Date</u>	<u>Inv Number</u>	<u>Invoice Description</u>	<u>Payment Amount</u>
Remit to: MORENO VALLEY, CA					<u>FYTD:</u> \$2,214.00
FOSTER, JAMES BARRY	217208	05/13/2013	5/19-5/22/13	TRAVEL PER DIEM-ICSC RECON CONVENTION	\$248.50
Remit to: RIVERSIDE, CA					<u>FYTD:</u> \$474.12
FOSTER, NANCY A.	9234	05/06/2013	130501	RETIREE MEDICAL MAY '13	\$318.73
Remit to: GRASS VALLEY, CA					<u>FYTD:</u> \$3,187.30
FOSTER, ZACHARY F.	9235	05/06/2013	130501	RETIREE MEDICAL MAY '13	\$318.73
Remit to: GRASS VALLEY, CA					<u>FYTD:</u> \$2,549.84
FRANCHISE TAX BOARD	217089	05/06/2013	2013-00000053	1015 - GARNISHMENT - CREDITOR %*	\$311.03
Remit to: SACRAMENTO, CA					<u>FYTD:</u> \$7,243.65
FRANCHISE TAX BOARD	217277	05/20/2013	2013-00000082	1015 - GARNISHMENT - CREDITOR %*	\$311.03
Remit to: SACRAMENTO, CA					<u>FYTD:</u> \$7,243.65
Frank Ochoa	217234	05/13/2013	494342	REFUND DROPPED CLASS	\$90.00
Remit to: MORENO VALLEY, CA					<u>FYTD:</u> \$90.00
FRANKLIN, L. C.	217414	05/28/2013	APR-13 MILEAGE	MILEAGE REIMBURSEMENT	\$210.18
Remit to: PERRIS, CA					<u>FYTD:</u> \$1,769.93
FRAZEE INDUSTRIES, INC	217278	05/20/2013	9530501102730	CREDIT INVOICE FOR RETURNED MATERIALS	\$1,462.56
			9530501102740	GRAFFITI REMOVAL PRODUCTS	
			9530501096253	GRAFFITI REMOVAL PRODUCTS	



**City of Moreno Valley
Payment Register
For Period 5/1/2013 through 5/31/2013**

CHECKS UNDER \$25,000

<u>Vendor Name</u>	<u>Check/EFT Number</u>	<u>Payment Date</u>	<u>Inv Number</u>	<u>Invoice Description</u>	<u>Payment Amount</u>
Remit to: LOS ANGELES, CA					<u>FYTD:</u> \$7,977.57
FREDES PRINTING & SIGNS	217430	05/28/2013	BL#07821-YR2013	REFUND OF OVERPAYMENT FOR BL#07821	\$62.20
Remit to: MORENO VALLEY, CA					<u>FYTD:</u> \$62.20
FRED'S GLASS & MIRROR, INC.	217090	05/06/2013	182405	WINDOW REPAIRS-MARCH FIELD COMM PARK	\$285.50
			182406	WINDOW REPAIRS-MARCH FIELD COMM PARK	
Remit to: RIVERSIDE, CA					<u>FYTD:</u> \$2,812.75
FUSCOE ENGINEERING, INC	217365	05/28/2013	112553	PLAN CHECK SVCS-MAP FOR PM 36508	\$3,058.50
Remit to: IRVINE, CA					<u>FYTD:</u> \$3,058.50
G/M BUSINESS INTERIORS, INC.	217183	05/13/2013	0093496-IN	DESIGN, DISASSEMBLE, RELOCATE & REBUILD FURNITURE AT ANNEX 1	\$24,450.38
Remit to: RIVERSIDE, CA					<u>FYTD:</u> \$197,335.05
G/M BUSINESS INTERIORS, INC.	217184	05/13/2013	0093706-IN	DISASSEMBLE, REINSTALL, DESIGN & STORE FURNITURE-2ND FLR CH	\$24,113.63
Remit to: RIVERSIDE, CA					<u>FYTD:</u> \$197,335.05
GAGATCH, HEATHER	217416	05/28/2013	6/4-6/6/13	TRAVEL PER DIEM FOR ADVANCED CPTED TRAINING	\$150.00
Remit to: MORENO VALLEY, CA					<u>FYTD:</u> \$150.00
GALLS INC., INLAND UNIFORM	9373	05/20/2013	313321	UNIFORM REPLACEMENT-TRAFFIC UNIT	\$95.03
Remit to: RIVERSIDE, CA					<u>FYTD:</u> \$5,033.23
GALLS INC., INLAND UNIFORM	217175	05/06/2013	280163	UNIFORMS-PARK RANGERS	\$205.16



City of Moreno Valley
Payment Register
 For Period 5/1/2013 through 5/31/2013

CHECKS UNDER \$25,000

<u>Vendor Name</u>	<u>Check/EFT Number</u>	<u>Payment Date</u>	<u>Inv Number</u>	<u>Invoice Description</u>	<u>Payment Amount</u>
Remit to: RIVERSIDE, CA				<u>FYTD:</u>	\$5,033.23
GARDNER COMPANY, INC.	217091	05/06/2013	1834	HVAC OPTIMIZATION PREV MAINT-LIBRARY	\$2,750.00
			1833	HVAC OPTIMIZATION PREV MAINT-SENIOR CTR	
Remit to: MURRIETA, CA				<u>FYTD:</u>	\$4,245.79
GARDNER COMPANY, INC.	217185	05/13/2013	52964	HVAC REPAIRS-SENIOR CTR	\$945.79
Remit to: MURRIETA, CA				<u>FYTD:</u>	\$4,245.79
GARDNER COMPANY, INC.	217366	05/28/2013	52965	HVAC REPAIRS-SENIOR CTR	\$550.00
Remit to: MURRIETA, CA				<u>FYTD:</u>	\$4,245.79
GENE ROGERS	217211	05/13/2013	SETTLEMENT	PAYMENT FOR RELEASE OF CLAIM	\$1,750.00
Remit to: PEBBLE BEACH, CA				<u>FYTD:</u>	\$1,750.00
GENERAL SECURITY SERVICES, INC.	9205	05/06/2013	171349	SECURITY SVCS-TOWNGATE-8/11/12	\$1,871.48
			173550	SECURITY SVCS-SENIOR CTR-4/6/13	
			173549	SECURITY SVCS-CRC 4/1-4/4/13	
			173606	SECURITY SVCS-LIBRARY-4/13/13	
			173603	SECURITY SVCS-CRC 4/8-4/11/13	
			173604	SECURITY SVCS-SENIOR CTR-4/13/13	
			173588	SECURITY SVCS-TOWNGATE-4/13/13	
			173527	SECURITY SVCS-TOWNGATE-4/6/13	
			170496	SECURITY SVCS-CRC 4/16-4/20/12	
Remit to: WILMINGTON, CA				<u>FYTD:</u>	\$50,492.36



**City of Moreno Valley
Payment Register
For Period 5/1/2013 through 5/31/2013**

CHECKS UNDER \$25,000

<u>Vendor Name</u>	<u>Check/EFT Number</u>	<u>Payment Date</u>	<u>Inv Number</u>	<u>Invoice Description</u>	<u>Payment Amount</u>
GENERAL SECURITY SERVICES, INC.	9206	05/06/2013	170817	SECURITY SVCS-CRC SPECIAL EVENTS	\$1,015.05
			172026	SECURITY SVCS-CRC 7/9-7/12/12	
			173337	SECURITY SVCS-CRC 3/11-3/14/13	
			172027	SECURITY SVCS-CRC SPECIAL EVENTS	
Remit to: WILMINGTON, CA					FYTD: \$50,492.36
GENERAL SECURITY SERVICES, INC.	9310	05/13/2013	173648	SECURITY SVCS-CRC 4/15-4/18/13	\$2,299.13
			173666	SECURITY SVCS-LIBRARY-4/17>4/20/13	
			173586	RENTAL OF RADIOS & WANDS-7/4/12	
			173724	SECURITY SVCS-CRC 4/22-4/25/13	
			173723	SECURITY SVCS-CITY HALL 4/22-4/25/13	
			173664	SECURITY SVCS-CITY HALL 4/15-4/18/13	
			173704	SECURITY SVCS-TOWNGATE-4/27/13	
			173649	SECURITY SVCS-CRC SPECIAL EVENTS 4/19/13	
			173703	SECURITY SVCS-TOWNGATE-4/26/13	
Remit to: WILMINGTON, CA					FYTD: \$50,492.36
GENERAL SECURITY SERVICES, INC.	9374	05/20/2013	173725	SECURITY SVCS-MVU 4/22-4/25/13	\$1,296.23
			173795	SECURITY SVCS-TOWNGATE-5/1/13	
			173801	SECURITY SVCS-CRC SPECIAL EVENTS 5/3/13	
			173812	SECURITY SVCS-CRC 4/29-5/2/13	
			173665	SECURITY SVCS-SENIOR CTR-4/20/13	
			173800	SECURITY SVCS-CRC SPECIAL EVENTS 5/4/13	



**City of Moreno Valley
Payment Register
For Period 5/1/2013 through 5/31/2013**

CHECKS UNDER \$25,000

<u>Vendor Name</u>	<u>Check/EFT Number</u>	<u>Payment Date</u>	<u>Inv Number</u>	<u>Invoice Description</u>	<u>Payment Amount</u>
Remit to: WILMINGTON, CA				FYTD:	\$50,492.36
GENERAL SECURITY SERVICES, INC.	9425	05/28/2013	173867	SECURITY SVCS-CRC SPECIAL EVENTS 5/9 & 5/10/13	\$1,457.30
			173866	SECURITY SVCS-CRC SPECIAL EVENTS 5/5/13	
			173858	SECURITY SVCS-TOWNGATE-5/11/13	
			173879	SECURITY SVCS-LIBRARY-5/11/13	
			173877	SECURITY SVCS-CITY HALL 5/6-5/9/13	
			173811	SECURITY SVCS-CITY HALL 4/29-5/2/13	
			173878	SECURITY SVCS-CRC 5/6-5/9/13	
			173813	SECURITY SVCS-LIBRARY-4/29 & 5/4/13	
Remit to: WILMINGTON, CA				FYTD:	\$50,492.36
GIBBS, GIDEN, LOCHER, TURNER, SENET & WITTBRODT LLP	9426	05/28/2013	219346-002	LEGAL SERVICES - SUNNYMEAD (EXCEL)	\$1,381.40
			219137-001	LEGAL SERVICES - SUNNYMEAD (EXCEL)	
Remit to: LOS ANGELES, CA				FYTD:	\$209,067.50
GIL'S PLASTERING	217223	05/13/2013	BL#22089-YR2013	REFUND OF OVERPAYMENT FOR B/L #22089	\$86.79
Remit to: MORENO VALLEY, CA				FYTD:	\$86.79
GONZALES, DOMILENA R.	9236	05/06/2013	130501	APR '13 PD MAY '13	\$318.73
Remit to: MORENO VALLEY, CA				FYTD:	\$2,868.57
GORM INC.	217367	05/28/2013	200711	JANITORIAL SUPPLIES-CITY PARKS & CFC#1 PARKS	\$3,401.87
Remit to: ONTARIO, CA				FYTD:	\$8,478.11



**City of Moreno Valley
Payment Register
For Period 5/1/2013 through 5/31/2013**

CHECKS UNDER \$25,000

<u>Vendor Name</u>	<u>Check/EFT Number</u>	<u>Payment Date</u>	<u>Inv Number</u>	<u>Invoice Description</u>	<u>Payment Amount</u>
GOZDECKI, DAN	9375	05/20/2013	MAY-2013 YOUTH MAY-2013 ADULT	INSTRUCTOR SVCS-KUNG FU CLASS INSTRUCTOR SVCS-KUNG FU CLASS	\$513.00
Remit to: MORENO VALLEY, CA <u>FYTD:</u> \$5,762.40					
GRAVES & KING, LLP	217186	05/13/2013	1303-0009442	LEGAL SVCS-MV1261	\$1,468.66
Remit to: RIVERSIDE, CA <u>FYTD:</u> \$5,082.90					
GRAVES & KING, LLP	217368	05/28/2013	1302-0009442	LEGAL SVCS-MV1261	\$1,078.88
Remit to: RIVERSIDE, CA <u>FYTD:</u> \$5,082.90					
GRESHAM SAVAGE NOLAN & TILDEN	217279	05/20/2013	263346	LEGAL SERVICES	\$11,820.26
Remit to: SAN BERNARDINO, CA <u>FYTD:</u> \$11,820.26					
GRIFFIN, MARLENE C	9237	05/06/2013	130501	RETIREE MEDICAL MAY '13	\$255.43
Remit to: GREEN VALLEY, AZ <u>FYTD:</u> \$2,870.80					
GUADALUPE ORTEGA	217236	05/13/2013	R13-057654	AS REFUND-RABIES DEPOSIT	\$20.00
Remit to: RIVERSIDE, CA <u>FYTD:</u> \$20.00					
GUARDSMARK	9207	05/06/2013	5316118	SECURITY SVCS-CITY HALL 4/7-4/13/13	\$267.90
Remit to: RANCHO CUCAMONGA, CA <u>FYTD:</u> \$16,708.03					
GUIDANCE SOFTWARE, INC	217187	05/13/2013	TRNG. PASSPORT	ENCASE 1YR ANNUAL TRAINING PASSPORT FOR JOHN LENTON-QUOTE 68727	\$5,500.00
Remit to: PASADENA, CA <u>FYTD:</u> \$10,295.82					
GUIDANCE SOFTWARE, INC	217280	05/20/2013	3071683	SOFTWARE & MAINT/SUPPORT-4 NEW FORENSIC COMPUTER	\$4,795.82



**City of Moreno Valley
Payment Register
For Period 5/1/2013 through 5/31/2013**

CHECKS UNDER \$25,000

<u>Vendor Name</u>	<u>Check/EFT Number</u>	<u>Payment Date</u>	<u>Inv Number</u>	<u>Invoice Description</u>	<u>Payment Amount</u>
Remit to: PASADENA, CA					<u>FYTD:</u> \$10,295.82
GUILLAN, REBECCA S.	9238	05/06/2013	130501	APR '13, PD MAY '13	\$297.39
Remit to: ADVANCE, NC					<u>FYTD:</u> \$2,829.46
GUTIERREZ, ROBERT	9239	05/06/2013	130501	RETIREE MEDICAL MAY '13	\$318.73
Remit to: LA VERNE, CA					<u>FYTD:</u> \$3,187.30
HAMLIN, WILLIAM R.	9240	05/06/2013	130501	RETIREE MEDICAL MAY '13	\$318.73
Remit to: BEAUMONT, CA					<u>FYTD:</u> \$3,187.30
HANES, MARTIN D.	9241	05/06/2013	130501	RETIREE MEDICAL MAY '13	\$318.73
Remit to: MORENO VALLEY, CA					<u>FYTD:</u> \$3,187.30
HARDING, JOHN	217124	05/06/2013	130501	RETIREE MEDICAL MAY '13	\$318.73
Remit to: BANNING, CA					<u>FYTD:</u> \$3,187.30
HATFIELD, CHARLES	9242	05/06/2013	130501	RETIREE MEDICAL MAY '13	\$318.73
Remit to: LAS VEGAS, NV					<u>FYTD:</u> \$3,187.30
HDL/HINDERLITER DE LLAMAS & ASSOCIATES	217369	05/28/2013	0020875-IN	SALES TAX AUDIT SVCS	\$920.47
Remit to: DIAMOND BAR, CA					<u>FYTD:</u> \$119,390.09
HEFFLEY, ROSS W.	9243	05/06/2013	130501	RETIREE MEDICAL MAY '13	\$318.73
Remit to: HEMET, CA					<u>FYTD:</u> \$3,187.30
Herman Savage	217244	05/13/2013	494383	REFUND JR FLAG FOOTBALL	\$48.00



**City of Moreno Valley
Payment Register
For Period 5/1/2013 through 5/31/2013**

CHECKS UNDER \$25,000

<u>Vendor Name</u>	<u>Check/EFT Number</u>	<u>Payment Date</u>	<u>Inv Number</u>	<u>Invoice Description</u>	<u>Payment Amount</u>
Remit to: MORENO VALLEY, CA					<u>FYTD:</u> \$48.00
HERRICK, ROBERT D.	217126	05/06/2013	130501	RETIREE MEDICAL MAY '13	\$318.73
Remit to: MORENO VALLEY, CA					<u>FYTD:</u> \$3,187.30
HLP, INC.	9376	05/20/2013	7977	WEB LICENSING TRANSACTIONS (AUG/SEPT/OCT 2012)	\$72.45
Remit to: LITTLETON, CO					<u>FYTD:</u> \$21,792.65
HLP, INC.	9429	05/28/2013	8433RV	WEB LICENSING MONTHLY SVCS-APR13	\$40.25
Remit to: LITTLETON, CO					<u>FYTD:</u> \$21,792.65
HOLT, ANITRA N	217127	05/06/2013	130501	RETIREE MEDICAL MAY '13	\$318.73
Remit to: CLERMONT, FL					<u>FYTD:</u> \$1,274.92
HONDA YAMAHA OF REDLANDS	217092	05/06/2013	16500	MAINT & REPAIRS-LABOR & PARTS-TRAFFIC MOTORCYCLES	\$163.46
Remit to: REDLANDS, CA					<u>FYTD:</u> \$24,358.63
HONDA YAMAHA OF REDLANDS	217370	05/28/2013	17748	MAINT & REPAIRS-LABOR & PARTS-TRAFFIC MOTORCYCLES	\$1,890.78
			16822	MAINT & REPAIRS-LABOR & PARTS-TRAFFIC MOTORCYCLES	
			17366	MAINT & REPAIRS-LABOR & PARTS-TRAFFIC MOTORCYCLES	
			16976	MAINT & REPAIRS-LABOR & PARTS-TRAFFIC MOTORCYCLES	
Remit to: REDLANDS, CA					<u>FYTD:</u> \$24,358.63
HOUSER, EDITH E.	217128	05/06/2013	130501	RETIREE MEDICAL MAY '13	\$318.73
Remit to: MORENO VALLEY, CA					<u>FYTD:</u> \$3,187.30
HUNSAKER & ASSOCIATES, INC.	217188	05/13/2013	13030101	PLAN CHECK SVCS-PM 36511	\$6,585.90



**City of Moreno Valley
Payment Register
For Period 5/1/2013 through 5/31/2013**

CHECKS UNDER \$25,000

<u>Vendor Name</u>	<u>Check/EFT Number</u>	<u>Payment Date</u>	<u>Inv Number</u>	<u>Invoice Description</u>	<u>Payment Amount</u>
HUNSAKER & ASSOCIATES, INC.	217188	05/13/2013	13010355	CONSULTING SERVICES - IRIS PAVEMENT RESURFACING	\$6,585.90
			13010375	CONSULTING SERVICES, SURVEY - PERRIS BLVD. WIDENING	
			13020333	CONSULTING SERVICES, SURVEY - PERRIS BLVD. WIDENING	
Remit to: IRVINE, CA					<u>FYTD:</u> \$90,602.21
ICMA RETIREMENT CORP	9293	05/03/2013	2013-00000044	8030 - DEF COMP 457 - ICMA	\$15,094.64
Remit to: BALTIMORE, MD					<u>FYTD:</u> \$231,545.24
ICMA RETIREMENT CORP	9403	05/16/2013	2013-00000076	8030 - DEF COMP 457 - ICMA	\$13,707.14
Remit to: BALTIMORE, MD					<u>FYTD:</u> \$231,545.24
ICR DOORS	9377	05/20/2013	643	MAINT. OF TWO ROLL UP DOORS-ANNEX 1	\$113.00
Remit to: UPLAND, CA					<u>FYTD:</u> \$7,041.97
IES COMMERCIAL, INC	217256	05/13/2013	97780	REMOVE/RELOCATE EXISTING ACCESS CONTROL SYSTEM TO ANNEX1	\$6,954.29
Remit to: TEMPE, AZ					<u>FYTD:</u> \$20,269.22
IL SORRENTO MOBILE PARK	217371	05/28/2013	MARCH 2013	MISCELLANEOUS SERVICES	\$71.01
Remit to: MORENO VALLEY, CA					<u>FYTD:</u> \$1,152.71
ING USA ANNUITY & LIFE INSURANCE CO.	217281	05/20/2013	2013-00000083	8792 - ING - EMPLOYEE *	\$325.00
Remit to: DES MOINES, IA					<u>FYTD:</u> \$4,100.00
INLAND PETROLEUM EQUIPMENT & REPAIR, INC	9208	05/06/2013	316658	FUEL DISPENSERS CARB TESTING & REPAIRS-FS#65	\$2,612.02
			316657	FUEL DISPENSERS CARB TESTING & REPAIRS-FS#48	



**City of Moreno Valley
Payment Register
For Period 5/1/2013 through 5/31/2013**

CHECKS UNDER \$25,000

<u>Vendor Name</u>	<u>Check/EFT Number</u>	<u>Payment Date</u>	<u>Inv Number</u>	<u>Invoice Description</u>	<u>Payment Amount</u>
INLAND PETROLEUM EQUIPMENT & REPAIR, INC	9208	05/06/2013	316659	FUEL DISPENSERS CARB TESTING & REPAIRS-FS#65	\$2,612.02
Remit to: BLOOMINGTON, CA					
				FYTD:	\$3,907.93
INLAND PETROLEUM EQUIPMENT & REPAIR, INC	9311	05/13/2013	316656	FUEL DISPENSERS CARB TESTING & REPAIRS-FS#2	\$1,019.11
Remit to: BLOOMINGTON, CA					
				FYTD:	\$3,907.93
INSIDE PLANTS, INC.	217189	05/13/2013	46808	INDOOR PLANT MAINT-CRC-MAY13	\$320.00
Remit to: CORONA, CA					
INTERNAL REVENUE SERVICE CENTER	9359	05/09/2013	F130502	MISCELLANEOUS SERVICES	\$12,982.85
Remit to: OGDEN, UT					
				FYTD:	\$508,592.52
J D H CONTRACTING	9209	05/06/2013	041113-01	REMOVE WALL-CH COUNCIL AREA	\$2,790.00
			041113-02	REPAIRS/ADJUSTMENT-PW LOBBY DOOR	
			041813-02	FABRICATE & INSTALL LIGHT COVERS-PSB	
			041813-03	RE-INSTALL LARGE CONCRETE BALL	
Remit to: RIVERSIDE, CA					
				FYTD:	\$131,322.90
J D H CONTRACTING	9312	05/13/2013	042513-02	INSTALL 3 DRINKING FOUNTAINS-WOODLAND PARK	\$9,833.00
			050613-02	REPLACED DRINKING FOUNTAIN AT SHADOW MOUNTAIN PARK	
			041813-01	FINISH OFF WALL PATCH & PAINT-F/S#65	
Remit to: RIVERSIDE, CA					
				FYTD:	\$131,322.90
J D H CONTRACTING	9378	05/20/2013	051013-01	INSTALL 5 NEW PARKING BUMPERS-MV LIBRARY	\$785.00



**City of Moreno Valley
Payment Register
For Period 5/1/2013 through 5/31/2013**

CHECKS UNDER \$25,000

<u>Vendor Name</u>	<u>Check/EFT Number</u>	<u>Payment Date</u>	<u>Inv Number</u>	<u>Invoice Description</u>	<u>Payment Amount</u>
Remit to: RIVERSIDE, CA				<u>FYTD:</u>	\$131,322.90
J D H CONTRACTING	9430	05/28/2013	052013-01	INSTALL ROOF ON WESTOS PARK RESTROOM	\$7,785.00
Remit to: RIVERSIDE, CA				<u>FYTD:</u>	\$131,322.90
JACK HENRY & ASSOCIATES	217093	05/06/2013	1417378	PROFIT STARS MONTHLY SERVICE FEES	\$302.95
Remit to: MONETT, MO				<u>FYTD:</u>	\$3,058.30
JAM FIRE PROTECTION, INC	217372	05/28/2013	162342	SEMI-ANNUAL INSPECTION/FM-200 PRE-ACTION FIRE SUPPRESSION	\$575.00
Remit to: MONROVIA, CA				<u>FYTD:</u>	\$575.00
JAMES D SMITH	217350	05/20/2013	REFUND CITATIONS	REFUND-CITATION OVERPYMT/MV2110428009, MV2110707014, MV210303011	\$345.00
Remit to: MORENO VALLEY, CA				<u>FYTD:</u>	\$345.00
James Harrison	217226	05/13/2013	493580	REFUND - RAIN OUT SHELTER	\$80.00
Remit to: MORENO VALLEY, CA				<u>FYTD:</u>	\$80.00
JANET LUCIANO	217433	05/28/2013	CK#193111	REISSUE UNCLAIMED CK#193111 DTD 3/5/09	\$73.00
Remit to: RIVERSIDE, CA				<u>FYTD:</u>	\$73.00
JANNEY & JANNEY ATTORNEY SVCS, INC.	217190	05/13/2013	00130433036	MONTHLY RETAINER-DELIVERY OF COURT FILINGS-MAY13	\$75.00
Remit to: RIVERSIDE, CA				<u>FYTD:</u>	\$1,540.00
JENNIFER GUTIERREZ	217225	05/13/2013	R13-061687	AS REFUND-RABIES DEPOSIT	\$20.00
Remit to: MORENO VALLEY, CA				<u>FYTD:</u>	\$20.00



**City of Moreno Valley
Payment Register
For Period 5/1/2013 through 5/31/2013**

CHECKS UNDER \$25,000

<u>Vendor Name</u>	<u>Check/EFT Number</u>	<u>Payment Date</u>	<u>Inv Number</u>	<u>Invoice Description</u>	<u>Payment Amount</u>
JESSICA RODRIGUEZ	217242	05/13/2013	R13-059255	AS REFUND-RABIES DEPOSIT	\$20.00
Remit to: MORENO VALLEY, CA					
JESUS HOLGUIN	217431	05/28/2013	1038029	REFUND - DEPOSIT FOR BALLET FOLKLORICO	\$500.00
Remit to: MORENO VALLEY, CA					
JOE A. GONSALVES & SON	9313	05/13/2013	23586	STATE LEGISLATIVE ADVOCACY SVCS-MAY13	\$3,000.00
Remit to: SACRAMENTO, CA					
JOEL MORALES	217209	05/13/2013	5/20-5/24/13	TRAVEL PER DIEM-OFFICER-INVOLVED SHOOTING & FORCE INVESTIG TRNG.	\$250.00
Remit to: MORENO VALLEY, CA					
JOHN O'DONOHNE	217438	05/28/2013	R13-060317	AS REFUND-OVERPMT ON LICENSE	\$88.00
Remit to: MORENO VALLEY, CA					
JOHN W. STRICKLER	9282	05/06/2013	130501	RETIREE MEDICAL MAY '13	\$318.73
Remit to: SAN BERNARDINO, CA					
JONES, SUSAN	9244	05/06/2013	130501	RETIREE MEDICAL MAY '13	\$318.73
Remit to: MORENO VALLEY, CA					
JORGE ALBERTO HERNANDEZ	217343	05/20/2013	MV3110621015	REFUND-CITATION OVERPAYMENT	\$115.00
Remit to: BEAUMONT, CA					
JORRY KEITH	217145	05/06/2013	APR-2013	INSTRUCTOR SVCS-COMIC BOOK CREATION CLASS	\$120.00
Remit to: FONTANA, CA					



City of Moreno Valley
Payment Register
 For Period 5/1/2013 through 5/31/2013

CHECKS UNDER \$25,000

<u>Vendor Name</u>	<u>Check/EFT Number</u>	<u>Payment Date</u>	<u>Inv Number</u>	<u>Invoice Description</u>	<u>Payment Amount</u>
JOSE BAUTISTA	217218	05/13/2013	R13-059128	AS REFUND-RABIES DEPOSIT	\$20.00
Remit to: MORENO VALLEY, CA					
JOSEPH SANCHEZ	217349	05/20/2013	MV2120120012	REFUND-CITATION OVERPAYMENT	\$115.00
Remit to: MORENO VALLEY, CA					
JOSE'S MEXICAN FOOD	217227	05/13/2013	BL#10717-YR2013	REFUND OF OVERPAYMENT FOR B/L #10717	\$32.83
Remit to: SAN BERNARDINO, CA					
JOSHUA MANJARREZ	217305	05/20/2013	5/28-5/30/13	TRAVEL PER DIEM-TRAINING/SOUTHERN CA. GANG CONFERENCE	\$150.00
Remit to: MORENO VALLEY, CA					
JUSTIN HILL	217304	05/20/2013	5/28-5/30/13	TRAVEL PER DIEM-TRAINING/SOUTHERN CA. GANG CONFERENCE	\$150.00
Remit to: MORENO VALLEY, CA					
KASEY RETHERFORD	217166	05/06/2013	R13-060184	AS REFUND-SN DEPOSIT	\$75.00
Remit to: BANNING, CA					
KATRINA BERMUDEZ	217316	05/20/2013	R13-059422	AS REFUND-RABIES DEPOSIT	\$20.00
Remit to: MORENO VALLEY, CA					
KAYLA CLARIN	217221	05/13/2013	R13-061725	AS REFUND-ADOPT.,VACCINES,MICROCHIP,	\$67.00
Remit to: RIVERSIDE, CA					
KENYA BURTON	217152	05/06/2013	R13-060241	AS REFUND-ADOPT,VACS,CHIP,	\$87.00
Remit to: PERRIS, CA					



**City of Moreno Valley
Payment Register
For Period 5/1/2013 through 5/31/2013**

CHECKS UNDER \$25,000

<u>Vendor Name</u>	<u>Check/EFT Number</u>	<u>Payment Date</u>	<u>Inv Number</u>	<u>Invoice Description</u>	<u>Payment Amount</u>
KEPLER, JANELLE	9379	05/20/2013	MAY-2013	INSTRUCTOR SVCS-CHEERLEADING CLASS	\$596.40
Remit to: RIVERSIDE, CA					
KEVIN J RICHARDSON	217348	05/20/2013	MV2110922021	REFUND-CITATION OVERPAYMENT	\$115.00
Remit to: MORENO VALLEY, CA					
KING, PATRICIA A.	217129	05/06/2013	130501	RETIREE MEDICAL MAY '13	\$210.74
Remit to: LAS VEGAS, NV					
KOLB, CHARLES E.	9245	05/06/2013	130501	RETIREE MEDICAL MAY '13	\$318.73
Remit to: MORENO VALLEY, CA					
KOLLAR, KYLE	9246	05/06/2013	130501	RETIREE MEDICAL MAY '13	\$318.73
Remit to: MORENO VALLEY, CA					
KRISTEN BAUDER	217315	05/20/2013	R13-060712	AS REFUND-RABIES DEPOSIT	\$20.00
Remit to: MORENO VALLEY, CA					
KRONICK, MOSKOVITZ, TIEDEMANN & GIRARD	9210	05/06/2013	266282	LEGAL SVCS-DISSOLUTION OF REDEVT.	\$3,300.60
Remit to: SACRAMENTO, CA					
KUPSAK, STEVE	9247	05/06/2013	130501	MAR '13, PD MAY '13	\$318.73
Remit to: CEDAR GLEN, CA					
KYLE, GARY M.	9248	05/06/2013	130501	RETIREE MEDICAL MAY '13	\$318.73
Remit to: PRESCOTT VALLEY, AZ					



**City of Moreno Valley
Payment Register
For Period 5/1/2013 through 5/31/2013**

CHECKS UNDER \$25,000

<u>Vendor Name</u>	<u>Check/EFT Number</u>	<u>Payment Date</u>	<u>Inv Number</u>	<u>Invoice Description</u>	<u>Payment Amount</u>
L&L ENVIRONMENTAL, INC	217264	05/13/2013	10.1.3950	PROFESSIONAL CONSULTANT SVCS	\$1,931.06
Remit to: REDLANDS, CA					
LADY FOOT LOCKER #6515	217228	05/13/2013	BL#03807-YR2013	REFUND OF OVERPAYMENT FOR B/L #03807	\$77.69
Remit to: HARRISBURG, PA					
LAFATA, JOSEPHINE	9249	05/06/2013	130501	RETIREE MEDICAL MAY '13	\$318.73
Remit to: MORENO VALLEY, CA					
LANGENDORF, BENJAMIN	9250	05/06/2013	130501	FEB-MAR '13, PD MAY '13	\$637.46
Remit to: PERRIS, CA					
LARISSA OCEGUERA	217233	05/13/2013	R13-061137	AS REFUND-SPAY/NEUTER DEPOSIT	\$75.00
Remit to: RIVERSIDE, CA					
LATITUDE GEOGRAPHICS	217373	05/28/2013	201300369	GIS SOFTWARE & SERVICES-M4	\$23,836.77
Remit to: VICTORIA, BC					
LAURA MADERAS	217230	05/13/2013	P217283	AS REFUND-RABIES DEPOSITS FOR 12 DOGS AT \$20.00 EACH	\$240.00
Remit to: SAN MARCOS, CA					
LAURA YENULONIS	217173	05/06/2013	B1300741	REFUND PERMIT FEE-CC CHARGED TWICE IN ERROR	\$60.00
Remit to: COLTON, CA					
LAWSON PRODUCTS, INC.	9431	05/28/2013	1020128	CREDIT INVOICE FOR RETURNED MATERIALS	\$152.84
			9301448215	HARDWARE & BLDG. SUPPLIES-CITY PARKS	



**City of Moreno Valley
Payment Register
For Period 5/1/2013 through 5/31/2013**

CHECKS UNDER \$25,000

<u>Vendor Name</u>	<u>Check/EFT Number</u>	<u>Payment Date</u>	<u>Inv Number</u>	<u>Invoice Description</u>	<u>Payment Amount</u>
Remit to: CHICAGO, IL				<u>FYTD:</u>	\$1,161.73
LEAGUE OF CALIFORNIA CITIES- RIV CNTY DIV 1	217094	05/06/2013	5/13/13 GEN. MTG	COUNCIL MEMBER R. STEWART FOR ATTENDANCE OF GENERAL MEETING	\$25.00
Remit to: MIRA LOMA, CA				<u>FYTD:</u>	\$315.00
LEIGHTON CONSULTING, INC.	9398	05/20/2013	11632	CONSULTING SERVICES - SR-60/NASON OC	\$17,358.87
Remit to: IRVINE, CA				<u>FYTD:</u>	\$332,945.26
LEIVAS LIGHTING, INC	217229	05/13/2013	BL#23962-YR2013	REFUND OF OVERPAYMENT FOR B/L #23962	\$64.38
Remit to: RIVERSIDE, CA				<u>FYTD:</u>	\$64.38
LEIVAS, INC. DBA. LEIVAS LIGHTING	9314	05/13/2013	236096	LANDSCAPE LIGHTING MAINT-E1, E2, E3, E7, M	\$2,820.38
			236038	LANDSCAPE LIGHTING MAINT-ZONE M	
			236039	LANDSCAPE LIGHTING MAINT-TOWNGATE	
			236040	LANDSCAPE LIGHTING MAINT-CENTERPOINTE	
			298	LANDSCAPE LIGHTING MAINT-ZONE E3	
			236042	LANDSCAPE LIGHTING MAINT-ZONE E3	
			236063	LANDSCAPE LIGHTING MAINT-ZONE E2	
			236075	LANDSCAPE LIGHTING MAINT-E1, E2, E3, E7, M	
			292	LANDSCAPE LIGHTING MAINT-ZONE E3	
			294	LANDSCAPE LIGHTING MAINT-ZONE E3	
			296	LANDSCAPE LIGHTING MAINT-ZONE E3	
Remit to: RIVERSIDE, CA				<u>FYTD:</u>	\$5,762.64



City of Moreno Valley
Payment Register
 For Period 5/1/2013 through 5/31/2013

CHECKS UNDER \$25,000

<u>Vendor Name</u>	<u>Check/EFT Number</u>	<u>Payment Date</u>	<u>Inv Number</u>	<u>Invoice Description</u>	<u>Payment Amount</u>
LEIVAS, INC. DBA. LEIVAS LIGHTING	9432	05/28/2013	236130	LANDSCAPE LIGHTING MAINT-E1, E2, E3, E7, M	\$125.00
Remit to: RIVERSIDE, CA					
LETICIA REYES	217347	05/20/2013	MVP63689	REFUND-CITATION DISMISSED	\$407.50
Remit to: MIRA LOMA, CA					
LEWIS BRISBOIS BISGAARD & SMITH LLP	9380	05/20/2013	1166383	LEGAL SVCS-RICS33180	\$4,182.70
Remit to: SAN BERNARDINO, CA					
LEWIS, CAROLYN S.	9251	05/06/2013	130501	RETIREE MEDICAL MAY '13	\$318.73
Remit to: MIDLAND, TX					
LEXISNEXIS PRACTICE MGMT.	9381	05/20/2013	1304081613	ONLINE LEGAL RESEARCH TOOLS-APRIL13	\$1,180.00
Remit to: LOS ANGELES, CA					
LIEBERT, CASSIDY, WHITMORE	217191	05/13/2013	163392	LEGAL SVCS/MO140-00001	\$870.00
Remit to: LOS ANGELES, CA					
LIEBERT, CASSIDY, WHITMORE	217374	05/28/2013	158854	LEGAL SERVICES-MO140-00010	\$2,490.50
Remit to: LOS ANGELES, CA					
LILIANA ALVARADO	217303	05/20/2013	REIMB	REIMB-TRAINING REGIS & BOOKS-HR MGT COURSE-UCR EXT	\$618.48
Remit to: MORENO VALLEY, CA					
LINDO, HERMINA G.	9252	05/06/2013	130501	MAR '13 TRI&MED PD MAY '13	\$232.24
Remit to: LOS ANGELES, CA					



City of Moreno Valley
Payment Register
 For Period 5/1/2013 through 5/31/2013

CHECKS UNDER \$25,000

<u>Vendor Name</u>	<u>Check/EFT Number</u>	<u>Payment Date</u>	<u>Inv Number</u>	<u>Invoice Description</u>	<u>Payment Amount</u>
Remit to: TITUSVILLE, FL				<u>FYTD:</u>	\$1,763.22
LISA TERRY	217444	05/28/2013	R13-062295	AS REFUND-LIC EH SN-SERVICE DOG NO CHRG	\$6.00
Remit to: CORONA, CA				<u>FYTD:</u>	\$6.00
LOGAN, CHARLES	9253	05/06/2013	130501	RETIREE MEDICAL MAY '13	\$318.73
Remit to: LAS VEGAS, NV				<u>FYTD:</u>	\$3,187.30
LONGDYKE, DENNIS	9254	05/06/2013	130501	RETIREE MEDICAL MAY '13	\$318.73
Remit to: BEAUMONT, CA				<u>FYTD:</u>	\$3,187.30
LORENA ARZATE	217215	05/13/2013	CK#190200	REISSUE UNCLAIMED CK#190200 DTD 11/13/08	\$72.13
Remit to: MORENO VALLEY, CA				<u>FYTD:</u>	\$72.13
LORENO CASTANEDA	217425	05/28/2013	1040616	REFUND - SENIOR CENTER RENTAL CONTRACT 23262	\$285.00
Remit to: MORENO VALLEY, CA				<u>FYTD:</u>	\$285.00
LORENO CASTANEDA	217426	05/28/2013	1040622	REFUND - RENTAL DEPOSIT CONTRACT 23262	\$15.00
Remit to: MORENO VALLEY, CA				<u>FYTD:</u>	\$15.00
LORENO CASTANEDA	217427	05/28/2013	1040619	MISCELLANEOUS SERVICES	\$1.00
Remit to: MORENO VALLEY, CA				<u>FYTD:</u>	\$1.00
LORI BARTIE	217217	05/13/2013	7011017-03	SOLAR INCENTIVE REBATE	\$12,246.75
Remit to: MORENO VALLEY, CA				<u>FYTD:</u>	\$12,246.75
LUMLEY, ROBERT C.	9255	05/06/2013	130501	RETIREE MEDICAL MAY '13	\$318.73



**City of Moreno Valley
Payment Register
For Period 5/1/2013 through 5/31/2013**

CHECKS UNDER \$25,000

<u>Vendor Name</u>	<u>Check/EFT Number</u>	<u>Payment Date</u>	<u>Inv Number</u>	<u>Invoice Description</u>	<u>Payment Amount</u>
Remit to: MORENO VALLEY, CA					<u>FYTD:</u> \$3,187.30
MALCOLM SMITH MOTORCYCLES, INC.	9211	05/06/2013	100056800	PURCHASE OF NEW BOOTS FOR MOTOR OFFICERS	\$351.00
Remit to: RIVERSIDE, CA					<u>FYTD:</u> \$36,824.15
MALCOLM SMITH MOTORCYCLES, INC.	9433	05/28/2013	100059811	MAINT & REPAIRS-LABOR & PARTS-TRAFFIC MOTORCYCLES	\$1,125.94
Remit to: RIVERSIDE, CA					<u>FYTD:</u> \$36,824.15
MARCH JOINT POWERS AUTHORITY	217095	05/06/2013	0027443	GAS CHARGES-BLDG 823-MAR13	\$6.85
			0027447	GAS CHARGES-BLDG 938-MAR13	
Remit to: RIVERSIDE, CA					<u>FYTD:</u> \$70.62
MARIA DIAZ	217154	05/06/2013	R13-061315	AS REFUND-RAB DEP, LIC 1 SN	\$35.00
Remit to: MORENO VALLEY, CA					<u>FYTD:</u> \$35.00
MARIA DIAZ	217319	05/20/2013	R13-061315	AS REFUND-ADOPTION,VACCINES	\$51.00
Remit to: MORENO VALLEY, CA					<u>FYTD:</u> \$51.00
MARIA TORRES	217170	05/06/2013	1029491	REFUND FOR RENTAL DEPOSIT	\$300.00
Remit to: MORENO VALLEY, CA					<u>FYTD:</u> \$300.00
MARILYN KOSTRY	217160	05/06/2013	R13-061287	AS REFUND-PD FOR 3YR LIC, REF 2YR	\$18.00
Remit to: MORENO VALLEY, CA					<u>FYTD:</u> \$18.00
MARINA LANDSCAPE, INC	9212	05/06/2013	8216031301	LANDSCAPE MAINT-ZONE E-1/E-1A-ADDL WORK-MAR13	\$234.21



**City of Moreno Valley
Payment Register
For Period 5/1/2013 through 5/31/2013**

CHECKS UNDER \$25,000

<u>Vendor Name</u>	<u>Check/EFT Number</u>	<u>Payment Date</u>	<u>Inv Number</u>	<u>Invoice Description</u>	<u>Payment Amount</u>
Remit to: ANAHEIM, CA					<u>FYTD:</u> \$86,665.30
MARINA LANDSCAPE, INC	9434	05/28/2013	8216041301	LANDSCAPE LIGHTING MAINT-TOWNGATE-ADDL WORK	\$5,929.44
			8216041300	LANDSCAPE MAINT-ZONE E-1/E-1A-APR13	
Remit to: ANAHEIM, CA					<u>FYTD:</u> \$86,665.30
MARIPOSA HORTICULTURAL ENTERPRISES, INC.	9435	05/28/2013	59505	LANDSCAPE MAINT-ZONE DSG-2 ADDL WORK-APR13	\$17,887.01
			59059	LANDSCAPE MAINT-DSG 2 AREAS-ADDL WORK-FEB13	
			59494	LANDSCAPE MAINT-ZONE DSG-2 BASE-APR13	
Remit to: IRWINDALE, CA					<u>FYTD:</u> \$149,636.99
MARK AURE	217216	05/13/2013	R13-058628	AS REFUND-RABIES DEPOSIT	\$20.00
Remit to: MORENO VALLEY, CA					<u>FYTD:</u> \$20.00
MARK SPRUNT	217328	05/20/2013	1038861	REFUND FOR TOWNGATE DEPOSIT	\$200.00
Remit to: MORENO VALLEY, CA					<u>FYTD:</u> \$200.00
Marnie Moore	217231	05/13/2013	495583	REFUND DEPOSIT - SENIOR CENTER	\$300.00
Remit to: MORENO VALLEY, CA					<u>FYTD:</u> \$300.00
MARTHA ORTEGA	217439	05/28/2013	R13-061232	AS REFUND-ADOPTION,VACCINES,MICROCHIP	\$57.00
Remit to: RIVERSIDE, CA					<u>FYTD:</u> \$57.00
MARTHA A. CHAVIRA	217336	05/20/2013	MV4111007005	REFUND-CITATION OVERPAYMENT	\$57.00
Remit to: MORENO VALLEY, CA					<u>FYTD:</u> \$57.00



**City of Moreno Valley
Payment Register
For Period 5/1/2013 through 5/31/2013**

CHECKS UNDER \$25,000

<u>Vendor Name</u>	<u>Check/EFT Number</u>	<u>Payment Date</u>	<u>Inv Number</u>	<u>Invoice Description</u>	<u>Payment Amount</u>
MARY L. BUTLER	217335	05/20/2013	MV2110729005	REFUND-CITATION OVERPAYMENT	\$100.00
Remit to: MORENO VALLEY, CA					
MATHIS, NOLAN	9256	05/06/2013	130501	MAR '13, PD MAY '13	\$298.20
Remit to: JACKSON, KY					
MATCH CORPORATION	217282	05/20/2013	157127	ASPHALTIC MATERIALS	\$12,335.00
Remit to: HIGHLAND, CA					
MAXIMUS CONSULTING SERVICES, INC.	217192	05/13/2013	001	DEVELOPMENT OF FY 12/13 CAP/ICRP	\$17,250.00
Remit to: RANCHO CORDOVA, CA					
MAXINOSKI, SUE A.	9257	05/06/2013	130501	RETIREE MEDICAL MAY '13	\$318.73
Remit to: AVINGER, TX					
MEEKS, DANIEL	9213	05/06/2013	042113 / 042813	SPORTS OFFICIATING SERVICES	\$100.00
Remit to: PERRIS, CA					
MEGAN CONATSER	217318	05/20/2013	R13-060610	AS REFUND-SPAY/NEUTER DEPOSIT	\$75.00
Remit to: MORENO VALLEY, CA					
MELAD & ASSOCIATES, INC	217257	05/13/2013	MV13-001	PLAN CHECK SVCS-B&S	\$765.00
Remit to: HUNTINGTON BEACH, CA					
MENGISTU, YESHIALEM	217417	05/28/2013	APR-13 MILEAGE	MILEAGE REIMBURSEMENT	\$167.81
Remit to: MORENO VALLEY, CA					



**City of Moreno Valley
Payment Register
For Period 5/1/2013 through 5/31/2013**

CHECKS UNDER \$25,000

<u>Vendor Name</u>	<u>Check/EFT Number</u>	<u>Payment Date</u>	<u>Inv Number</u>	<u>Invoice Description</u>	<u>Payment Amount</u>
MERCHANTS LANDSCAPE SERVICES INC	9315	05/13/2013	39665	LANDSCAPE MAINT-ZONE E3 & E3A-MAR13	\$11,573.86
			39716	LANDSCAPE MAINT-ZONE E3-ADDL WORK-MAR13	
Remit to: Santa Ana, CA					<u>FYTD:</u> \$213,644.13
MERCHANTS LANDSCAPE SERVICES INC	9436	05/28/2013	39885	LANDSCAPE MAINT-ZONE E3 & E3A-APR13	\$21,732.52
			39884	LANDSCAPE MAINT-ZONE E8,E12,E14 & E15-APR13	
			40076	LANDSCAPE MAINT-ZONE E3-ADDL WORK-APR13	
			40022	LANDSCAPE MAINT-ZONE E8-ADDL WORK	
Remit to: Santa Ana, CA					<u>FYTD:</u> \$213,644.13
MESSIN, LOUIS	9258	05/06/2013	130501	RETIREE MEDICAL MAY '13	\$318.73
Remit to: BULLHEAD CITY, AZ					<u>FYTD:</u> \$3,187.30
MEYERS, NAVE, RIBACK, SILVER & WILSON	217096	05/06/2013	2013030736	LEGAL SVCS-MAR13	\$7,190.93
Remit to: OAKLAND, CA					<u>FYTD:</u> \$125,860.62
MEYERS, NAVE, RIBACK, SILVER & WILSON	217375	05/28/2013	2013040610	LEGAL SVCS-APR13	\$24,240.58
			2013040609	LEGAL SVCS-MARCH JPA	
			2013040608	LEGAL SVCS-GENERAL ATTY SVCS	
Remit to: OAKLAND, CA					<u>FYTD:</u> \$125,860.62
MEYERS, ROBERT	217147	05/06/2013	APR-2013	INSTRUCTOR SVCS-DRAWING FOR KIDS & PHOTOGRAPHY CLASSES	\$336.00



**City of Moreno Valley
Payment Register
For Period 5/1/2013 through 5/31/2013**

CHECKS UNDER \$25,000

<u>Vendor Name</u>	<u>Check/EFT Number</u>	<u>Payment Date</u>	<u>Inv Number</u>	<u>Invoice Description</u>	<u>Payment Amount</u>
Remit to: MORENO VALLEY, CA					<u>FYTD:</u> \$1,626.60
MICHELE MCKAY	217162	05/06/2013	R12-056949	AS REFUND-RAB/SN DEP FR FORFEIT ACCT	\$95.00
Remit to: ORANGE, CA					<u>FYTD:</u> \$95.00
MICHELLE GOMEZ	217320	05/20/2013	R13-061623	AS REFUND-CAT ADOPTION,VACS,CHIP	\$46.00
Remit to: MORENO VALLEY, CA					<u>FYTD:</u> \$46.00
MICHELLE COOK	217337	05/20/2013	MV2120911035	REFUND-DISMISSED CITATION	\$115.00
Remit to: PERRIS, CA					<u>FYTD:</u> \$115.00
Mikell Phillips	217238	05/13/2013	493985	REFUND SHELTER LESS 20%	\$92.00
Remit to: MORENO VALLEY, CA					<u>FYTD:</u> \$92.00
MILES, ROBERT	9259	05/06/2013	130501	RETIREE MEDICAL MAY '13	\$146.32
Remit to: MORENO VALLEY, CA					<u>FYTD:</u> \$1,861.55
MINARD, MARK E.	9260	05/06/2013	130501	RETIREE MEDICAL MAY '13	\$318.73
Remit to: REDLANDS, CA					<u>FYTD:</u> \$3,187.30
MIREYA GALVAN	217155	05/06/2013	1036474	REFUNDS FOR RENTALS	\$200.00
Remit to: MORENO VALLEY, CA					<u>FYTD:</u> \$200.00
MISTRETTA, ARTHUR	9456	05/28/2013	050913	SPORTS OFFICIATING SERVICES-SOFTBALL	\$60.00
Remit to: MORENO VALLEY, CA					<u>FYTD:</u> \$900.00
MODERN IMAGE	217435	05/28/2013	BL#04468-YR2013	REFUND OF OVERPAYMENT FOR BL#04468	\$60.45



**City of Moreno Valley
Payment Register
For Period 5/1/2013 through 5/31/2013**

CHECKS UNDER \$25,000

<u>Vendor Name</u>	<u>Check/EFT Number</u>	<u>Payment Date</u>	<u>Inv Number</u>	<u>Invoice Description</u>	<u>Payment Amount</u>
Remit to: MORENO VALLEY, CA					<u>FYTD:</u> \$60.45
MOLLICA, MIKE	9261	05/06/2013	130501	RETIREE MEDICAL MAY '13	\$401.42
Remit to: DUNNELLO, FL					<u>FYTD:</u> \$4,014.20
MONOPRICE, INC.	217376	05/28/2013	8274244	CABLING FOR EOC SURVEILLANCE SYSTEM	\$2,570.42
Remit to: RANCHO CUCAMONGA, CA					<u>FYTD:</u> \$2,570.42
MONTGOMERY PLUMBING INC	217097	05/06/2013	041513	PLUMBING SVCS-FS#48	\$127.50
Remit to: MORENO VALLEY, CA					<u>FYTD:</u> \$15,323.75
MONTGOMERY PLUMBING INC	217377	05/28/2013	051413	PLUMBING SVCS-CITY HALL	\$2,482.50
			042613	PLUMBING SVCS-CRC LADIES SHOWER ROOM	
			051013	PLUMBING SVCS-ANIMAL SHELTER	
			051313	PLUMBING SVCS-PSB GARBAGE DISPOSAL	
Remit to: MORENO VALLEY, CA					<u>FYTD:</u> \$15,323.75
MONTGOMERY, BRIDGETTE	217306	05/20/2013	5/1/13 MILEAGE	MILEAGE REIMBURSEMENT - HEALTH CARE REFORM SEMINAR	\$39.55
Remit to: YUCAIPA, CA					<u>FYTD:</u> \$39.55
MORA, PATRICIA A.	9262	05/06/2013	130501	RETIREE MEDICAL MAY '13	\$318.73
Remit to: MORENO VALLEY, CA					<u>FYTD:</u> \$3,187.30
MORENO VALLEY CHAMBER OF COMMERCE	217307	05/20/2013	3691	WAKE-UP MEETING ATTENDANCE-4/24/13	\$60.00
Remit to: MORENO VALLEY, CA					<u>FYTD:</u> \$20,570.00



**City of Moreno Valley
Payment Register
For Period 5/1/2013 through 5/31/2013**

CHECKS UNDER \$25,000

<u>Vendor Name</u>	<u>Check/EFT Number</u>	<u>Payment Date</u>	<u>Inv Number</u>	<u>Invoice Description</u>	<u>Payment Amount</u>
MORENO VALLEY CITY EMPLOYEES ASSOC.	9294	05/03/2013	2013-000000045	8710 - MVCEA EMPLOYEE DUES*	\$1,376.00
Remit to: MORENO VALLEY, CA					<u>FYTD:</u> \$33,447.00
MORENO VALLEY CITY EMPLOYEES ASSOC.	9404	05/16/2013	2013-000000077	8710 - MVCEA EMPLOYEE DUES*	\$1,371.50
Remit to: MORENO VALLEY, CA					<u>FYTD:</u> \$33,447.00
MORENO VALLEY CITY EMPLOYEES ASSOC.	9463	05/31/2013	2013-000000102	8710 - MVCEA EMPLOYEE DUES*	\$1,369.00
Remit to: MORENO VALLEY, CA					<u>FYTD:</u> \$33,447.00
MORENO VALLEY GATEWAY, LLC	9316	05/13/2013	2170	LEASE-T/S ANNEX-MAY13	\$17,142.59
			2169	LEASE-FACILITIES ANNEX-MAY13	
			2168	LEASE-SUITES 5-9/ESA ANNEX-MAY13	
Remit to: SAN JUAN CAPISTRANO, CA					<u>FYTD:</u> \$188,568.49
MORENO VALLEY GATEWAY, LLC	9437	05/28/2013	2172	LEASE-T/S ANNEX-JUNE13	\$17,142.59
			2171	LEASE-FACILITIES ANNEX-JUNE13	
			2173	LEASE-SUITES 5-9/ESA ANNEX-JUN13	
Remit to: SAN JUAN CAPISTRANO, CA					<u>FYTD:</u> \$188,568.49
MORENO VALLEY HISPANIC CHAMBER OF COMMER	217418	05/28/2013	05132013	ADELANTE MEETINGS-2/5/13 & 3/5/13	\$80.00
			5/7/13 ADELANTE	ADELANTE MEETING ATTENDANCE	
Remit to: MORENO VALLEY, CA					<u>FYTD:</u> \$7,040.00



**City of Moreno Valley
Payment Register
For Period 5/1/2013 through 5/31/2013**

CHECKS UNDER \$25,000

<u>Vendor Name</u>	<u>Check/EFT Number</u>	<u>Payment Date</u>	<u>Inv Number</u>	<u>Invoice Description</u>	<u>Payment Amount</u>
MORENO VALLEY HISPANIC CHAMBER OF COMMERCE	217436	05/28/2013	RCT#328754	REFUND-RENTAL DEPOSIT-MOBILE STAGE UNIT	\$100.00
Remit to: MORE, CA					
MORENO VALLEY UTILITY	217378	05/28/2013	7013411-01/APR13	ELECTRICITY-UTILITY FIELD OFFICE	\$99.05
Remit to: HEMET, CA					
MORENO, MARIO	217308	05/20/2013	5/28-5/30/13	TRAVEL PER DIEM-TRAINING/SOUTHERN CA. GANG CONFERENCE	\$150.00
Remit to: MORENO VALLEY, CA					
MORGAN, LISA A.	9263	05/06/2013	130501	RETIREE MEDICAL MAY '13	\$275.00
Remit to: MENTONE, CA					
MR. CLEAN MAINTENANCE SYSTEMS	217260	05/13/2013	9952	WOODFLOOR SAND AND FINISH-CRC DANCE ROOM FLOOR	\$5,400.00
Remit to: COLTON, CA					
MTGL, INC	217262	05/13/2013	0044051	CONSULTING SERVICES, GEOTECHNICAL - CITYWIDE PAVEMENT RESURFACIN	\$17,615.00
			0044050	CONSULTING SERVICES, GEOTECHNICAL - ALESSANDRO IMPROVEMENT	
			0043098	CONSULTING SERVICES, GEOTECHNICAL - SUNNYMEAD RANCH PARKWAY	
			0043099	CONSULTING SERVICES, GEOTECHNICAL - ALESSANDRO IIMPROVEMENT	
Remit to: ANAHEIM, CA					
MUSICSTAR	217309	05/20/2013	MAY-2013	INSTRUCTOR SVCS-GUITAR, MUSICSTAR KIDZ, & PIANO FOR KIDS CLASSES	\$853.20
Remit to: ANAHEIM, CA					
					FYTD: \$17,615.00



**City of Moreno Valley
Payment Register
For Period 5/1/2013 through 5/31/2013**

CHECKS UNDER \$25,000

<u>Vendor Name</u>	<u>Check/EFT Number</u>	<u>Payment Date</u>	<u>Inv Number</u>	<u>Invoice Description</u>	<u>Payment Amount</u>
Remit to: RIVERSIDE, CA				<u>FYTD:</u>	\$7,183.80
NATIONWIDE RETIREMENT SOLUTIONS CP	9296	05/03/2013	2013-00000048	8020 - DEF COMP PST - NATIONWIDE	\$2,852.30
Remit to: COLUMBUS, OH				<u>FYTD:</u>	\$675,276.51
NATIONWIDE RETIREMENT SOLUTIONS CP	9402	05/16/2013	2013-00000075	8020 - DEF COMP PST - NATIONWIDE*	\$2,543.67
Remit to: COLUMBUS, OH				<u>FYTD:</u>	\$675,276.51
NATIONWIDE RETIREMENT SOLUTIONS CP	9464	05/31/2013	2013-00000103	8020 - DEF COMP PST - NATIONWIDE*	\$2,688.56
Remit to: COLUMBUS, OH				<u>FYTD:</u>	\$675,276.51
NATIONWIDE RETIREMENT SOLUTIONS CP	9466	05/31/2013	2013-00000105	8210 - 401(A) 3% DM - NATIONWIDE*	\$1,321.58
Remit to: COLUMBUS, OH				<u>FYTD:</u>	\$675,276.51
NAVARRETTE, RALPH	9264	05/06/2013	130501	RETIREE MEDICAL MAY '13	\$146.32
Remit to: RANCHO CUCAMONGA, CA				<u>FYTD:</u>	\$1,861.55
NEIGHBORHOOD SMOKE	217232	05/13/2013	BL#23064-YR2013	REFUND OF OVERPAYMENT FOR B/L #23064	\$97.95
Remit to: MORENO VALLEY, CA				<u>FYTD:</u>	\$97.95
NELSON, MICHELE	217210	05/13/2013	5/13-5/24/13	TRAVEL PER DIEM-ICE HOMICIDE & DEATH INVESTIGATION TRNG COURSE	\$400.00
Remit to: MORENO VALLEY, CA				<u>FYTD:</u>	\$650.00
NELSON, ROBERT	9265	05/06/2013	130501	RETIREE MEDICAL MAY '13	\$255.43



**City of Moreno Valley
Payment Register
For Period 5/1/2013 through 5/31/2013**

CHECKS UNDER \$25,000

<u>Vendor Name</u>	<u>Check/EFT Number</u>	<u>Payment Date</u>	<u>Inv Number</u>	<u>Invoice Description</u>	<u>Payment Amount</u>
Remit to: ONTARIO, CA					<u>FYTD:</u> \$2,879.30
NELSON, RUTH L.	9266	05/06/2013	130501	RETIREE MEDICAL MAY '13	\$173.37
Remit to: PERRIS, CA					<u>FYTD:</u> \$1,695.90
NEUSTAEDTER, CRAIG S	217130	05/06/2013	130501	RETIREE MEDICAL MAY '13	\$318.73
Remit to: IRVINE, CA					<u>FYTD:</u> \$3,187.30
NEW HORIZON MOBILE HOME PARK	9438	05/28/2013	MARCH 2013 a	REFUND UTILITY USER TAXES FOR EXEMPT RESIDENTS	\$12.36
Remit to: LOS ANGELES, CA					<u>FYTD:</u> \$109.39
NEW WORLD SYSTEMS, CORP	9214	05/06/2013	027288	TRAVEL EXPENSES-ERP REPLACEMENT PROJECT	\$4,527.93
			027240	TRAVEL EXPENSES-ERP REPLACEMENT PROJECT	
			027461	TRAVEL EXPENSES-ERP REPLACEMENT PROJECT	
Remit to: TROY, MI					<u>FYTD:</u> \$221,972.71
NEW WORLD SYSTEMS, CORP	9317	05/13/2013	027605	TRAVEL EXPENSES-ERP REPLACEMENT PROJECT	\$2,198.84
			027537	TRAVEL EXPENSES-ERP REPLACEMENT PROJECT	
Remit to: TROY, MI					<u>FYTD:</u> \$221,972.71
NEW WORLD SYSTEMS, CORP	9439	05/28/2013	027906	TRAVEL EXPENSES-ERP REPLACEMENT PROJECT	\$1,385.60
Remit to: TROY, MI					<u>FYTD:</u> \$221,972.71
NEXUS IS, INC.	9382	05/20/2013	JC627950	CISCO SWITCHES FOR ANNEX 1	\$14,490.83
Remit to: VALENCIA, CA					<u>FYTD:</u> \$97,802.52



**City of Moreno Valley
Payment Register
For Period 5/1/2013 through 5/31/2013**

CHECKS UNDER \$25,000

<u>Vendor Name</u>	<u>Check/EFT Number</u>	<u>Payment Date</u>	<u>Inv Number</u>	<u>Invoice Description</u>	<u>Payment Amount</u>
NGUYEN, QUANG	9383	05/20/2013	MAR-APR 2013	MILEAGE REIMBURSEMENT	\$87.01
Remit to: AZUSA, CA					
NIEBURGER, JUDITH A.	217131	05/06/2013	130501	RETIREE MEDICAL MAY '13	\$401.42
Remit to: MORENO VALLEY, CA					
NINYO & MOORE GEOTECHNICAL	9440	05/28/2013	172493	CONSULTING SERVICES, GEOTECHNICAL - SR-60/MB PH I	\$20,885.75
Remit to: SAN DIEGO, CA					
NORMAN A. TRAUB ASSOCIATES	9318	05/13/2013	13036SR.1	INVESTIGATION SERVICES	\$503.55
Remit to: YORBA LINDA, CA					
OAKLEY SALES CORP	217379	05/28/2013	724056390	SAFETY EYE WEAR FOR PD MOTOR OFFICER	\$82.58
Remit to: LOS ANGELES, CA					
OASIS COMMUNITY CHURCH	217323	05/20/2013	P10-020	RELEASE OF GRADING AND EROSION CONTROL DEPOSIT	\$7,900.00
Remit to: MORENO VALLEY, CA					
OLEGREUT	217326	05/20/2013	PA13-0010	80% REFUND FOR WITHDRAWN PLANNING APPLICATION	\$2,428.80
Remit to: TARZANA, CA					
OPTUS, INC	217284	05/20/2013	TQ1191265	NEC IP SIP D-TERM TELEPHONES	\$3,900.96
Remit to: JONESBORO, AZ					
ORIGINAL SUNNYMEAD BURGERS	217235	05/13/2013	BL#17890-YR2013	REFUND OF OVERPAYMENT FOR B/L #17890	\$92.00
Remit to: MORENO VALLEY, CA					



**City of Moreno Valley
Payment Register
For Period 5/1/2013 through 5/31/2013**

CHECKS UNDER \$25,000

<u>Vendor Name</u>	<u>Check/EFT Number</u>	<u>Payment Date</u>	<u>Inv Number</u>	<u>Invoice Description</u>	<u>Payment Amount</u>
ORROCK, POPKA, FORTINO & BRISLIN	9319	05/13/2013	90-035Z STMT 6	LEGAL DEFENSE COSTS - V. GOODWIN	\$72.00
Remit to: RIVERSIDE, CA					<u>FYTD:</u> \$16,243.13
ORROCK, POPKA, FORTINO & BRISLIN	9384	05/20/2013	90-035M STMT 5	LEGAL DEFENSE COSTS - V. GOODWIN	\$1,692.00
			90-036M STMT 1	LEGAL DEFENSE COSTS - P. O'DANE CLAIM	
			90-036M STMT 2	LEGAL DEFENSE COSTS - P. O'DANE CLAIM	
Remit to: RIVERSIDE, CA					<u>FYTD:</u> \$16,243.13
PACIFIC SAFETY CENTER	9320	05/13/2013	69482	CONFINED SPACE TRAINING CLASS - 12/6/12	\$1,950.00
Remit to: SAN DIEGO, CA					<u>FYTD:</u> \$1,950.00
PACIFIC TELEMANAGEMENT SERVICES	9321	05/13/2013	523833	PAYPHONE SERVICES	\$313.20
			523833 a	PAYPHONE SERVICES	
Remit to: SAN RAMON, CA					<u>FYTD:</u> \$3,507.84
PAINTING BY ZEB BODE	9322	05/13/2013	132804	PAINTING OF ABOVE GROUND FUEL STORAGE TANKS-FIRE ST.# 2, 48 & 91	\$2,600.00
Remit to: NORCO, CA					<u>FYTD:</u> \$45,663.00
PARADIGM ENERGY CONSULTING	9385	05/20/2013	MVU-04-2013	CONSULTING SERVICES RE: MV UTILITY 10-YR RESOURCE PLAN	\$1,400.00
Remit to: SACRAMENTO, CA					<u>FYTD:</u> \$17,200.00
PATTERSON, ALFREY	217132	05/06/2013	130501	RETIREE MEDICAL MAY '13	\$146.32
Remit to: MORENO VALLEY, CA					<u>FYTD:</u> \$1,861.55



**City of Moreno Valley
Payment Register
For Period 5/1/2013 through 5/31/2013**

CHECKS UNDER \$25,000

<u>Vendor Name</u>	<u>Check/EFT Number</u>	<u>Payment Date</u>	<u>Inv Number</u>	<u>Invoice Description</u>	<u>Payment Amount</u>
PEDLEY SQUARE VETERINARY CLINIC	9442	05/28/2013	MAR-2013	VETERINARY SERVICES FOR MV ANIMAL SHELTER	\$9,593.00
Remit to: RIVERSIDE, CA					<u>FYTD:</u> \$67,278.25
PERRY, NORMA	9267	05/06/2013	130501	RETIREE MEDICAL MAY '13	\$318.73
Remit to: LOCKEFORD, CA					<u>FYTD:</u> \$3,187.30
PERS LONG TERM CARE PROGRAM	217098	05/06/2013	2013-00000054	4720 - PERS LONG TERM CARE	\$458.63
Remit to: PASADENA, CA					<u>FYTD:</u> \$10,548.49
PERS LONG TERM CARE PROGRAM	217285	05/20/2013	2013-00000084	4720 - PERS LONG TERM CARE	\$458.63
Remit to: PASADENA, CA					<u>FYTD:</u> \$10,548.49
PERS RETIREMENT	9362	05/07/2013	P130412b	PERS RETIREMENT CLASSIC	\$465.72
Remit to: SACRAMENTO, CA					<u>FYTD:</u> \$5,596,057.52
PERS RETIREMENT	9407	05/10/2013	P130426a	PERS RETIREMENT - CLASSIC	\$9,014.19
Remit to: SACRAMENTO, CA					<u>FYTD:</u> \$5,596,057.52
PERS RETIREMENT	9408	05/10/2013	P130426b	PERS RETIREMENT - PEPPRA	\$1,623.15
Remit to: SACRAMENTO, CA					<u>FYTD:</u> \$5,596,057.52
PIP PRINTING	9443	05/28/2013	53691	POSTCARD PRINTING WITH MAILING SERVICES	\$3,301.21
Remit to: MORENO VALLEY, CA					<u>FYTD:</u> \$10,449.25
POUNDS, NANCY	9268	05/06/2013	130501	APR '13, PD MAY '13	\$318.73



**City of Moreno Valley
Payment Register
For Period 5/1/2013 through 5/31/2013**

CHECKS UNDER \$25,000

<u>Vendor Name</u>	<u>Check/EFT Number</u>	<u>Payment Date</u>	<u>Inv Number</u>	<u>Invoice Description</u>	<u>Payment Amount</u>
Remit to: BOISE, ID				<u>FYTD:</u>	\$2,868.57
PRETZELMAKER	217239	05/13/2013	BL#22776-YR2013	REFUND OF OVERPAYMENT FOR B/L #22776	\$80.28
Remit to: MORENO VALLEY, CA				<u>FYTD:</u>	\$80.28
PRICE, GEORGE E.	9269	05/06/2013	130501	RETIREE MEDICAL MAY '13	\$318.73
Remit to: MORENO VALLEY, CA				<u>FYTD:</u>	\$3,187.30
PROFESSIONAL COMMUNICATIONS NETWORK PCN	217380	05/28/2013	130500452	LIVE ANSWERING SERVICE FOR TOW PROGRAM	\$1,063.45
Remit to: RIVERSIDE, CA				<u>FYTD:</u>	\$6,024.45
PULLIAM, TRENT D.	9270	05/06/2013	130501	RETIREE MEDICAL MAY '13	\$318.73
Remit to: MISSION VIEJO, CA				<u>FYTD:</u>	\$3,187.30
PYRO SPECTACULARS, INC.	217383	05/28/2013	50271	DEPOSIT FOR JULY 4, 2013 FIREWORKS DISPLAY	\$15,000.00
Remit to: RIALTO, CA				<u>FYTD:</u>	\$30,000.00
QUALITY BOOKS, INC.	217099	05/06/2013	169284	CHILDREN'S ENGLISH LANGUAGE SRP BOOKS FOR LIBRARY	\$631.46
Remit to: OREGON, IL				<u>FYTD:</u>	\$631.46
QUALITY CODE PUBLISHING, LLC	9323	05/13/2013	2013-152	SUPPLEMENT SERVICE TO THE MV MUNICIPAL CODE	\$1,604.32
Remit to: SEATTLE, WA				<u>FYTD:</u>	\$4,720.95
RAINBOW BOOK COMPANY	217100	05/06/2013	0101878	ENGLISH LANGUAGE CHILDREN'S BOOKS FOR LIBRARY	\$2,946.41



**City of Moreno Valley
Payment Register
For Period 5/1/2013 through 5/31/2013**

CHECKS UNDER \$25,000

<u>Vendor Name</u>	<u>Check/EFT Number</u>	<u>Payment Date</u>	<u>Inv Number</u>	<u>Invoice Description</u>	<u>Payment Amount</u>
RAINBOW BOOK COMPANY	217100	05/06/2013	0101879	SPANISH LANGUAGE CHILDREN'S BOOKS FOR LIBRARY	\$2,946.41
Remit to: LAKE ZURICH, IL					
RAQUEL CERVANTES	217220	05/13/2013	R13-059476	AS REFUND-RABIES DEPOSIT	\$20.00
Remit to: MORENO VALLEY, CA					
RASMUSSEN BROTHERS CONSTRUCTION	217286	05/20/2013	MVPD MR 3 Ret	CONSTRUCTION CONTRACT - MVPD MONITOR ROOM	\$10,200.05
MVPD 4 Retention					
CONSTRUCTION CONTRACT - MVPD TRAFFIC DIV. OFFICE					
Remit to: FALLBROOK, CA					
RAY VASQUES CERAMIC TILE CONTRACTOR	217441	05/28/2013	BL#15242-YR2013	REFUND OF OVERPAYMENT FOR BL#15242	\$54.00
Remit to: MORENO VALLEY, CA					
RAY-RAMIREZ, DARCY L.	217133	05/06/2013	130501	RETIREE MEDICAL MAY '13	\$318.73
Remit to: RIVERSIDE, CA					
RAYS BARBER & BEAUTY SALON	217325	05/20/2013	BL#05552-YR2013	REFUND OF OVERPAYMENT FOR BL#05552	\$60.50
Remit to: MORENO VALLEY, CA					
RBF CONSULTING, INC.	9444	05/28/2013	847504	CONSULTING SVCS-IS/MND FOR ALESSANDRO BLVD CORRIDOR IMPLEMENTAT.	\$6,158.50
842612					
CONSULTING SERVICES, ENGINEERING - CACTUS/NASON					
Remit to: IRVINE, CA					
RDO EQUIPMENT CO, INC	217101	05/06/2013	P51472	FRONT DIFFERENTIAL ASSEMBLY & PLUG FOR BACKHOE	\$8,598.28
Remit to: IRVINE, CA					
					FYTD: \$90,536.38



**City of Moreno Valley
Payment Register
For Period 5/1/2013 through 5/31/2013**

CHECKS UNDER \$25,000

<u>Vendor Name</u>	<u>Check/EFT Number</u>	<u>Payment Date</u>	<u>Inv Number</u>	<u>Invoice Description</u>	<u>Payment Amount</u>
Remit to: RIVERSIDE, CA					<u>FYTD:</u> \$8,598.28
REEIS CA, INC	217442	05/28/2013	BL#26211-YR2013	REFUND OF OVERPAYMENT FOR BL#26211	\$73.74
Remit to: RIVERSIDE, CA					<u>FYTD:</u> \$73.74
Regina Yanez	217255	05/13/2013	493872	REFUND PICNIC SHELTER	\$37.00
Remit to: MORENO VALLEY, CA					<u>FYTD:</u> \$37.00
REPUBLIC MASTER CHEFS TEXTILE RENTAL SERVICE	9325	05/13/2013	10961174	LINEN RENTAL FOR CRC	\$25.00
Remit to: LOS ANGELES, CA					<u>FYTD:</u> \$1,670.43
REPUBLIC MASTER CHEFS TEXTILE RENTAL SERVICE	9386	05/20/2013	10892047	LINEN RENTAL FOR CRC	\$260.82
			10967913	LINEN RENTAL FOR CRC	
			S220571	LINENS FOR SPECIAL EVENTS AT CRC	
			10898400	LINEN RENTAL FOR CRC	
			10973878	LINEN RENTAL FOR CRC	
			S197511	LINENS FOR SPECIAL EVENTS AT CRC	
			10809921	LINEN RENTAL FOR CRC	
			10879365	LINEN RENTAL FOR CRC	
			10854952	LINEN RENTAL FOR CRC	
Remit to: LOS ANGELES, CA					<u>FYTD:</u> \$1,670.43
REPUBLIC MASTER CHEFS TEXTILE RENTAL SERVICE	9445	05/28/2013	10979822	LINEN RENTAL FOR CRC	\$89.00
			S224315	LINENS FOR SPECIAL EVENTS AT CRC	



City of Moreno Valley
Payment Register
 For Period 5/1/2013 through 5/31/2013

CHECKS UNDER \$25,000

<u>Vendor Name</u>	<u>Check/EFT Number</u>	<u>Payment Date</u>	<u>Inv Number</u>	<u>Invoice Description</u>	<u>Payment Amount</u>
Remit to: LOS ANGELES, CA				<u>FYTD:</u>	\$1,670.43
RHA LANDSCAPE ARCHITECTS-PLANNERS	217385	05/28/2013	0413024	SHADOW MOUNTAIN PARK RAMP MODIFICATION DESIGN SERVICES	\$1,600.00
Remit to: RIVERSIDE, CA				<u>FYTD:</u>	\$3,430.00
RICHARD DIXON	217310	05/20/2013	5/28-5/30/13	TRAVEL PER DIEM-TRAINING/SOUTHERN CA. GANG CONFERENCE	\$150.00
Remit to: MORENO VALLEY, CA				<u>FYTD:</u>	\$325.00
RICHARD YOUNG	217313	05/20/2013	304	GOLD RUSH COUNTRY BAND-5/31/13 CONCERT AT TOWNGATE PARK	\$1,500.00
Remit to: LOS ANGELES, CA				<u>FYTD:</u>	\$1,500.00
RICK HARTMANN	217125	05/06/2013	130501	RETIREE MEDICAL MAY '13	\$318.73
Remit to: SAN DIMAS, CA				<u>FYTD:</u>	\$2,549.84
RIGHTWAY SITE SERVICES, INC.	217287	05/20/2013	723368	PORTABLE RESTROOM-COTTONWOOD GOLF COURSE	\$476.34
			723458	PORTABLE TOILET ON WHEELS/SERVICE FOR M&O DIV.	
			723369	PORTABLE RESTROOMS-EQUESTRIAN CENTER	
Remit to: LAKE ELSINORE, CA				<u>FYTD:</u>	\$5,672.51
RIVERSIDE COUNTY INFORMATION TECHNOLOGY (RCIT)	217102	05/06/2013	9990023000-1303	800-MHZ RADIO MONTHLY LEASE	\$189.90
Remit to: RIVERSIDE, CA				<u>FYTD:</u>	\$23,680.07
RIVERSIDE COUNTY SHERIFF CIVIL DIVISION-WEST	217103	05/06/2013	2013-00000055	1015 - GARNISHMENT - CREDITOR %	\$158.43



**City of Moreno Valley
Payment Register
For Period 5/1/2013 through 5/31/2013**

CHECKS UNDER \$25,000

<u>Vendor Name</u>	<u>Check/EFT Number</u>	<u>Payment Date</u>	<u>Inv Number</u>	<u>Invoice Description</u>	<u>Payment Amount</u>
Remit to: RIVERSIDE, CA					<u>FYTD:</u> \$6,035.82
RIVERSIDE COUNTY SHERIFF CIVIL DIVISION-WEST	217288	05/20/2013	2013-00000085	1015 - GARNISHMENT - CREDITOR %	\$156.56
Remit to: RIVERSIDE, CA					<u>FYTD:</u> \$6,035.82
RLZ ENGINEERING	9216	05/06/2013	413	CONSULTING SERVICES, ENGINEERING	\$5,812.50
Remit to: CORONA, CA					<u>FYTD:</u> \$5,812.50
RODERICK AND ASSOCIATES PROPERTY MANAGEMENT	217240	05/13/2013	BL#16760-YR2013	REFUND OF OVERPAYMENT FOR B/L #16760	\$74.26
Remit to: MORENO VALLEY, CA					<u>FYTD:</u> \$74.26
ROGERS, EUGENE	9271	05/06/2013	130501	RETIREE MEDICAL MAY '13	\$318.73
Remit to: PEBBLE BEACH, CA					<u>FYTD:</u> \$3,187.30
RONALD GONZALES	217224	05/13/2013	R13-061316	AS REFUND-TRAP DEPOSIT	\$50.00
Remit to: RIVERSIDE, CA					<u>FYTD:</u> \$50.00
ROSA ORELLANA	217165	05/06/2013	1036469	REFUNDS FOR RENTALS	\$200.00
Remit to: MORENO VALLEY, CA					<u>FYTD:</u> \$200.00
ROSE GONZALEZ	217341	05/20/2013	MV3130314005	REFUND-CITATION OVERPAYMENT	\$57.50
Remit to: OXNARD, CA					<u>FYTD:</u> \$57.50
ROSS, DAVID T.	9272	05/06/2013	130501	RETIREE MEDICAL MAY '13	\$318.73
Remit to: MORENO VALLEY, CA					<u>FYTD:</u> \$3,187.30



**City of Moreno Valley
Payment Register
For Period 5/1/2013 through 5/31/2013**

CHECKS UNDER \$25,000

<u>Vendor Name</u>	<u>Check/EFT Number</u>	<u>Payment Date</u>	<u>Inv Number</u>	<u>Invoice Description</u>	<u>Payment Amount</u>
ROSSON, LOUIS A.	9341	05/13/2013	130501A	MAY '13 RETIREE MED REIMBURSEMENT	\$269.87
			130501	MAY '13 RETIREE MED REIMBURSEMENT	
Remit to: PERRIS, CA					<u>FYTD:</u> \$2,749.84
ROTO-ROOTER PLUMBERS	9326	05/13/2013	IE242258	PLUMBING REPAIR-MAIN LINE CLEARED AT WESTON PARK	\$205.00
Remit to: RANCHO CUCAMONGA, CA					<u>FYTD:</u> \$929.23
ROTO-ROOTER PLUMBERS	9387	05/20/2013	IE242267	PLUMBING REPAIR-2" LINES CLEARED AT MORRISON PARK	\$160.87
Remit to: RANCHO CUCAMONGA, CA					<u>FYTD:</u> \$929.23
RUDY MOLINA	217163	05/06/2013	1036422	REFUNDS FOR RENTALS	\$750.00
Remit to: MORENO VALLEY, CA					<u>FYTD:</u> \$750.00
RUSO, JOHN	9273	05/06/2013	130501	RETIREE MEDICAL MAY '13	\$146.32
Remit to: RANCHO MIRAGE, CA					<u>FYTD:</u> \$1,861.55
RUTH CASALES	217153	05/06/2013	R12-056984	AS REFUND-RABIES DEPOSIT	\$20.00
Remit to: MORENO VALLEY, CA					<u>FYTD:</u> \$20.00
SA ASSOCIATES	9217	05/06/2013	79	CONSULTING SERVICES, ENGINEERING	\$4,350.00
Remit to: ARCADIA, CA					<u>FYTD:</u> \$107,775.00
SABRE LIGHTING AND SIGNS	217193	05/13/2013	5231	VINYL LETTERING FOR VARIOUS DOOR SIGNAGE AT ANNEX 1	\$130.00
Remit to: MORENO VALLEY, CA					<u>FYTD:</u> \$6,578.70
SABRE LIGHTING AND SIGNS	217289	05/20/2013	5230	MV ELECTRIC UTILITY SIGN FOR NEW BLDG.-LETTERS, LOGO & INSTALL	\$1,147.91



City of Moreno Valley
Payment Register
 For Period 5/1/2013 through 5/31/2013

CHECKS UNDER \$25,000

<u>Vendor Name</u>	<u>Check/EFT Number</u>	<u>Payment Date</u>	<u>Inv Number</u>	<u>Invoice Description</u>	<u>Payment Amount</u>
Remit to: MORENO VALLEY, CA					<u>FYTD:</u> \$6,578.70
SAFEWAY SIGN CO.	9388	05/20/2013	93686	TRAFFIC SIGNS, POSTS, HARDWARE	\$267.30
Remit to: ADELANTO, CA					<u>FYTD:</u> \$20,141.63
Sanath Sirwardena	217245	05/13/2013	493950	REFUND GUITAR CLASS CANCELLED	\$61.00
Remit to: MORENO VALLEY, CA					<u>FYTD:</u> \$61.00
SANDRA THER	217445	05/28/2013	R13-059258	AS REFUND-RABIES DEPOSIT	\$20.00
Remit to: MORENO VALLEY, CA					<u>FYTD:</u> \$20.00
SANDRA JO GIL	217340	05/20/2013	MV4130325015	REFUND-CITATION OVERPAYMENT	\$57.50
Remit to: MORENO VALLEY, CA					<u>FYTD:</u> \$57.50
SARAH HAYES	217158	05/06/2013	1034817	REFUND FOR TOWNGATE DEPOSIT	\$200.00
Remit to: MORENO VALLEY, CA					<u>FYTD:</u> \$200.00
SARAH ORTIZ	217324	05/20/2013	R13-061851	AS REFUND-RABIES DEPOSIT	\$20.00
Remit to: MENIFEE, CA					<u>FYTD:</u> \$20.00
SCHIEFELBEIN, LORI C.	217134	05/06/2013	130501	APR '13, PD MAY '13	\$318.73
Remit to: BULLHEAD CITY, AZ					<u>FYTD:</u> \$16,552.30
SCHIEFELBEIN, LORI C.	217386	05/28/2013	APR 2013	CONSULTANT SVCS-ROTATIONAL TOW PROGRAM	\$1,058.75
Remit to: BULLHEAD CITY, AZ					<u>FYTD:</u> \$16,552.30
SCHUMAN, MICHAEL	9274	05/06/2013	130501	RETIREE MEDICAL MAY '13	\$318.73



**City of Moreno Valley
Payment Register
For Period 5/1/2013 through 5/31/2013**

CHECKS UNDER \$25,000

<u>Vendor Name</u>	<u>Check/EFT Number</u>	<u>Payment Date</u>	<u>Inv Number</u>	<u>Invoice Description</u>	<u>Payment Amount</u>
Remit to: RIVERSIDE, CA					<u>FYTD:</u> \$3,187.30
SCMAF - INLAND VALLEY	217104	05/06/2013	2013-7	YOUTH BASKETBALL ENTRY FEES	\$525.00
Remit to: EL MONTE, CA					<u>FYTD:</u> \$790.00
SCMAF - INLAND VALLEY	217194	05/13/2013	1355	2013 YOUTH BASKETBALL FINALS FEES	\$125.00
Remit to: EL MONTE, CA					<u>FYTD:</u> \$790.00
SECTRAN SECURITY, INC	217290	05/20/2013	13050632 - ENT	ARMORED TRANSPORT SERVICES-MV UTILITY	\$477.00
			13050632 - CH	ARMORED TRANSPORT SERVICES-CITY HALL	
			13050632 - PR	ARMORED TRANSPORT SERVICES-PARKS & COMM. SVCS	
Remit to: LOS ANGELES, CA					<u>FYTD:</u> \$5,247.00
SECURITY AND COMMUNICATIONS CONSULTING	9389	05/20/2013	03113	CONSULTING SVCS-CITYWIDE CAMERA SURVEILLANCE SYSTEM/MAR. 2013	\$11,677.60
Remit to: CLOVIS, CA					<u>FYTD:</u> \$62,052.40
SECURITY LOCK & KEY	9327	05/13/2013	25672	LOCK CYLINDER CHANGE & DUPLICATE KEYS	\$69.27
Remit to: YUCAIPA, CA					<u>FYTD:</u> \$15,635.04
SECURITY LOCK & KEY	9390	05/20/2013	25900	REPAIR OF LOCK ON FIRE SAFE CABINETS-WO#13-0595	\$93.42
Remit to: YUCAIPA, CA					<u>FYTD:</u> \$15,635.04
SHALANA GREY	217156	05/06/2013	R13-060176	AS REFUND-SPAY/NEUTER DEPOSIT	\$75.00
Remit to: HAWTHORNE, CA					<u>FYTD:</u> \$75.00
SHARON GREY	217157	05/06/2013	R13-060180	AS REFUND-SPAY/NEUTER DEPOSIT	\$75.00



**City of Moreno Valley
Payment Register
For Period 5/1/2013 through 5/31/2013**

CHECKS UNDER \$25,000

<u>Vendor Name</u>	<u>Check/EFT Number</u>	<u>Payment Date</u>	<u>Inv Number</u>	<u>Invoice Description</u>	<u>Payment Amount</u>
Remit to: MORENO VALLEY, CA					<u>FYTD:</u> \$75.00
SHARRETT, SHARON K.	9275	05/06/2013	130501	RETIREE MEDICAL MAY '13	\$173.37
Remit to: ONTARIO, CA					<u>FYTD:</u> \$1,695.90
SHAWNA HAMON	217321	05/20/2013	R13-061019	AS REFUND-SPAY/NEUTER DEPOSIT	\$75.00
Remit to: RIVERSIDE, CA					<u>FYTD:</u> \$75.00
SHEILA BAGGETT	217334	05/20/2013	MV3130326027	REFUND-CITATION OVERPAYMENT	\$18.00
Remit to: MORENO VALLEY, CA					<u>FYTD:</u> \$18.00
SHELDON, STUART H.	217135	05/06/2013	130501	RETIREE MEDICAL MAY '13	\$318.73
Remit to: MURRIETA, CA					<u>FYTD:</u> \$3,187.30
SHELL OIL CO.	217387	05/28/2013	065124489305	FUEL PURCHASES-PD MOTORCYCLES	\$1,894.50
Remit to: COLUMBUS, OH					<u>FYTD:</u> \$20,413.06
SHERRI MILLIGAN	217434	05/28/2013	1037598	REFUND - CANCELLATION BY CLIENT	\$29.60
Remit to: MORENO VALLEY, CA					<u>FYTD:</u> \$29.60
SILICON FORENSICS, INC	217452	05/28/2013	101872	FORENSIC COMPUTER WORKSTATION	\$4,638.60
Remit to: POMONA, CA					<u>FYTD:</u> \$4,638.60
SILVERIA GARCIA	217339	05/20/2013	MV99478	REFUND-CITATION OVERPAYMENT	\$407.50
Remit to: MORENO VALLEY, CA					<u>FYTD:</u> \$407.50
SKECHERS	217327	05/20/2013	7013669-01/APR13	SOLAR INCENTIVE REBATE	\$6,207.65



**City of Moreno Valley
Payment Register
For Period 5/1/2013 through 5/31/2013**

CHECKS UNDER \$25,000

<u>Vendor Name</u>	<u>Check/EFT Number</u>	<u>Payment Date</u>	<u>Inv Number</u>	<u>Invoice Description</u>	<u>Payment Amount</u>
Remit to: MORENO VALLEY, CA					<u>FYTD:</u> \$6,207.65
SKY PUBLISHING	217105	05/06/2013	13_3_318	1/2 PAGE SHOP MOVAL ADVERTISEMENT/MAY 2-4 ISSUE	\$857.00
Remit to: MORENO VALLEY, CA					<u>FYTD:</u> \$59,519.00
SKY PUBLISHING	217195	05/13/2013	13_3_145	FULL PAGE AD FOR USED OIL FILTER RECYCLING & EXCHANGE EVENT	\$2,325.00
			13_3_146	1/2 PAGE AD FOR USED OIL RECYCLING LOCATIONS	
Remit to: MORENO VALLEY, CA					<u>FYTD:</u> \$59,519.00
SKY TRAILS MOBILE VILLAGE	9446	05/28/2013	APRIL 2013	REFUND UTILITY USER TAXES FOR EXEMPT RESIDENTS	\$47.40
Remit to: LOS ANGELES, CA					<u>FYTD:</u> \$465.38
SLAGERMAN, SUSAN A.	9276	05/06/2013	130501	MAR '13, PD MAY '13	\$318.73
Remit to: MORENO VALLEY, CA					<u>FYTD:</u> \$2,868.57
SMITH, MARIA A.	9277	05/06/2013	130501	RETIREE MEDICAL MAY '13	\$318.73
Remit to: MORENO VALLEY, CA					<u>FYTD:</u> \$3,187.30
SOCO GROUP, INC	9218	05/06/2013	692814	FUEL FOR CITY VEHICLES & EQUIPMENT	\$15,764.99
			693506	FUEL FOR CITY VEHICLES & EQUIPMENT	
Remit to: PERRIS, CA					<u>FYTD:</u> \$317,670.41
SOSA, HUGO	9457	05/28/2013	MAY-2013	INSTRUCTOR SVCS-TRADITIONAL KARATEDO CLASS	\$270.00
Remit to: ELK GROVE, CA					<u>FYTD:</u> \$1,380.00
SOSA, HUGO	217261	05/13/2013	FEB-2013	INSTRUCTOR SVCS-TRADITIONAL KARATEDO CLASS	\$420.00



**City of Moreno Valley
Payment Register
For Period 5/1/2013 through 5/31/2013**

CHECKS UNDER \$25,000

<u>Vendor Name</u>	<u>Check/EFT Number</u>	<u>Payment Date</u>	<u>Inv Number</u>	<u>Invoice Description</u>	<u>Payment Amount</u>
SOSA, HUGO	217261	05/13/2013	MAR-2013	INSTRUCTOR SVCS-TRADITIONAL KARATEDO CLASS	\$420.00
			APR-2013	INSTRUCTOR SVCS-TRADITIONAL KARATEDO CLASS	
Remit to: ELK GROVE, CA					<u>FYTD:</u> \$1,380.00
SOUTH COAST AIR QUALITY MGMT DISTRICT	217388	05/28/2013	2595776	AQMD "HOT SPOTS" PROGRAM FEE-JULY 2012 TO JUNE 2013	\$116.61
Remit to: DIAMOND BAR, CA					<u>FYTD:</u> \$3,879.54
SOUTH COAST AIR QUALITY MGMT DISTRICT	217421	05/28/2013	FORM 222-B	APPLICATION FOR RULE 222 - BOILER/HEATER	\$173.56
Remit to: DIAMOND BAR, CA					<u>FYTD:</u> \$3,879.54
SOUTHBOUND AND COMPANY	217148	05/06/2013	320	SOUTHBOUND AND COMPANY BAND-5/17/13 CONCERT AT TOWNGATE PARK	\$1,000.00
Remit to: RIVERSIDE, CA					<u>FYTD:</u> \$1,000.00
SOUTHERN CALIFORNIA EDISON 1	217106	05/06/2013	APR-13 5/6/13	ELECTRICITY	\$5,424.75
Remit to: ROSEMEAD, CA					<u>FYTD:</u> \$2,913,589.27
SOUTHERN CALIFORNIA EDISON 1	217196	05/13/2013	APR-13 5/13/13	ELECTRICITY	\$19,644.07
Remit to: ROSEMEAD, CA					<u>FYTD:</u> \$2,913,589.27
SOUTHERN CALIFORNIA EDISON 1	217292	05/20/2013	7500265388	RELIABILITY SERVICE-DLAP_SCE_SEES_HV	\$216.86
Remit to: ROSEMEAD, CA					<u>FYTD:</u> \$2,913,589.27
SOUTHERN CALIFORNIA EDISON 1	217389	05/28/2013	APR-13 5/28/13	ELECTRICITY	\$16,677.87
			MAY-13 5/28/13	ELECTRICITY	



**City of Moreno Valley
Payment Register
For Period 5/1/2013 through 5/31/2013**

CHECKS UNDER \$25,000

<u>Vendor Name</u>	<u>Check/EFT Number</u>	<u>Payment Date</u>	<u>Inv Number</u>	<u>Invoice Description</u>	<u>Payment Amount</u>
Remit to: ROSEMEAD, CA					<u>FYTD:</u> \$2,913,589.27
SOUTHERN CALIFORNIA GAS CO.	217293	05/20/2013	APR-2013	GAS CHARGES	\$4,227.10
Remit to: MONTEREY PARK, CA					<u>FYTD:</u> \$59,146.79
SOUTHERN CALIFORNIA GAS CO.	217390	05/28/2013	17826018594 5/20	GAS CHARGES-ANNEX BLDG 1	\$146.19
Remit to: MONTEREY PARK, CA					<u>FYTD:</u> \$59,146.79
SPARKLETTTS	217197	05/13/2013	7364551 042313	BOTTLED WATER/SVC-SUNNYMEAD ELEMENTARY "A CHILDS PLACE"	\$16.29
Remit to: DALLAS, TX					<u>FYTD:</u> \$1,092.05
SPARKLETTTS	217294	05/20/2013	7364596 050213	BOTTLED WATER/SVC-CREEKSIDE ELEMENTARY "A CHILDS PLACE"	\$41.14
			7363683 050213	BOTTLED WATER/SVC-ARMADA ELEMENTARY "A CHILDS PLACE"	
Remit to: DALLAS, TX					<u>FYTD:</u> \$1,092.05
SPARKLETTTS	217391	05/28/2013	7387294 050713	BOTTLED WATER/SVC-COTTONWOOD GOLF COURSE	\$5.00
Remit to: DALLAS, TX					<u>FYTD:</u> \$1,092.05
SPECK, GARY B.	9278	05/06/2013	130501	RETIREE MEDICAL MAY '13	\$318.73
Remit to: MORENO VALLEY, CA					<u>FYTD:</u> \$3,187.30
SPENCER, MARTHA	9279	05/06/2013	130501	RETIREE MEDICAL MAY '13	\$146.32
Remit to: MORENO VALLEY, CA					<u>FYTD:</u> \$1,861.55
SPRINT	9447	05/28/2013	634235346-032	CELLULAR PHONE SVC FOR PD SET	\$864.73
			417544340-077	CELLULAR PHONE SVC FOR PD GTF	



**City of Moreno Valley
Payment Register
For Period 5/1/2013 through 5/31/2013**

CHECKS UNDER \$25,000

<u>Vendor Name</u>	<u>Check/EFT Number</u>	<u>Payment Date</u>	<u>Inv Number</u>	<u>Invoice Description</u>	<u>Payment Amount</u>
Remit to: CAROL STREAM, IL					
SPRINT	217392	05/28/2013	LCI-158580	CELLULAR TECH EXTRACTION & LOCATOR SVCS	\$8,687.74
			LCI-168800	CELLULAR TECH EXTRACTION & LOCATOR SVCS	\$500.00
			LCI-170343	CELLULAR TECH EXTRACTION & LOCATOR SVCS	
Remit to: KANSAS CITY, MO					
STA STUDENT TRANSPORTATION OF AMERICA	217198	05/13/2013	5433074	BUS SERVICE FOR "A CHILD'S PLACE" FIELD TRIP	\$208.69
Remit to: GOLETA, CA					
STANDARD INSURANCE CO	217149	05/06/2013	130501	SUPPLEMENTAL INSURANCE	\$8,663.89
Remit to: PORTLAND, OR					
STANLEY CONVERGENT SECURITY SOLUTIONS, INC	9328	05/13/2013	9962964	ALARM SYSTEM MONITORING SVCS-FIRE ST. #58	\$958.07
			10115460	SECURITY SYSTEM MONITORING-PARKS SNACK BARS	
			10087786	ADDITION TO INTRUSION ALARM SYSTEM AT ANNEX 1 BLDG.	
Remit to: PALATINE, IL					
STANLEY CONVERGENT SECURITY SOLUTIONS, INC	9391	05/20/2013	10151655	ANIMAL SHELTER FIRE ALARM ZONE 22 SERVICE/BATTERY REPLACED	\$1,181.95
			10074737	ALARM SYSTEM AT CRC-REPLACED 4 BATTERIES & 1 12V-7AMP BATTERY	
Remit to: PALATINE, IL					
STANLEY CONVERGENT SECURITY SOLUTIONS, INC	9448	05/28/2013	10103680	SECURITY SYSTEM MONITORING-MORRISON PARK SNACK BAR	\$1,990.38
					\$48,563.98



**City of Moreno Valley
Payment Register
For Period 5/1/2013 through 5/31/2013**

CHECKS UNDER \$25,000

<u>Vendor Name</u>	<u>Check/EFT Number</u>	<u>Payment Date</u>	<u>Inv Number</u>	<u>Invoice Description</u>	<u>Payment Amount</u>
STANLEY CONVERGENT SECURITY SOLUTIONS, INC	9448	05/28/2013	10105295	ALARM SYSTEM MONITORING SVCS-COTTONWOOD GOLF COURSE	\$1,990.38
			10197511	SECURITY SYSTEM MONITORING-SUNNYMEAD/BETHUNE PARKS SNACK BARS	
			10192349	ALARM SYSTEM MONITORING SVCS-EOC	
			10137884	ALARM SYSTEM MONITORING SVCS-CITY HALL	
			10134689	ALARM SYSTEM MONITORING SVCS-LIBRARY	
			9982612	REPAIRS TO MOTION SENSOR-ZONE 9 AT GOLF COURSE WO#12-0251	
			10117154	ALARM SYSTEM MONITORING SVCS-RED MAPLE FOR "A CHILD'S PLACE"	
Remit to: PALATINE, IL					<u>FYTD:</u> \$48,563.98
STARLETTA SUTTON	217443	05/28/2013	CK#2079	REISSUE UNCLAIMED CK#2079 DTD 5/6/09	\$170.19
Remit to: ALTADENA, CA					<u>FYTD:</u> \$170.19
STATE BOARD OF EQUALIZATION	9411	05/23/2013	043013	SALES & USE TAX FOR THE PERIOD 4/1-4/30/13	\$2,713.00
1					
Remit to: SACRAMENTO, CA					<u>FYTD:</u> \$23,529.12
STATE DISBURSEMENT UNIT	9295	05/03/2013	2013-00000047	1005 - GARNISHMENT - CHILD SUPPORT*	\$1,882.76
Remit to: WEST SACRAMENTO, CA					<u>FYTD:</u> \$53,004.25
STATE DISBURSEMENT UNIT	9401	05/16/2013	2013-00000074	1005 - GARNISHMENT - CHILD SUPPORT*	\$1,940.79
Remit to: WEST SACRAMENTO, CA					<u>FYTD:</u> \$53,004.25
STATE DISBURSEMENT UNIT	9465	05/31/2013	2013-00000104	1005 - GARNISHMENT - CHILD SUPPORT*	\$1,964.97



**City of Moreno Valley
Payment Register
For Period 5/1/2013 through 5/31/2013**

CHECKS UNDER \$25,000

<u>Vendor Name</u>	<u>Check/EFT Number</u>	<u>Payment Date</u>	<u>Inv Number</u>	<u>Invoice Description</u>	<u>Payment Amount</u>
Remit to: WEST SACRAMENTO, CA					<u>FYTD:</u> \$53,004.25
STATE OF CALIFORNIA DEPT. OF JUSTICE	217108	05/06/2013	937971 (PCS)	FINGERPRINTING SVCS-SPORTS VOLUNTEER	\$32.00
Remit to: SACRAMENTO, CA					<u>FYTD:</u> \$33,734.00
STATE OF CALIFORNIA DEPT. OF JUSTICE	217109	05/06/2013	953046 (PCS)	FINGERPRINTING SVCS-CONTRACT CLASS INSTRUCTORS	\$448.00
			953046 (BL)	FINGERPRINTING SVCS-BUS. LICENSE RELATED	
			953046 (HR)	FINGERPRINTING SVCS-HR DEPT/EMPLOYMENT RELATED	
Remit to: SACRAMENTO, CA					<u>FYTD:</u> \$33,734.00
STATE OF CALIFORNIA DEPT. OF JUSTICE	217110	05/06/2013	958205 (HR)	FINGERPRINTING SVCS-HR DEPT/EMPLOYMENT RELATED	\$352.00
			958205 (BL)	FINGERPRINTING SVCS-BUS. LICENSE RELATED	
Remit to: SACRAMENTO, CA					<u>FYTD:</u> \$33,734.00
STATE OF CALIFORNIA DEPT. OF JUSTICE	217295	05/20/2013	958205 (SRTS)	FINGERPRINTING SVCS-SRTS PROGRAM	\$96.00
			953046	FINGERPRINTING SVCS-HR DEPT/EMPLOYMENT RELATED	
Remit to: SACRAMENTO, CA					<u>FYTD:</u> \$33,734.00
STATE OF CALIFORNIA DEPT. OF JUSTICE	217296	05/20/2013	963289 (BL)	FINGERPRINTING SVCS-BUS. LICENSE RELATED	\$448.00
			963289 (HR)	FINGERPRINTING SVCS-HR DEPT/EMPLOYMENT RELATED	
			963289 (SRTS)	FINGERPRINTING SVCS-SRTS PROGRAM	
Remit to: SACRAMENTO, CA					<u>FYTD:</u> \$33,734.00



**City of Moreno Valley
Payment Register
For Period 5/1/2013 through 5/31/2013**

CHECKS UNDER \$25,000

<u>Vendor Name</u>	<u>Check/EFT Number</u>	<u>Payment Date</u>	<u>Inv Number</u>	<u>Invoice Description</u>	<u>Payment Amount</u>
STATE OF CALIFORNIA DEPT. OF JUSTICE	217393	05/28/2013	968246	FINGERPRINTING SVCS-PD	\$2,706.00
			972156	BLOOD ALCOHOL ANALYSIS FOR PD	
Remit to: SACRAMENTO, CA				<u>FYTD:</u>	\$33,734.00
STATE OF CALIFORNIA DEPT. OF JUSTICE	217394	05/28/2013	937971 (SRTS1)	FINGERPRINTING SVCS-SRTS PROGRAM	\$64.00
			937971 (HR1)	FINGERPRINTING SVCS-HR DEPT/EMPLOYMENT RELATED	
Remit to: SACRAMENTO, CA				<u>FYTD:</u>	\$33,734.00
STEVE CODY	217222	05/13/2013	R13-059487	AS REFUND-SPAY/NEUTER & RABIES DEPOSITS	\$95.00
Remit to: WILLIAMS, AZ				<u>FYTD:</u>	\$95.00
STEVE SALAIZ	217420	05/28/2013	MAY-2013	INSTRUCTOR SVCS-TAE KWON DO CLASS	\$39.00
Remit to: MIRA LOMA, CA				<u>FYTD:</u>	\$234.00
STEVEN M DENYES	217411	05/28/2013	303	TOWNGATE PARK CONCERT-HULLABALOO BAND-6/7/13	\$900.00
Remit to: DEL MAR, CA				<u>FYTD:</u>	\$900.00
STEWART, CLIFFORD	9281	05/06/2013	130501	RETIREE MEDICAL MAY '13	\$210.74
Remit to: GLENDALE, AZ				<u>FYTD:</u>	\$2,410.90
STK ARCHITECTURE, INC.	9329	05/13/2013	19736	ANNEX 1 REDESIGN & RENOVATION PROJECT SERVICES	\$834.04
Remit to: TEMECULA, CA				<u>FYTD:</u>	\$219,081.92
STOPANI, PRISCILLA	217311	05/20/2013	REIMBURSEMENT	MILEAGE & PARKING REIMBURSEMENT FOR APPA SPRING CONF.- TRAINING	\$172.10



City of Moreno Valley
Payment Register
 For Period 5/1/2013 through 5/31/2013

CHECKS UNDER \$25,000

<u>Vendor Name</u>	<u>Check/EFT Number</u>	<u>Payment Date</u>	<u>Inv Number</u>	<u>Invoice Description</u>	<u>Payment Amount</u>
Remit to: CORONA, CA				<u>FYTD:</u>	\$172.10
STRADLING, YOCCA, CARLSON & RAUTH	9449	05/28/2013	279768-0031	LEGAL SERVICES	\$8,192.40
			279622-0000	LEGAL SERVICES	
			279614-0036	LEGAL SERVICES	
Remit to: NEWPORT BEACH, CA				<u>FYTD:</u>	\$103,319.43
STRICKLER ASSOCIATION, THE	9330	05/13/2013	4600	SURPLUS PROPERTY CONSULTING SERVICES	\$1,575.00
Remit to: SAN BERNARDINO, CA				<u>FYTD:</u>	\$17,054.98
STRICKLER ASSOCIATION, THE	9450	05/28/2013	4700	CONSULTANT SVCS-HABITAT FOR HUMANITY PROJECT	\$1,413.75
Remit to: SAN BERNARDINO, CA				<u>FYTD:</u>	\$17,054.98
STROM, BONNIE	9283	05/06/2013	130501	VSP MAY '13, PD MAY '13	\$30.33
Remit to: COLTON, CA				<u>FYTD:</u>	\$30.33
SUZANNE PARRY	217440	05/28/2013	R13-061214	AS REFUND- RABIES DEPOSIT	\$20.00
Remit to: MORENO VALLEY, CA				<u>FYTD:</u>	\$20.00
SYETA MONROE	217164	05/06/2013	1029093	REFUND PICNIC SHELTER	\$64.00
Remit to: MORENO VALLEY, CA				<u>FYTD:</u>	\$64.00
SYSCO RIVERSIDE, INC	217246	05/13/2013	BL#26101-YR2013	REFUND OF OVERPAYMENT FOR B/L #26101	\$98.31
Remit to: RIVERSIDE, CA				<u>FYTD:</u>	\$98.31
TAMI ALTER	217150	05/06/2013	R13-060848	AS REFUND-REF 2 ADOPTIONS	\$143.00



City of Moreno Valley
Payment Register
 For Period 5/1/2013 through 5/31/2013

CHECKS UNDER \$25,000

<u>Vendor Name</u>	<u>Check/EFT Number</u>	<u>Payment Date</u>	<u>Inv Number</u>	<u>Invoice Description</u>	<u>Payment Amount</u>
Remit to: SAN JACINTO, CA					FYTD: \$143.00
TARAH MURPHY	217437	05/28/2013	R13-058032	AS REFUND-RABIES DEPOSIT	\$20.00
Remit to: LAKE ELSINORE, CA					FYTD: \$20.00
TARAL PATEL	217174	05/06/2013	1030649/1030650	REFUND-READING RASCALS CLASS CANCELLED	\$104.87
Remit to: MORENO VALLEY, CA					FYTD: \$104.87
TDI SIGNS	217329	05/20/2013	BL#15502-YR2013	REFUND OF OVERPAYMENT FOR BL#15502	\$95.61
Remit to: LONG BEACH, CA					FYTD: \$95.61
THE PENWORTHY COMPANY	9219	05/06/2013	259255	CHILDREN'S SRP BOOKS FOR LIBRARY	\$830.38
Remit to: MILWAUKEE, WI					FYTD: \$1,781.53
THE SALVATION ARMY	217169	05/06/2013	1029096	REFURN FOR SPECIAL EVENT	\$75.00
Remit to: MORENO VALLEY, CA					FYTD: \$75.00
THERMAL COMBUSTION INNOVATORS	217199	05/13/2013	106609	BIOHAZARD MEDICAL WASTE DISPOSAL SVCS FOR ANIMAL SHELTER	\$72.84
Remit to: COLTON, CA					FYTD: \$945.26
THERMAL-COOL INC.	217200	05/13/2013	31701	HARD START KIT FOR ACAT MV EQUESTRIAN CENTER	\$121.42
Remit to: RIVERSIDE, CA			WO-2066	SERVICE FOR AC AT MV EQUESTRIAN CENTER	FYTD: \$1,967.19
THOMAS MADRIL	217346	05/20/2013	MVP52530	REFUND-CITATION OVERPAYMENT	\$13.50
Remit to: RIVERSIDE, CA					FYTD: \$13.50



**City of Moreno Valley
Payment Register
For Period 5/1/2013 through 5/31/2013**

CHECKS UNDER \$25,000

<u>Vendor Name</u>	<u>Check/EFT Number</u>	<u>Payment Date</u>	<u>Inv Number</u>	<u>Invoice Description</u>	<u>Payment Amount</u>
TIJUANA'S TACOS	217247	05/13/2013	BL#24180-YR2013	REFUND OF OVERPAYMENT FOR B/L #24180	\$98.12
Remit to: MORENO VALLEY, CA					
TIOS TACO NO. 3	217248	05/13/2013	BL#066641-YR2013	REFUND OF OVERPAYMENT FOR B/L #066641	\$66.95
Remit to: MORENO VALLEY, CA					
TRANE U.S. INC.	217111	05/06/2013	31904786	CITY HALL-CONTROLS SYSTEM SERVICE AGREEMENT 1946TIS-1 YR.	\$4,597.80
Remit to: CITY OF INDUSTRY, CA					
TRICHE, TARA	217312	05/20/2013	MAY-2013	INSTRUCTOR SVCS-DANCE CLASSES	\$2,708.40
Remit to: MORENO VALLEY, CA					
TRIPLE T PLUMBING	217447	05/28/2013	BL#19626-YR2013	REFUND OF OVERPAYMENT FOR BL#19626	\$96.90
Remit to: MORENO VALLEY, CA					
TROPICAL PLAZA NURSERY, INC.	9332	05/13/2013	M51807	IRRIGATION REPAIRS-ZONE E-2	\$173.04
Remit to: VILLA PARK, CA					
TRUGREEN LANDCARE	9333	05/13/2013	7512718	REMOVE EXISTING CEMENT PAD & INSTALL NEW ONE FOR BACKFLOW CASE	\$22,433.06
			7503373	LANDSCAPE MAINT.-ZONE DSG-1	
			7503374	LANDSCAPE MAINT.-ZONE E-16	
			7503372	LANDSCAPE MAINT.-ZONE M	
			7503377	LANDSCAPE MAINT.-ZONE S	
			7503376	LANDSCAPE MAINT.-ZONE E-4 & E-4A	

Item No. A.6



**City of Moreno Valley
Payment Register
For Period 5/1/2013 through 5/31/2013**

CHECKS UNDER \$25,000

<u>Vendor Name</u>	<u>Check/EFT Number</u>	<u>Payment Date</u>	<u>Inv Number</u>	<u>Invoice Description</u>	<u>Payment Amount</u>
TRUGREEN LANDCARE	9333	05/13/2013	7512652	REPLACEMENT OF 1 1/2" RB PLASTIC VALVE, COUPLING, ETC.-TR.#19541	\$22,433.06
			7510335	REPLACEMENT OF 1 1/2" RAIN BIRD PLASTIC VALVE-TR. #85	
			7510325	REPLACEMENT OF 1" RAIN BIRD PLASTIC VALVE-TR. #35	
Remit to: RIVERSIDE, CA					<u>FYTD:</u> \$283,009.79
TRUGREEN LANDCARE	9451	05/28/2013	7464882	IRRIGATION SERVICES FOR JAN. 2013-ZONE E-4	\$3,549.52
			7513166	IRRIGATION SERVICES FOR APR. 2013-ZONE E-4	
			7498101	INSTALL 6 YDS OF MULCH ON CTR ISLAND ALONG IRIS AVE BY HOSPITAL	
			7482436	IRRIGATION SERVICES FOR FEB. 2013-ZONE E-4	
			7497820	IRRIGATION SERVICES FOR MAR. 2013-ZONE E-4	
Remit to: RIVERSIDE, CA					<u>FYTD:</u> \$283,009.79
TRUST COMPLETE AUTO REPAIR AND TOWING	217330	05/20/2013	BL#22791-YR2013	REFUND OF OVERPAYMENT FOR BL#22791	\$71.18
Remit to: HEMET, CA					<u>FYTD:</u> \$71.18
TW TELECOM	217395	05/28/2013	05504952	TELECOM SVCS-LOCAL/LONG DISTANCE CALLS	\$3,137.75
			05504952a	INTERNET & DATA SERVICES	
Remit to: DENVER, CO					<u>FYTD:</u> \$35,889.39
U.S. ALL FIRE PROTECTION SYSTEMS CO.	217331	05/20/2013	FP13-0037 CORR.	REFUND OF FIRE INSPECTION & PERMIT FEES-ALBERTOS MEX. FOOD HOOD	\$238.00
Remit to: SOUTH EL MONTE, CA					<u>FYTD:</u> \$238.00
U.S. HEALTHWORKS MEDICAL GROUP	217298	05/20/2013	2264702-CA	EMPLOYMENT DOT PHYSICAL EXAMS	\$130.00



**City of Moreno Valley
Payment Register
For Period 5/1/2013 through 5/31/2013**

CHECKS UNDER \$25,000

<u>Vendor Name</u>	<u>Check/EFT Number</u>	<u>Payment Date</u>	<u>Inv Number</u>	<u>Invoice Description</u>	<u>Payment Amount</u>
Remit to: LOS ANGELES, CA				<u>FYTD:</u>	\$3,614.26
UNDERGROUND SERVICE ALERT	9392	05/20/2013	420130437 b	DIGALERT TICKETS SUBSCRIPTION SERVICE	\$381.00
			420130437 a	DIGALERT TICKETS SUBSCRIPTION SERVICE	
			420130437 c	DIGALERT TICKETS SUBSCRIPTION SERVICE	
			420130437 d	DIGALERT TICKETS SUBSCRIPTION SERVICE	
Remit to: CORONA, CA				<u>FYTD:</u>	\$4,471.50
UNITED ROTARY BRUSH CORP	9220	05/06/2013	275032	STREET SWEEPER BROOM KITS/RECONDITIONING & REPAIR PARTS	\$3,108.04
			275124	STREET SWEEPER BROOM KITS/RECONDITIONING	
			275173	STREET SWEEPER BROOM KITS/RECONDITIONING	
Remit to: ESCONDIDO, CA				<u>FYTD:</u>	\$32,016.16
UNITED ROTARY BRUSH CORP	9393	05/20/2013	275259	STREET SWEEPER BROOM KITS/RECONDITIONING & REPAIR PARTS	\$1,144.63
Remit to: ESCONDIDO, CA				<u>FYTD:</u>	\$32,016.16
UNITED SITE SERVICES OF CA, INC.	9221	05/06/2013	114-1220619	FENCE RENTAL AT ANIMAL SHELTER	\$106.65
Remit to: PHOENIX, AZ				<u>FYTD:</u>	\$1,277.80
UNITED SITE SERVICES OF CA, INC.	9335	05/13/2013	114-661202	FENCE RENTAL AT ANIMAL SHELTER	\$106.40
Remit to: EL MONTE, CA				<u>FYTD:</u>	\$1,277.80
UNITED WAY OF INLAND VALLEYS	217112	05/06/2013	2013-00000056	8720 - UNITED WAY	\$261.00



City of Moreno Valley
Payment Register
 For Period 5/1/2013 through 5/31/2013

CHECKS UNDER \$25,000

<u>Vendor Name</u>	<u>Check/EFT Number</u>	<u>Payment Date</u>	<u>Inv Number</u>	<u>Invoice Description</u>	<u>Payment Amount</u>
Remit to: RIVERSIDE, CA					<u>FYTD:</u> \$8,665.00
UNITED WAY OF INLAND VALLEYS	217299	05/20/2013	2013-00000086	8720 - UNITED WAY	\$261.00
Remit to: RIVERSIDE, CA					<u>FYTD:</u> \$8,665.00
UNIVAR USA, INC	217300	05/20/2013	RV568263	AG CHEMICALS FOR CFD #1 PARKS	\$873.18
Remit to: LOS ANGELES, CA					<u>FYTD:</u> \$12,038.89
UNIVAR USA, INC	217396	05/28/2013	LA885939	BIRD NETTING MATERIAL FOR CITY YARD CARPORT AREA WO#13-0277	\$3,949.65
Remit to: LOS ANGELES, CA					<u>FYTD:</u> \$12,038.89
UNIVERSAL SOCCER	217251	05/13/2013	BL#21232-YR2013	REFUND OF OVERPAYMENT FOR B/L #21232	\$75.00
Remit to: MORENO VALLEY, CA					<u>FYTD:</u> \$75.00
URBAN CROSSROADS, INC.	217202	05/13/2013	23885	CONSULTING SERVICES - MV ON CALL TRANSPORTATION FUNDING SUPPORT	\$7,632.50
			23936	CONSULTING SERVICES - CACTUS/NASON	
			23803	CONSULTING SERVICES - MV ON CALL TRANSPORTATION FUNDING SUPPORT	
Remit to: IRVINE, CA					<u>FYTD:</u> \$14,557.50
USA MOBILITY/ARCH WIRELESS	9336	05/13/2013	W6218870E	PAGER SERVICE	\$34.68
Remit to: SPRINGFIELD, VA					<u>FYTD:</u> \$400.85
VACATE PEST ELIMINATION COMPANY	9337	05/13/2013	40968	PEST CONTROL SERVICE-GOLF COURSE PRO SHOP	\$1,440.00
			41237	PEST CONTROL SERVICE-FIRE ST. #65	



**City of Moreno Valley
Payment Register
For Period 5/1/2013 through 5/31/2013**

CHECKS UNDER \$25,000

<u>Vendor Name</u>	<u>Check/EFT Number</u>	<u>Payment Date</u>	<u>Inv Number</u>	<u>Invoice Description</u>	<u>Payment Amount</u>
VACATE PEST ELIMINATION COMPANY	9337	05/13/2013	40970	PEST CONTROL SERVICE-CITY HALL	\$1,440.00
			40822	PEST CONTROL SERVICE-FIRE ST. #91	
			40821	PEST CONTROL SERVICE-FIRE ST. #2	
			40820	PEST CONTROL SERVICE-SENIOR CENTER	
			40819	PEST CONTROL SERVICE-FIRE ST. #58	
			40818	PEST CONTROL SERVICE-LIBRARY	
			40776	RODENT CONTROL-AQUEDUCT	
			40978	PEST CONTROL SERVICE-MARCH FIELD BLDG 823	
			40817	PEST CONTROL SERVICE-FIRE ST. #6	
			40815	PEST CONTROL SERVICE-UTILITY FIELD OFFICE	
			41097	RODENT CONTROL-ELECTRIC UTILITY SUBSTATION	
			41096	RODENT CONTROL-AQUEDUCT	
			40777	RODENT CONTROL-ELECTRIC UTILITY SUBSTATION	
			40814	PEST CONTROL SERVICE-FIRE ST. #99	
			41120	PEST CONTROL SERVICE-TRANSP. TRAILER	
			40971	PEST CONTROL SERVICE-CONFERENCE & REC CTR.	
			40973	PEST CONTROL SERVICE-PUBLIC SAFETY BLDG	
			40976	PEST CONTROL SERVICE-ANNEX BLDG 1	
			40974	PEST CONTROL SERVICE-EOC	
			40977	PEST CONTROL SERVICE-ANIMAL SHELTER	
			40979	PEST CONTROL SERVICE-MARCH FIELD PARK COMM. CTR.	
			41118	PEST CONTROL SERVICE-CITY YARD	
			40813	PEST CONTROL SERVICE-TOWNGATE COMM. CTR.	
			40812	PEST CONTROL SERVICE-FIRE ST. #48	



**City of Moreno Valley
Payment Register
For Period 5/1/2013 through 5/31/2013**

CHECKS UNDER \$25,000

<u>Vendor Name</u>	<u>Check/EFT Number</u>	<u>Payment Date</u>	<u>Inv Number</u>	<u>Invoice Description</u>	<u>Payment Amount</u>
Remit to: MORENO VALLEY, CA				<u>FYTD:</u>	\$17,225.00
VACATE PEST ELIMINATION COMPANY	9452	05/28/2013	41513	BIRD NETTING INSTALLATION-CITY YARD CARPORT AREA WO#13-0277	\$3,150.00
Remit to: MORENO VALLEY, CA				<u>FYTD:</u>	\$17,225.00
VALLEY PARTY EQUIPMENT RENTALS	217332	05/20/2013	BL#06930-YR2013	REFUND OF OVERPAYMENT FOR BL#06930	\$202.04
Remit to: MORENO VALLEY, CA				<u>FYTD:</u>	\$202.04
VALOR GROUP PERSONNEL, LLC	217453	05/28/2013	229	EMPLOYMENT PLACEMENT-D. PINSONNEAU, SENIOR ELECTR. ENGINEER-MVU	\$17,664.20
Remit to: LAKE WORTH, FL				<u>FYTD:</u>	\$17,664.20
VAS ASSOCIATES, INC.	9338	05/13/2013	178	CONSULTING PROJECT MANAGEMENT	\$21,120.00
Remit to: CORONA, CA				<u>FYTD:</u>	\$230,880.00
VASQUEZ, CAROL	217136	05/06/2013	130501	APR '13 PD MAY '13	\$318.73
Remit to: RIALTO, CA				<u>FYTD:</u>	\$1,274.92
VERIZON	217203	05/13/2013	EQN6913105-13118	BACKBONE COMMUNICATION CHARGES	\$1,744.75
Remit to: TRENTON, NJ				<u>FYTD:</u>	\$19,357.27
VERIZON CALIFORNIA	217113	05/06/2013	310 175-9704/'13	ANNUAL PHONE DIRECTORY AD	\$58.04
Remit to: DALLAS, TX				<u>FYTD:</u>	\$8,366.48
VERIZON CALIFORNIA	217301	05/20/2013	877 811-8700/'13	ANNUAL PHONE DIRECTORY LISTING	\$55.10
Remit to: DALLAS, TX				<u>FYTD:</u>	\$8,366.48



**City of Moreno Valley
Payment Register
For Period 5/1/2013 through 5/31/2013**

CHECKS UNDER \$25,000

<u>Vendor Name</u>	<u>Check/EFT Number</u>	<u>Payment Date</u>	<u>Inv Number</u>	<u>Invoice Description</u>	<u>Payment Amount</u>
VERIZON CALIFORNIA	217397	05/28/2013	951 UH2-7052/MAY	PHONE CHARGES-ERC	\$624.03
Remit to: DALLAS, TX					
VERIZON CALIFORNIA	217398	05/28/2013	1258220327MAY-13	FIOS SERVICES FOR FIRE STATION 99	\$101.56
Remit to: DALLAS, TX					
VERIZON WIRELESS	217114	05/06/2013	9703050634	CELLULAR SERVICE FOR PD TICKET WRITERS	\$230.18
Remit to: DALLAS, TX					
VICTOR HERNANDEZ	217344	05/20/2013	MV3130226005	REFUND-DISMISSED CITATION	\$57.50
Remit to: MORENO VALLEY, CA					
VICTOR MEDICAL CO	217204	05/13/2013	3249060	ANIMAL MEDICAL SUPPLIES/VACCINES	\$3,383.53
Remit to: LAKE FOREST, CA					
VIEVU	9453	05/28/2013	5531	REPAIR OF WEARABLE CAMERA FOR PD SET	\$193.00
Remit to: SEATTLE, WA					
VIGIL, ERNEST	9284	05/06/2013	130501	RETIREE MEDICAL MAY '13	\$318.73
Remit to: MORENO VALLEY, CA					
VINCENT, CLARENCE	217137	05/06/2013	130501	APR '13, PD MAY '13	\$318.73
Remit to: MORENO VALLEY, CA					
VISION SERVICE PLAN	9222	05/06/2013	130501	EMPLOYEE VISION INSURANCE	\$3,937.30



**City of Moreno Valley
Payment Register
For Period 5/1/2013 through 5/31/2013**

CHECKS UNDER \$25,000

<u>Vendor Name</u>	<u>Check/EFT Number</u>	<u>Payment Date</u>	<u>Inv Number</u>	<u>Invoice Description</u>	<u>Payment Amount</u>
Remit to: SAN FRANCISCO, CA					<u>FYTD:</u> \$43,136.42
VISTA APARTMENTS	217252	05/13/2013	BL#07051-YR2013	REFUND OF OVERPAYMENT FOR B/L #07051	\$64.02
Remit to: ORANGE, CA					<u>FYTD:</u> \$64.02
VISTA PAINT CORPORATION	217399	05/28/2013	2013-647044-00	TRAFFIC PAINT	\$6,445.33
Remit to: FULLERTON, CA					<u>FYTD:</u> \$43,985.01
VOYAGER FLEET SYSTEM, INC.	9339	05/13/2013	869211615313	CNG FUEL PURCHASES	\$2,133.81
Remit to: HOUSTON, TX					<u>FYTD:</u> \$20,299.91
VULCAN MATERIALS CO, INC.	217115	05/06/2013	329890	ASPHALTIC MATERIALS	\$1,921.66
			322971	ASPHALTIC MATERIALS	
			328809	ASPHALTIC MATERIALS	
			332906	ASPHALTIC MATERIALS	
			332907	ASPHALTIC MATERIALS	
			335192	ASPHALTIC MATERIALS	
			319804	ASPHALTIC MATERIALS - SURFACE RECYCLING PROJECTS	
Remit to: LOS ANGELES, CA					<u>FYTD:</u> \$21,190.04
WAGGONER JR., GLENN C.	9285	05/06/2013	130501	MAR '13, PD MAY '13	\$637.46
			130401	RETIREE MED OMITTED IN ERROR MAR '13	
Remit to: MORENO VALLEY, CA					<u>FYTD:</u> \$2,934.40
WAGNER, GARY D.	9286	05/06/2013	130501	RETIREE MEDICAL MAY '13	\$318.73
Remit to: MORENO VALLEY, CA					<u>FYTD:</u> \$3,187.30



**City of Moreno Valley
Payment Register
For Period 5/1/2013 through 5/31/2013**

CHECKS UNDER \$25,000

<u>Vendor Name</u>	<u>Check/EFT Number</u>	<u>Payment Date</u>	<u>Inv Number</u>	<u>Invoice Description</u>	<u>Payment Amount</u>
WAGNER, MARIANNE K	9287	05/06/2013	130501	RETREE MEDICAL MAY '13	\$318.73
Remit to: MORENO VALLEY, CA					
WAGONER, ROBERT	9288	05/06/2013	130501	APR '13, PD MAY '13	\$362.80
Remit to: ZEPHYRHILLS, FL					
WALLACE CONCRETE, INC	217253	05/13/2013	BL#24257-YR2013	REFUND OF OVERPAYMENT FOR B/L #24257	\$81.84
Remit to: YUCAIPA, CA					
WATER SPECIALIST CONSULTANTS	217401	05/28/2013	REG.-7/30/13 TRN	REGISTR. FEES FOR 4 TO ATTEND RECYCLED WATER SITE SUPV. TRAINING	\$180.00
Remit to: LA MESA, CA					
WEBFORTIS, LLC	217402	05/28/2013	7849	CONSULTING SERVICES FOR MICROSOFT CRIM 2011-FIX CODE ERROR	\$82.50
Remit to: WALNUT CREEK, CA					
WELLS FARGO BANK	217403	05/28/2013	950784	FEE INVOICE-ANNUAL ADMIN. CHARGES 4/26/13-4/25/14	\$2,000.00
Remit to: SAN FRANCISCO, CA					
WEST COAST ARBORISTS, INC.	9340	05/13/2013	87181-A	TREE TRIMMING & REMOVAL SERVICES-PARKS & CONTRACT AREAS	\$11,570.00
Remit to: ANAHEIM, CA					
WEST COAST ARBORISTS, INC.	9454	05/28/2013	87680	TREE TRIMMING & REMOVAL SERVICES-PARKS & CONTRACT AREAS	\$13,960.00
Remit to: ANAHEIM, CA					
				FYTD:	\$117,390.00
				FYTD:	\$117,390.00



**City of Moreno Valley
Payment Register
For Period 5/1/2013 through 5/31/2013**

CHECKS UNDER \$25,000

<u>Vendor Name</u>	<u>Check/EFT Number</u>	<u>Payment Date</u>	<u>Inv Number</u>	<u>Invoice Description</u>	<u>Payment Amount</u>
WEST COAST ARBORISTS, INC.	217302	05/20/2013	87283	TREE TRIMMING & REMOVAL SERVICES-PARKS & CONTRACT AREAS	\$12,040.00
Remit to: ANAHEIM, CA FYTD: \$117,390.00					
WEST PAYMENT CENTER	217404	05/28/2013	827166722	INFORMATION DATABASE SERVICE FOR PD INVESTIGATIONS	\$710.96
Remit to: CAROL STREAM, IL FYTD: \$14,030.52					
WESTERN MUNICIPAL WATER DISTRICT	217405	05/28/2013	23866-018292/APR	WATER CHARGES-SKATE PARK	\$3,626.27
			23821-018258/APR	WATER CHARGES-MFPCC BLDG 938	
			23821-018257/APR	WATER CHARGES-MFPCC LANDSCAPE	
			24753-018620/APR	WATER CHARGES-MARB BALLFIELDS	
Remit to: ARTESIA, CA FYTD: \$25,877.56					
WIBERG, CHRISTOPHER	217138	05/06/2013	130501	RETIREE MEDICAL MAY '13	\$318.73
Remit to: ANAHEIM, CA FYTD: \$3,187.30					
WIELIN, RONALD A.	9289	05/06/2013	130501	RETIREE MEDICAL MAY '13	\$318.73
Remit to: BANNING, CA FYTD: \$3,187.30					
WILLDAN ENGINEERING	217259	05/13/2013	00314882	ENGINEERING SERVICES - PAVEMENT MANAGEMENT PROGRAM	\$12,903.50
			00314966	CONSTRUCTION CONTRACT - PAVEMENT MANAGEMENT PROGRAM	
Remit to: ANAHEIM, CA FYTD: \$229,285.03					
WILLDAN FINANCIAL SERVICES	9223	05/06/2013	010-20563 a	ANNUAL CONTINUING DISCLOSURE SERVICES-2005/2007 LRB	\$1,750.00
			010-20563	ANNUAL CONTINUING DISCLOSURE SERVICES-2005 LRB	



**City of Moreno Valley
Payment Register
For Period 5/1/2013 through 5/31/2013**

CHECKS UNDER \$25,000

<u>Vendor Name</u>	<u>Check/EFT Number</u>	<u>Payment Date</u>	<u>Inv Number</u>	<u>Invoice Description</u>	<u>Payment Amount</u>
Remit to: TEMECULA, CA					<u>FYTD:</u> \$37,008.00
WILLIAMS, JANE L.	9290	05/06/2013	130501	OCT '12 DENTAL/ FEB-MAR '13, PD MAY '13	\$256.12
Remit to: GRAND FORKS, ND					<u>FYTD:</u> \$1,611.96
WILLIS, ROBERT H	217116	05/06/2013	042513 - 042813	SPORTS OFFICIATING SERVICES-SOFTBALL	\$400.00
			040413 - 042113	SPORTS OFFICIATING SERVICES-SOFTBALL	
			030313	SPORTS OFFICIATING SERVICES-SOFTBALL	
Remit to: PERRIS, CA					<u>FYTD:</u> \$2,100.00
WILLIS, ROBERT H	217406	05/28/2013	051913	SPORTS OFFICIATING SERVICES-SOFTBALL	\$160.00
			050913	SPORTS OFFICIATING SERVICES-SOFTBALL	
			050513	SPORTS OFFICIATING SERVICES-SOFTBALL	
Remit to: PERRIS, CA					<u>FYTD:</u> \$2,100.00
WILSON-BEILKE, DENESE	217139	05/06/2013	130501	RETIREE MEDICAL MAY '13	\$318.73
Remit to: GLENDORA, CA					<u>FYTD:</u> \$4,462.22
WJRM'S JANITORIAL SERVICES, INC.	9224	05/06/2013	22156	CLEANING OF 3 CHAIRS AT EMP. RESOURCE CENTER	\$75.00
Remit to: CORONA, CA					<u>FYTD:</u> \$279,788.95
WJRM'S JANITORIAL SERVICES, INC.	9395	05/20/2013	22203	JANITORIAL SVCS-CITY YARD & TRANSP. TRAILER	\$21,970.34
			22213	JANITORIAL SVCS-SUNNYMEAD MIDDLE SCHOOL/ASES	
			22202	JANITORIAL SVCS-CITY HALL	
			22205	JANITORIAL SVCS-EOC	

Item No. A.6



**City of Moreno Valley
Payment Register
For Period 5/1/2013 through 5/31/2013**

CHECKS UNDER \$25,000

<u>Vendor Name</u>	<u>Check/EFT Number</u>	<u>Payment Date</u>	<u>Inv Number</u>	<u>Invoice Description</u>	<u>Payment Amount</u>
WURM'S JANITORIAL SERVICES, INC.	9395	05/20/2013	22207	JANITORIAL SVCS-LIBRARY	\$21,970.34
			22208	JANITORIAL SVCS-MARCH FIELD PARK COMM. CTR.	
			22209	JANITORIAL SVCS-PUBLIC SAFETY BLDG.	
			22212	JANITORIAL SVCS-SENIOR CENTER	
			22214	JANITORIAL SVCS-TOWNGATE COMM. CTR.	
			22216	JANITORIAL SVCS-ANNEX 1	
			22211	JANITORIAL SVCS-RAINBOW RIDGE FOR "A CHILD'S PLACE"	
			22204	JANITORIAL SVCS-CONFERENCE & REC. CTR	
			22215	JANITORIAL SVCS-SUNNYMEAD ELEMENTARY FOR "A CHILD'S PLACE"	
Remit to: CORONA, CA					FYTD: \$279,788.95
WURM'S JANITORIAL SERVICES, INC.	9455	05/28/2013	22206	JANITORIAL SVCS-EMP. RESOURCE CENTER	\$2,710.63
			22210	JANITORIAL SVCS-GANG TASK FORCE OFFICE	
			22236	SPECIAL CLEANINGS FOR EVENT RENTALS AT CRC	
			22235	SPECIAL CLEANINGS FOR EVENT RENTALS AT TOWNGATE COMM. CTR.	
			22234	SPECIAL CLEANINGS FOR EVENT RENTALS AT SENIOR CENTER	
Remit to: CORONA, CA					FYTD: \$279,788.95

XEROX CAPITAL SERVICES, LLC	217205	05/13/2013	067856952	COPIER LEASE FOR PARKS DEPT.	\$2,616.40
			067856953	COPIER LEASE FOR GRAPHICS DEPT.	
			067560043	COPIER LEASE & BILLABLE PRINTS FOR GRAPHICS DEPT.	
			067856951	COPIER RENTAL/MAINT. FOR PD	



City of Moreno Valley
Payment Register
 For Period 5/1/2013 through 5/31/2013

CHECKS UNDER \$25,000

<u>Vendor Name</u>	<u>Check/EFT Number</u>	<u>Payment Date</u>	<u>Inv Number</u>	<u>Invoice Description</u>	<u>Payment Amount</u>
XEROX CAPITAL SERVICES, LLC	217205	05/13/2013	067560042	COPIER RENTAL & QTRLY BILLABLE PRINTS FOR PD	\$2,616.40
Remit to: PASADENA, CA					<u>FYTD:</u> \$40,158.94
YAMASHITA, JULIA J.	9291	05/06/2013	130501	FEVB-MAR '13 PD MAY '13	\$293.80
Remit to: LAGUNA WOODS, CA					<u>FYTD:</u> \$1,280.10
YASER R. TELLO	217168	05/06/2013	CK#2331	REISSUE UNCLAIMED CK#2331 DTD 6/30/09	\$129.86
Remit to: MORENO VALLEY, CA					<u>FYTD:</u> \$129.86
ZUMAR INDUSTRIES, INC.	9396	05/20/2013	0144712 0144930	STENCIL SUPPLIES-EPOXY & DISPENSER STENCIL SUPPLIES-5 GAL. Z5 STENCIL COAT	\$740.65
Remit to: SANTA FE SPRINGS, CA					<u>FYTD:</u> \$1,249.99
TOTAL CHECKS UNDER \$25,000					\$1,350,719.80
GRAND TOTAL					\$12,527,069.50

This page intentionally left blank.

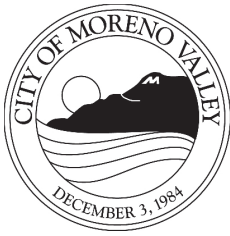

APPROVALS	
BUDGET OFFICER	<i>me</i>
CITY ATTORNEY	<i>SMB</i>
CITY MANAGER	<i>d</i>

Report to City Council

TO: Mayor and City Council

FROM: Richard Teichert, Chief Financial Officer

AGENDA DATE: August 27, 2013

TITLE: APPROVAL OF PAYMENT REGISTER FOR JUNE, 2013

RECOMMENDED ACTION

Recommendation:

1. Adopt Resolution No. 2013-67, approving the Payment Register for the month of June, 2013 in the amount of \$22,008,214.83.

DISCUSSION

To facilitate Council's review, the Payment Register lists in alphabetical order all checks in the amount of \$25,000 or greater, followed by a listing in alphabetical order of all checks less than \$25,000. The Payment Register also includes wire transfers, thus eliminating the need for a separate wire transfer register, as well as the fiscal year-to-date (FYTD) amount paid to each vendor.

FISCAL IMPACT

The disbursements itemized in the attached Payment Register are reflected in the FY 2012-13 budget. Therefore, there is no fiscal impact other than the expenditure of budgeted funds.

ATTACHMENTS

Attachment 1: Proposed Resolution

Attachment 2: Payment Register for Month of June, 2013

Prepared By:
Dena Heald
Financial Operations Division Manager

Department Head Approval:
Richard Teichert
Chief Financial Officer

Council Action	
Approved as requested:	Referred to:
Approved as amended:	For:
Denied:	Continued until:
Other:	Hearing set for:

RESOLUTION NO. 2013-67

A RESOLUTION OF THE CITY COUNCIL OF THE CITY OF MORENO VALLEY, CALIFORNIA, APPROVING THE PAYMENT REGISTER FOR THE MONTH OF JUNE, 2013

WHEREAS, the Financial & Management Services Department has prepared and provided the Payment Register for the period June 1, 2013 through June 30, 2013, for review and approval by the City Council of the City of Moreno Valley; and

WHEREAS, it is in the best interest of the City that the referenced Payment Register be approved.

NOW, THEREFORE, IT IS HEREBY RESOLVED BY THE CITY COUNCIL OF THE CITY OF MORENO VALLEY, CALIFORNIA, that the Payment Register for the period June 1, 2013 through June 30, 2013, in the total amount of \$22,008,214.83 is approved.

APPROVED AND ADOPTED this 27th day of August, 2013.

Mayor

ATTEST:

City Clerk

APPROVED AS TO FORM:

City Attorney

1
Resolution No. 2013-67
Date Adopted: August 27, 2013

RESOLUTION JURAT

STATE OF CALIFORNIA)
COUNTY OF RIVERSIDE) ss.
CITY OF MORENO VALLEY)

I, Jane Halstead, City Clerk of the City of Moreno Valley, California, do hereby certify that Resolution No. 2013-67 was duly and regularly adopted by the City Council of the City of Moreno Valley at a regular meeting thereof held on the 27th day of August, 2013 by the following vote:

AYES:

NOES:

ABSENT:

ABSTAIN:

CITY CLERK

Resolution No. 2013-67²
Date Adopted: August 27, 2013



**City of Moreno Valley
Payment Register
For Period 6/1/2013 through 6/30/2013**

CHECKS IN THE AMOUNT OF \$25,000 OR GREATER

<u>Vendor Name</u>	<u>Check/EFT Number</u>	<u>Payment Date</u>	<u>Inv Number</u>	<u>Invoice Description</u>	<u>Payment Amount</u>
ALL AMERICAN ASPHALT, INC.	217691	06/24/2013	17	CONSTRUCTION CONTRACT - SR-60/NASON IC	\$297,777.46
Remit to: CORONA, CA					
BIO-TOX LABORATORIES	217538	06/10/2013	26676	BLOOD DRAW TOXICOLOGY ANALYSIS	\$25,476.21
			26677	BLOOD DRAW TOXICOLOGY ANALYSIS	
			26815	BLOOD DRAW TOXICOLOGY ANALYSIS	
Remit to: RIVERSIDE, CA					
CANON SOLUTIONS AMERICA, INC.	9470	06/03/2013	1103031201304152	COPIER SVC-JAN THRU MAR 2013	\$26,709.90
Remit to: BURLINGTON, NJ					
COUNTY OF RIVERSIDE - RMAP	217581	06/10/2013	SH0000021494	REIMB. FOR SEXUAL ASSAULT EXAMS BILLED TO THE COUNTY BY RCRM	\$27,900.00
Remit to: MORENO VALLEY, CA					
COUNTY OF RIVERSIDE FIRE DEPT	9575	06/10/2013	231452	FIRE SVCS CONTRACT-3RD QTR F/Y12-13	\$3,581,897.85
Remit to: PERRIS, CA					
COUNTY OF RIVERSIDE SHERIFF	9658	06/24/2013	SH0000021398	CONTRACT LAW ENFORCEMENT BILLING #10 (3/7/13-4/3/13)	\$2,913,735.87
Remit to: RIVERSIDE, CA					
COUNTY OF RIVERSIDE, AUDITOR- CONTROLLER	217699	06/24/2013	FEB-13	TRANSMITTAL OF AB544-PARKING CONTROL FEES	\$27,449.07
Remit to: RIVERSIDE, CA					
EASTERN MUNICIPAL WATER DISTRICT	217460	06/03/2013	MAY-13 6/3/13	WATER CHARGES	\$47,477.87
Remit to: RIVERSIDE, CA					
				FYTD:	\$1,840,887.79
				FYTD:	\$137,348.41
				FYTD:	\$107,894.04
				FYTD:	\$654,277.25
				FYTD:	\$35,548,658.25
				FYTD:	\$192,276.95



**City of Moreno Valley
Payment Register
For Period 6/1/2013 through 6/30/2013**

CHECKS IN THE AMOUNT OF \$25,000 OR GREATER

<u>Vendor Name</u>	<u>Check/EFT Number</u>	<u>Payment Date</u>	<u>Inv Number</u>	<u>Invoice Description</u>	<u>Payment Amount</u>
Remit to: PERRIS, CA					<u>FYTD:</u> \$1,504,961.70
EASTERN MUNICIPAL WATER DISTRICT	217613	06/17/2013	MAY-13 6/17/13	WATER CHARGES	\$50,691.66
Remit to: PERRIS, CA					<u>FYTD:</u> \$1,504,961.70
EASTERN MUNICIPAL WATER DISTRICT	217702	06/24/2013	MAY-13 6/24/13	WATER CHARGES	\$39,634.44
Remit to: PERRIS, CA					<u>FYTD:</u> \$1,504,961.70
EMPLOYMENT DEVELOPMENT DEPARTMENT	9616	06/14/2013	2013-00000120	CA TAX - STATE TAX WITHHOLDING*	\$30,709.39
Remit to: WEST SACRAMENTO, CA					<u>FYTD:</u> \$1,001,685.05
EMPLOYMENT DEVELOPMENT DEPARTMENT	9704	06/28/2013	2013-00000137	CA TAX - STATE TAX WITHHOLDING	\$30,142.94
Remit to: WEST SACRAMENTO, CA					<u>FYTD:</u> \$1,001,685.05
ESRI, INC.	9662	06/24/2013	92662043	ARCGIS & ARCPAD SOFTWARE	\$42,260.01
Remit to: REDLANDS, CA					<u>FYTD:</u> \$72,747.83
FALCON ENGINEERING SERVICES, INC.	9663	06/24/2013	2012-09	CONSTRUCTION INSPECTION SERVICES - SR-60/NASON IC	\$217,408.07
Remit to: CORONA, CA					<u>FYTD:</u> \$1,407,770.41
FALCON ENGINEERING SERVICES, INC.	9691	06/27/2013	2012-11-A	CONSTRUCTION SUPPORT - SR-60/MB PH I	\$66,699.95
Remit to: CORONA, CA					<u>FYTD:</u> \$1,407,770.41



**City of Moreno Valley
Payment Register
For Period 6/1/2013 through 6/30/2013**

CHECKS IN THE AMOUNT OF \$25,000 OR GREATER

<u>Vendor Name</u>	<u>Check/EFT Number</u>	<u>Payment Date</u>	<u>Inv Number</u>	<u>Invoice Description</u>	<u>Payment Amount</u>
GIBBS, GIDEN, LOCHER, TURNER, SENET & WITTBRODT LLP	9582	06/10/2013	219137-003	PROFESSIONAL LEGAL SERVICES - CACTUS/NASON	\$31,661.14
			219816-004	LEGAL SVCS-LINEAR PARK BOND SAFEGUARD	
			219346-003	PROFESSIONAL LEGAL SERVICES - DAY ST.	
Remit to: LOS ANGELES, CA					FYTD: \$245,815.09
INTERNAL REVENUE SERVICE CENTER	9617	06/14/2013	2013-00000121	FED TAX - FEDERAL TAX WITHHOLDING*	\$123,039.18
Remit to: OGDEN, UT					FYTD: \$752,783.45
INTERNAL REVENUE SERVICE CENTER	9703	06/28/2013	2013-00000136	FED TAX - FEDERAL TAX WITHHOLDING*	\$121,151.75
Remit to: OGDEN, UT					FYTD: \$752,783.45
KIMLEY-HORN & ASSOC., INC.	217531	06/03/2013	5060619	CONSULTING SERVICES, ENGINEERING - TRANSPORTATION MGMT. CTR	\$28,779.27
			5091306	CONSULTING SERVICES, ENGINEERING - TRANSPORTATION MGMT. CTR.	
Remit to: SAN DIEGO, CA					FYTD: \$53,024.68
LCTH INVESTMENT, LP	9839	06/13/2013	W130605	ACQUISITION COSTS & ESCROW FEES-APN'S 488-080-003 & 488-080-012	\$214,642.00
Remit to: NEWPORT BEACH, CA					FYTD: \$214,642.00
LEIGHTON CONSULTING, INC.	9634	06/17/2013	11484	CONSULTING SERVICES, GEOTECHNICAL - CACTUS/NASON	\$52,816.65
			11782	CONSULTING SERVICES, GEOTECHNICAL - CACTUS/NASON	
			11178	CONSULTING SERVICES, GEOTECHNICAL - CACTUS/NASON	
Remit to: IRVINE, CA					FYTD: \$440,099.45



**City of Moreno Valley
Payment Register
For Period 6/1/2013 through 6/30/2013**

CHECKS IN THE AMOUNT OF \$25,000 OR GREATER

<u>Vendor Name</u>	<u>Check/EFT Number</u>	<u>Payment Date</u>	<u>Inv Number</u>	<u>Invoice Description</u>	<u>Payment Amount</u>
LEIGHTON CONSULTING, INC.	9692	06/27/2013	11790A 12122	CONSULTING SERVICES, GEOTECHNICAL - SR-60/NASON OC CONSULTING SERVICES, GEOTECHNICAL - SR-60/NASON OC	\$54,337.54
Remit to: IRVINE, CA					
MATCH CORPORATION	9637	06/17/2013	157303 157390 157392	ASPHALTIC MATERIALS-SURFACE RECYCLING PROJ ASPHALTIC MATERIALS-SURFACE RECYCLING PROJ ASPHALTIC MATERIALS-SURFACE RECYCLING PROJ	\$25,905.85
Remit to: HIGHLAND, CA					
MORENO VALLEY UTILITY	217624	06/17/2013	7013411-01/MAY13 JUN-13 6/17/13	ELECTRICITY-UTILITY FIELD OFFICE ELECTRICITY	\$62,219.67
Remit to: HEMET, CA					
NATIONWIDE RETIREMENT SOLUTIONS CP	9615	06/14/2013	2013-00000119	8010 - DEF COMP 457 - NATIONWIDE*	\$28,318.73
Remit to: COLUMBUS, OH					
NATIONWIDE RETIREMENT SOLUTIONS CP	9700	06/28/2013	2013-00000133	8010 - DEF COMP 457 - NATIONWIDE*	\$28,318.77
Remit to: COLUMBUS, OH					
PARSONS TRANSPORTATION GROUP, INC.	9678	06/24/2013	1306A240 1306A239	CONSTRUCTION SUPPORT - SR-60/NASON OC CONSTRUCTION SUPPORT - SR-60/MB PH I	\$45,823.60
Remit to: IRVINE, CA					
PERS HEALTH INSURANCE	9619	06/07/2013	W130601	EMPLOYEE HEALTH INSURANCE	\$205,287.00
Remit to: IRVINE, CA					
					FYTD: \$1,198,847.37



**City of Moreno Valley
Payment Register
For Period 6/1/2013 through 6/30/2013**

CHECKS IN THE AMOUNT OF \$25,000 OR GREATER

<u>Vendor Name</u>	<u>Check/EFT Number</u>	<u>Payment Date</u>	<u>Inv Number</u>	<u>Invoice Description</u>	<u>Payment Amount</u>
Remit to: SACRAMENTO, CA				<u>FYTD:</u>	\$2,410,150.56
PERS RETIREMENT	9622	06/07/2013	P130524	PERS RETIREMENT DEPOSIT - CLASSIC	\$218,529.07
Remit to: SACRAMENTO, CA				<u>FYTD:</u>	\$6,282,891.10
PERS RETIREMENT	9695	06/21/2013	P130607	PERS RETIREMENT DEPOSIT - CLASSIC	\$217,615.54
Remit to: SACRAMENTO, CA				<u>FYTD:</u>	\$6,282,891.10
PERS RETIREMENT	9857	06/30/2013	P130621	PERS RETIREMENT DEPOSIT - CLASSIC	\$215,934.90
Remit to: SACRAMENTO, CA				<u>FYTD:</u>	\$6,282,891.10
POWELL CONSTRUCTORS, INC.	217469	06/03/2013	06	CONSTRUCTION CONTRACT - SR/60-MB PH I	\$706,334.36
Remit to: FONTANA, CA				<u>FYTD:</u>	\$4,212,952.02
POWELL CONSTRUCTORS, INC.	217709	06/24/2013	07	CONSTRUCTION CONTRACT - SR-60/MB PH I	\$1,006,250.85
Remit to: FONTANA, CA				<u>FYTD:</u>	\$4,212,952.02
POWELL CONSTRUCTORS, INC.	217749	06/27/2013	08	CONSTRUCTION CONTRACT - SR-60/MB PH I	\$993,228.32
Remit to: FONTANA, CA				<u>FYTD:</u>	\$4,212,952.02
PRICE FAMILY CHARITABLE TRUST	217643	06/17/2013	4TH QTR 2012	SALES TAX REIMBURSEMENT	\$170,414.00
Remit to: LA JOLLA, CA				<u>FYTD:</u>	\$676,351.00
RASMUSSEN BROTHERS CONSTRUCTION	217712	06/24/2013	MVCH 2FL 2	CONSTRUCTION CONTRACT - CITY HALL 2ND LEVEL	\$345,505.50
Remit to: FALLBROOK, CA				<u>FYTD:</u>	\$596,836.07
RECYCLE AWAY, LLC	217713	06/24/2013	5075	METAL RECYCLING RECEPTALES	\$56,724.00



**City of Moreno Valley
Payment Register
For Period 6/1/2013 through 6/30/2013**

CHECKS IN THE AMOUNT OF \$25,000 OR GREATER

<u>Vendor Name</u>	<u>Check/EFT Number</u>	<u>Payment Date</u>	<u>Inv Number</u>	<u>Invoice Description</u>	<u>Payment Amount</u>
Remit to: BRATTLEBORO, VT				<u>FYTD:</u>	\$56,724.00
RICK ENGINEERING COMPANY	9592	06/10/2013	0031505	CONSULTING SERVICES, SURVEY ROS - CACTUS/NASON	\$26,398.75
			0031390	CONSULTING SERVICES, SURVEY - CACTUS/NASON	
Remit to: RIVERSIDE, CA				<u>FYTD:</u>	\$197,576.96
RIVERSIDE CONSTRUCTION COMPANY, INC	9680	06/24/2013	130502	CONSTRUCTION CONTRACT - SR-60/NASON OC	\$971,640.52
Remit to: RIVERSIDE, CA				<u>FYTD:</u>	\$5,514,077.08
RIVERSIDE CONSTRUCTION COMPANY, INC	9694	06/27/2013	130601	CONSTRUCTION CONTRACT - SR-60/NASON	\$1,370,358.66
Remit to: RIVERSIDE, CA				<u>FYTD:</u>	\$5,514,077.08
RIVERSIDE CONSTRUCTION COMPANY, INC	9841	06/18/2013	W130608	RETENTION RELEASE PER ESCROW AGREEMENT	\$111,958.66
Remit to: RIVERSIDE, CA				<u>FYTD:</u>	\$5,514,077.08
SEQUEL CONTRACTORS, INC.	9681	06/24/2013	442-2	CONSTRUCTION CONTRACT - ALESSANDRO BLVD IMP.	\$34,132.91
Remit to: SANTA FE SPRINGS, CA				<u>FYTD:</u>	\$273,635.98
SHELL ENERGY NORTH AMERICA (US) L.P.	9645	06/17/2013	1191679	ELECTRIC ENERGY PURCHASE FOR MV UTILITY	\$981,848.00
			1201168	ELECTRIC ENERGY PURCHASE FOR MV UTILITY	
Remit to: PHILADELPHIA, PA				<u>FYTD:</u>	\$6,185,642.40
SIERRA PACIFIC ELECTRICAL CONTRACTING	217477	06/03/2013	22769	REMOVAL & REPLACEMENT OF TRAFFIC SIGNAL WIRES @ 4 INTERSECTIONS	\$58,798.00



**City of Moreno Valley
Payment Register
For Period 6/1/2013 through 6/30/2013**

CHECKS IN THE AMOUNT OF \$25,000 OR GREATER

<u>Vendor Name</u>	<u>Check/EFT Number</u>	<u>Payment Date</u>	<u>Inv Number</u>	<u>Invoice Description</u>	<u>Payment Amount</u>
Remit to: RIVERSIDE, CA					
SINGER & COFFIN, APC	9594	06/10/2013	4017	PROFESSIONAL LEGAL SERVICES - SR-60/MB PH II	\$28,021.86
			4002	PROFESSIONAL LEGAL SERVICES - SR-60/MB	
Remit to: IRVINE, CA					
SOCO GROUP, INC	9483	06/03/2013	691328	FUEL FOR CITY VEHICLES & EQUIPMENT	\$48,800.55
			696015	RED DYED DIESEL FUEL FOR CITY HALL & EOC EMERGENCY GENERATORS	
			695482	FUEL FOR CITY VEHICLES & EQUIPMENT	
			696014	RED DYED DIESEL FUEL FOR CITY HALL & EOC EMERGENCY GENERATORS	
			696013	RED DYED DIESEL FUEL FOR CITY HALL & EOC EMERGENCY GENERATORS	
			696017	RED DYED DIESEL FUEL FOR CITY HALL & EOC EMERGENCY GENERATORS	
			695194	FUEL FOR CITY VEHICLES & EQUIPMENT	
Remit to: PERRIS, CA					
SOUTHERN CALIFORNIA EDISON 1	217479	06/03/2013	7500285490	WDAT CHARGES-GRAHAM ST. LOCATION	\$34,175.48
			7500285491	WDAT CHARGES-GLOBE ST. LOCATION	
			7500285492	WDAT CHARGES-NANDINA AVE. LOCATION	
			7500285493	WDAT CHARGES-FREDERICK AVE. LOCATION	
			7500285494	WDAT CHARGES-SUBSTATION 115KV INTERCONNECTION	
			7500285760	RELIABILITY SERVICE-DLAP_SCE_SEES_HV	
			7500285489	WDAT CHARGES-IRIS AVE. LOCATION	
FYTD:					\$373,580.48



**City of Moreno Valley
Payment Register
For Period 6/1/2013 through 6/30/2013**

CHECKS IN THE AMOUNT OF \$25,000 OR GREATER

<u>Vendor Name</u>	<u>Check/EFT Number</u>	<u>Payment Date</u>	<u>Inv Number</u>	<u>Invoice Description</u>	<u>Payment Amount</u>
Remit to: ROSEMEAD, CA					<u>FYTD:</u> \$3,146,869.57
SOUTHERN CALIFORNIA EDISON 1	217632	06/17/2013	587-9520 MAY-13	ELECTRICITY-FERC CHARGES	\$156,695.50
			707-6081 MAY-13	ELECTRICITY	
			721-3449 MAY-13	IFA CHARGES-SUBSTATION	
			MAY-13 6/17/13	ELECTRICITY	
Remit to: ROSEMEAD, CA					<u>FYTD:</u> \$3,146,869.57
SOUTHERN CALIFORNIA EDISON 1	217719	06/24/2013	MAY-13 6/24/13	ELECTRICITY	\$30,836.70
Remit to: ROSEMEAD, CA					<u>FYTD:</u> \$3,146,869.57
STANDARD INSURANCE CO	9647	06/17/2013	130601a	MISCELLANEOUS SERVICES	\$39,840.95
Remit to: PORTLAND, OR					<u>FYTD:</u> \$376,006.03
STATE TREASURER'S OFFICE	9844	06/27/2013	W130609	ROW ADDL. DEPOSIT-SR60 MORENO BEACH PH2-APN'S 488-080-014 & 017	\$28,110.00
Remit to: SACRAMENTO, CA					<u>FYTD:</u> \$3,536,200.00
STATE TREASURER'S OFFICE	9845	06/27/2013	W130610	ROW ADDL. DEPOSIT-SR60 MORENO BEACH PH2-APN'S 488-080-013	\$310,380.00
Remit to: SACRAMENTO, CA					<u>FYTD:</u> \$3,536,200.00
STATE TREASURER'S OFFICE	9846	06/27/2013	W130611	ROW ADDL. DEPOSIT-SR60 MORENO BEACH PH2-APN'S 488-080-016	\$167,855.00
Remit to: SACRAMENTO, CA					<u>FYTD:</u> \$3,536,200.00
SULLY- MILLER CONTRACTING CO., INC.	9840	06/18/2013	W130607	RETENTION RELEASE PER ESCROW AGREEMENT	\$66,457.07



**City of Moreno Valley
Payment Register
For Period 6/1/2013 through 6/30/2013**

CHECKS IN THE AMOUNT OF \$25,000 OR GREATER

<u>Vendor Name</u>	<u>Check/EFT Number</u>	<u>Payment Date</u>	<u>Inv Number</u>	<u>Invoice Description</u>	<u>Payment Amount</u>
Remit to: BREA, CA					<u>FYTD:</u> \$19,735,366.95
SULLY- MILLER CONTRACTING CO., INC.	217645	06/17/2013	13-SMC	CONSTRUCTION CONTRACT - CACTUS/NASON	\$1,008,017.18
Remit to: BREA, CA					<u>FYTD:</u> \$19,735,366.95
THINK TOGETHER, INC	9686	06/24/2013	111000-12/13-10	ASES PROGRAM MANAGEMENT SERVICES	\$444,467.51
Remit to: LOS ANGELES, CA					<u>FYTD:</u> \$4,486,703.15
TRANSTECH ENGINEERS, INC.	217569	06/10/2013	15	CONSULTING SERVICES, ENGINEERING - CACTUS/NASON	\$115,370.37
			14	CONSULTING SERVICES, ENGINEERING - CACTUS/NASON	
Remit to: WALNUT, CA					<u>FYTD:</u> \$614,464.73
TRUGREEN LANDCARE	9649	06/17/2013	7526107	LANDSCAPE MAINT.-ZONE E-16	\$25,273.57
			7526106	LANDSCAPE MAINT.-ZONE DSG-1	
			7523481	REPAIR OF BROKEN 4" IRRIG. MAIN LINE-CLOCK #3-E ALONG CACTUS AVE	
			7526109	LANDSCAPE MAINT.-ZONE E-4 & E-4A	
			7526110	LANDSCAPE MAINT.-ZONE S	
			7529516	LANDSCAPE MAINT.-ZONE M	
			7529095	IRRIGATION REPAIRS FOR MAY 2013-ZONE E-4	
			7518167	REPLACEMENT OF PLASTIC RAINBIRD VALVE-TRACT #19, #16769	
			7518174	REPLACEMENT OF PLASTIC RAINBIRD VALVE-TRACT #35, #19541	
Remit to: RIVERSIDE, CA					<u>FYTD:</u> \$308,283.36
U.S. BANK/CALCARDS	9601	06/10/2013	05-27-13	CALCARD PAYMENT FOR CYCLE END 5/27/13	\$226,752.85



**City of Moreno Valley
Payment Register
For Period 6/1/2013 through 6/30/2013**

CHECKS IN THE AMOUNT OF \$25,000 OR GREATER

<u>Vendor Name</u>	<u>Check/EFT Number</u>	<u>Payment Date</u>	<u>Inv Number</u>	<u>Invoice Description</u>	<u>Payment Amount</u>
Remit to: ST. LOUIS, MO				<u>FYTD:</u>	\$2,172,304.13
WASTE MANAGEMENT	217575	06/10/2013	RECEIPT 335019	SOLID WASTE DELINQUENCIES PASS THRU, LESS FRANCHISE FEES	\$813,377.51
Remit to: CORONA, CA				<u>FYTD:</u>	\$1,737,185.02
WELLS FARGO BANK	9620	06/10/2013	W130602	ACQUISITION COSTS & ESCOW FEES/NSP3 PROGRAM-14861 WINTERGREEN ST	\$139,787.09
Remit to: SAN FRANCISCO, CA				<u>FYTD:</u>	\$959,274.65
WELLS FARGO CORPORATE	9842	06/19/2013	W130604	DEBT SERVICE-SPECIAL TAXES	\$954,745.42
Remit to: LOS ANGELES, CA				<u>FYTD:</u>	\$8,993,898.70
WELLS FARGO CORPORATE	9843	06/19/2013	W130606	DEBT SERVICE-BOND PREPAYMENT	\$39,580.29
Remit to: LOS ANGELES, CA				<u>FYTD:</u>	\$8,993,898.70
WILLDAN ENGINEERING	9488	06/03/2013	002-13273	PLAN CHECK & INSPECTION SERVICES FOR BLDG & SAFETY DEPT.	\$30,340.23
			002-13110	PLAN CHECK & INSPECTION SERVICES FOR BLDG & SAFETY DEPT.	
			002-13181	PLAN CHECK & INSPECTION SERVICES FOR BLDG & SAFETY DEPT.	
Remit to: ANAHEIM, CA				<u>FYTD:</u>	\$259,625.26
WRCOG WESTERN RIVERSIDE CO. OF GOVT'S.	217577	06/10/2013	MAY-13 TUMF	TUMF FEES COLLECTED FOR 5/1-5/31/13	\$200,682.07
Remit to: RIVERSIDE, CA				<u>FYTD:</u>	\$1,548,207.56

TOTAL AMOUNTS OF \$25,000 OR GREATER **\$20,843,511.08**



**City of Moreno Valley
Payment Register
For Period 6/1/2013 through 6/30/2013**

CHECKS UNDER \$25,000

<u>Vendor Name</u>	<u>Check/EFT Number</u>	<u>Payment Date</u>	<u>Inv Number</u>	<u>Invoice Description</u>	<u>Payment Amount</u>
2013 CF CONFERENCE	217522	06/03/2013	REG ID: 56258270	REGISTR. FEES FOR JULY15-17 CONF.-GAGATCH/FRANSIK/CUMBERLAND	\$1,035.11
Remit to: RIVERSIDE, CA					
A.D. WILSON, INC.	217686	06/24/2013	004067	SR60 MORENO BEACH DR INTERCHANGE IMPRVT PROJ	\$7,161.26
Remit to: NORCO, CA					
ABILITY COUNTS, INC	217687	06/24/2013	ACI10017	LANDSCAPE MAINT-PARKS-VRS LOCATIONS	\$2,065.00
Remit to: CORONA, CA					
ACTION DOOR REPAIR CORP.	9567	06/10/2013	85762	EXTERIOR DOOR REPAIR-ANIMAL SHELTER	\$122.50
Remit to: ORLANDO, FL					
ACTIVE NETWORK, INC., THE	9468	06/03/2013	1006658	PROFESSIONAL SVCS-LOGOS PROJECT	\$6,745.00
Remit to: SAN DIEGO, CA					
ACTIVE NETWORK, INC., THE	9654	06/24/2013	1006797	PROFESSIONAL SVCS-SETUP OF CHECK SCANNER	\$190.00
Remit to: SAN DIEGO, CA					
ADAMS, MARK L.	9490	06/03/2013	130601	RETIREE MED JUNE '13	\$318.73
Remit to: REDLANDS, CA					
ADLERHORST INTERNATIONAL INC.	9568	06/10/2013	18326	MONTHLY K-9 TRAINING-IVAN-APR13	\$141.67
Remit to: RIVERSIDE, CA					
ADMINSURE	217533	06/10/2013	6392	WORKERS' COMP CLAIMS ADMIN.-JUN13	\$2,600.00
Remit to: RIVERSIDE, CA					



**City of Moreno Valley
Payment Register
For Period 6/1/2013 through 6/30/2013**

CHECKS UNDER \$25,000

<u>Vendor Name</u>	<u>Check/EFT Number</u>	<u>Payment Date</u>	<u>Inv Number</u>	<u>Invoice Description</u>	<u>Payment Amount</u>
Remit to: DIAMOND BAR, CA					
	217534	06/10/2013	10745	ELECTRICAL REPAIRS-CITY YARD	\$33,800.00
			10741	ELECTRICAL REPAIRS-CRC/FITNESS 19	
			10748	ELECTRICAL REPAIRS-FIRE STATION #91	
			10747	ELECTRICAL REPAIRS-CRC	
			10739	ELECTRICAL REPAIRS-CRC	
			10752	ELECTRICAL REPAIRS-TOWNGATE CTR	
			10751	ELECTRICAL REPAIRS-PSB	
			10738	ELECTRICAL REPAIRS-CRC	
			10746	ELECTRICAL REPAIRS-CITY YARD TRANSP. TRAILER	
			01485	ELECTRICAL REPAIRS-ANIMAL SHELTER	
			10750	ELECTRICAL REPAIRS-FIRE STATION #2	
			01484	ELECTRICAL REPAIRS-CITY HALL	
			10744	ELECTRICAL REPAIRS-PSB	
			10740	ELECTRICAL REPAIRS-CRC/FITNESS 19	
Remit to: RIVERSIDE, CA					
	217688	06/24/2013	10762	ELECTRICAL REPAIRS-BETHUNE PARK	\$896.64
			10761	ELECTRICAL REPAIR- WOODLAND PARK	
			10760	ELECTRICAL REPAIR-RIDGECREST PARK	
Remit to: RIVERSIDE, CA					
	9623	06/17/2013	16546	WYCOM CHECK STOCK FOR A/P	\$503.44
Remit to: RIVERSIDE, CA					
					\$44,429.60



**City of Moreno Valley
Payment Register
For Period 6/1/2013 through 6/30/2013**

CHECKS UNDER \$25,000

<u>Vendor Name</u>	<u>Check/EFT Number</u>	<u>Payment Date</u>	<u>Inv Number</u>	<u>Invoice Description</u>	<u>Payment Amount</u>
Remit to: SAN DIEGO, CA					<u>FYTD:</u> \$2,125.05
AEI-CASCENGINEERING	217689	06/24/2013	0029397	PLAN CHECK SVCS-PWQMP-MAY13	\$472.50
Remit to: COLTON, CA					<u>FYTD:</u> \$22,346.50
AIR EXCHANGE INC	217535	06/10/2013	31215	MAINTENANCE & REPAIR OF PLYMOVENT-FS#6	\$701.90
Remit to: Fairfield, CA					<u>FYTD:</u> \$4,090.54
AIR EXCHANGE INC	217690	06/24/2013	31351	PLYMOVENT MAINT/REPAIR-FIRE STN 91	\$481.21
			31350	PLYMOVENT MAINT/REPAIR-FIRE STN 2	
Remit to: Fairfield, CA					<u>FYTD:</u> \$4,090.54
ALBERT A. WEBB ASSOCIATES	217608	06/17/2013	131025	WATER QUALITY TESTING & ANALYSIS - EDGEMONT WATER MASTER PLAN	\$440.00
Remit to: RIVERSIDE, CA					<u>FYTD:</u> \$31,460.90
ALEJANDRA DELGADO	217588	06/10/2013	1046292	REFUNDS FOR RENTALS	\$200.00
Remit to: MORENO VALLEY, CA					<u>FYTD:</u> \$200.00
ALICE KAREN RADER	217683	06/17/2013	MV2121109025	REFUND-CITATION DISMISSED/COURT FEE REIMBURSEMENT	\$457.50
Remit to: BANNING, CA					<u>FYTD:</u> \$457.50
ALLISON COLLINS	217652	06/17/2013	R13-058826	AS REFUND-RABIES & S/N DEPOSIT	\$95.00
Remit to: LONG BEACH, CA					<u>FYTD:</u> \$95.00
ALYSSA RAMIREZ	217684	06/17/2013	MV4120615011	REFUND-CITATION OVERPAYMENT	\$40.50
Remit to: RIVERSIDE, CA					<u>FYTD:</u> \$40.50



**City of Moreno Valley
Payment Register
For Period 6/1/2013 through 6/30/2013**

CHECKS UNDER \$25,000

<u>Vendor Name</u>	<u>Check/EFT Number</u>	<u>Payment Date</u>	<u>Inv Number</u>	<u>Invoice Description</u>	<u>Payment Amount</u>
AMBER FRANSIK	217642	06/17/2013	FUEL REIMB.	REIMBURSEMENT FOR FUEL DURING CPTED TRAINING- HENDERSON, NV.	\$74.04
Remit to: MORENO VALLEY, CA					FYTD: \$224.04
AMERICAN FORENSIC NURSES	9469	06/03/2013	63115	BLOOD DRAW SERVICE	\$6,739.32
			63044	BLOOD DRAW SERVICE	
			63045	BLOOD DRAW SERVICE	
			63114	BLOOD DRAW SERVICE	
Remit to: PALM SPRINGS, CA					FYTD: \$66,017.68
AMERICAN FORENSIC NURSES	9569	06/10/2013	63174	BLOOD DRAW SERVICE	\$3,420.60
			63149	BLOOD DRAW SERVICE	
			63173	BLOOD DRAW SERVICE	
Remit to: PALM SPRINGS, CA					FYTD: \$66,017.68
AMERICAN FORENSIC NURSES	9655	06/24/2013	63259	BLOOD DRAW SERVICE	\$2,927.64
			63257	BLOOD DRAW SERVICE	
			63258	BLOOD DRAW SERVICE	
			63232	BLOOD DRAW SERVICE	
			63020	BLOOD DRAW SERVICE	
Remit to: PALM SPRINGS, CA					FYTD: \$66,017.68
AMTECH ELEVATOR SERVICES	217692	06/24/2013	DVB65909613	ELEVATOR MAINT/REPAIR-EOC	\$1,727.92
			DVB32508001	ELEVATOR 5-YR FULL LOAD TEST-CITY HALL	
			DVB05044613	ELEVATOR MAINT/REPAIR-CITY HALL	



**City of Moreno Valley
Payment Register
For Period 6/1/2013 through 6/30/2013**

CHECKS UNDER \$25,000

<u>Vendor Name</u>	<u>Check/EFT Number</u>	<u>Payment Date</u>	<u>Inv Number</u>	<u>Invoice Description</u>	<u>Payment Amount</u>
Remit to: PASADENA, CA				<u>FYTD:</u>	\$6,297.48
ANGEL ORELLANA	217665	06/17/2013	1045321	REFUND VALLEY KIDS CAMP	\$97.00
Remit to: MORENO VALLEY, CA				<u>FYTD:</u>	\$97.00
ANGELA RODRIGUEZ	217668	06/17/2013	1048159	REFUND PEE WEE SOCCER	\$72.00
Remit to: MORENO VALLEY, CA				<u>FYTD:</u>	\$72.00
ANGELA SANCHEZ	217669	06/17/2013	1044752	REFUND FOR PEE WEE T-BALL	\$62.00
Remit to: MORENO VALLEY, CA				<u>FYTD:</u>	\$62.00
ARROWHEAD WATER	9624	06/17/2013	03E0029115144	WATER PURIFY RNTL UNIT-LIBRARY	\$103.64
			03E0029115359	WATER PURIFY RNTL UNIT-CRC	
			03E0029648037	WATER PURIFY RNTL UNIT-FIRE STN 91	
			03E0029115227	WATER PURIFY RNTL UNIT-SDA ANNEX	
Remit to: LOUISVILLE, KY				<u>FYTD:</u>	\$6,973.75
AT&T MOBILITY	217454	06/03/2013	872455379X050613	MCC CELLULAR PHONE SVC 4/7-5/6/13	\$91.82
Remit to: CAROL STREAM, IL				<u>FYTD:</u>	\$1,103.27
AT&T MOBILITY	217693	06/24/2013	872455379X060613	MCC CELLULAR PHONE SVC 5/7-6/6/13	\$91.82
Remit to: CAROL STREAM, IL				<u>FYTD:</u>	\$1,103.27
AT&T/MCI	217455	06/03/2013	4357828	LANDLINE PHONE SVC FOR GTF SATELLITE OFFICE	\$184.96
Remit to: CAROL STREAM, IL				<u>FYTD:</u>	\$2,213.08



**City of Moreno Valley
Payment Register
For Period 6/1/2013 through 6/30/2013**

CHECKS UNDER \$25,000

<u>Vendor Name</u>	<u>Check/EFT Number</u>	<u>Payment Date</u>	<u>Inv Number</u>	<u>Invoice Description</u>	<u>Payment Amount</u>
AU2 ENTERPRISES / RICARDO F. GOLDEN	217694	06/24/2013	539	LABOR FOR MCC SATELLITE REPAIRS	\$75.00
Remit to: RIVERSIDE, CA					
BACHER, GRACE	217489	06/03/2013	130601	RETIREE MED JUNE '13	\$255.43
Remit to: HEMET, CA					
BAKER & TAYLOR	217536	06/10/2013	D24NS7254R	AXIS 360 ANNUAL HOSTING, ACCESS & SVC FEES JUN'13-MAY'14	\$3,000.00
Remit to: ATLANTA, GA					
BAKER & TAYLOR	217695	06/24/2013	4010483603	E-BOOKS FOR CIRCULATION-LIBRARY	\$353.30
Remit to: ATLANTA, GA					
BAUTISTA, JOSEPH C.	9491	06/03/2013	130601	RETIREE MED JUNE '13	\$318.73
Remit to: FONTANA, CA					
BECKNER, PATRICK	9492	06/03/2013	130601	RETIREE MED MAR-MAY '13, PD JUNE '13	\$772.64
Remit to: MURRIETA, CA					
BELMUIDES, DEBRA	9493	06/03/2013	130601	RETIREE MED JUNE '13	\$318.73
Remit to: MORENO VALLEY, CA					
BEMUS LANDSCAPE, INC.	9570	06/10/2013	244294	LANDSCAPE MAINT-SCE & OLD LAKE DR	\$10,734.33
			244311	LANDSCAPE MAINT-ANIMAL SHELTER	
			244306	LANDSCAPE MAINT-MV UTILITY	
			244305	LANDSCAPE MAINT-PUBLIC LIBRARY	
			244292	LANDSCAPE MAINT-PAN AM SECTION/AQUEDUCT	



**City of Moreno Valley
Payment Register
For Period 6/1/2013 through 6/30/2013**

CHECKS UNDER \$25,000

<u>Vendor Name</u>	<u>Check/EFT Number</u>	<u>Payment Date</u>	<u>Inv Number</u>	<u>Invoice Description</u>	<u>Payment Amount</u>
BEMUS LANDSCAPE, INC.	9570	06/10/2013	244297	LANDSCAPE MAINT-BIKE AQUEDUCT	\$10,734.33
			244291	LANDSCAPE MAINT-NORTH AQUEDUCT	
			244290	LANDSCAPE MAINT-SOUTH AQUEDUCT "B"	
			244298	LANDSCAPE MAINT-SOUTH AQUEDUCT "A"	
			244308	LANDSCAPE MAINT-TOWNGATE BIKE AQUEDUCT	
			244310	LANDSCAPE MAINT-PSB	
			244307	LANDSCAPE MAINT-TOWNGATE	
			244293	LANDSCAPE MAINT-SENIOR CTR	
			244303	LANDSCAPE MAINT-ASES ADMIN BLDG	
			244302	LANDSCAPE MAINT-CITY YARD	
			244309	LANDSCAPE MAINT-ELECTRIC SUBSTATION	
			244304	LANDSCAPE MAINT-CRC	
Remit to: SAN CLEMENTE, CA					FYTD: \$218,149.62
BEMUS LANDSCAPE, INC.	217537	06/10/2013	244300	LANDSCAPE MAINT-VETERAN'S MEMORIAL	\$6,244.30
			244312	LANDSCAPE MAINT-CITY HALL	
			244295	LANDSCAPE MAINT-PATRIOT PARK	
			244296	LANDSCAPE MAINT-BAY AVE TO JFK AVE/AQUEDUCT	
			244313	LANDSCAPE MAINT-FIRE STATION #6	
			244301	LANDSCAPE MAINT-ANNEX 1	
Remit to: SAN CLEMENTE, CA					FYTD: \$218,149.62
BENESYST	9571	06/10/2013	0513288	COBRA ADMIN FEE	\$205.00
Remit to: MINNEAPOLIS, MN					FYTD: \$5,329.56



**City of Moreno Valley
Payment Register
For Period 6/1/2013 through 6/30/2013**

CHECKS UNDER \$25,000

<u>Vendor Name</u>	<u>Check/EFT Number</u>	<u>Payment Date</u>	<u>Inv Number</u>	<u>Invoice Description</u>	<u>Payment Amount</u>
BENESYST	9572	06/10/2013	0513148	FSA ADMIN COSTS	\$211.64
Remit to: MINNEAPOLIS, MN					
BENJAMIN POSADA	217747	06/24/2013	12194065	DUPLICATE PAYMENT	\$42.56
Remit to: RIVERSIDE, CA					
BLAIR, CHERYL	217734	06/24/2013	MAY-2013	INSTRUCTOR SVCS-BELLY DANCING CLASS	\$81.00
Remit to: RIVERSIDE, CA					
BMW MOTORCYCLES OF RIVERSIDE	217539	06/10/2013	6005621/1	MAINT & REPAIRS-NEW TRAFFIC MOTORCYCLES	\$252.93
Remit to: RIVERSIDE, CA					
BOOKLETTERS	217696	06/24/2013	RB3558	ANNUAL RENEWAL-LIBRARY WEB PAGE SERVICE 4/1/13-3/31/14	\$3,564.00
Remit to: COLUMBUS, OH					
BORDEAU, MYLING	217512	06/03/2013	6/10-6/13/13	TRAVEL PER DIEM FOR DRUG IMPAIRED DRIVER TRAINING COURSE	\$130.00
Remit to: MORENO VALLEY, CA					
BOX SPRINGS MUTUAL WATER COMPANY	217609	06/17/2013	05292013	WATER USAGE-ACCOUNT #721-1 ZONE E-1	\$99.56
Remit to: MORENO VALLEY, CA					
BRAUN BLAISING MCLAUGHLIN	217540	06/10/2013	14645	LEGAL SVCS-STREETLIGHT RATE CASE (CASL)	\$3,456.00
Remit to: SACRAMENTO, CA					
BRAUN BLAISING MCLAUGHLIN	217697	06/24/2013	14670	LEGAL SVCS-MVU-MAY13	\$8,562.00



City of Moreno Valley
Payment Register
 For Period 6/1/2013 through 6/30/2013

CHECKS UNDER \$25,000

<u>Vendor Name</u>	<u>Check/EFT Number</u>	<u>Payment Date</u>	<u>Inv Number</u>	<u>Invoice Description</u>	<u>Payment Amount</u>
BRAUN BLAISING MCLAUGHLIN	217697	06/24/2013	14671	LEGAL SVCS-STREETLIGHT RATE CASE (CASL)	\$8,562.00
			14644	LEGAL SVCS-MVU-APR13	
Remit to: SACRAMENTO, CA					<u>FYTD:</u> \$71,565.60
BRENDA VASQUEZ	217599	06/10/2013	R13-058318	AS REFUND-RABIES DEPOSIT	\$20.00
Remit to: PERRIS, CA					<u>FYTD:</u> \$20.00
BUCKINGHAM, STAN	217490	06/03/2013	130601	RETIREE MED JUNE '13	\$318.73
Remit to: TEMECULA, CA					<u>FYTD:</u> \$3,506.03
C & C GRADING & PAVING, INC	9625	06/17/2013	1630-4	CONSTRUCTION CONTRACT - SIP	\$4,393.75
Remit to: TEMECULA, CA					<u>FYTD:</u> \$256,235.77
CAIN, GREGORY	9494	06/03/2013	130601	RETIREE MED JUNE '13	\$318.73
Remit to: TAMPA, FL					<u>FYTD:</u> \$3,506.03
CALIFA GROUP	217456	06/03/2013	5253	PLAY & LEARN ISLAND-TAX/SHIPPING INCLUDED	\$1,500.00
Remit to: SAN MATEO, CA					<u>FYTD:</u> \$1,500.00
CALIFORNIA PROPERTY SPECIALISTS, INC	217605	06/10/2013	7057	CONSULTING SERVICES, ROW	\$3,675.00
Remit to: MISSION VIEJO, CA					<u>FYTD:</u> \$3,675.00
CALIFORNIA STATE ASSOCIATION OF COUNTIES	217541	06/10/2013	25468	ADVERTISEMENT-JOB POSTING	\$250.00
Remit to: SACRAMENTO, CA					<u>FYTD:</u> \$250.00

Item No. A.7



**City of Moreno Valley
Payment Register
For Period 6/1/2013 through 6/30/2013**

CHECKS UNDER \$25,000

<u>Vendor Name</u>	<u>Check/EFT Number</u>	<u>Payment Date</u>	<u>Inv Number</u>	<u>Invoice Description</u>	<u>Payment Amount</u>
CALIFORNIA STATE CONTROLLER'S OFFICE	217457	06/03/2013	UC130601	UNCLAIMED PROPERTY - PAYROLL	\$18.56
Remit to: SACRAMENTO, CA					<u>FYTD:</u> \$8,916.87
CALIFORNIA STATE CONTROLLER'S OFFICE	217513	06/03/2013	REPORT YEAR 2012	REMITTANCE OF UNCLAIMED A/P CHECKS TO SCO FOR REPORT YEAR 2012	\$8,898.31
Remit to: SACRAMENTO, CA					<u>FYTD:</u> \$8,916.87
CANNON, ANA M.	9495	06/03/2013	130601	RETIREE MED JUNE '13	\$318.73
Remit to: HASLET, TX					<u>FYTD:</u> \$3,506.03
CANON SOLUTIONS AMERICA, INC.	9656	06/24/2013	1103031201304151	COPIER SVC-JAN THRU MARCH 2013-POLICE	\$2,210.68
Remit to: BURLINGTON, NJ					<u>FYTD:</u> \$107,894.04
CARTER, ROSALYN	9496	06/03/2013	130601	RETIREE MED MAR-MAY '13, PD JUNE '13	\$956.19
Remit to: MORENO VALLEY, CA					<u>FYTD:</u> \$2,868.57
CASSIE BENDIX	217647	06/17/2013	1044980	REFUND VALLEY KIDS CAMP FOR ERIC AND MELODY	\$147.20
Remit to: MORENO VALLEY, CA					<u>FYTD:</u> \$147.20
CELLEBRITE USA, CORP	9573	06/10/2013	126630	SOFTWARE UPGRADE & 3 YEAR MAINTENANCE	\$6,662.73
Remit to: GLEN ROCK, NJ					<u>FYTD:</u> \$6,662.73
CEMEX	217542	06/10/2013	9426013310	PORTLAND CEMENT-MAINT & OP'S	\$1,265.24
			9426030346	PORTLAND CEMENT-MAINT & OP'S	
			9426053731	PORTLAND CEMENT-MAINT & OP'S	



**City of Moreno Valley
Payment Register
For Period 6/1/2013 through 6/30/2013**

CHECKS UNDER \$25,000

<u>Vendor Name</u>	<u>Check/EFT Number</u>	<u>Payment Date</u>	<u>Inv Number</u>	<u>Invoice Description</u>	<u>Payment Amount</u>
Remit to: PASADENA, CA				FYTD:	\$21,992.91
CENTRAL OCCUPATIONAL MEDICINE PROVIDERS	9574	06/10/2013	04-0314924	PRE-EMPLOYMENT PHYSICALS/DRUG TESTING	\$2,175.12
			04-0312736	PRE-EMPLOYMENT PHYSICALS/DRUG TESTING	
			04-0313048	PRE-EMPLOYMENT PHYSICALS/DRUG TESTING	
			04-0312733	PRE-EMPLOYMENT PHYSICALS/DRUG TESTING	
			04-0314963	PRE-EMPLOYMENT PHYSICALS/DRUG TESTING	
			01-0329858	PRE-EMPLOYMENT PHYSICALS/DRUG TESTING	
			04-0312731	PRE-EMPLOYMENT PHYSICALS/DRUG TESTING	
			04-0312728	PRE-EMPLOYMENT PHYSICALS/DRUG TESTING	
			04-0312725	PRE-EMPLOYMENT PHYSICALS/DRUG TESTING	
			04-0312723	PRE-EMPLOYMENT PHYSICALS/DRUG TESTING	
			04-0312495	PRE-EMPLOYMENT PHYSICALS/DRUG TESTING	
			04-0311527	PRE-EMPLOYMENT PHYSICALS/DRUG TESTING	
			04-0314700	PRE-EMPLOYMENT PHYSICALS/DRUG TESTING	
			04-0314790	PRE-EMPLOYMENT PHYSICALS/DRUG TESTING	
			04-0312759	PRE-EMPLOYMENT PHYSICALS/DRUG TESTING	
			04-0314412	PRE-EMPLOYMENT PHYSICALS/DRUG TESTING	
			04-0313194	PRE-EMPLOYMENT PHYSICALS/DRUG TESTING	
			05-0336876	PRE-EMPLOYMENT PHYSICALS/DRUG TESTING	
			01-0329859	PRE-EMPLOYMENT PHYSICALS/DRUG TESTING	
			04-0314964	PRE-EMPLOYMENT PHYSICALS/DRUG TESTING	
			04-0313436	PRE-EMPLOYMENT PHYSICALS/DRUG TESTING	
			04-0314968	PRE-EMPLOYMENT PHYSICALS/DRUG TESTING	

Item No. A.7



**City of Moreno Valley
Payment Register
For Period 6/1/2013 through 6/30/2013**

CHECKS UNDER \$25,000

<u>Vendor Name</u>	<u>Check/EFT Number</u>	<u>Payment Date</u>	<u>Inv Number</u>	<u>Invoice Description</u>	<u>Payment Amount</u>
CENTRAL OCCUPATIONAL MEDICINE PROVIDERS	9574	06/10/2013	04-0314952	PRE-EMPLOYMENT PHYSICALS/DRUG TESTING	\$2,175.12
			04-0312757	PRE-EMPLOYMENT PHYSICALS/DRUG TESTING	
			04-0312734	PRE-EMPLOYMENT PHYSICALS/DRUG TESTING	
			04-0312729	PRE-EMPLOYMENT PHYSICALS/DRUG TESTING	
			04-0311526	PRE-EMPLOYMENT PHYSICALS/DRUG TESTING	
			04-0313437	PRE-EMPLOYMENT PHYSICALS/DRUG TESTING	
			05-0337012	PRE-EMPLOYMENT PHYSICALS/DRUG TESTING	
			01-0329856	PRE-EMPLOYMENT PHYSICALS/DRUG TESTING	
			04-0312850	PRE-EMPLOYMENT PHYSICALS/DRUG TESTING	
			05-0336877	PRE-EMPLOYMENT PHYSICALS/DRUG TESTING	
			04-0314772	PRE-EMPLOYMENT PHYSICALS/DRUG TESTING	
			04-0314789	PRE-EMPLOYMENT PHYSICALS/DRUG TESTING	
			04-0314784	PRE-EMPLOYMENT PHYSICALS/DRUG TESTING	
			04-0311525	PRE-EMPLOYMENT PHYSICALS/DRUG TESTING	
			04-0313435	PRE-EMPLOYMENT PHYSICALS/DRUG TESTING	
			04-0314925	PRE-EMPLOYMENT PHYSICALS/DRUG TESTING	
			04-0312724	PRE-EMPLOYMENT PHYSICALS/DRUG TESTING	
			04-0314969	PRE-EMPLOYMENT PHYSICALS/DRUG TESTING	
			04-0314771	PRE-EMPLOYMENT PHYSICALS/DRUG TESTING	
			04-0314785	PRE-EMPLOYMENT PHYSICALS/DRUG TESTING	
			04-0312735	PRE-EMPLOYMENT PHYSICALS/DRUG TESTING	
			04-0312758	PRE-EMPLOYMENT PHYSICALS/DRUG TESTING	
			04-0313193	PRE-EMPLOYMENT PHYSICALS/DRUG TESTING	
			04-0314413	PRE-EMPLOYMENT PHYSICALS/DRUG TESTING	



**City of Moreno Valley
Payment Register
For Period 6/1/2013 through 6/30/2013**

CHECKS UNDER \$25,000

<u>Vendor Name</u>	<u>Check/EFT Number</u>	<u>Payment Date</u>	<u>Inv Number</u>	<u>Invoice Description</u>	<u>Payment Amount</u>
CENTRAL OCCUPATIONAL MEDICINE PROVIDERS	9574	06/10/2013	04-0312496	PRE-EMPLOYMENT PHYSICALS/DRUG TESTING	\$2,175.12
			05-0336878	PRE-EMPLOYMENT PHYSICALS/DRUG TESTING	
			04-0312730	PRE-EMPLOYMENT PHYSICALS/DRUG TESTING	
			04-0311528	PRE-EMPLOYMENT PHYSICALS/DRUG TESTING	
			04-0311491	PRE-EMPLOYMENT PHYSICALS/DRUG TESTING	
			04-0311492	PRE-EMPLOYMENT PHYSICALS/DRUG TESTING	
			04-0312401	PRE-EMPLOYMENT PHYSICALS/DRUG TESTING	
			04-0312123	PRE-EMPLOYMENT PHYSICALS/DRUG TESTING	
			04-0314411	PRE-EMPLOYMENT PHYSICALS/DRUG TESTING	
			04-0314953	PRE-EMPLOYMENT PHYSICALS/DRUG TESTING	
			04-0314923	PRE-EMPLOYMENT PHYSICALS/DRUG TESTING	
			04-0314699	PRE-EMPLOYMENT PHYSICALS/DRUG TESTING	
			04-0314783	PRE-EMPLOYMENT PHYSICALS/DRUG TESTING	
			04-0314970	PRE-EMPLOYMENT PHYSICALS/DRUG TESTING	
			04-0314773	PRE-EMPLOYMENT PHYSICALS/DRUG TESTING	
			04-0314788	PRE-EMPLOYMENT PHYSICALS/DRUG TESTING	
Remit to: RIVERSIDE, CA					FYTD: \$11,246.12
CESAR CARMARGO	217676	06/17/2013	MV3121109053	REFUND-CITATION OVERPAYMENT	\$65.00
Remit to: MORENO VALLEY, CA					FYTD: \$65.00
CHAPMAN, STEVE	217491	06/03/2013	130601	RETIREE MED JUNE '13	\$318.73
Remit to: REDLANDS, CA					FYTD: \$3,506.03
CHAPPELL, ISAAC	9497	06/03/2013	130601	RETIREE MED JUNE '13	\$318.73



**City of Moreno Valley
Payment Register
For Period 6/1/2013 through 6/30/2013**

CHECKS UNDER \$25,000

<u>Vendor Name</u>	<u>Check/EFT Number</u>	<u>Payment Date</u>	<u>Inv Number</u>	<u>Invoice Description</u>	<u>Payment Amount</u>
Remit to: MORENO VALLEY, CA					
CHJ INCORPORATED	217604	06/10/2013	86953	CONSULTING SERVICES, GEOTECHNICAL - PERRIS BLVD	\$3,506.03
			86927	CONSULTING SERVICES, GEOTECHNICAL - PERRIS BLVD	\$12,405.00
			86897	CONSULTING SERVICES, GEOTECHNICAL - PERRIS BLVD	
Remit to: COLTON, CA					
CINTAS CORPORATION	9471	06/03/2013	150841729	UNIFORM RNTL SVC-ST SWEEPING	\$610.64
			150841730	UNIFORM RNTL SVC-DRAIN MAINT	
			150841731	UNIFORM RNTL SVC-ST MAINT	
			150100650	UNIFORM RNTL SVC-DRAIN MAINT	
			150841723	UNIFORM RNTL SVC-TRAFFIC SIGNAL	
			150846180	UNIFORM RNTL SVC-TRAFFIC SIGNAL	
			150846181	UNIFORM RNTL SVC-ST SIGNS/STRIPING	
			150846186	UNIFORM RNTL SVC-ST SWEEPING	
			150846187	UNIFORM RNTL SVC-DRAIN MAINT	
			150841727	UNIFORM RNTL SVC-ST TREE MAINT	
			150100647	UNIFORM RNTL SVC-ST TREE MAINT	
			150841732	UNIFORM RNTL SVC-CONCRETE MAINT	
			150846188	UNIFORM RNTL SVC-ST MAINT	
			150846189	UNIFORM RNTL SVC-CONCRETE MAINT	
			150100652	UNIFORM RNTL SVC-CONCRETE MAINT	
			150100645	UNIFORM RNTL SVC-CONCRETE MAINT	
			150100649	UNIFORM RNTL SVC-ST SWEEPING	
			150841725	UNIFORM RNTL SVC-TRAFFITI RMVL	



**City of Moreno Valley
Payment Register
For Period 6/1/2013 through 6/30/2013**

CHECKS UNDER \$25,000

<u>Vendor Name</u>	<u>Check/EFT Number</u>	<u>Payment Date</u>	<u>Inv Number</u>	<u>Invoice Description</u>	<u>Payment Amount</u>
CINTAS CORPORATION	9471	06/03/2013	150846184	UNIFORM RNTL SVC-ST TREE MAINT	\$610.64
			150846182	UNIFORM RNTL SVC-GRAFFITI RMVL	
			150100642	UNIFORM RNTL SVC-PURCHASING	
			150846179	UNIFORM RNTL SVC-PURCHASING	
			150841722	UNIFORM RNTL SVC-PURCHASING	
			150837201	UNIFORM RNTL SVC-PURCHASING	
			150100644	UNIFORM RNTL SVC-ST SIGNS/STRIPING	
			150100643	UNIFORM RNTL SVC-TRAFFIC SIGNAL	
			150841726	UNIFORM RNTL SVC-VEHICLE MAINT	
			150841724	UNIFORM RNTL SVC-ST SIGNS/STRIPING	
			150100651	UNIFORM RNTL SVC-ST MAINT	
Remit to: ONTARIO, CA					FYTD: \$17,027.06
CINTAS CORPORATION	9626	06/17/2013	150769560	UNIFORM RNTL SVC-FACILITIES	\$67.64
			150702028	UNIFORM RNTL SVC-FACILITIES	
			150760564	UNIFORM RNTL SVC-FACILITIES	
			150832740	UNIFORM RNTL SVC-GOLF COURSE	
Remit to: ONTARIO, CA					FYTD: \$17,027.06
CINTAS CORPORATION	9657	06/24/2013	150109599	UNIFORM RNTL SVC-FACILITIES	\$531.69
			150113678	UNIFORM RNTL SVC-FACILITIES	
			150105110	UNIFORM RNTL SVC-FACILITIES	
			150100646	UNIFORM RNTL SVC-VEHICLE MAINT	
			150109594	UNIFORM RNTL SVC-CFD #1	
			150846183	UNIFORM RNTL SVC-VEHICLE MAINT	

Item No. A.7



**City of Moreno Valley
Payment Register
For Period 6/1/2013 through 6/30/2013**

CHECKS UNDER \$25,000

<u>Vendor Name</u>	<u>Check/EFT Number</u>	<u>Payment Date</u>	<u>Inv Number</u>	<u>Invoice Description</u>	<u>Payment Amount</u>
CINTAS CORPORATION	9657	06/24/2013	150105105	UNIFORM RNTL SVC-CFD #1	\$531.69
			150105111	UNIFORM RNTL SVC-GOLF COURSE	
			150117188	UNIFORM RNTL SVC-FACILITIES	
			150105098	UNIFORM RNTL SVC-PARK MAINT	
			150109600	UNIFORM RNTL SVC-GOLF COURSE	
			150113666	UNIFORM RNTL SVC-PARK MAINT	
			150113679	UNIFORM RNTL SVC-GOLF COURSE	
			150117176	UNIFORM RNTL SVC-PARK MAINT	
			150120702	UNIFORM RNTL SVC-FACILITIES	
			150109587	UNIFORM RNTL SVC-PARK MAINT	
Remit to: ONTARIO, CA					FYTD: \$17,027.06
CITY OF MORENO VALLEY VEBA TRUST	9472	06/03/2013	2013-00000106	4020 - EXEC VEBA *	\$3,362.87
Remit to: MORENO VALLEY, CA					FYTD: \$184,940.40
CITY OF MORENO VALLEY VEBA TRUST	9627	06/17/2013	2013-00000110	4020 - EXEC VEBA *	\$6,897.50
Remit to: MORENO VALLEY, CA					FYTD: \$184,940.40
CLS LANDSCAPE MANAGEMENT, INC	217587	06/10/2013	BL#01569-YR2013	REFUND OF OVERPAYMENT FOR B/L#01569	\$95.61
Remit to: CHINO, CA					FYTD: \$95.61
COLD STAR, INC.	217735	06/24/2013	05152013	SPECIAL EVENTY TRAILER W/ 38LB ICE-JULY 4TH FESTIVAL	\$480.60
Remit to: CHINO HILLS, CA					FYTD: \$480.60



**City of Moreno Valley
Payment Register
For Period 6/1/2013 through 6/30/2013**

CHECKS UNDER \$25,000

<u>Vendor Name</u>	<u>Check/EFT Number</u>	<u>Payment Date</u>	<u>Inv Number</u>	<u>Invoice Description</u>	<u>Payment Amount</u>
COLONIAL SUPPLEMENTAL INSURANCE	217514	06/03/2013	7133069-0601433	SUPPLEMENTAL INSURANCE	\$6,613.14
Remit to: COLUMBIA, SC					
COMMUNITY HEALTH CHARITIES	217458	06/03/2013	2013-00000091	8725 - CH CHARITY	\$94.00
Remit to: COSTA MESA, CA					
COMMUNITY HEALTH CHARITIES	217610	06/17/2013	2013-00000111	8725 - CH CHARITY	\$94.00
Remit to: COSTA MESA, CA					
CONTINENTAL WESTERN TRANSPORTATION	217543	06/10/2013	0104972-IN	ASPHALTIC MATERIALS-SURFACE RECYCLING PROJ	\$11,148.19
Remit to: SAN DIEGO, CA					
CONTINUING EDUCATION OF THE BAR	217544	06/10/2013	10148106	BOOKS, PUBLICATIONS & AUDIOVISUAL-LAW LIBRARY	\$162.31
Remit to: OAKLAND, CA					
COSTCO	217545	06/10/2013	19637	SNACK SUPPLIES FOR SKATE PARK	\$2,095.78
			19635	SNACK SUPPLIES FOR "A CHILD'S PLACE"	
Remit to: MORENO VALLEY, CA					
COUNSELING TEAM, THE	217611	06/17/2013	21156	EMPLOYEE ASSISTANCE SVCS	\$1,250.00
Remit to: SAN BERNARDINO, CA					
COUNTRY SQUIRE ESTATES	217698	06/24/2013	MAY 2013	REFUND-UTILITY USER TAX EXEMPTIONS	\$48.04
FYTD: \$77,187.69					
FYTD: \$4,674.00					
FYTD: \$4,674.00					
FYTD: \$25,382.08					
FYTD: \$1,788.88					
FYTD: \$16,121.13					
FYTD: \$31,750.00					



**City of Moreno Valley
Payment Register
For Period 6/1/2013 through 6/30/2013**

CHECKS UNDER \$25,000

<u>Vendor Name</u>	<u>Check/EFT Number</u>	<u>Payment Date</u>	<u>Inv Number</u>	<u>Invoice Description</u>	<u>Payment Amount</u>
Remit to: ONTARIO, CA				<u>FYTD:</u>	\$1,048.73
COUNTY OF RIVERSIDE - RMAP	217546	06/10/2013	9990085000-1304	RADIO COMM. SERVICES FOR PD MOTORCYCLES	\$983.50
Remit to: RIVERSIDE, CA				<u>FYTD:</u>	\$654,277.25
COUNTY OF RIVERSIDE - RMAP	217612	06/17/2013	9990170000-1304	VPN CONNECTION FOR CODE ENFORCEMENT STAFF	\$28.84
Remit to: RIVERSIDE, CA				<u>FYTD:</u>	\$654,277.25
COUNTY OF RIVERSIDE 1	217736	06/24/2013	PU0000002833	JANITORIAL ITEMS FOR STATION EXPLORERS	\$1,459.74
Remit to: MORENO VALLEY, CA				<u>FYTD:</u>	\$11,051.05
CRIME SCENE STERI-CLEAN, LLC	9576	06/10/2013	32027	BIOHAZARD CLEANING SERVICES FOR PD-4/28/13 TRAFFIC ACCIDENT	\$750.00
Remit to: RANCHO CUCAMONGA, CA				<u>FYTD:</u>	\$8,250.00
DALE, KATHLEEN	9498	06/03/2013	130601	RETIREE MED JUNE '13	\$318.73
Remit to: MORENO VALLEY, CA				<u>FYTD:</u>	\$3,506.03
DANIEL TELLEZ	217748	06/24/2013	1049519/1049518	REFUNDS FOR RENTALS	\$828.15
Remit to: MORENO VALLEY, CA				<u>FYTD:</u>	\$828.15
DANIELLE PAGE	217682	06/17/2013	MV3130405032	REFUND-CITATION DISMISSED	\$57.50
Remit to: RIVERSIDE, CA				<u>FYTD:</u>	\$57.50
DATA TICKET, INC.	9473	06/03/2013	46793MS 46214	MAINTENANCE/SUPPORT-MAR13 ADMIN CITATION PROCESSING-B&S-MAR13	\$1,516.45



**City of Moreno Valley
Payment Register
For Period 6/1/2013 through 6/30/2013**

CHECKS UNDER \$25,000

<u>Vendor Name</u>	<u>Check/EFT Number</u>	<u>Payment Date</u>	<u>Inv Number</u>	<u>Invoice Description</u>	<u>Payment Amount</u>
DATA TICKET, INC.	9473	06/03/2013	46790MS	MAINTENANCE/SUPPORT-APR13	\$1,516.45
Remit to: NEWPORT BEACH, CA					
DATA TICKET, INC.	9659	06/24/2013	47282	NPDES BUSINESS INSPECTION SVCS-MAY13	\$3,705.44
			47294TPC	THIRD PARTY COLLECTIONS-B & S-MAY13	
			46713	NPDES BUSINESS INSPECTION SVCS-APR13	
			47296	ADMIN CITATION PROCESSING-PD-MAY13	
			47344MS	MAINTENANCE/SUPPORT-MAY13	
			47294	ADMIN CITATION PROCESSING-B & S-MAY13	
Remit to: NEWPORT BEACH, CA					
DATAQUICK CORPORATE HEADQUARTERS	217700	06/24/2013	B1-2167039	ONLINE SOFTWARE SUBSCRIPTION-POP UNIT	\$130.50
Remit to: LOS ANGELES, CA					
DAVID EVERITT	217494	06/03/2013	130601	RETIREE MED JUNE '13	\$318.73
Remit to: HEMET, CA					
DAVID LOZANO	217592	06/10/2013	R13-061978	AS REFUND-TRAP DEPOSIT	\$50.00
Remit to: MORENO VALLEY, CA					
DAVID MUSSER	217741	06/24/2013	JUN-2013	INSTRUCTOR SVCS-WATERCOLOR TECHNIQUE CLASS	\$420.00
Remit to: MENIFEE, CA					
DEBINAIRE COMPANY	217701	06/24/2013	139028	BOILER REPAIRS-WO#130934-CITY HALL	\$1,409.40
			139637	BOILER REPAIRS-WO#130936-PSB	
FYTD: \$194,363.34					
FYTD: \$1,566.00					
FYTD: \$318.73					
FYTD: \$50.00					
FYTD: \$50.00					
FYTD: \$4,998.00					

Item No. A.7



**City of Moreno Valley
Payment Register
For Period 6/1/2013 through 6/30/2013**

CHECKS UNDER \$25,000

<u>Vendor Name</u>	<u>Check/EFT Number</u>	<u>Payment Date</u>	<u>Inv Number</u>	<u>Invoice Description</u>	<u>Payment Amount</u>
Remit to: CORONA, CA					<u>FYTD:</u> \$5,746.50
DELTA DENTAL OF CALIFORNIA	9558	06/03/2013	BE000555703	EMPLOYEE DENTAL INSURANCE	\$10,743.39
Remit to: SAN FRANCISCO, CA					<u>FYTD:</u> \$125,583.09
DELTACARE USA	217737	06/24/2013	5388027	EMPLOYEE DENTAL INSURANCE	\$5,379.11
Remit to: LOS ANGELES, CA					<u>FYTD:</u> \$67,458.88
DENNIS GRUBB & ASSOCIATES, LLC	9577	06/10/2013	1190	PLAN REVIEW SVCS-FIRE PREVENTION	\$6,500.00
Remit to: MIRA LOMA, CA					<u>FYTD:</u> \$121,565.00
DENNY SHOR	217529	06/03/2013	05212013	REIMB-SAFE ROUTES TO SCHOOL (SR2S) PROGRAM EXPEND.	\$341.90
Remit to: MORENO VALLEY, CA					<u>FYTD:</u> \$341.90
DMC DESIGN GROUP, INC	9660	06/24/2013	2013-057	CONSULTING SERVICES, DESIGN - HEACOCK EXTENSION	\$22,955.00
Remit to: CORONA, CA					<u>FYTD:</u> \$171,297.87
DOLORES GRANILLO	217680	06/17/2013	MV2120307018	REFUND-CITATION OVERPAYMENT	\$115.00
Remit to: PERRIS, CA					<u>FYTD:</u> \$115.00
DOMINICK GARCIA	217656	06/17/2013	1036071	REFUND PEE WEE TENNIS	\$77.00
Remit to: MORENO VALLEY, CA					<u>FYTD:</u> \$77.00
DORY, ALLEEN F.	217492	06/03/2013	130601	RETIREE MED JUNE '13	\$146.32
Remit to: HEMET, CA					<u>FYTD:</u> \$3,206.67
DUVAL, ROBERTA	217459	06/03/2013	04272013	CPR & FIRST AID TRAINING-SECURITY GUARD B. CORNWELL	\$45.00



**City of Moreno Valley
Payment Register
For Period 6/1/2013 through 6/30/2013**

CHECKS UNDER \$25,000

<u>Vendor Name</u>	<u>Check/EFT Number</u>	<u>Payment Date</u>	<u>Inv Number</u>	<u>Invoice Description</u>	<u>Payment Amount</u>
Remit to: SUN CITY, CA					
DUVAL, ROBERTA	217738	06/24/2013	JUN-2013	INSTRUCTOR SVCS-CPR CLASS	\$191.20
Remit to: SUN CITY, CA					
E.R. BLOCK PLUMBING & HEATING, INC.	9578	06/10/2013	112020	BACKFLOW DEVICE TESTING-NPDES-ADDL.WORK	\$1,160.64
Remit to: RIVERSIDE, CA					
E.R. BLOCK PLUMBING & HEATING, INC.	9628	06/17/2013	112058	REPLACED STOLEN BACKFLOW-ZONE E-1	\$17,784.48
			1120951	REPLACED STOLEN BACKFLOW-T16769	
			112182	REPLACED BACKFLOW-T16769	
			112060	REPLACED STOLEN BACKFLOW-ZONE E-15	
			112428	INSTALL BACKFLOW REPAIR KITS-PARKS-BAY AVE	
			112061	REPLACED STOLEN BACKFLOW-T22371	
			112365	BACKFLOW DEVICE TESTS-VRS LOCATIONS	
			112425	REPLACED STOLEN BACKFLOW-T19141	
			112184	REPLACED BACKFLOW-T27526	
			1120941	REPLACED STOLEN BACKFLOW-T20525	
			112183	REPLACED BACKFLOW-ZONE E-2	
			112097	REPLACED STOLEN BACKFLOW-T19852	
Remit to: RIVERSIDE, CA					
EASTERN MUNICIPAL WATER DISTRICT	217547	06/10/2013	MAY-13	6/10/13 WATER CHARGES	\$9,816.35
Remit to: RIVERSIDE, CA					
					\$93,221.98

Item No. A.7



**City of Moreno Valley
Payment Register
For Period 6/1/2013 through 6/30/2013**

CHECKS UNDER \$25,000

<u>Vendor Name</u>	<u>Check/EFT Number</u>	<u>Payment Date</u>	<u>Inv Number</u>	<u>Invoice Description</u>	<u>Payment Amount</u>
Remit to: PERRIS, CA				<u>FYTD:</u>	\$1,504,961.70
EDDIE GARCIA	217657	06/17/2013	1044545	REFUND MEMORIAL DAY FORTBALL TOURNAMENT	\$202.00
Remit to: MORENO VALLEY, CA				<u>FYTD:</u>	\$202.00
EDGELANE MOBILE PARK	9661	06/24/2013	MAY 2013	REFUND-UTILITY USER TAX EXEMPTIONS	\$15.09
Remit to: LOS ANGELES, CA				<u>FYTD:</u>	\$175.59
EGGERSTEN, ANNE	217493	06/03/2013	130601	RETIREE MED JUNE '13	\$255.43
Remit to: RANCHO MIRAGE, CA				<u>FYTD:</u>	\$3,134.73
ENCO UTILITY SERVICES MORENO VALLEY LLC	9629	06/17/2013	40-221-15	WORK AUTHORIZATION 40-221	\$13,360.51
			40-285-02	WORK AUTHORIZATION 40-285-02	
			40-273A-08	WORK AUTHORIZATION 40-273A-08	
			40-284-03	WORK AUTHORIZATION 40-284	
			40-254B-11	ENCO FEES FOR PROFESSIONAL SERVICES - CACTUS/NASON	
			40-287-02	WORK AUTHORIZATION 40-287	
			40-247B-07	WORK AUTHORIZATION 40-247B	
			40-257B-03	WORK AUTHORIZATION 40-257B	
			40-256B-11	ENCO FEES FOR PROFESSIONAL SERVICES - CACTUS/NASON	
			40-280A-01	WORK AUTHORIZATION 40-280A	
Remit to: ANAHEIM, CA				<u>FYTD:</u>	\$2,361,112.79
ERICICA JAMES	217526	06/03/2013	1040733	REFUND FOR PICNIC SHELTER	\$64.00
Remit to: MORENO VALLEY, CA				<u>FYTD:</u>	\$64.00



**City of Moreno Valley
Payment Register
For Period 6/1/2013 through 6/30/2013**

CHECKS UNDER \$25,000

<u>Vendor Name</u>	<u>Check/EFT Number</u>	<u>Payment Date</u>	<u>Inv Number</u>	<u>Invoice Description</u>	<u>Payment Amount</u>
ESGIL CORPORATION	9474	06/03/2013	04133387	PLAN CHECK SVCS-B&S-APR13	\$1,297.50
Remit to: SAN DIEGO, CA					
ESI ACQUISITION, INC.	9630	06/17/2013	INV10271	WEB EOC PROF/MAPR SOFTWARE SUPPRT-TECH SVCS	\$8,800.00
Remit to: AUGUSTA, GA					
ESQUIVEK GUILLERMO	217659	06/17/2013	1047398	REFUND FOR SOCCER MEETING 23724	\$100.00
Remit to: HEMET, CA					
EVANS ENGRAVING & AWARDS	9579	06/10/2013	50713-2	EMPLOYEE RETIREMENT PLAQUES-PARK MAINT	\$151.20
			41813-9	PLANNING COMMISSIONER NAME PLATES	
			52113-21	PLANNING COMMISSIONER PLAQUE	
			82813-25	SERVICE AWARDS-EMPLOYEE OF THE QTR	
Remit to: MORENO VALLEY, CA					
EXCEL LANDSCAPE, INC	217614	06/17/2013	76763	LANDSCAPE MAINT-NPDES WQCB-ADDL WORK	\$17,580.64
			76766	LANDSCAPE MAINT-ZONE E-7 ADDL WORK	
			76765	LANDSCAPE MAINT-ZONE E-7 ADDL WORK	
			76764	LANDSCAPE MAINT-ZONE E-7 ADDL WORK	
			76820	LANDSCAPE MAINT-NPDES WQCB-MAY13	
			76813	LANDSCAPE MAINT-ZONE E-7-MAY13	
			76488	LANDSCAPE MAINT-WQCB	
Remit to: CORONA, CA					
FAITH HANG	217660	06/17/2013	1036168	REFUND JUNIOR TENNIS	\$79.00
FYTD: \$119,253.28					



City of Moreno Valley
Payment Register
 For Period 6/1/2013 through 6/30/2013

CHECKS UNDER \$25,000

<u>Vendor Name</u>	<u>Check/EFT Number</u>	<u>Payment Date</u>	<u>Inv Number</u>	<u>Invoice Description</u>	<u>Payment Amount</u>
Remit to: MORENO VALLEY, CA					<u>FYTD:</u> \$79.00
FEENSTRA, JOHN	9499	06/03/2013	130601	RETIREE MED JUNE '13	\$361.25
Remit to: REDLANDS, CA					<u>FYTD:</u> \$3,973.75
FIRST AMERICAN CORE LOGIC, INC.	9475	06/03/2013	80846172	ACCESS TO REALQUEST ONLINE IMAGING	\$300.00
Remit to: SANTA ANA, CA					<u>FYTD:</u> \$7,680.00
FIRST AMERICAN CORE LOGIC, INC.	217461	06/03/2013	80846174	ACCESS TO REALQUEST ONLINE IMAGING	\$340.00
Remit to: DALLAS, TX					<u>FYTD:</u> \$7,680.00
FIRST CAL INDUSTRIAL LLC	217678	06/17/2013	CK#210484	REISSUE UNCLAIMED CK#210484 DTD 12/5/11	\$4,702.20
Remit to: EL SEGUNDO, CA					<u>FYTD:</u> \$4,702.20
FIRST CHOICE SERVICES	9476	06/03/2013	524835	EMPLOYEE PAID COFFEE SVC-TS ANNEX	\$107.01
Remit to: ONTARIO, CA					<u>FYTD:</u> \$8,771.03
FIRST CHOICE SERVICES	9580	06/10/2013	524849	EMPLOYEE PAID COFFEE SVC-CITY HALL	\$181.01
Remit to: ONTARIO, CA					<u>FYTD:</u> \$8,771.03
FIRST CHOICE SERVICES	9631	06/17/2013	526275	EMPLOYEE PAID COFFEE SVC-CITY HALL	\$433.81
			526272	EMPLOYEE PAID COFFEE SVC-CITY HALL	
			525800	EMPLOYEE PAID COFFEE SVC-CITY HALL	
Remit to: ONTARIO, CA					<u>FYTD:</u> \$8,771.03
FIRST CHOICE SERVICES	9664	06/24/2013	526264	EMPLOYEE PAID COFFEE SVC-CITY YARD	\$77.28



**City of Moreno Valley
Payment Register
For Period 6/1/2013 through 6/30/2013**

CHECKS UNDER \$25,000

<u>Vendor Name</u>	<u>Check/EFT Number</u>	<u>Payment Date</u>	<u>Inv Number</u>	<u>Invoice Description</u>	<u>Payment Amount</u>
Remit to: ONTARIO, CA				<u>FYTD:</u>	\$8,771.03
FIRST INDUSTRIAL, LP	217601	06/10/2013	CFD#7-IA2	REFUND-CFD#7-IMPROVEMENT AREA #2 TRUST ACCT. CLOSED	\$2,550.50
Remit to: EL SEGUNDO, CA				<u>FYTD:</u>	\$2,550.50
FIRST INDUSTRIAL, LP	217679	06/17/2013	CK#210485	REISSUE UNCLAIMED CK#210485 DTD 12/5/11	\$4,684.20
Remit to: EL SEGUNDO, CA				<u>FYTD:</u>	\$4,684.20
FOSTER, NANCY A.	9500	06/03/2013	130601	RETIREE MED JUNE '13	\$318.73
Remit to: GRASS VALLEY, CA				<u>FYTD:</u>	\$3,506.03
FOSTER, ZACHARY F.	9501	06/03/2013	130601	RETIREE MED JUNE '13	\$318.73
Remit to: GRASS VALLEY, CA				<u>FYTD:</u>	\$2,868.57
FR/CAL MORENO VALLEY, LLC	217589	06/10/2013	B1001939	REFUND-UNUSED DEPOSIT-T&M PROJ-NANDINA DIST. CTR & PLAN CK FEES	\$12,090.28
Remit to: LOS ANGELES, CA				<u>FYTD:</u>	\$12,090.28
FRANCHISE TAX BOARD	217462	06/03/2013	2013-00000107	1015 - GARNISHMENT - CREDITOR %*	\$311.03
Remit to: SACRAMENTO, CA				<u>FYTD:</u>	\$7,844.68
FRANCHISE TAX BOARD	217615	06/17/2013	2013-00000112	1015 - GARNISHMENT - CREDITOR %	\$290.00
Remit to: SACRAMENTO, CA				<u>FYTD:</u>	\$7,844.68
G/M BUSINESS INTERIORS, INC.	217463	06/03/2013	0094211-IN	ANNEX 1 RECONFIGURATOR-FURNITURE PARTS	\$4,987.52
Remit to: RIVERSIDE, CA				<u>FYTD:</u>	\$224,259.55
G/M BUSINESS INTERIORS, INC.	217548	06/10/2013	0093512-IN	DELIVER/SETUP OF RENTAL FURNITURE AT ANNEX 4	\$21,936.98



**City of Moreno Valley
Payment Register
For Period 6/1/2013 through 6/30/2013**

CHECKS UNDER \$25,000

<u>Vendor Name</u>	<u>Check/EFT Number</u>	<u>Payment Date</u>	<u>Inv Number</u>	<u>Invoice Description</u>	<u>Payment Amount</u>
Remit to: RIVERSIDE, CA				<u>FYTD:</u>	\$224,259.55
GABRIELA CERVANTES	217650	06/17/2013	P13-035	REFUND-CANCELLED PLANNING APPLICATION	\$666.40
Remit to: MORENO VALLEY, CA				<u>FYTD:</u>	\$666.40
GALLS INC., INLAND UNIFORM	9665	06/24/2013	317365	UNIFORMS-PARK RANGERS	\$729.97
Remit to: PASADENA, CA				<u>FYTD:</u>	\$5,763.20
GARDNER COMPANY, INC.	217464	06/03/2013	1854	HVAC PREVENTIVE MAINT-LIBRARY-2ND QTR	\$1,375.00
Remit to: MURRIETA, CA				<u>FYTD:</u>	\$5,620.79
GENERAL SECURITY SERVICES, INC.	9477	06/03/2013	173935	SECURITY SVCS-CITY HALL 5/13-5/16/13	\$429.52
			173937	SECURITY SVCS-LIBRARY 5/18/13	
Remit to: WILMINGTON, CA				<u>FYTD:</u>	\$53,863.33
GENERAL SECURITY SERVICES, INC.	9581	06/10/2013	173924	SECURITY SVCS-SENIOR CTR RENTALS-5/18/13	\$1,576.19
			173996	SECURITY SVCS-CRC 5/20-5/23/13	
			173999	SECURITY SVCS-LIBRARY-5/25/13	
			173980	SECURITY SVCS-TOWNGATE-5/25/13	
			173995	SECURITY SVCS-CITY HALL 5/20-5/23/13	
			173998	SECURITY SVCS-SENIOR CTR RENTALS-5/19/13	
			173921	SECURITY SVCS-TOWNGATE-5/18/13	
			174035	SECURITY SVCS-CRC SPECIAL EVENTS 5/24/13	
			173936	SECURITY SVCS-CRC 5/13-5/16/13	



**City of Moreno Valley
Payment Register
For Period 6/1/2013 through 6/30/2013**

CHECKS UNDER \$25,000

<u>Vendor Name</u>	<u>Check/EFT Number</u>	<u>Payment Date</u>	<u>Inv Number</u>	<u>Invoice Description</u>	<u>Payment Amount</u>
Remit to: WILMINGTON, CA					
GENERAL SECURITY SERVICES, INC.	9632	06/17/2013	174060	SECURITY SVCS-LIBRARY 6/1/13	FYTD: \$53,863.33 \$813.02
			174042	SECURITY SVCS-TOWNGATE-6/1/13	
			173997	SECURITY SVCS-MVU 5/20-5/23/13	
			174059	SECURITY SVCS-CITY HALL 5/28-5/30/13	
			174097	SECURITY SVCS-CRC SPECIAL EVENTS 6/1/13	
Remit to: WILMINGTON, CA					
GENERAL SECURITY SERVICES, INC.	9666	06/24/2013	174147	SECURITY SVCS-LIBRARY 6/6/13 & 6/8/13	FYTD: \$53,863.33 \$552.24
			174145	SECURITY SVCS-CITY HALL 6/3-6/6/13	
Remit to: WILMINGTON, CA					
GEO PLASTICS, INC.	217549	06/10/2013	64844	DRAINER CONTAINERS 11 QT	FYTD: \$53,863.33 \$9,999.04
Remit to: LOS ANGELES, CA					
GIBBS, GIDEN, LOCHER, TURNER, SENET & WITTBRODT LLP	9478	06/03/2013	219346-005	LEGAL SERVICES - CITYWIDE SIDEWALKS (GOLDEN STATE CONSTRUCTORS)	FYTD: \$14,995.83 \$1,535.76
			219816-001	LEGAL SERVICES-GENERAL	
Remit to: LOS ANGELES, CA					
GIBBS, GIDEN, LOCHER, TURNER, SENET & WITTBRODT LLP	9667	06/24/2013	219816-005	LEGAL SERVICES - SR-60/NASON	FYTD: \$245,815.09 \$3,550.69
			219816-002	LEGAL SERVICES - SUNNYMEAD (EXCEL)	
Remit to: LOS ANGELES, CA					
					FYTD: \$245,815.09



**City of Moreno Valley
Payment Register
For Period 6/1/2013 through 6/30/2013**

CHECKS UNDER \$25,000

<u>Vendor Name</u>	<u>Check/EFT Number</u>	<u>Payment Date</u>	<u>Inv Number</u>	<u>Invoice Description</u>	<u>Payment Amount</u>
GLOBAL POWER GROUP, INC.	9583	06/10/2013	28941	CONSTRUCTION CONTRACT - EOC GENERATOR	\$14,434.03
Remit to: LAKESIDE, CA					
GLOBALSTAR USA, LLC	217703	06/24/2013	100000004038454	MOBILE SATELLITE TELEPHONE SERVICE FOR PD MCC	\$653.75
Remit to: LOS ANGELES, CA					
GONZALES, DOMILENA R.	9502	06/03/2013	130601	RETIREE MED MAY '13, PD JUNE '13	\$318.73
Remit to: MORENO VALLEY, CA					
GRAVES & KING, LLP	217550	06/10/2013	1304-0009442	LEGAL SERVICES-MV1261	\$7,529.23
			1304-0009459	LEGAL SERVICES-MV1329	
Remit to: RIVERSIDE, CA					
GRESHAM SAVAGE NOLAN & TILDEN	217551	06/10/2013	264791	LEGAL SERVICES-MAR13	\$4,417.53
			266197	LEGAL SERVICES-APR13	
Remit to: SAN BERNARDINO, CA					
GRIFFIN, MARLENE C	9503	06/03/2013	130601	RETIREE MED JUNE '13	\$255.43
Remit to: GREEN VALLEY, AZ					
GRUBE, PATTY	217515	06/03/2013	4/24/13 MILEAGE	MILEAGE REIMBURSEMENT - NUTRITION EDUCATION PARTNERSHIP FORUM	\$33.90
Remit to: MORENO VALLEY, CA					
GRUBER POWER SERVICES	217607	06/10/2013	139804	UPS POWER SYSTEM-ANNUAL MAINTENANCE	\$5,474.00
Remit to: PHOENIX, AZ					



**City of Moreno Valley
Payment Register
For Period 6/1/2013 through 6/30/2013**

CHECKS UNDER \$25,000

<u>Vendor Name</u>	<u>Check/EFT Number</u>	<u>Payment Date</u>	<u>Inv Number</u>	<u>Invoice Description</u>	<u>Payment Amount</u>
GUILLAN, REBECCA S.	9504	06/03/2013	130601	RETIREE MED MAY '13, PD JUNE '13	\$297.39
Remit to: ADVANCE, NC					
GUTIERREZ, ROBERT	9505	06/03/2013	130601	RETIREE MED JUNE '13	\$318.73
Remit to: LA VERNE, CA					
HAMLIN, WILLIAM R.	9506	06/03/2013	130601	RETIREE MED JUNE '13	\$318.73
Remit to: BEAUMONT, CA					
HANES, MARTIN D.	9507	06/03/2013	130601	RETIREE MED JUNE '13	\$318.73
Remit to: MORENO VALLEY, CA					
HARDING, JOHN	217495	06/03/2013	130601	RETIREE MED JUNE '13	\$318.73
Remit to: BANNING, CA					
HATFIELD, CHARLES	9508	06/03/2013	130601	RETIREE MED JUNE '13	\$318.73
Remit to: LAS VEGAS, NV					
HDL COREN & CONE	217465	06/03/2013	0019214-IN	CONTRACT SVCS-PROPERTY TAX - APR-JUN13	\$4,387.50
Remit to: DIAMOND BAR, CA					
HDL COREN & CONE	217704	06/24/2013	0018744-IN	CONTRACT SVCS-PROPERTY TAX - OCT-DEC 2012	\$8,775.00
Remit to: DIAMOND BAR, CA					
HDR ENGINEERING, INC.	217552	06/10/2013	72311-B	CONSULTING SERVICES, ENGINEERING - CACTUS/NASON	\$3,944.75
Remit to: DIAMOND BAR, CA					

Item No. A.7



**City of Moreno Valley
Payment Register
For Period 6/1/2013 through 6/30/2013**

CHECKS UNDER \$25,000

<u>Vendor Name</u>	<u>Check/EFT Number</u>	<u>Payment Date</u>	<u>Inv Number</u>	<u>Invoice Description</u>	<u>Payment Amount</u>
Remit to: IRVINE, CA				<u>FYTD:</u>	\$10,723.34
HDR ENGINEERING, INC.	217616	06/17/2013	79424-B	CONSULTING SERVICES, ENGINEERING - CACTUS/NASON	\$2,865.28
Remit to: IRVINE, CA				<u>FYTD:</u>	\$10,723.34
HEFFLEY, ROSS W.	9509	06/03/2013	130601	RETIREE MED JUNE '13	\$318.73
Remit to: HEMET, CA				<u>FYTD:</u>	\$3,506.03
HERRICK, ROBERT D.	217497	06/03/2013	130601	RETIREE MED JUNE '13	\$318.73
Remit to: MORENO VALLEY, CA				<u>FYTD:</u>	\$3,506.03
HIGHLAND FAIRVIEW	217530	06/03/2013	T&M PA07-0091	REFUND-TIME & MATERIALS EXCESS DEPOSIT-CLOSED ACCT	\$950.68
Remit to: MORENO VALLEY, CA				<u>FYTD:</u>	\$950.68
HILLTOP GEOTECHNICAL, INC.	9633	06/17/2013	14047	PHASE I ENVIRONMENTAL ASSESSMENT	\$2,700.00
Remit to: SAN BERNARDINO, CA				<u>FYTD:</u>	\$18,588.50
HOGARD, JOHN T.	9510	06/03/2013	130601	RETIREE MED JAN-MAR '13, PD JUNE '13	\$300.00
Remit to: CORONA, CA				<u>FYTD:</u>	\$1,600.00
HOLLY LOGUE	217662	06/17/2013	R13-060652	AS REFUND-RABIES & S/N DEPOSITS	\$95.00
Remit to: LOS ANGELES, CA				<u>FYTD:</u>	\$95.00
HOLT, ANITRA N	217498	06/03/2013	130601	RETIREE MED JUNE '13	\$318.73
Remit to: CLERMONT, FL				<u>FYTD:</u>	\$1,593.65
HONDA YAMAHA OF REDLANDS	9584	06/10/2013	18588	MAINT & REPAIRS-LABOR & PARTS-TRAFFIC MOTORCYCLES	\$715.48



**City of Moreno Valley
Payment Register
For Period 6/1/2013 through 6/30/2013**

CHECKS UNDER \$25,000

<u>Vendor Name</u>	<u>Check/EFT Number</u>	<u>Payment Date</u>	<u>Inv Number</u>	<u>Invoice Description</u>	<u>Payment Amount</u>
Remit to: REDLANDS, CA				<u>FYTD:</u>	\$25,074.11
HOUSER, EDITH E.	217499	06/03/2013	130601	RETIREE MED JUNE '13	\$318.73
Remit to: MORENO VALLEY, CA				<u>FYTD:</u>	\$3,506.03
HUNTER ESQUIBEL	217654	06/17/2013	1036169	REFUND ELECTRIC GUITAR AND BASS	\$52.00
Remit to: MORENO VALLEY, CA				<u>FYTD:</u>	\$52.00
ICMA RETIREMENT CORP	9612	06/14/2013	2013-00000115	8030 - DEF COMP 457 - ICMA	\$15,791.11
Remit to: BALTIMORE, MD				<u>FYTD:</u>	\$263,127.46
ICMA RETIREMENT CORP	9698	06/28/2013	2013-00000131	8030 - DEF COMP 457 - ICMA	\$15,791.11
Remit to: BALTIMORE, MD				<u>FYTD:</u>	\$263,127.46
ICR DOORS	9585	06/10/2013	648	REPAIRS TO ANNEX 1 ROLL UP DOORS	\$1,787.00
Remit to: UPLAND, CA				<u>FYTD:</u>	\$8,828.97
IES COMMERCIAL, INC	9668	06/24/2013	99099	ANNEX 1 MVU-LOBBY DOOR ELECTRIFIED HARDWARE	\$2,679.84
Remit to: TEMPE, AZ				<u>FYTD:</u>	\$22,949.06
IL SORRENTO MOBILE PARK	217553	06/10/2013	APRIL 2013	REFUND-UUT FOR EXEMPT RESIDENTS	\$79.65
Remit to: MORENO VALLEY, CA				<u>FYTD:</u>	\$1,232.36
INLAND EMPIRE MAGAZINE	217554	06/10/2013	INV33992	AD PLACEMENT FOR BALLROOM AT CRC-JUN13 ISSUE	\$895.00
Remit to: RIVERSIDE, CA				<u>FYTD:</u>	\$5,385.00
INSIDE PLANTS, INC.	217617	06/17/2013	47142	INDOOR PLANT MAINT-CRC-JUN13	\$320.00

Item No. A.7



**City of Moreno Valley
Payment Register
For Period 6/1/2013 through 6/30/2013**

CHECKS UNDER \$25,000

<u>Vendor Name</u>	<u>Check/EFT Number</u>	<u>Payment Date</u>	<u>Inv Number</u>	<u>Invoice Description</u>	<u>Payment Amount</u>
Remit to: CORONA, CA					<u>FYTD:</u> \$3,840.00
ISG INFRASYS	217705	06/24/2013	38419	REPAIR THERMAL IMAGING CAMERA-FS#91	\$537.59
Remit to: LAWRENCEVILLE, GA					<u>FYTD:</u> \$1,695.36
J D H CONTRACTING	9479	06/03/2013	052913-01	DOOR INSTALLATION AT CITY HALL	\$3,362.00
Remit to: RIVERSIDE, CA					<u>FYTD:</u> \$143,761.90
J D H CONTRACTING	9586	06/10/2013	042913-02	INSTALL ADA DRINKING FOUNTAIN AT WESTON PARK	\$6,967.00
			042913-01	INSTALL DRINKING FOUNTAIN AT JFK PARK	
			053113-01	CONSTRUCTION REPAIRS-WESTON PARK	
Remit to: RIVERSIDE, CA					<u>FYTD:</u> \$143,761.90
J D H CONTRACTING	9669	06/24/2013	060513-01	CONSTRUCTION REPAIRS-WESTON PARK	\$2,110.00
			051013-02	INDEPENDANT CONTRACTOR - MORRISON PARK FS	
Remit to: RIVERSIDE, CA					<u>FYTD:</u> \$143,761.90
JACK HENRY & ASSOCIATES	217618	06/17/2013	1438257	PROFIT STARS MONTHLY SERVICE FEES	\$306.15
Remit to: MONETT, MO					<u>FYTD:</u> \$3,364.45
JACQUELINE ALLEE	217673	06/17/2013	MV2120106023	REFUND-CITATION OVERPAYMENT	\$288.00
Remit to: RIVERSIDE, CA					<u>FYTD:</u> \$288.00
JESSICA GARRARD	217590	06/10/2013	R13-061890	AS REFUND-TRAP	\$50.00
Remit to: MORENO VALLEY, CA					<u>FYTD:</u> \$50.00
JOEY HARDIE	217681	06/17/2013	MV3120619002	REFUND-CITATION OVERPAYMENT	\$115.00



**City of Moreno Valley
Payment Register
For Period 6/1/2013 through 6/30/2013**

CHECKS UNDER \$25,000

<u>Vendor Name</u>	<u>Check/EFT Number</u>	<u>Payment Date</u>	<u>Inv Number</u>	<u>Invoice Description</u>	<u>Payment Amount</u>
Remit to: MORENO VALLEY, CA					<u>FYTD:</u> \$115.00
JOHN W. STRICKLER	9550	06/03/2013	130601	RETIREE MED JUNE '13	\$318.73
Remit to: SAN BERNARDINO, CA					<u>FYTD:</u> \$3,187.30
JOHNNY TAN	217671	06/17/2013	R13-062801	AS REFUND-TRAP DEPOSIT	\$50.00
Remit to: MORENO VALLEY, CA					<u>FYTD:</u> \$50.00
JONES III, JOSEPH	217516	06/03/2013	3/14/13-4/30/13	MILEAGE REIMBURSEMENT	\$199.45
			1/2/13-3/12/13	MILEAGE REIMBURSEMENT	
Remit to: FONTANA, CA					<u>FYTD:</u> \$448.10
JONES, SUSAN	9511	06/03/2013	130601	RETIREE MED JUNE '13	\$318.73
Remit to: MORENO VALLEY, CA					<u>FYTD:</u> \$3,506.03
JORRY KEITH	217517	06/03/2013	MAY-2013	INSTRUCTOR SVCS-COMIC BOOK CREATION CLASS	\$144.00
Remit to: FONTANA, CA					<u>FYTD:</u> \$1,303.20
JORRY KEITH	217739	06/24/2013	JUN-2013	INSTRUCTOR SVCS-COMIC BOOK CREATION CLASS	\$175.20
Remit to: FONTANA, CA					<u>FYTD:</u> \$1,303.20
JOSE RODRIGUEZ	217527	06/03/2013	ACCT 7008963-03	SOLAR INCENTIVE REBATE	\$9,954.00
Remit to: MORENO VALLEY, CA					<u>FYTD:</u> \$9,954.00
JOYCE NELSON	217595	06/10/2013	R13-062474	AS REFUND-SPAY/NEUTER DEPOSIT	\$75.00
Remit to: YORBA LINDA, CA					<u>FYTD:</u> \$75.00



City of Moreno Valley
Payment Register
 For Period 6/1/2013 through 6/30/2013

CHECKS UNDER \$25,000

<u>Vendor Name</u>	<u>Check/EFT Number</u>	<u>Payment Date</u>	<u>Inv Number</u>	<u>Invoice Description</u>	<u>Payment Amount</u>
JUDY NGA KWAN	217661	06/17/2013	RCT#0329424	REFUND-CANCELLED CERT CLASS	\$15.00
Remit to: CORONA, CA					
KATRINA DENSON	217677	06/17/2013	MV2120508024	REFUND-CITATION OVERPAYMENT	\$107.00
Remit to: MORENO VALLEY, CA					
KELLY BRINTLE	217675	06/17/2013	MV2111223046	REFUND-CITATION OVERPAYMENT	\$115.00
Remit to: SHAFTER, CA					
KELLY ROSE	217597	06/10/2013	R13-062065	AS REFUND-ADOPT,VACS,CHIP,LICENSE	\$82.00
Remit to: MORENO VALLEY, CA					
KEN'S TREE SERVICE	217591	06/10/2013	BL#036661-YR2013	REFUND OF OVERPAYMENT FOR B/L#036661	\$72.00
Remit to: LAKEVIEW, CA					
KEPLER, JANELLE	9670	06/24/2013	JUN-2013	INSTRUCTOR SVCS-CHEERLEADING CLASS	\$512.40
Remit to: RIVERSIDE, CA					
KING, PATRICIA A.	217500	06/03/2013	130601	RETIREE MED JUNE '13	\$210.74
Remit to: LAS VEGAS, NV					
KOLB, CHARLES E.	9512	06/03/2013	130601	RETIREE MED JUNE '13	\$318.73
Remit to: MORENO VALLEY, CA					
KOLLAR, KYLE	9513	06/03/2013	130601	RETIREE MED JUNE '13	\$318.73
Remit to: MORENO VALLEY, CA					



**City of Moreno Valley
Payment Register
For Period 6/1/2013 through 6/30/2013**

CHECKS UNDER \$25,000

<u>Vendor Name</u>	<u>Check/EFT Number</u>	<u>Payment Date</u>	<u>Inv Number</u>	<u>Invoice Description</u>	<u>Payment Amount</u>
KUPSAK, STEVE	9514	06/03/2013	130601	RETIREE MED APR '13, PD JUNE '13	\$318.73
Remit to: CEDAR GLEN, CA					
KYLE, GARY M.	9515	06/03/2013	130601	RETIREE MED JUNE '13	\$318.73
Remit to: PRESCOTT VALLEY, AZ					
KYONJO GANIBE	217655	06/17/2013	1036072	REFUND FOR ENGLISH AS A SECOND LANGUAGE	\$112.00
Remit to: MORENO VALLEY, CA					
LA FOLLETTE, JOHNSON, DE HAAS, FESLER & AMES	217466	06/03/2013	273044	LEGAL SERVICES-RE: M. ESCOBAR	\$126.00
Remit to: LOS ANGELES, CA					
LAFATA, JOSEPHINE	9516	06/03/2013	130601	RETIREE MED JUNE '13	\$318.73
Remit to: MORENO VALLEY, CA					
LATITUDE GEOGRAPHICS	217706	06/24/2013	201300500	GIS SOFTWARE & SERVICES-M5 (FINAL)	\$19,863.97
Remit to: VICTORIA, BC					
LAWYERS TITLE INC	217619	06/17/2013	00647419	PRELIMINARY REPORT PACKAGE - NORTHEAST FS	\$550.00
Remit to: NEWPORT BEACH, CA					
LEIVAS, INC. DBA: LEIVAS LIGHTING	9635	06/17/2013	236158	LANDSCAPE LIGHTING INSPECTION-ZONE E7-MAY13	\$25.00
Remit to: RIVERSIDE, CA					
LEWIS BRISBOIS BISGAARD & SMITH LLP	217620	06/17/2013	1183478	LEGAL SERVICES-CASE#RIC533180	\$10,285.94
Remit to: RIVERSIDE, CA					



**City of Moreno Valley
Payment Register
For Period 6/1/2013 through 6/30/2013**

CHECKS UNDER \$25,000

<u>Vendor Name</u>	<u>Check/EFT Number</u>	<u>Payment Date</u>	<u>Inv Number</u>	<u>Invoice Description</u>	<u>Payment Amount</u>
Remit to: LOS ANGELES, CA				<u>FYTD:</u>	\$18,294.73
LEWIS, CAROLYN S.	9517	06/03/2013	130601	RETIREE MED JUNE '13	\$318.73
Remit to: MIDLAND, TX				<u>FYTD:</u>	\$3,506.03
LEXISNEXIS PRACTICE MGMT.	9636	06/17/2013	1305081469	ONLINE RESEARCH TOOLS-MAY13	\$1,180.00
Remit to: LOS ANGELES, CA				<u>FYTD:</u>	\$14,760.00
LIEBERT, CASSIDY, WHITMORE	217621	06/17/2013	164584	LEGAL SERVICES/MO140-00001	\$3,575.00
	164585			LEGAL SERVICES/MO140-00011	
	05222013			WORKSHOP REGISTRATION-4/11/13	
Remit to: LOS ANGELES, CA				<u>FYTD:</u>	\$30,514.82
LINDA SCHECHY	217528	06/03/2013	ACCT 7013550-02	SOLAR INCENTIVE REBATE	\$14,000.00
Remit to: MORENO VALLEY, CA				<u>FYTD:</u>	\$14,000.00
LINDO, HERMINA G.	9518	06/03/2013	130601	RETIREE MED APRIL '13 TRI&MED, PD JUNE '13	\$127.34
Remit to: TITUSVILLE, FL				<u>FYTD:</u>	\$1,890.56
LOGAN, CHARLES	9519	06/03/2013	130601	RETIREE MED JUNE '13	\$318.73
Remit to: LAS VEGAS, NV				<u>FYTD:</u>	\$3,506.03
LONGDYKE, DENNIS	9520	06/03/2013	130601	RETIREE MED JUNE '13	\$318.73
Remit to: BEAUMONT, CA				<u>FYTD:</u>	\$3,506.03
LORENA CASAS	217649	06/17/2013	1047604	REFUND AKAI KEMPO	\$47.00



**City of Moreno Valley
Payment Register
For Period 6/1/2013 through 6/30/2013**

CHECKS UNDER \$25,000

<u>Vendor Name</u>	<u>Check/EFT Number</u>	<u>Payment Date</u>	<u>Inv Number</u>	<u>Invoice Description</u>	<u>Payment Amount</u>
Remit to: MORENO VALLEY, CA					<u>FYTD:</u> \$47.00
LORIE NATZIC	217664	06/17/2013	R13-058867	AS REFUND-S/N DEPOSIT	\$75.00
Remit to: MURRIETA, CA					<u>FYTD:</u> \$75.00
LOS ANGELES COUNTY AUDITOR CONTROLLER	217707	06/24/2013	13ME0332	GSR KITS ANALYZED	\$1,068.00
Remit to: LOS ANGELES, CA					<u>FYTD:</u> \$1,068.00
LUMLEY, ROBERT C.	9521	06/03/2013	130601	RETIREE MED JUNE '13	\$318.73
Remit to: MORENO VALLEY, CA					<u>FYTD:</u> \$3,506.03
MAGNUM BREEZE II, INC/WOODCREST VEH CTR	9671	06/24/2013	12882	INSTALLATION OF INSULATION IN SET SURVEILLANCE VEHICLE	\$2,895.72
Remit to: RIVERSIDE, CA					<u>FYTD:</u> \$2,895.72
MALCOLM SMITH MOTORCYCLES, INC.	9587	06/10/2013	100061659	MAINT & REPAIRS-LABOR & PARTS-TRAFFIC MOTORCYCLES	\$2,471.30
			100061654	MAINT & REPAIRS-LABOR & PARTS-TRAFFIC MOTORCYCLES	
Remit to: RIVERSIDE, CA					<u>FYTD:</u> \$40,348.45
MALCOLM SMITH MOTORCYCLES, INC.	9672	06/24/2013	100065569	MAINT & REPAIRS-LABOR & PARTS-TRAFFIC MOTORCYCLES	\$1,053.00
Remit to: RIVERSIDE, CA					<u>FYTD:</u> \$40,348.45
MARCH JOINT POWERS AUTHORITY	217555	06/10/2013	0027758	GAS CHARGES-BLDG 938-APR13	\$5.37
			0027754	GAS CHARGES-BLDG 823-APR13	



**City of Moreno Valley
Payment Register
For Period 6/1/2013 through 6/30/2013**

CHECKS UNDER \$25,000

<u>Vendor Name</u>	<u>Check/EFT Number</u>	<u>Payment Date</u>	<u>Inv Number</u>	<u>Invoice Description</u>	<u>Payment Amount</u>
Remit to: RIVERSIDE, CA				<u>FYTD:</u>	\$75.99
MARGARET BRIGGS	217585	06/10/2013	1045055	REFUNDS FOR RENTALS	\$781.50
Remit to: MORENO VALLEY, CA				<u>FYTD:</u>	\$781.50
MARICRUZ BERNABE	217674	06/17/2013	MV3120810003	REFUND-CITATION OVERPAYMENT	\$65.00
Remit to: MORENO VALLEY, CA				<u>FYTD:</u>	\$65.00
MARINA LANDSCAPE, INC	9673	06/24/2013	8216051300	LANDSCAPE MAINT-ZONE E-1/E-1A-MAY13	\$5,733.34
Remit to: ANAHEIM, CA				<u>FYTD:</u>	\$92,398.64
MARIO MORENO	217593	06/10/2013	R13-062227	AS REFUND-ADOPT,VACCINES,MICROCHIP	\$67.00
Remit to: MENIFEE, CA				<u>FYTD:</u>	\$67.00
MARTIN & CHAPMAN CO.	217622	06/17/2013	2013073	CONSULTING FEES INCLUDING ELECTION MANUAL	\$512.05
Remit to: ANAHEIM, CA				<u>FYTD:</u>	\$512.05
MATHIS, NOLAN	9522	06/03/2013	130601	RETIREE MED APR '13, PD JUNE '13	\$298.20
Remit to: JACKSON, KY				<u>FYTD:</u>	\$3,151.40
MATT/LISSETTE TERRILL	217598	06/10/2013	R13-060183	AS REFUND-SPAY/NEUTER DEPOSIT	\$75.00
Remit to: MORENO VALLEY, CA				<u>FYTD:</u>	\$75.00
MATTHEW HINOTE	217525	06/03/2013	7011276-04	SOLAR INCENTIVE REBATE	\$14,000.00
Remit to: MORENO VALLEY, CA				<u>FYTD:</u>	\$14,000.00
MAXINOSKI, SUE A.	9523	06/03/2013	130601	RETIREE MED JUNE '13	\$318.73



City of Moreno Valley
Payment Register
 For Period 6/1/2013 through 6/30/2013

CHECKS UNDER \$25,000

<u>Vendor Name</u>	<u>Check/EFT Number</u>	<u>Payment Date</u>	<u>Inv Number</u>	<u>Invoice Description</u>	<u>Payment Amount</u>
Remit to: AVINGER, TX					<u>FYTD:</u> \$3,506.03
MEEKS, DANIEL	9674	06/24/2013	060613	SPORTS OFFICIATING SERVICES	\$120.00
			060213	SPORTS OFFICIATING SERVICES	
Remit to: PERRIS, CA					<u>FYTD:</u> \$1,540.00
MERCHANTS LANDSCAPE SERVICES INC	9675	06/24/2013	40294	LANDSCAPE LIGHTING MAINT-ZONE E3-ADDL WORK-MAY13	\$19,208.76
			40117	LANDSCAPE MAINT-ZONE E8, E14, E15 & E12-MAY13	
			40293	LANDSCAPE MAINT-ZONE E12-ADDL WORK-MAY13	
			40118	LANDSCAPE LIGHTING MAINT-ZONE E3 & E3A-MAY13	
Remit to: Santa Ana, CA					<u>FYTD:</u> \$232,852.89
MESSIN, LOUIS	9524	06/03/2013	130601	RETIREE MED JUNE '13	\$318.73
Remit to: BULLHEAD CITY, AZ					<u>FYTD:</u> \$3,506.03
METZ, RANDALL	217740	06/24/2013	SPRING 2013	TUITION REIMBURSEMENT	\$1,500.00
Remit to: ARCADIA, CA					<u>FYTD:</u> \$2,111.50
MILES, ROBERT	9525	06/03/2013	130601	RETIREE MED JUNE '13	\$146.32
Remit to: MORENO VALLEY, CA					<u>FYTD:</u> \$2,007.87
MINARD, MARK E.	9526	06/03/2013	130601	RETIREE MED JUNE '13	\$318.73
Remit to: REDLANDS, CA					<u>FYTD:</u> \$3,506.03
MISTRETTA, ARTHUR	217623	06/17/2013	041813	SPORTS OFFICIATING SERVICES-SOFTBALL	\$60.00



City of Moreno Valley
Payment Register
 For Period 6/1/2013 through 6/30/2013

CHECKS UNDER \$25,000

<u>Vendor Name</u>	<u>Check/EFT Number</u>	<u>Payment Date</u>	<u>Inv Number</u>	<u>Invoice Description</u>	<u>Payment Amount</u>
Remit to: MORENO VALLEY, CA					<u>FYTD:</u> \$960.00
MOLLICA, MIKE	9527	06/03/2013	130601	RETIREE MED JUNE '13	\$401.42
Remit to: DUNNELLO, FL					<u>FYTD:</u> \$4,415.62
MONTGOMERY PLUMBING INC	217467	06/03/2013	052113	PLUMBING SVCS-ANIMAL SHELTER	\$852.50
			052013	REPLACED TWO FAUCETS-SENIOR CTR	
Remit to: MORENO VALLEY, CA					<u>FYTD:</u> \$16,551.25
MONTGOMERY PLUMBING INC	217556	06/10/2013	052213	PLUMBING SVCS-ANIMAL SHELTER	\$375.00
Remit to: MORENO VALLEY, CA					<u>FYTD:</u> \$16,551.25
MORA, PATRICIA A.	9528	06/03/2013	130601	RETIREE MED JUNE '13	\$318.73
Remit to: MORENO VALLEY, CA					<u>FYTD:</u> \$3,506.03
MORENO VALLEY CHAMBER OF COMMERCE	217518	06/03/2013	3731	WAKE-UP MEETING ATTENDANCE-5/22/13	\$45.00
Remit to: MORENO VALLEY, CA					<u>FYTD:</u> \$20,615.00
MORENO VALLEY CITY EMPLOYEES ASSOC.	9618	06/14/2013	2013-00000123	8710 - MVCEA EMPLOYEE DUES*	\$1,369.00
Remit to: MORENO VALLEY, CA					<u>FYTD:</u> \$36,185.00
MORENO VALLEY CITY EMPLOYEES ASSOC.	9699	06/28/2013	2013-00000132	8710 - MVCEA EMPLOYEE DUES	\$1,369.00
Remit to: MORENO VALLEY, CA					<u>FYTD:</u> \$36,185.00
MORENO VALLEY GATEWAY, LLC	9638	06/17/2013	2177	LEASE-SUITES 5-9/ESA ANNEX-JUL13	\$17,142.59



**City of Moreno Valley
Payment Register
For Period 6/1/2013 through 6/30/2013**

CHECKS UNDER \$25,000

<u>Vendor Name</u>	<u>Check/EFT Number</u>	<u>Payment Date</u>	<u>Inv Number</u>	<u>Invoice Description</u>	<u>Payment Amount</u>
MORENO VALLEY GATEWAY, LLC	9638	06/17/2013	2175	LEASE-FACILITIES ANNEX-JUL13	\$17,142.59
			2176	LEASE-T/S ANNEX-JUL13	
Remit to: SAN JUAN CAPISTRANO, CA					
MORGAN, LISA A.	9529	06/03/2013	130601	RETIREE MED JUNE '13	\$318.73
Remit to: MENTONE, CA					
MOTOPOST USA	217708	06/24/2013	140424	NEW MOTOR UNIFORMS-PD	\$7,877.52
Remit to: SAN MARCOS, CA					
MTGL, INC	9676	06/24/2013	0047042	CONSULTING SERVICES, GEOTECHNICAL - CITYWIDE PAVEMENT	\$4,305.00
			0045054	CONSULTING SERVICES, GEOTECHNICAL - CITYWIDE PAVEMENT	
			0045055	CONSULTING SERVICES, GEOTECHNICAL - ALESSANDRO BLVD. IMP	
Remit to: ANAHEIM, CA					
MVBFA	217594	06/10/2013	MVBFA 1038029	REFUNDS FOR RENTALS	\$500.00
Remit to: MORENO VALLEY, CA					
NATIONWIDE RETIREMENT SOLUTIONS CP	9613	06/14/2013	2013-00000117	8020 - DEF COMP PST - NATIONWIDE	\$2,825.88
Remit to: COLUMBUS, OH					
NATIONWIDE RETIREMENT SOLUTIONS CP	9702	06/28/2013	2013-00000135	8020 - DEF COMP PST - NATIONWIDE	\$2,576.96
Remit to: COLUMBUS, OH					
NAVARRETTE, RALPH	9530	06/03/2013	130601	RETIREE MED JUNE '13	\$146.32
FYTD: \$205,711.08					
FYTD: \$3,506.03					
FYTD: \$11,529.68					
FYTD: \$21,920.00					
FYTD: \$500.00					
FYTD: \$737,316.85					



**City of Moreno Valley
Payment Register
For Period 6/1/2013 through 6/30/2013**

CHECKS UNDER \$25,000

<u>Vendor Name</u>	<u>Check/EFT Number</u>	<u>Payment Date</u>	<u>Inv Number</u>	<u>Invoice Description</u>	<u>Payment Amount</u>
Remit to: RANCHO CUCAMONGA, CA					<u>FYTD:</u> \$2,007.87
NAVCO NETWORKS & SECURITY	9588	06/10/2013	340504	REPAIR OF DVR LOCATED IN PATROL SGT. OFFICE	\$578.05
Remit to: ANAHEIM, CA					<u>FYTD:</u> \$2,279.89
NELSON, ROBERT	9531	06/03/2013	130601	RETIREE MED JUNE '13	\$255.43
Remit to: ONTARIO, CA					<u>FYTD:</u> \$3,134.73
NELSON, RUTH L.	9532	06/03/2013	130601	RETIREE MED JUNE '13	\$173.37
Remit to: PERRIS, CA					<u>FYTD:</u> \$1,869.27
NEUSTAEDTER, CRAIG S	217501	06/03/2013	130601	RETIREE MED JUNE '13	\$318.73
Remit to: IRVINE, CA					<u>FYTD:</u> \$3,506.03
NEW WORLD SYSTEMS, CORP	9639	06/17/2013	027805	LOGOS SOFTWARE ESCROW ANNUAL FEE	\$1,102.00
Remit to: TROY, MI					<u>FYTD:</u> \$223,074.71
NEXUS IS, INC.	9640	06/17/2013	JC630051	CISCO 6500 48-PORT 10/100/1000 RJ45 MODULE	\$18,948.02
			JC629919	CISCO FIREWALL FOR PD SURVEILLANCE AND TMS	
Remit to: VALENCIA, CA					<u>FYTD:</u> \$116,750.54
NIEBURGER, JUDITH A.	217502	06/03/2013	130601	RETIREE MED JUNE '13	\$401.42
Remit to: MORENO VALLEY, CA					<u>FYTD:</u> \$4,415.62
NIELSEN LLC, CLARITAS	217557	06/10/2013	2090530	ANNUAL RENEWAL FOR SITEREPORTS.COM 5/20/13 - 5/19/14	\$3,090.00
Remit to: CHARLOTTE, NC					<u>FYTD:</u> \$3,090.00



**City of Moreno Valley
Payment Register
For Period 6/1/2013 through 6/30/2013**

CHECKS UNDER \$25,000

<u>Vendor Name</u>	<u>Check/EFT Number</u>	<u>Payment Date</u>	<u>Inv Number</u>	<u>Invoice Description</u>	<u>Payment Amount</u>
NINYO & MOORE GEOTECHNICAL	9677	06/24/2013	173138	CONSULTING SERVICES, GEOTECHNICAL - SR-60/MB PH I	\$14,968.32
			172245	CONSULTING SERVICES, GEOTECHNICAL - SIP KENTLAND, WILSON, KINNY	
Remit to: SAN DIEGO, CA					<u>FYTD:</u> \$122,870.57
NUBIA FLORES	217524	06/03/2013	1043626	REFUND FOR TOWNGATE DEPOSIT	\$200.00
Remit to: MORENO VALLEY, CA					<u>FYTD:</u> \$200.00
OLIVIER PRUD'HOMME	217644	06/17/2013	306 a	SOULSOMATIK BAND-6/21/13 CONCERT AT TOWNGATE PARK	\$1,200.00
Remit to: STUDIO CITY, CA					<u>FYTD:</u> \$1,500.00
OVERLAND PACIFIC & CUTLER, INC.	9589	06/10/2013	1303239	RELOCATION SERVICES-MYERS AVE. PROJECT	\$520.00
Remit to: LONG BEACH, CA					<u>FYTD:</u> \$57,235.75
PACIFIC SAFETY CENTER	9641	06/17/2013	431	ANNUAL MEMBERSHIP RENEWAL-SAFETY TRAINING PROGRAM	\$3,670.00
			69709	HAZWOPER 8 HOUR & TRAFFIC CTRL & FLAGGER SAFETY CLASSES-APRIL'13	
Remit to: SAN DIEGO, CA					<u>FYTD:</u> \$5,620.00
PAINTING BY ZEB BODE	9480	06/03/2013	132305	CITY HALL 2ND FLOOR RENOVATION WORK-PAINT, PATCH, SAND WALLS	\$8,890.50
			132804 a	PAINTING OF 2 ONE THOUSAND GAL. ABOVE GROUND FUEL STORAGE TANKS	
Remit to: NORCO, CA					<u>FYTD:</u> \$56,003.50
PAINTING BY ZEB BODE	9590	06/10/2013	132405	TOUCH UP PAINTING AT TOWNGATE COMMUNITY CENTER	\$650.00
Remit to: NORCO, CA					<u>FYTD:</u> \$56,003.50



**City of Moreno Valley
Payment Register
For Period 6/1/2013 through 6/30/2013**

CHECKS UNDER \$25,000

<u>Vendor Name</u>	<u>Check/EFT Number</u>	<u>Payment Date</u>	<u>Inv Number</u>	<u>Invoice Description</u>	<u>Payment Amount</u>
PAINTING BY ZEB BODE	9642	06/17/2013	130611	PAINTING AT CITY HALL-ACCENT COLOR IN ARCH WAYS	\$800.00
Remit to: NORCO, CA <u>FYTD:</u> \$56,003.50					
PARSONS TRANSPORTATION GROUP, INC.	9693	06/27/2013	1306A245	ENGINEERING SERVICIES - SR-60/NASON OC	\$375.55
Remit to: IRVINE, CA <u>FYTD:</u> \$1,198,847.37					
PATTERSON, ALFREY	217503	06/03/2013	130601	RETIREE MED JUNE '13	\$146.32
Remit to: MORENO VALLEY, CA <u>FYTD:</u> \$2,007.87					
PEDLEY SQUARE VETERINARY CLINIC	9591	06/10/2013	APR-2013	VETERINARY SERVICES FOR MV ANIMAL SHELTER	\$8,898.00
Remit to: RIVERSIDE, CA <u>FYTD:</u> \$76,176.25					
PERRY, NORMA	9533	06/03/2013	130601	RETIREE MED JUNE '13	\$318.73
Remit to: LOCKEFORD, CA <u>FYTD:</u> \$3,506.03					
PERS LONG TERM CARE PROGRAM	217468	06/03/2013	2013-00000092	4720 - PERS LONG TERM CARE	\$458.63
Remit to: PASADENA, CA <u>FYTD:</u> \$11,465.75					
PERS LONG TERM CARE PROGRAM	217625	06/17/2013	2013-00000113	4720 - PERS LONG TERM CARE	\$458.63
Remit to: PASADENA, CA <u>FYTD:</u> \$11,465.75					
PERS RETIREMENT	9565	06/06/2013	P130510a	PERS RETIREMENT - CLASSIC	\$9,342.18
Remit to: SACRAMENTO, CA <u>FYTD:</u> \$6,282,891.10					
PERS RETIREMENT	9566	06/06/2013	P130510b	PERS RETIREMENT - PEPPRA	\$2,481.21



**City of Moreno Valley
Payment Register
For Period 6/1/2013 through 6/30/2013**

CHECKS UNDER \$25,000

<u>Vendor Name</u>	<u>Check/EFT Number</u>	<u>Payment Date</u>	<u>Inv Number</u>	<u>Invoice Description</u>	<u>Payment Amount</u>
Remit to: SACRAMENTO, CA					<u>FYTD:</u> \$6,282,891.10
PERS RETIREMENT	9696	06/21/2013	P130524a	PERS RETIREMENT - CLASSIC	\$8,086.47
Remit to: SACRAMENTO, CA					<u>FYTD:</u> \$6,282,891.10
PERS RETIREMENT	9697	06/21/2013	P130524b	PERS RETIREMENT - PEPPRA	\$3,537.01
Remit to: SACRAMENTO, CA					<u>FYTD:</u> \$6,282,891.10
PERS RETIREMENT	9855	06/30/2013	P130607a	PERS RETIREMENT - CLASSIC	\$7,761.22
Remit to: SACRAMENTO, CA					<u>FYTD:</u> \$6,282,891.10
PERS RETIREMENT	9856	06/30/2013	P130607b	PERS RETIREMENT - PEPPRA	\$3,545.98
Remit to: SACRAMENTO, CA					<u>FYTD:</u> \$6,282,891.10
PLUMMER, TED	217742	06/24/2013	101	SOUND SYSTEMS FOR JULY 4, 2013 PARADE	\$650.00
Remit to: MORENO VALLEY, CA					<u>FYTD:</u> \$650.00
POUNDS, NANCY	9534	06/03/2013	130601	RETIREE MED MAY '13, PD JUNE '13	\$318.73
Remit to: BOISE, ID					<u>FYTD:</u> \$3,187.30
POWELL CONSTRUCTORS, INC.	9621	06/10/2013	W130603	RETENTION RELEASE PER ESCROW AGREEMENT	\$22,773.70
Remit to: FONTANA, CA					<u>FYTD:</u> \$4,212,952.02
PRICE, GEORGE E.	9535	06/03/2013	130601	RETIREE MED JUNE '13	\$318.73
Remit to: MORENO VALLEY, CA					<u>FYTD:</u> \$3,506.03
PROQUEST CSA	217470	06/03/2013	US10003693	RENEWAL OF SIRS DATABASES FOR 2013 FOR THE LIBRARY	\$2,505.00

Item No. A.7



**City of Moreno Valley
Payment Register
For Period 6/1/2013 through 6/30/2013**

CHECKS UNDER \$25,000

<u>Vendor Name</u>	<u>Check/EFT Number</u>	<u>Payment Date</u>	<u>Inv Number</u>	<u>Invoice Description</u>	<u>Payment Amount</u>
Remit to: CHIGAGO, IL				<u>FYTD:</u>	\$2,505.00
PSOMAS	217710	06/24/2013	89197	CONSULTING SERVICES, SURVEY - SR-60/NASON OC	\$24,152.36
Remit to: SANTA ANA, CA				<u>FYTD:</u>	\$137,850.77
PTM GENERAL ENGINEERING SERVICES, INC.	217711	06/24/2013	043013121	CONSTRUCTION CONTRACT RELEASE OF RETENTION	\$8,903.82
Remit to: RIVERSIDE, CA				<u>FYTD:</u>	\$178,076.33
PULLIAM, TRENT D.	9536	06/03/2013	130601	RETIREE MED JUNE '13	\$318.73
Remit to: MISSION VIEJO, CA				<u>FYTD:</u>	\$3,506.03
QUALITY BOOKS, INC.	217558	06/10/2013	170974	CHILDREN'S SPANISH BOOKS FOR THE LIBRARY-BACKORDER	\$35.86
Remit to: OREGON, IL				<u>FYTD:</u>	\$667.32
RAIMI & ASSOCIATES, INC	217606	06/10/2013	13-640	HIGHWAY 60 CORRIDOR STUDY (PA13-0003)	\$12,992.50
Remit to: BERKELEY, CA				<u>FYTD:</u>	\$12,992.50
RAY SIKES	217670	06/17/2013	1047208	REFUND ADULT SOFTBALL LEAGUE	\$477.00
Remit to: MORENO VALLEY, CA				<u>FYTD:</u>	\$477.00
RAY-RAMIREZ, DARCY L.	217504	06/03/2013	130601	RETIREE MED JUNE '13	\$318.73
Remit to: RIVERSIDE, CA				<u>FYTD:</u>	\$3,506.03
RBF CONSULTING, INC.	9481	06/03/2013	12090507	CONSULTING SERVICES, ENGINEERING - ALESSANDRO MEDIAN	\$1,340.30
Remit to: IRVINE, CA				<u>FYTD:</u>	\$93,079.63
RBF CONSULTING, INC.	9679	06/24/2013	848276	CONSULTING SERVICES, ENGINEERING - CACTUS/NASON	\$1,202.95



**City of Moreno Valley
Payment Register
For Period 6/1/2013 through 6/30/2013**

CHECKS UNDER \$25,000

<u>Vendor Name</u>	<u>Check/EFT Number</u>	<u>Payment Date</u>	<u>Inv Number</u>	<u>Invoice Description</u>	<u>Payment Amount</u>
Remit to: IRVINE, CA					<u>FYTD:</u> \$93,079.63
REBECCA CHIAVETTA	217586	06/10/2013	R13-062323	AS REFUND-MICROCHIP REFUND	\$16.00
Remit to: MORENO VALLEY, CA					<u>FYTD:</u> \$16.00
RECORDED BOOKS	217471	06/03/2013	74610825	AUDIOBOOK FOR LIBRARY CIRCULATION	\$165.92
			74597566	AUDIOBOOK FOR LIBRARY CIRCULATION	
			74596066	AUDIOBOOK FOR LIBRARY CIRCULATION	
			74596063	AUDIOBOOK FOR LIBRARY CIRCULATION	
Remit to: BALTIMORE, MD					<u>FYTD:</u> \$1,010.25
RECORDED BOOKS	217559	06/10/2013	74712133	AUDIOBOOKS FOR LIBRARY CIRCULATION	\$344.15
			74601537	AUDIOBOOK FOR LIBRARY CIRCULATION	
			74691400	AUDIOBOOKS FOR LIBRARY CIRCULATION	
			74692919	SALES TAX ON EAR BUDS FOR AUDIOBOOKS	
			74708625	AUDIOBOOK FOR LIBRARY CIRCULATION	
			74596279	AUDIOBOOK REPLACEMENT CDS FOR LIBRARY	
Remit to: BALTIMORE, MD					<u>FYTD:</u> \$1,010.25
RENE ALVAREZ	217646	06/17/2013	B130000	REFUND-80% BUILDING PERMIT FEE	\$515.75
Remit to: RIVERSIDE, CA					<u>FYTD:</u> \$515.75
REPUBLIC MASTER CHEFS TEXTILE RENTAL SERVICE	9643	06/17/2013	10991173	LINENS RENTAL FOR CRC	\$106.70
			10986000	LINENS RENTAL FOR CRC & SPECIAL EVENTS	
Remit to: LOS ANGELES, CA					<u>FYTD:</u> \$1,777.13



**City of Moreno Valley
Payment Register
For Period 6/1/2013 through 6/30/2013**

CHECKS UNDER \$25,000

<u>Vendor Name</u>	<u>Check/EFT Number</u>	<u>Payment Date</u>	<u>Inv Number</u>	<u>Invoice Description</u>	<u>Payment Amount</u>
RHA LANDSCAPE ARCHITECTS-PLANNERS	217626	06/17/2013	0513013	SHADOW MOUNTAIN PARK RAMP MODIFICATION DESIGN PROJ-REIMB EXPENSE	\$1,846.70
			0513012	SHADOW MOUNTAIN PARK RAMP MODIFICATION DESIGN SERVICES	
Remit to: RIVERSIDE, CA					<u>FYTD:</u> \$5,276.70
RHONDA MAUTNER	217663	06/17/2013	R13-061610	AS REFUND-ADOPT,VACCINES,CHIP,LIC,RABIES DEP	\$102.00
Remit to: MORENO VALLEY, CA					<u>FYTD:</u> \$102.00
RICK ENGINEERING COMPANY	9644	06/17/2013	0031497	CONSULTING SERVICES, SURVEY - SIP KENTLAND WILSON KINNY	\$1,080.00
Remit to: RIVERSIDE, CA					<u>FYTD:</u> \$197,576.96
RICK HARTMANN	217496	06/03/2013	130601	RETIREE MED JUNE '13	\$318.73
Remit to: SAN DIMAS, CA					<u>FYTD:</u> \$2,868.57
RIDGE MORENO VALLEY, LLC	217602	06/10/2013	CFD#4-INFRA	REFUND-CFD#4-INFRASTRUCTURE TRUST ACCT. CLOSED	\$1,194.50
Remit to: LONG BEACH, CA					<u>FYTD:</u> \$1,194.50
RIGHTWAY SITE SERVICES, INC.	217714	06/24/2013	724609	PORTABLE RESTROOMS-EQUESTRIAN CENTER	\$381.30
			724608	PORTABLE RESTROOM-COTTONWOOD GOLF COURSE	
Remit to: LAKE ELSINORE, CA					<u>FYTD:</u> \$6,053.81
RIVERSIDE COUNTY DEPARTMENT OF HEALTH	217627	06/17/2013	HS0000004109	RABIES TESTS-ANIMAL SVCS	\$100.00
Remit to: RIVERSIDE, CA					<u>FYTD:</u> \$1,656.00
RIVERSIDE COUNTY FIRE DEPARTMENT	217472	06/03/2013	231574	CONSTRUCTION SUPPORT COSTS - FIRE STATION #99	\$3,378.19



**City of Moreno Valley
Payment Register
For Period 6/1/2013 through 6/30/2013**

CHECKS UNDER \$25,000

<u>Vendor Name</u>	<u>Check/EFT Number</u>	<u>Payment Date</u>	<u>Inv Number</u>	<u>Invoice Description</u>	<u>Payment Amount</u>
Remit to: PERRIS, CA					<u>FYTD:</u> \$6,757.77
RIVERSIDE COUNTY INFORMATION TECHNOLOGY (RCIT)	217473	06/03/2013	9990023000-1304	800-MHZ RADIO MONTHLY LEASE	\$189.90
Remit to: RIVERSIDE, CA					<u>FYTD:</u> \$25,373.87
RIVERSIDE COUNTY INFORMATION TECHNOLOGY (RCIT)	217715	06/24/2013	SR315577	MATERIAL FOR MVPD - MONITOR ROOM	\$1,503.90
Remit to: RIVERSIDE, CA					<u>FYTD:</u> \$25,373.87
RIVERSIDE COUNTY SHERIFF CIVIL DIVISION-WEST	217474	06/03/2013	2013-00000093	1015 - GARNISHMENT - CREDITOR %	\$156.56
Remit to: RIVERSIDE, CA					<u>FYTD:</u> \$6,192.38
RLZ ENGINEERING	9593	06/10/2013	513	CONSULTING SERVICES, PROJECT MANAGEMENT	\$11,475.00
Remit to: CORONA, CA					<u>FYTD:</u> \$17,287.50
ROCHA, SARA L.	9537	06/03/2013	130601	RETIREE MED MAR-MAY '13 & JUNE-AUG '13 MEDI, PD JUNE '13	\$814.20
Remit to: QUEEN CREEK, AZ					<u>FYTD:</u> \$3,031.30
RODRIGO DELGADILLO	217653	06/17/2013	7009561-05	SOLAR INCENTIVE REBATE	\$11,191.50
Remit to: MORENO VALLEY, CA					<u>FYTD:</u> \$11,191.50
ROGER WOLFSON	217600	06/10/2013	R13-062182	AS REFUND- RABIES & S/N DEPOSITS	\$95.00
Remit to: LOS ANGELES, CA					<u>FYTD:</u> \$95.00
ROGERS, EUGENE	9538	06/03/2013	130601	RETIREE MED JUNE '13	\$318.73



**City of Moreno Valley
Payment Register
For Period 6/1/2013 through 6/30/2013**

CHECKS UNDER \$25,000

<u>Vendor Name</u>	<u>Check/EFT Number</u>	<u>Payment Date</u>	<u>Inv Number</u>	<u>Invoice Description</u>	<u>Payment Amount</u>
Remit to: PEBBLE BEACH, CA					<u>FYTD:</u> \$3,506.03
ROSEEN, ROBERT	217582	06/10/2013	SPRING 2013	TUITION REIMBURSEMENT	\$1,500.00
Remit to: REDLANDS, CA					<u>FYTD:</u> \$1,677.50
ROSEEN, ROBERT	217583	06/10/2013	4/9-4/11/13	TRAVEL PER DIEM - NAB 2013 SHOW/COUNCIL EQUIP UPGRADE RESEARCH	\$177.50
Remit to: REDLANDS, CA					<u>FYTD:</u> \$1,677.50
ROSENOW SPEVACEK GROUP (RSG, INC.)	217560	06/10/2013	0029076	ELIGIBILITY REVIEW - ARANA	\$325.00
Remit to: SANTA ANA, CA					<u>FYTD:</u> \$13,873.98
ROSENOW SPEVACEK GROUP (RSG, INC.)	217628	06/17/2013	0028998	NSP ELIGIBILITY REVIEW SERVICES	\$490.00
Remit to: SANTA ANA, CA					<u>FYTD:</u> \$13,873.98
ROSS, DAVID T.	9539	06/03/2013	130601	RETIREE MED JUNE '13	\$318.73
Remit to: MORENO VALLEY, CA					<u>FYTD:</u> \$3,506.03
ROSSON, LOUIS A.	9540	06/03/2013	130601a 130601	RETIREE MED APR-MAY '13, PD JUNE '13 RETIREE MED JUNE '13	\$366.37
Remit to: PERRIS, CA					<u>FYTD:</u> \$3,116.21
RUSO, JOHN	9541	06/03/2013	130601	RETIREE MED JUNE '13	\$146.32
Remit to: RANCHO MIRAGE, CA					<u>FYTD:</u> \$2,007.87
RUTH ROBLEDO	217667	06/17/2013	R13-060181	AS REFUND-S/N DEPOSIT	\$75.00



**City of Moreno Valley
Payment Register
For Period 6/1/2013 through 6/30/2013**

CHECKS UNDER \$25,000

<u>Vendor Name</u>	<u>Check/EFT Number</u>	<u>Payment Date</u>	<u>Inv Number</u>	<u>Invoice Description</u>	<u>Payment Amount</u>
Remit to: MORENO VALLEY, CA					<u>FYTD:</u> \$75.00
RYMAX ELECTRIC, INC.	217603	06/10/2013	3434	REPAIR SPORTS LIGHTS AND REPLACE LAMPS AT MORRISON PARK	\$5,117.57
Remit to: UPLAND, CA					<u>FYTD:</u> \$9,967.57
SAFEWAY SIGN CO.	9482	06/03/2013	94027	TRAFFIC SIGNS, POSTS, HARDWARE	\$3,072.82
Remit to: ADELANTO, CA					<u>FYTD:</u> \$23,214.45
SALVATION ARMY	217561	06/10/2013	2013-01	CDBG PROGRAM REIMB. FOR FOOD PANTRY PROGRAM	\$6,366.00
Remit to: MORENO VALLEY, CA					<u>FYTD:</u> \$11,366.00
SARAH ORTIZ	217596	06/10/2013	R13-061851	AS REFUND-ADOPT,VACCINES,MICROCHIP	\$67.00
Remit to: MENIFEE, CA					<u>FYTD:</u> \$67.00
SCHIEFELBEIN, LORI C.	217505	06/03/2013	130601	RETIREE MED MAY '13, PD JUNE '13	\$318.73
Remit to: BULLHEAD CITY, AZ					<u>FYTD:</u> \$17,819.78
SCHIEFELBEIN, LORI C.	217629	06/17/2013	MAY 2013	CONSULTANT SVCS-ROTATIONAL TOW PROGRAM	\$948.75
Remit to: BULLHEAD CITY, AZ					<u>FYTD:</u> \$17,819.78
SCHUMAN, MICHAEL	9542	06/03/2013	130601	RETIREE MED JUNE '13	\$318.73
Remit to: RIVERSIDE, CA					<u>FYTD:</u> \$3,506.03
SCOTT FAZEKAS & ASSOCIATES, INC	217475	06/03/2013	16653	PLAN CHECK SERVICES FOR BLDG & SAFETY DEPT.	\$9,770.67
			16692	PLAN CHECK SERVICES FOR BLDG & SAFETY DEPT.	



**City of Moreno Valley
Payment Register
For Period 6/1/2013 through 6/30/2013**

CHECKS UNDER \$25,000

<u>Vendor Name</u>	<u>Check/EFT Number</u>	<u>Payment Date</u>	<u>Inv Number</u>	<u>Invoice Description</u>	<u>Payment Amount</u>
Remit to: IRVINE, CA				<u>FYTD:</u>	\$13,818.67
SECRETARY OF STATE - STMT OF INFO UNIT	217519	06/03/2013	NOTARY EXAM	NOTARY PUBLIC EXAM FEE FOR KARYN KIEFER	\$40.00
Remit to: SACRAMENTO, CA				<u>FYTD:</u>	\$100.00
SECTRAN SECURITY, INC	217716	06/24/2013	13060637 - ENT	ARMORED TRANSPORT SERVICES-MV UTILITY	\$477.00
			13060637 - PR	ARMORED TRANSPORT SERVICES-PARKS & COMM. SVCS	
			13060637 - CH	ARMORED TRANSPORT SERVICES-CITY HALL	
Remit to: LOS ANGELES, CA				<u>FYTD:</u>	\$5,724.00
SHARRETT, SHARON K.	9543	06/03/2013	130601	RETIREE MED JUNE '13	\$173.37
Remit to: ONTARIO, CA				<u>FYTD:</u>	\$1,869.27
SHEANIA COLEMAN	217651	06/17/2013	1045041	REFUND FOR SUMMER YOUTH BASKETBALL	\$70.00
Remit to: MORENO VALLEY, CA				<u>FYTD:</u>	\$70.00
SHELDON, STUART H.	217506	06/03/2013	130601	RETIREE MED JUNE '13	\$318.73
Remit to: MURRIETA, CA				<u>FYTD:</u>	\$3,506.03
SHELL OIL CO.	217476	06/03/2013	065159196305	FUEL PURCHASE-M&O TREE CREW	\$19.52
Remit to: COLUMBUS, OH				<u>FYTD:</u>	\$22,333.75
SHELL OIL CO.	217562	06/10/2013	090043845305	FUEL PURCHASES-SPEC. DISTRICTS STAFF	\$80.00
Remit to: COLUMBUS, OH				<u>FYTD:</u>	\$22,333.75
SHELL OIL CO.	217717	06/24/2013	065124489306	FUEL PURCHASES-PD MOTORCYCLES	\$1,821.17



**City of Moreno Valley
Payment Register
For Period 6/1/2013 through 6/30/2013**

CHECKS UNDER \$25,000

<u>Vendor Name</u>	<u>Check/EFT Number</u>	<u>Payment Date</u>	<u>Inv Number</u>	<u>Invoice Description</u>	<u>Payment Amount</u>
Remit to: COLUMBUS, OH					<u>FYTD:</u> \$22,333.75
SHERRY BROWN	217532	06/03/2013	130601	RETIREE MED JUNE '13	\$318.73
Remit to: MORENO VALLEY, CA					<u>FYTD:</u> \$318.73
SKY PUBLISHING	217563	06/10/2013	13_4_105	1/2 PAGE SHOP MOVAL ADVERTISEMENT/JUNE 27-29 ISSUE	\$857.00
Remit to: MORENO VALLEY, CA					<u>FYTD:</u> \$62,056.00
SKY PUBLISHING	217630	06/17/2013	13_4_107	YOUR VILLA MAGAZINE 1/2 PAGE AD - USED OIL RECYCLING LOCATIONS	\$1,680.00
			13_4_106	YOUR VILLA MAGAZINE 1/2 PAGE AD - BOTTLES AND CANS RECYCLING	
Remit to: MORENO VALLEY, CA					<u>FYTD:</u> \$62,056.00
SLAGERMAN, SUSAN A.	9544	06/03/2013	130601	RETIREE MED APRIL-MAY '13, PD JUNE '13	\$637.46
Remit to: MORENO VALLEY, CA					<u>FYTD:</u> \$3,506.03
SLOVER, JASON	217520	06/03/2013	6/10-6/13/13	TRAVEL PER DIEM FOR DRUG IMPAIRED DRIVER TRAINING COURSE	\$130.00
Remit to: MORENO VALLEY, CA					<u>FYTD:</u> \$130.00
SMITH, MARIA A.	9545	06/03/2013	130601	RETIREE MED JUNE '13	\$318.73
Remit to: MORENO VALLEY, CA					<u>FYTD:</u> \$3,506.03
SOCO GROUP, INC	9646	06/17/2013	696240	FUEL FOR CITY VEHICLES & EQUIPMENT	\$7,109.52
Remit to: PERRIS, CA					<u>FYTD:</u> \$373,580.48
SOPHIA BOBADILLA	217523	06/03/2013	1043620	REFUND FOR TOWNGATE DEPOSIT	\$200.00

Item No. A.7



**City of Moreno Valley
Payment Register
For Period 6/1/2013 through 6/30/2013**

CHECKS UNDER \$25,000

<u>Vendor Name</u>	<u>Check/EFT Number</u>	<u>Payment Date</u>	<u>Inv Number</u>	<u>Invoice Description</u>	<u>Payment Amount</u>
Remit to: MORENO VALLEY, CA				<u>FYTD:</u>	\$200.00
SOUTH COAST AIR QUALITY MGMT DISTRICT	217631	06/17/2013	2595892	AQMD "HOT SPOTS" PROGRAM FEE-CITY HALL (07/2012-06/2013)	\$233.22
			2610787	AQMD "HOT SPOTS" PROGRAM FEE-FIRE ST. #99 (07/2012-06/2013)	
Remit to: DIAMOND BAR, CA				<u>FYTD:</u>	\$4,229.37
SOUTH COAST AIR QUALITY MGMT DISTRICT	217718	06/24/2013	2610828	AQMD "HOT SPOTS" PROGRAM FEE-CRC (07/2012-06/2013)	\$116.61
Remit to: DIAMOND BAR, CA				<u>FYTD:</u>	\$4,229.37
SOUTHERN CALIFORNIA EDISON 1	217478	06/03/2013	MAY-13 6/3/13	ELECTRICITY	\$6,111.56
Remit to: ROSEMEAD, CA				<u>FYTD:</u>	\$3,146,869.57
SOUTHERN CALIFORNIA EDISON 1	217564	06/10/2013	MAY-13 6/10/13	ELECTRICITY	\$5,461.06
Remit to: ROSEMEAD, CA				<u>FYTD:</u>	\$3,146,869.57
SOUTHERN CALIFORNIA GAS CO.	217633	06/17/2013	MAY-2013	GAS CHARGES	\$4,154.72
Remit to: MONTEREY PARK, CA				<u>FYTD:</u>	\$63,301.51
SPARKLETTTS	217634	06/17/2013	7364596 060213	BOTTLED WATER/SVC-CREEKSIDE ELEMENTARY "A CHILD'S PLACE"	\$44.31
			7363683 060213	BOTTLED WATER/SVC-ARMADA ELEMENTARY "A CHILD'S PLACE"	
			7364551 052313	BOTTLED WATER/SVC-SUNNYMEAD ELEMENTARY "A CHILD'S PLACE"	
Remit to: DALLAS, TX				<u>FYTD:</u>	\$1,141.36
SPARKLETTTS	217720	06/24/2013	7387294 060713	BOTTLED WATER/SVC-COTTONWOOD GOLF COURSE	\$5.00



City of Moreno Valley
Payment Register
For Period 6/1/2013 through 6/30/2013

CHECKS UNDER \$25,000

<u>Vendor Name</u>	<u>Check/EFT Number</u>	<u>Payment Date</u>	<u>Inv Number</u>	<u>Invoice Description</u>	<u>Payment Amount</u>
Remit to: DALLAS, TX				<u>FYTD:</u>	\$1,141.36
SPECK, GARY B.	9546	06/03/2013	130601	RETIREE MED JUNE '13	\$318.73
Remit to: MORENO VALLEY, CA				<u>FYTD:</u>	\$3,506.03
SPENCER, MARTHA	9547	06/03/2013	130601	RETIREE MED JUNE '13	\$146.32
Remit to: MORENO VALLEY, CA				<u>FYTD:</u>	\$2,007.87
SPRINT	9595	06/10/2013	634235346-033	CELLULAR PHONE SVC FOR PD SET	\$631.15
			417544340-078	CELLULAR PHONE SVC FOR PD GTF	
Remit to: CAROL STREAM, IL				<u>FYTD:</u>	\$9,348.89
SPRINT	217721	06/24/2013	LCI-171257	CELLULAR TECH EXTRACTION & LOCATOR SVCS	\$30.00
Remit to: KANSAS CITY, MO				<u>FYTD:</u>	\$9,348.89
STANDARD INSURANCE CO	217521	06/03/2013	130601	SUPPLEMENTAL INSURANCE	\$1,916.13
Remit to: PORTLAND, OR				<u>FYTD:</u>	\$376,006.03
STANLEY CONVERGENT SECURITY SOLUTIONS, INC	9596	06/10/2013	10113674	ALARM SYSTEM MONITORING SVCS-TS ANNEX	\$1,049.91
			10106339	ALARM SYSTEM MONITORING SVCS-ANNEX 1 BLDG (FIRE ALARM)	
			10137617	ALARM SYSTEM MONITORING SVCS-ANNEX 1 BLDG (BURGLAR ALARM)	
Remit to: PALATINE, IL				<u>FYTD:</u>	\$49,613.89
STATE BOARD OF EQUALIZATION	9847	06/20/2013	053113	SALES & USE TAX 5/1/13 TO 6/15/13	\$2,540.00

Item No. A.7



**City of Moreno Valley
Payment Register
For Period 6/1/2013 through 6/30/2013**

CHECKS UNDER \$25,000

<u>Vendor Name</u>	<u>Check/EFT Number</u>	<u>Payment Date</u>	<u>Inv Number</u>	<u>Invoice Description</u>	<u>Payment Amount</u>
Remit to: SACRAMENTO, CA				<u>FYTD:</u>	\$26,069.12
STATE DISBURSEMENT UNIT	9614	06/14/2013	2013-00000118	1005 - GARNISHMENT - CHILD SUPPORT*	\$2,091.06
Remit to: WEST SACRAMENTO, CA				<u>FYTD:</u>	\$57,287.98
STATE DISBURSEMENT UNIT	9701	06/28/2013	2013-00000134	1005 - GARNISHMENT - CHILD SUPPORT*	\$2,192.67
Remit to: WEST SACRAMENTO, CA				<u>FYTD:</u>	\$57,287.98
STATE OF CALIF. DEPT OF TRANSPORTATION	217750	06/27/2013	EA 32301	EQUIPMENT FOR TRAFFIC SIGNAL - SR-60/MB	\$1,299.49
Remit to: SAN BERNARDINO, CA				<u>FYTD:</u>	\$21,299.49
STATE OF CALIFORNIA DEPT. OF JUSTICE	217566	06/10/2013	920419	FINGERPRINTING SVCS FOR VOLUNTEERS	\$608.00
			904800	FINGERPRINTING SVCS FOR VOLUNTEERS	
			889585	FINGERPRINTING SVCS FOR VOLUNTEERS	
Remit to: SACRAMENTO, CA				<u>FYTD:</u>	\$36,729.00
STATE OF CALIFORNIA DEPT. OF JUSTICE	217635	06/17/2013	968398 (HR)	FINGERPRINTING SVCS-HR DEPT/EMPLOYMENT RELATED	\$640.00
Remit to: SACRAMENTO, CA				<u>FYTD:</u>	\$36,729.00
STATE OF CALIFORNIA DEPT. OF JUSTICE	217722	06/24/2013	973220	FINGERPRINTING SVCS-PD	\$1,619.00
			968398 (ERF)	FINGERPRINTING SVCS-VOLUNTEER SVCS/ERF	
Remit to: SACRAMENTO, CA				<u>FYTD:</u>	\$36,729.00
STATE OF CALIFORNIA DEPT. OF JUSTICE	217723	06/24/2013	968398 (C. PTRL)	FINGERPRINTING SVCS-CITZ. PATROL VOLUNTEERS	\$128.00



**City of Moreno Valley
Payment Register
For Period 6/1/2013 through 6/30/2013**

CHECKS UNDER \$25,000

<u>Vendor Name</u>	<u>Check/EFT Number</u>	<u>Payment Date</u>	<u>Inv Number</u>	<u>Invoice Description</u>	<u>Payment Amount</u>
Remit to: SACRAMENTO, CA				<u>FYTD:</u>	\$36,729.00
STENO SOLUTIONS TRANSCRIPTION SVCS., IN	9682	06/24/2013	42534	TRANSCRIPTION SERVICES FOR PD	\$3,486.72
			42550	TRANSCRIPTION SERVICES FOR PD	
Remit to: CORONA, CA				<u>FYTD:</u>	\$31,583.68
STEVE SALAIZ	217743	06/24/2013	JUN-2013	INSTRUCTOR SVCS-TAE KWON DO CLASS	\$39.00
Remit to: MIRA LOMA, CA				<u>FYTD:</u>	\$273.00
STEWART, CLIFFORD	9548	06/03/2013	130601	RETIREE MED JUNE '13	\$210.74
Remit to: GLENDALE, AZ				<u>FYTD:</u>	\$2,621.64
STILES ANIMAL REMOVAL, INC.	217567	06/10/2013	101548	LARGE ANIMAL CARCASS REMOVAL	\$150.00
Remit to: GUASTI, CA				<u>FYTD:</u>	\$900.00
STK ARCHITECTURE, INC.	9484	06/03/2013	19770	ANNEX 1 REDESIGN & RENOVATION PROJECT REIMBURSABLES	\$1,468.69
Remit to: TEMECULA, CA				<u>FYTD:</u>	\$243,599.28
STK ARCHITECTURE, INC.	9648	06/17/2013	19774	CONSULTING SERVICES, DESIGN - CITY 2ND LEVEL	\$12,977.71
			19772	CONSULTING SERVICES, DESIGN - CITY HALL 2ND LEVEL	
			19737	CONSULTING SERVICES, DESIGN - CITY HALL 2ND LEVEL	
			19771	CONSULTING SERVICES, DESIGN - CITY HALL 2ND LEVEL	
Remit to: TEMECULA, CA				<u>FYTD:</u>	\$243,599.28
STK ARCHITECTURE, INC.	9683	06/24/2013	19803	CONSULTING SERVICES, DESIGN - CITY HALL 2ND LEVEL	\$10,070.96
			19717	CONSULTING SERVICES, DESIGN - FS NO. 6 STORAGE	



**City of Moreno Valley
Payment Register
For Period 6/1/2013 through 6/30/2013**

CHECKS UNDER \$25,000

<u>Vendor Name</u>	<u>Check/EFT Number</u>	<u>Payment Date</u>	<u>Inv Number</u>	<u>Invoice Description</u>	<u>Payment Amount</u>
STK ARCHITECTURE, INC.	9683	06/24/2013	19718	CONSULTING SERVICES, DESIGN - FS NO. 6 STORAGE	\$10,070.96
			19775	CONSULTING SERVICES, DESIGN - FS NO. 6 STORAGE	
			19805	CONSULTING SERVICES, DESIGN - CITY HALL 2ND LEVEL	
			19804	CONSULTING SERVICES, DESIGN - CITY HALL 2ND LEVEL	
			19776	CONSULTING SERVICES, DESIGN - FS NO. 6 STORAGE	
Remit to: TEMECULA, CA					FYTD: \$243,599.28
STRADLING, YOCCA, CARLSON & RAUTH	9684	06/24/2013	280110-0032	LEGAL SERVICES	\$2,744.48
			280109-0031	LEGAL SERVICES	
Remit to: NEWPORT BEACH, CA					FYTD: \$106,063.91
STREICH, TERRY L.	9549	06/03/2013	130601	RETIREE MED VSP JUNE '13, PD JUNE '13	\$30.33
Remit to: MORENO VALLEY, CA					FYTD: \$2,193.21
STRICKLER ASSOCIATION, THE	9597	06/10/2013	4900	SURPLUS PROPERTY CONSULTING SERVICES	\$1,162.50
Remit to: SAN BERNARDINO, CA					FYTD: \$18,314.98
STRICKLER ASSOCIATION, THE	9685	06/24/2013	4800	CONSULTANT SVCS-HABITAT FOR HUMANITY PROJECT	\$97.50
Remit to: SAN BERNARDINO, CA					FYTD: \$18,314.98
SUNNYMEAD ACE HARDWARE	217480	06/03/2013	49026	MISC. SUPPLIES FOR FIRE STATION	\$34.51
			51426	MISC. SUPPLIES FOR FIRE STATION 48-3 KEYS FOR STATION	
Remit to: MORENO VALLEY, CA					FYTD: \$1,623.03
SUNNYMEAD ACE HARDWARE	217568	06/10/2013	51791	MISC. SUPPLIES FOR PD	\$43.13
			51721	MISC. SUPPLIES FOR PD	



City of Moreno Valley
Payment Register
For Period 6/1/2013 through 6/30/2013

CHECKS UNDER \$25,000

<u>Vendor Name</u>	<u>Check/EFT Number</u>	<u>Payment Date</u>	<u>Inv Number</u>	<u>Invoice Description</u>	<u>Payment Amount</u>
Remit to: MORENO VALLEY, CA					<u>FYTD:</u> \$1,623.03
SUNNYMEAD ACE HARDWARE	217724	06/24/2013	51812	MISC. SUPPLIES FOR PD	\$28.57
			51801	MISC. SUPPLIES FOR PD	
			51802	MISC. SUPPLIES FOR PD	
Remit to: MORENO VALLEY, CA					<u>FYTD:</u> \$1,623.03
SUNNYMEAD ANIMAL HOSPITAL	217725	06/24/2013	247556	VETERINARY CARE/SVCS FOR PATROL K-9 IVAN	\$30.00
Remit to: MORENO VALLEY, CA					<u>FYTD:</u> \$307.50
TAMARA PITTMAN	217666	06/17/2013	R13-061543	AS REFUND-RABIES (2) & S/N DEPOSITS	\$115.00
Remit to: LOS ANGELES, CA					<u>FYTD:</u> \$115.00
TAX COMPLIANCE SERVICES	217481	06/03/2013	2012-2013 STMT10	UUT AUDIT & CONSULTING SERVICES	\$5,000.00
Remit to: THOUSAND OAKS, CA					<u>FYTD:</u> \$55,000.00
TAYLER GRANT	217658	06/17/2013	1047049	REFUND PEE WEE TBALL AND JR TBALL	\$132.00
Remit to: MORENO VALLEY, CA					<u>FYTD:</u> \$132.00
TERRI BILTON	217648	06/17/2013	489104	REFUND DOG TRAINING	\$77.00
Remit to: MORENO VALLEY, CA					<u>FYTD:</u> \$77.00
THE PENWORTHY COMPANY	9598	06/10/2013	259856	CHILDREN'S BOOKS FOR THE LIBRARY	\$398.23
Remit to: MILWAUKEE, WI					<u>FYTD:</u> \$2,179.76
THERMAL COMBUSTION INNOVATORS	217482	06/03/2013	107713	BIOHAZARD MEDICAL WASTE DISPOSAL SVCS FOR ANIMAL SHELTER	\$88.03



**City of Moreno Valley
Payment Register
For Period 6/1/2013 through 6/30/2013**

CHECKS UNDER \$25,000

<u>Vendor Name</u>	<u>Check/EFT Number</u>	<u>Payment Date</u>	<u>Inv Number</u>	<u>Invoice Description</u>	<u>Payment Amount</u>
Remit to: COLTON, CA				<u>FYTD:</u>	\$1,033.29
THINK TOGETHER, INC.	217672	06/17/2013	1049032	REFUND FOR TOWNGATE DEPOSIT	\$200.00
Remit to: MORENO VALLEY, CA				<u>FYTD:</u>	\$200.00
THOMAS/KAYLENE ALVAREZ	217584	06/10/2013	R13-062421	AS REFUND-TRAP DEPOSIT	\$50.00
Remit to: MORENO VALLEY, CA				<u>FYTD:</u>	\$50.00
THOMPSON COBURN LLP	9485	06/03/2013	2528626	LEGAL SVCS FOR MVU	\$33.50
Remit to: WASHINGTON, DC				<u>FYTD:</u>	\$7,370.48
TIME WARNER CABLE	217483	06/03/2013	031518001 5/3/13	CABLE TV SERVICE FOR COTTONWOOD GOLF COURSE	\$61.90
Remit to: CORONA, CA				<u>FYTD:</u>	\$123.80
TIME WARNER CABLE	217636	06/17/2013	031518001 6/1/13	CABLE TV SERVICE FOR COTTONWOOD GOLF COURSE	\$61.90
Remit to: PITTSBURGH, PA				<u>FYTD:</u>	\$123.80
TIME WARNER CABLE 2	217484	06/03/2013	8448400551506863	CABLE/BROADBAND SERVICE FOR FIRE ST. 58 TRAINING ROOM	\$401.46
Remit to: CITY OF INDUSTRY, CA				<u>FYTD:</u>	\$602.19
TIME WARNER CABLE 2	217726	06/24/2013	6/5/13 STMT	CABLE/BROADBAND SVC-FIRE ST. 58 TRNG RM-ACCT #8448400551506863	\$200.73
Remit to: CITY OF INDUSTRY, CA				<u>FYTD:</u>	\$602.19
TIMOTHY BROWN	217746	06/24/2013	00009538	REFUND DUPLICATE PAYMENT	\$88.26
Remit to: REDLANDS, CA				<u>FYTD:</u>	\$88.26



**City of Moreno Valley
Payment Register
For Period 6/1/2013 through 6/30/2013**

CHECKS UNDER \$25,000

<u>Vendor Name</u>	<u>Check/EFT Number</u>	<u>Payment Date</u>	<u>Inv Number</u>	<u>Invoice Description</u>	<u>Payment Amount</u>
TIMOTHY CARROLL	217580	06/10/2013	4/9-4/11/13	MILEAGE & PER DIEM-NAB 2013 SHOW/COUNCIL EQUIP UPGRADE RESEARCH	\$460.00
Remit to: LA HABRA, CA					
TKE ENGINEERING INC	217637	06/17/2013	2012-261	CONSULTING SERVICES, ENGINEERING - DRACAEA/PERRIS TO PATRICIA	\$1,220.00
Remit to: RIVERSIDE, CA					
TMAD TAYLOR & GAINES ENGINEERS	217485	06/03/2013	0007726	GRANT APPLICATION ASSISTANCE - HIGHWAY BRIDGE MAINTENANCE	\$10,000.00
Remit to: PASADENA, CA					
TMAD TAYLOR & GAINES ENGINEERS	217727	06/24/2013	00078107	PROFESSIONAL ENGINEERING SERVICES - EOC GENERATOR	\$24,446.40
Remit to: PASADENA, CA					
TR DESIGN GROUP, INC.	9599	06/10/2013	1755	ARCHITECTURAL SERVICES-PD BALLISTIC GLASS PROJECT REIMBURSABLES	\$6,198.35
Remit to: RIVERSIDE, CA					
TRICHE, TARA	217744	06/24/2013	JUN-2013	ARCHITECTURAL SERVICES-PD BALLISTIC GLASS PROJECT INSTRUCTOR SVCS-DANCE CLASSES	\$1,998.00
Remit to: MORENO VALLEY, CA					
TROPICAL PLAZA NURSERY, INC.	9600	06/10/2013	M51866	LANDSCAPE MAINT.-ZONE E-2	\$6,101.66
Remit to: MORENO VALLEY, CA					
				FYTD:	\$48,046.40
				FYTD:	\$4,122.50
				FYTD:	\$48,046.40
				FYTD:	\$32,317.50
				FYTD:	\$26,402.40



**City of Moreno Valley
Payment Register
For Period 6/1/2013 through 6/30/2013**

CHECKS UNDER \$25,000

<u>Vendor Name</u>	<u>Check/EFT Number</u>	<u>Payment Date</u>	<u>Inv Number</u>	<u>Invoice Description</u>	<u>Payment Amount</u>
Remit to: VILLA PARK, CA				<u>FYTD:</u>	\$119,246.27
TROPICAL PLAZA NURSERY, INC.	9687	06/24/2013	M52028	LANDSCAPE MAINT.-ZONE E-2	\$21,080.90
			M51955	ANNUAL WEED ABATEMENT-HIDDEN SPRINGS/ZONE E-2	
			M51972	LANDSCAPE WORK-4' BUFFER ZONE BEHIND HOMES-ZONE E-2/PASEO AREAS	
			M51977	IRRIGATION REPAIRS-ZONE E-2	
Remit to: VILLA PARK, CA				<u>FYTD:</u>	\$119,246.27
TROY ALARM INC.	217728	06/24/2013	51411	FIRE ALARM SERVICES - MORRISON PARK FS	\$366.00
Remit to: RIVERSIDE, CA				<u>FYTD:</u>	\$366.00
TWRITE, INC.	217729	06/24/2013	13-0129	WEBMASTER SERVICES-COMPLEX PROGRAMMING FOR CSD LOOK UP	\$14,133.75
			13-0128	WEBMASTER SERVICES-CITY WEBSITE MAINTENANCE	
			13-0127	WEBMASTER SERVICES-CITY WEBSITE MAINTENANCE	
Remit to: RIVERSIDE, CA				<u>FYTD:</u>	\$14,133.75
U.S. HEALTHWORKS MEDICAL GROUP	217570	06/10/2013	2271876-CA	EMPLOYMENT DOT/DRUG SCREENING EXAMS	\$230.00
			2279278-CA	EMPLOYMENT DOT/DRUG SCREENING EXAMS	
Remit to: LOS ANGELES, CA				<u>FYTD:</u>	\$3,844.26
UNDERGROUND SERVICE ALERT	9688	06/24/2013	520130443 d	DIGALERT TICKETS SUBSCRIPTION SERVICE	\$439.50
			520130443 a	DIGALERT TICKETS SUBSCRIPTION SERVICE	
			520130443 b	DIGALERT TICKETS SUBSCRIPTION SERVICE	
			520130443 c	DIGALERT TICKETS SUBSCRIPTION SERVICE	



**City of Moreno Valley
Payment Register
For Period 6/1/2013 through 6/30/2013**

CHECKS UNDER \$25,000

<u>Vendor Name</u>	<u>Check/EFT Number</u>	<u>Payment Date</u>	<u>Inv Number</u>	<u>Invoice Description</u>	<u>Payment Amount</u>
Remit to: CORONA, CA					<u>FYTD:</u> \$4,911.00
UNION BANK OF CALIFORNIA 1	217571	06/10/2013	806111	INVESTMENT SAFEKEEPING SERVICES	\$291.67
Remit to: SAN DIEGO, CA					<u>FYTD:</u> \$3,242.70
UNITED ROTARY BRUSH CORP	9486	06/03/2013	275423	STREET SWEEPER REPAIR PARTS	\$916.38
			275443	STREET SWEEPER BROOM KITS/RECONDITIONING	
Remit to: ESCONDIDO, CA					<u>FYTD:</u> \$36,691.73
UNITED ROTARY BRUSH CORP	9602	06/10/2013	27558	STREET SWEEPER BROOM KITS/RECONDITIONING	\$2,746.89
			275540	STREET SWEEPER REPAIR PARTS	
			275543	STREET SWEEPER REPAIR PARTS	
			275572	STREET SWEEPER BROOM KITS/RECONDITIONING & REPAIR PARTS	
Remit to: ESCONDIDO, CA					<u>FYTD:</u> \$36,691.73
UNITED ROTARY BRUSH CORP	9650	06/17/2013	275613	STREET SWEEPER BROOM KITS/RECONDITIONING & REPAIR PARTS	\$1,012.30
Remit to: ESCONDIDO, CA					<u>FYTD:</u> \$36,691.73
UNITED WAY OF INLAND VALLEYS	217486	06/03/2013	2013-00000094	8720 - UNITED WAY	\$261.00
Remit to: RIVERSIDE, CA					<u>FYTD:</u> \$9,187.00
UNITED WAY OF INLAND VALLEYS	217638	06/17/2013	2013-00000114	8720 - UNITED WAY	\$261.00
Remit to: RIVERSIDE, CA					<u>FYTD:</u> \$9,187.00
UNIVAR USA, INC	217572	06/10/2013	RV565913	AG CHEMICALS/FERTILIZER FOR PARKS/CFD #1/CONTRACT AREAS	\$4,816.43



City of Moreno Valley
Payment Register
 For Period 6/1/2013 through 6/30/2013

CHECKS UNDER \$25,000

<u>Vendor Name</u>	<u>Check/EFT Number</u>	<u>Payment Date</u>	<u>Inv Number</u>	<u>Invoice Description</u>	<u>Payment Amount</u>
Remit to: LOS ANGELES, CA				<u>FYTD:</u>	\$16,855.32
URBAN CROSSROADS, INC.	217730	06/24/2013	23917	TUMF NETWORK UPDATE	\$6,902.50
			24127	CONSTRUCTION SUPPORT SERVICES - CACTUS/NASON	
			24121	TUMF NETWORK UPDATES	
Remit to: IRVINE, CA				<u>FYTD:</u>	\$21,460.00
USA MOBILITY/ARCH WIRELESS	9651	06/17/2013	W6218870F	PAGER SERVICE	\$34.68
Remit to: SPRINGFIELD, VA				<u>FYTD:</u>	\$435.53
VACATE PEST ELIMINATION COMPANY	9603	06/10/2013	41512	PEST CONTROL SERVICE-CONFERENCE & REC CTR	\$1,260.00
			41501	PEST CONTROL SERVICE-TOWNGATE COMM. CTR.	
			41503	PEST CONTROL SERVICE-UTILITY FIELD OFFICE	
			41373	PEST CONTROL SERVICE-FIRE ST. #91	
			41500	PEST CONTROL SERVICE-FIRE ST. #48	
			41505	PEST CONTROL SERVICE-FIRE ST. #6	
			41506	PEST CONTROL SERVICE-LIBRARY	
			41507	PEST CONTROL SERVICE-FIRE ST. #58	
			41502	PEST CONTROL SERVICE-FIRE ST. #99	
			41509	PEST CONTROL SERVICE-FIRE ST. #2	
			41682	PEST CONTROL SERVICE-GOLF COURSE PRO SHOP	
			41683	PEST CONTROL SERVICE-CITY HALL	
			41691	PEST CONTROL SERVICE-MARCH FIELD PARK COMM. CTR.	
			41470	PEST CONTROL SERVICE-FIRE ST. #65	
			41508	PEST CONTROL SERVICE-SENIOR CENTER	



**City of Moreno Valley
Payment Register
For Period 6/1/2013 through 6/30/2013**

CHECKS UNDER \$25,000

<u>Vendor Name</u>	<u>Check/EFT Number</u>	<u>Payment Date</u>	<u>Inv Number</u>	<u>Invoice Description</u>	<u>Payment Amount</u>
VACATE PEST ELIMINATION COMPANY	9603	06/10/2013	41692	PEST CONTROL SERVICE-TRANSP. TRAILER	\$1,260.00
			41684	PEST CONTROL SERVICE-CITY YARD	
			41690	PEST CONTROL SERVICE-MARCH FIELD BLDG 823	
			41689	PEST CONTROL SERVICE-ANIMAL SHELTER	
			41688	PEST CONTROL SERVICE-ANNEX 1 BLDG	
			41686	PEST CONTROL SERVICE-EOC	
			41685	PEST CONTROL SERVICE-PUBLIC SAFETY BLDG	
Remit to: MORENO VALLEY, CA					FYTD: \$18,485.00
VARIABLE SPEEDS SOLUTIONS INC	9604	06/10/2013	9626	EMERGENCY PUMP REPAIR - TRACT 32625	\$2,028.00
			9662	EMERGENCY PUMP REPAIR - ZONE E-14	
Remit to: HUNTINGTON BEACH, CA					FYTD: \$5,543.00
VASQUEZ, CAROL	217507	06/03/2013	130601	RETIREE MED APRIL '13, PD JUNE '13	\$318.73
Remit to: RIALTO, CA					FYTD: \$1,593.65
VERIZON	217639	06/17/2013	EQN6913105-13148	BACKBONE COMMUNICATION CHARGES	\$1,744.75
Remit to: TRENTON, NJ					FYTD: \$21,102.02
VICTOR MEDICAL CO	217573	06/10/2013	3313687	ANIMAL MEDICAL SUPPLIES/VACCINES	\$1,042.76
Remit to: LAKE FOREST, CA					FYTD: \$28,690.51
VIGIL, ERNEST	9551	06/03/2013	130601	RETIREE MED JUNE '13	\$318.73
Remit to: MORENO VALLEY, CA					FYTD: \$3,506.03
VINCENT, CLARENCE	217508	06/03/2013	130601	RETIREE MED MAY '13, PD JUNE '13	\$318.73



**City of Moreno Valley
Payment Register
For Period 6/1/2013 through 6/30/2013**

CHECKS UNDER \$25,000

<u>Vendor Name</u>	<u>Check/EFT Number</u>	<u>Payment Date</u>	<u>Inv Number</u>	<u>Invoice Description</u>	<u>Payment Amount</u>
Remit to: MORENO VALLEY, CA					<u>FYTD:</u> \$18,711.79
VISION SERVICE PLAN	9487	06/03/2013	130601	EMPLOYEE VISION INSURANCE	\$3,889.20
Remit to: SAN FRANCISCO, CA					<u>FYTD:</u> \$47,025.62
VISTA PAINT CORPORATION	217574	06/10/2013	2013-737815-00	PAINT FOR CITY PARKS	\$820.86
			2013-743500-00	PAINT/SUPPLIES FOR EQUESTRIAN CENTER	
Remit to: FULLERTON, CA					<u>FYTD:</u> \$44,805.87
VOYAGER FLEET SYSTEM, INC.	9605	06/10/2013	869211615317	CNG FUEL PURCHASES	\$2,348.63
Remit to: HOUSTON, TX					<u>FYTD:</u> \$25,056.67
VOYAGER FLEET SYSTEM, INC.	9652	06/17/2013	869211615321	CNG FUEL PURCHASES	\$2,408.13
Remit to: HOUSTON, TX					<u>FYTD:</u> \$25,056.67
VULCAN MATERIALS CO, INC.	217640	06/17/2013	350487	ASPHALTIC MATERIALS	\$2,952.42
			365067	ASPHALTIC MATERIALS	
			367578	ASPHALTIC MATERIALS	
			361921	ASPHALTIC MATERIALS	
			354176	ASPHALTIC MATERIALS	
			339264	ASPHALTIC MATERIALS	
			339265	ASPHALTIC MATERIALS	
			350488	ASPHALTIC MATERIALS	
			350486	ASPHALTIC MATERIALS	
			348115	ASPHALTIC MATERIALS	
			345792	ASPHALTIC MATERIALS	



**City of Moreno Valley
Payment Register
For Period 6/1/2013 through 6/30/2013**

CHECKS UNDER \$25,000

<u>Vendor Name</u>	<u>Check/EFT Number</u>	<u>Payment Date</u>	<u>Inv Number</u>	<u>Invoice Description</u>	<u>Payment Amount</u>
VULCAN MATERIALS CO, INC.	217640	06/17/2013	345791	ASPHALTIC MATERIALS	\$2,952.42
			341543	ASPHALTIC MATERIALS	
			354175	ASPHALTIC MATERIALS	
Remit to: LOS ANGELES, CA					
	9552	06/03/2013	130601	RETIREE MED APRIL '13, PD JUNE '13	FYTD: \$24,142.46
WAGGONER JR., GLENN C.					
Remit to: RIVERSIDE, CA					
	9553	06/03/2013	130601	RETIREE MED JUNE '13	FYTD: \$318.73
WAGNER, GARY D.					
Remit to: MORENO VALLEY, CA					
	9554	06/03/2013	130601	RETIREE MED JUNE '13	FYTD: \$3,506.03
WAGNER, MARIANNE K					
Remit to: MORENO VALLEY, CA					
	217509	06/03/2013	130601	RETIREE MED MAR-APR '13, PD JUNE '13	FYTD: \$1,912.38
WAGY, CARYLON					
Remit to: MORENO VALLEY, CA					
	217745	06/24/2013	10503587	LEGAL SERVICES - BOND SAFEGUARD CASE	FYTD: \$2,542.42
WALLER LANSDEN DORTCH & DAVIS LLP					
Remit to: NASHVILLE, TN					
	217576	06/10/2013	960138	ANNUAL TRUSTEE FEE-CFD NO. 5 2007 TAX BONDS 5/31/13-5/30/14	FYTD: \$602.70
WELLS FARGO CORPORATE					
Remit to: MINNEAPOLIS, MN					
	9653	06/17/2013	88191	TREE TRIMMING SERVICES -VARIOUS LOCATIONS IN THE CITY	FYTD: \$2,000.00
WEST COAST ARBORISTS, INC.					
			88192	TREE TRIMMING & REMOVAL SERVICES-PARKS & CONTRACT AREAS	FYTD: \$8,993,898.70



**City of Moreno Valley
Payment Register
For Period 6/1/2013 through 6/30/2013**

CHECKS UNDER \$25,000

<u>Vendor Name</u>	<u>Check/EFT Number</u>	<u>Payment Date</u>	<u>Inv Number</u>	<u>Invoice Description</u>	<u>Payment Amount</u>
Remit to: ANAHEIM, CA					<u>FYTD:</u> \$125,370.00
WEST PAYMENT CENTER	217487	06/03/2013	827226635	LEGAL LIBRARY PUBLICATIONS UPDATES	\$190.08
Remit to: CAROL STREAM, IL					<u>FYTD:</u> \$14,220.60
WESTERN MUNICIPAL WATER DISTRICT	217731	06/24/2013	23821-018258/MAY	WATER CHARGES-MFPCC BLDG 938	\$3,403.48
			24753-018620/MAY	WATER CHARGES-MARB BALLFIELDS	
			23821-018257/MAY	WATER CHARGES-MFPCC LANDSCAPE	
			23866-018292/MAY	WATER CHARGES-SKATE PARK	
Remit to: ARTESIA, CA					<u>FYTD:</u> \$29,281.04
WIBERG, CHRISTOPHER	217510	06/03/2013	130601	RETIREE MED JUNE '13	\$318.73
Remit to: ANAHEIM, CA					<u>FYTD:</u> \$3,506.03
WIELIN, RONALD A.	9555	06/03/2013	130601	RETIREE MED JUNE '13	\$318.73
Remit to: BANNING, CA					<u>FYTD:</u> \$3,506.03
WILLDAN FINANCIAL SERVICES	9689	06/24/2013	010-20899	CSD ZONE B BENEFIT ANALYSIS SERVICES	\$7,410.00
			010-20888	CSD ZONE B BENEFIT ANALYSIS SERVICES	
Remit to: TEMECULA, CA					<u>FYTD:</u> \$44,418.00
WILLIAMS, JANE L.	9556	06/03/2013	130601	RETIREE MED APR-MAY '13, PD JUNE '13	\$391.88
Remit to: GRAND FORKS, ND					<u>FYTD:</u> \$2,003.84
WILLIS, ROBERT H	217732	06/24/2013	060613	SPORTS OFFICIATING SERVICES-SOFTBALL	\$120.00
			060213	SPORTS OFFICIATING SERVICES-SOFTBALL	



**City of Moreno Valley
Payment Register
For Period 6/1/2013 through 6/30/2013**

CHECKS UNDER \$25,000

<u>Vendor Name</u>	<u>Check/EFT Number</u>	<u>Payment Date</u>	<u>Inv Number</u>	<u>Invoice Description</u>	<u>Payment Amount</u>
Remit to: PERRIS, CA				<u>FYTD:</u>	\$2,220.00
WILSON-BEILKE, DENESE	217511	06/03/2013	130601	RETIREE MED JUNE '13	\$318.73
Remit to: GLENDORA, CA				<u>FYTD:</u>	\$4,780.95
WRCOG WESTERN RIVERSIDE CO. OF GOVT'S.	217578	06/10/2013	6431	SPONSORSHIP OF WRCOG 2013 GENERAL ASSEMBLY & LEADERSHIP ADDRESS	\$2,000.00
Remit to: RIVERSIDE, CA				<u>FYTD:</u>	\$1,548,207.56
WRCRCA	217641	06/17/2013	MAY-2013 MSHCP	MSHCP FEES COLLECTED FOR MAY 2013	\$4,551.93
Remit to: RIVERSIDE, CA				<u>FYTD:</u>	\$424,758.06
WURM'S JANITORIAL SERVICES, INC.	9606	06/10/2013	22161	CARPET CLEANING FOR FIRE STATIONS	\$2,449.00
Remit to: CORONA, CA				<u>FYTD:</u>	\$306,123.06
WURM'S JANITORIAL SERVICES, INC.	9690	06/24/2013	22282	JANITORIAL SVCS-CITY HALL	\$23,885.11
	22297			JANITORIAL SVCS-ANNEX 1	
	22296			JANITORIAL SVCS-TOWNGATE COMM. CTR.	
	22294			JANITORIAL SVCS-SUNNYMEAD MIDDLE SCHOOL/ASES (TO 6/7/13)	
	22295			JANITORIAL SVCS-SUNNYMEAD ELEMENTARY FOR "A CHILD'S PLACE"	
	22292			JANITORIAL SVCS-RED MAPLE FOR "A CHILD'S PLACE"	
	22284			JANITORIAL SVCS-CONFERENCE & REC. CTR.	
	22316			SPECIAL CLEANINGS FOR EVENT RENTALS AT CRC	
	22293			JANITORIAL SVCS-SENIOR CENTER	



**City of Moreno Valley
Payment Register
For Period 6/1/2013 through 6/30/2013**

CHECKS UNDER \$25,000

<u>Vendor Name</u>	<u>Check/EFT Number</u>	<u>Payment Date</u>	<u>Inv Number</u>	<u>Invoice Description</u>	<u>Payment Amount</u>
WURM'S JANITORIAL SERVICES, INC.	9690	06/24/2013	22319	OVEN/STOVE CLEANING IN KITCHEN OF CRC GRAND BALLROOM	\$23,885.11
			22283	JANITORIAL SVCS-CITY YARD & TRANSP. TRAILER	
			22290	JANITORIAL SVCS-GANG TASK FORCE OFFICE	
			22291	JANITORIAL SVCS-RAINBOW RIDGE FOR "A CHILD'S PLACE"	
			22317	SPECIAL CLEANINGS FOR EVENT RENTALS AT SENIOR CENTER	
			22289	JANITORIAL SVCS-PUBLIC SAFETY BLDG	
			22288	JANITORIAL SVCS-MARCH FIELD PARK COMM. CTR.	
			22285	JANITORIAL SVCS-EOC	
			22287	JANITORIAL SVCS-LIBRARY	
Remit to: CORONA, CA					FYTD: \$306,123.06
XEROX CAPITAL SERVICES, LLC	217488	06/03/2013	068065039	COPIER LEASE/BILLABLE PRINTS FOR GRAPHICS DEPT.	\$2,530.79
			067978039	COPIER LEASE/BILLABLE PRINTS FOR PARKS DEPT.	
Remit to: PASADENA, CA					FYTD: \$44,818.60
XEROX CAPITAL SERVICES, LLC	217579	06/10/2013	068368430	COPIER RENTAL/MAINT.-PD	\$84.16
Remit to: PASADENA, CA					FYTD: \$44,818.60
XEROX CAPITAL SERVICES, LLC	217733	06/24/2013	068368431	COPIER LEASE/BILLABLE PRINTS FOR PARKS DEPT.	\$2,044.71
			068368432	COPIER LEASE FOR PARKS DEPT.	
Remit to: PASADENA, CA					FYTD: \$44,818.60
XYLINA THERRIEN	217685	06/17/2013	MV4111219004	REFUND-CITATION OVERPAYMENT	\$58.00
Remit to: MORENO VALLEY, CA					FYTD: \$58.00



City of Moreno Valley
Payment Register
 For Period 6/1/2013 through 6/30/2013

CHECKS UNDER \$25,000

<u>Vendor Name</u>	<u>Check/EFT Number</u>	<u>Payment Date</u>	<u>Inv Number</u>	<u>Invoice Description</u>	<u>Payment Amount</u>
YAMASHITA, JULIA J.	9557	06/03/2013	130601	RETIREE MED APRIL '13, PD JUNE '13	\$146.90
Remit to: LAGUNA WOODS, CA					<u>FYTD:</u> \$1,427.00
ZUMAR INDUSTRIES, INC.	9489	06/03/2013	0144844	SIGN SUPPLIES/3M 2-WAY YELLOW & 1-WAY WHITE RPM	\$9,460.80
Remit to: SANTA FE SPRINGS, CA					<u>FYTD:</u> \$10,710.79
TOTAL CHECKS UNDER \$25,000					\$1,164,703.75
GRAND TOTAL					\$22,008,214.83

This page intentionally left blank.



APPROVALS	
BUDGET OFFICER	<i>me</i>
CITY ATTORNEY	<i>SMB</i>
CITY MANAGER	<i>d</i>

Report to City Council

TO: Mayor and City Council

FROM: Richard Teichert, Chief Financial Officer

AGENDA DATE: August 27, 2013

TITLE: RECEIPT OF QUARTERLY INVESTMENT REPORT – QUARTER ENDED JUNE 30, 2013

RECOMMENDED ACTION

Recommendation:

1. Receive and file the Quarterly Investment Report, in compliance with the City's Investment Policy.

ADVISORY BOARD/COMMISSION RECOMMENDATION

Not Applicable

BACKGROUND

California Government Code Sections 53601 and 53646 establish the types of investments allowed, the governing restrictions on these investments, the third-party custodian arrangement for certain investments, and the reporting practices related to the portfolio for local agencies. The City's Investment Policy, adopted on July 9, 2013, is in full compliance with the requirements of both of the above-mentioned Code Sections.

DISCUSSION

The attached Quarterly Investment Report presents the City's cash and investments for the quarter that ended June 30, 2013. This is the fourth quarterly report submitted for the 2012-13 fiscal year and is in compliance with California Government Code Section 53646 regarding the reporting of detailed information on all securities, investments, and monies of the City, as well as the reporting of the market value of the investments held.

All of the investments contained within the portfolio are in full compliance with the City's Investment Policy and Government Code Section 53601 as to the types of investments allowed. As stated in the attached report, there is more than adequate liquidity within the portfolio for the City to meet its budgeted expenditures over the next six months.

The City has used Chandler Asset Management as its professional portfolio manager since 2010. Chandler uses an active investment management approach. Utilizing an active approach, securities purchased by Chandler on the City's behalf are not necessarily held to maturity but may be actively traded based on market conditions and the City's investment goals. The City's cash flow requirements are evaluated on an ongoing basis, with short-term needs accommodated through the City's pooled investment funds with the State Local Agency Investment Fund (LAIF). LAIF is a pool of public funds managed by the State Treasurer of California, providing 24-hour liquidity while yielding a rate of return approximately equivalent to a one-year treasury bill. With the combined use of a conservative approach to evaluating cash flow needs and LAIF liquidity, the City will not have to liquidate securities at current market rates that are intended to be held for longer-term investment. This is especially important considering that the average maturity of the general portfolio is 2.44 years.

The investments managed by Chandler Asset Management totaled \$146,817,918 at par and achieved a Yield to Maturity (YTM) for June 2013 of 1.25%. This compares to a YTM in March 2013 of 1.28% and a YTM in June 2012 of 1.31%. In addition, the City maintained \$11,652,451 in the State Local Agency Investment Fund Pool (LAIF) with a YTM of .24%.

In accordance with California Government Code Section 53646, the City is properly reporting investments of all bond proceeds and Deferred Compensation Plan funds. These funds are not managed by the City Treasurer as part of the pooled investment program and were not included in the City's investment reports prior to the current legislation. Bond proceeds are held and invested by a Trustee; Deferred Compensation Plan funds are held and invested by the respective plan administrators with the funds also placed in a trust separate from City funds.

FISCAL IMPACT

Current market rates continue to hover at or near all-time lows and based on comments by the Federal Reserve Board we do not expect this to change in the near future. This interest rate environment directly impacts the ability of the portfolio to generate income. The budget for fiscal year 2012-13 projected General Fund investment earnings totaling \$2.3 million. Year to date through June 2013 these revenues have totaled \$ 2.1 million which is in line with the projections for FY 2013 which were included in the FY 2013-14 budget.

CITY COUNCIL GOALS

Revenue Diversification and Preservation. Develop a variety of City revenue sources and policies to create a stable revenue base and fiscal policies to support essential City services, regardless of economic climate.

SUMMARY

The attached Quarterly Investment Report presents the City’s cash and investments for the quarter that ended June 30, 2013. This report is in compliance with California Government Code Section 53646 regarding the reporting of detailed information on all securities, investments, and monies of the City, as well as the reporting of the market value of the investments held. All of the investments contained within the portfolio are in full compliance with the City’s Investment Policy and Government Code Section 53601 as to the types of investments allowed. It is recommended that the City Council receive and file the attached Quarterly Investment Report.

NOTIFICATION

Publication of the agenda

ATTACHMENTS

- Attachment 1 - Treasurer’s Cash and Investments Report – June 2013
- Attachment 2 – Chandler Asset Management Bond Market Review – July 2013

Prepared By:
Brooke McKinney
Treasury Operations Division Manager

Department Head Approval:
Richard Teichert
Chief Financial Officer

Council Action	
Approved as requested:	Referred to:
Approved as amended:	For:
Denied:	Continued until:
Other:	Hearing set for:

This page intentionally left blank.

CITY OF MORENO VALLEY
Treasurer's Cash and Investments Report

June 2013

General Portfolio	Cost Value	Market Value	Par Value	Average Maturity	Average Yield to Maturity	Average Duration
Bank Accounts	2,172,274	2,172,274	2,172,274			
State of California LAIF Pool Investments	11,652,451	11,652,451	11,652,451	0.77	0.24%	2.28
	149,572,035	148,649,769	146,817,918	2.41	1.25%	Years
Total General Portfolio	163,396,760	162,474,494	160,642,643			

Bond Proceeds with Fiscal Agents	Market Value
Construction Funds	2,056,901
Principal & Interest Accounts	642,733
Debt Service Reserve Funds	6,398,041
Custody Accounts	0
Arbitrage Rebate Accounts	0
Other Accounts	241,544
Total Bond Proceeds	9,339,219

Deferred Compensation Funds	Market Value as of June 30, 2013
Nationwide	10,713,851
ICMA	4,743,306
Total Deferred Compensation Funds	15,457,157

Total Investment Portfolio
187,270,870

1. I hereby certify that the investments are in compliance with the investment policy adopted by the City Council. There are no items of non-compliance for this period.
2. The market values for the specific investments in the General Portfolio are provided by the City's investment advisor, Chandler Asset Management.
3. The market value for LAIF is provided by the State Treasurer.
4. The market values for investments held by fiscal agents and the deferred compensation plans are provided by each respective trustee or fiscal agent.
5. The City has the ability to meet its budgeted expenditures for the next six months pending any future action by City Council or any unforeseen catastrophic event.

 Richard Teichert
 City Treasurer



PORTFOLIO CHARACTERISTICS

Average Duration	2.28
Average Coupon	1.70 %
Average Purchase YTM	1.25 %
Average Market YTM	0.79 %
Average S&P/Moody Rating	AA/Aa1
Average Final Maturity	2.41 yrs
Average Life	2.33 yrs

ACCOUNT SUMMARY

Market Value	Beg. Values as of 5/31/13	End Values as of 6/30/13
Accrued Interest	172,496,458	162,474,494
Total Market Value	173,165,375	163,171,830
Income Earned	165,638	172,539
Cont/W/D	169,622,945	160,642,643
Par	170,705,588	161,600,328
Book Value	172,444,997	163,396,760
Cost Value		

TOP ISSUERS

Issuer	% Portfolio
Government of United States	17.1 %
Federal Home Loan Mortgage Corp	10.6 %
Federal National Mortgage Assoc	10.1 %
Federal Farm Credit Bank	9.3 %
Federal Home Loan Bank	8.8 %
Local Agency Investment Fund	7.1 %
JP Morgan Chase & Co	2.7 %
Tennessee Valley Authority	2.4 %
	68.1 %

SECTOR ALLOCATION

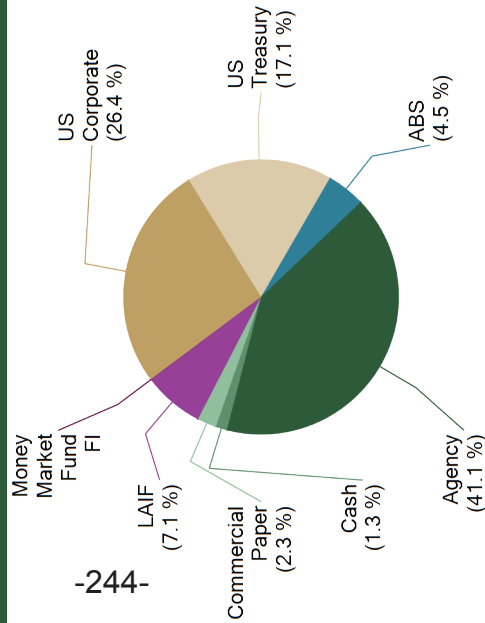

MATURITY DISTRIBUTION

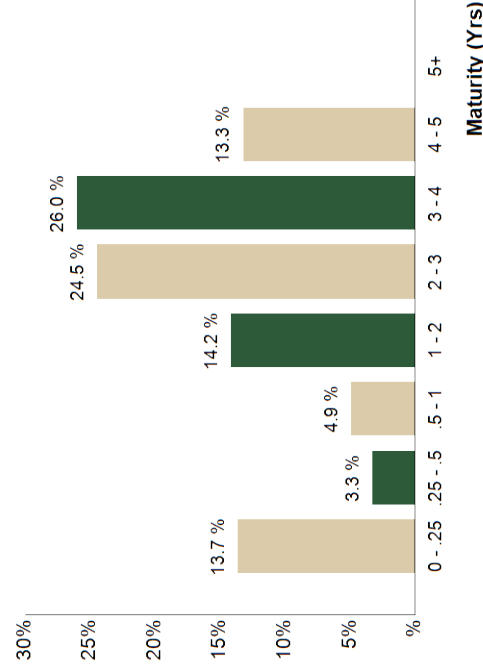

CREDIT QUALITY (S&P)

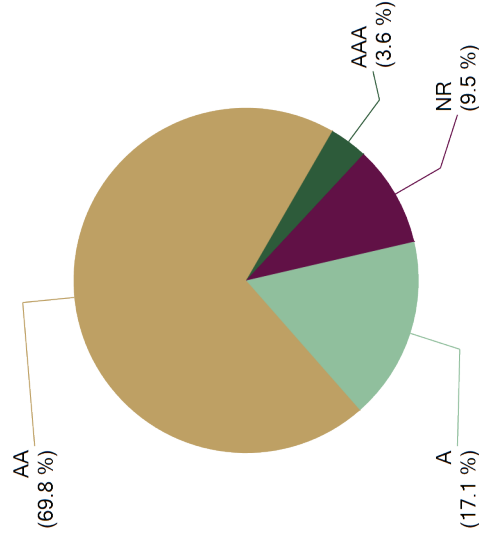



**City of Moreno Valley
Treasurer's Cash and Investments Report**

Holdings Report

As of 6/30/13

CUSIP	Security Description	Par Value/Units	Purchase Date Book Yield	Cost Value Book Value	Mkt Price Mkt YTM	Market Value Accrued Int.	% of Port. Gain/Loss	Moody S&P	Maturity Duration
47787RAC4	John Deere Owner Trust 2012-B A3 0.53% Due 7/15/2016	1,625,000.00	08/28/2012 0.53 %	1,624,949.79 1,624,960.44	99.70 0.76 %	1,620,108.75 382.78	0.99 % (4,851.69)	Aaa NR	3.04 1.32
89231NAC7	Toyota Auto Receivable 2012-B A3 0.46% Due 7/15/2016	1,620,000.00	09/18/2012 0.46 %	1,619,845.94 1,619,885.45	99.70 0.65 %	1,615,156.20 331.20	0.99 % (4,729.25)	Aaa AAA	3.04 1.60
43814CAC3	Honda Auto Receivables 2013-1 A3 0.48% Due 11/21/2016	2,525,000.00	01/16/2013 0.48 %	2,524,867.44 2,524,887.40	99.51 0.72 %	2,512,602.25 336.67	1.54 % (12,285.15)	NR AAA	3.40 2.05
161571FL3	Chase CHAIT Pool #2012-A5 0.59% Due 8/15/2017	1,680,000.00	03/19/2013 0.59 %	1,680,000.00 1,680,000.00	99.54 0.81 %	1,672,322.40 385.47	1.03 % (7,677.60)	NR AAA	4.13 2.09
Total ABS		7,450,000.00	0.51 %	7,449,663.17 7,449,733.29	0.73 %	7,420,189.60 1,436.12	4.55 % (29,543.69)	Aaa AAA	3.41 1.80
AGENCY									
880591DW9	Tennessee Valley Authority Note 4.75% Due 8/1/2013	3,750,000.00	03/15/2010 1.90 %	4,097,325.00 3,758,725.34	100.36 0.54 %	3,763,563.75 74,218.75	2.35 % 4,838.41	Aaa AA+	0.09 0.09
31331KET3	FFCB Note 0.98% Due 9/23/2013	1,970,000.00	03/28/2011 1.10 %	1,964,227.90 1,969,466.02	100.19 0.15 %	1,973,766.64 5,255.52	1.21 % 4,300.62	Aaa AA+	0.23 0.23
31331JQA4	FFCB Note 1.9% Due 6/2/2014	2,850,000.00	06/08/2010 1.96 %	2,843,074.50 2,848,394.09	101.54 0.23 %	2,893,915.65 4,362.08	1.78 % 45,521.56	Aaa AA+	0.92 0.92
313316PLV7	FNMA Callable Note 1X 3/24/2011 1.57% Due 9/24/2014	2,025,000.00	09/26/2011 0.65 %	2,080,181.25 2,047,739.53	101.58 0.29 %	2,056,992.98 8,566.31	1.27 % 9,253.45	Aaa AA+	1.24 1.22
3133EADW5	FFCB Note 0.55% Due 8/17/2015	3,450,000.00	04/27/2012 0.60 %	3,444,862.95 3,446,684.81	99.80 0.64 %	3,443,200.05 7,062.92	2.11 % (3,484.76)	Aaa AA+	2.13 2.11
313370JB5	FHLB Note 1.75% Due 9/11/2015	1,200,000.00	08/04/2011 1.15 %	1,228,608.00 1,215,316.17	102.76 0.49 %	1,233,074.40 6,416.67	0.76 % 17,758.23	Aaa AA+	2.20 2.15
3133ECBJ2	FFCB Note 0.43% Due 11/16/2015	3,100,000.00	12/24/2012 0.45 %	3,098,233.00 3,098,544.82	99.55 0.62 %	3,085,907.40 1,666.25	1.89 % (12,637.42)	Aaa AA+	2.38 2.36
31331J6C2	FFCB Note 2.35% Due 12/22/2015	2,000,000.00	03/28/2011 2.27 %	2,007,240.00 2,003,785.40	104.18 0.65 %	2,083,610.00 1,175.00	1.28 % 79,824.60	Aaa AA+	2.48 2.41
3138FPDC8	FNMA Callable Note 1X 3/8/2011 2% Due 3/8/2016	1,765,000.00	08/24/2011 1.22 %	1,825,645.40 1,800,904.13	103.54 0.67 %	1,827,466.88 11,080.28	1.13 % 26,562.75	Aaa AA+	2.69 2.61
313372YS7	FHLB Note 2.45% Due 3/30/2016	2,150,000.00	07/07/2011 1.87 %	2,206,631.00 2,182,889.92	104.68 0.73 %	2,250,609.25 13,315.07	1.39 % 67,719.33	Aaa AA+	2.75 2.65
3137EACT4	FHLMC Note 2.5% Due 5/27/2016	1,200,000.00	06/14/2011 1.86 %	1,235,992.80 1,221,145.27	105.01 0.76 %	1,260,102.00 2,833.33	0.77 % 38,956.73	Aaa AA+	2.91 2.81
73SZ6	FHLB Note 2.125% Due 6/10/2016	3,350,000.00	Various 1.42 %	3,456,779.50 3,416,586.72	104.01 0.75 %	3,484,217.75 4,152.61	2.14 % 67,631.03	Aaa AA+	2.95 2.86
EACW7	FHLMC Note 2% Due 8/25/2016	3,475,000.00	09/14/2011 1.19 %	3,610,316.50 3,561,239.92	103.60 0.84 %	3,600,065.25 24,325.00	2.22 % 38,825.33	Aaa AA+	3.16 3.04
G0ES8	FNMA Note 1.375% Due 11/15/2016	2,900,000.00	01/24/2012 1.17 %	2,927,196.20 2,919,117.97	101.37 0.96 %	2,939,863.40 5,095.14	1.80 % 20,745.43	Aaa AA+	3.38 3.29

Item No. A.8

P	Security Description	Par Value/Units	Purchase Date Book Yield	Cost Value Book Value	Mkt Price Mkt YTM	Market Value Accrued Int.	% of Port. Gain/Loss	Moody S&P	Maturity Duration
NCY									
G0GY3	FNMA Note 1.25% Due 1/30/2017	3,425,000.00	02/09/2012 1.10 %	3,449,368.88 3,442,604.23	100.61 1.08 %	3,445,961.00 17,957.47	2.12 % 3,356.77	Aaa AA+	3.59 3.48
787M7	FHLB Note 1.05% Due 2/27/2017	1,720,000.00	02/27/2012 1.03 %	1,721,582.40 1,721,158.64	99.22 1.27 %	1,706,649.36 6,220.67	1.05 % (14,509.28)	Aaa AA+	3.67 3.56
3135G0UY7	FNMA Callable Note 1X 02/27/15 1% Due 2/27/2017	1,500,000.00	04/23/2013 0.48 %	1,514,250.00 1,512,812.31	99.53 1.13 %	1,492,981.50 5,166.67	0.92 % (19,830.81)	Aaa AA+	3.67 3.57
3137EADC0	FHLMC Note 1% Due 3/8/2017	3,490,000.00	03/14/2012 1.29 %	3,441,314.50 3,453,974.34	99.51 1.14 %	3,472,899.00 10,954.72	2.14 % 18,924.66	Aaa AA+	3.69 3.60
313378WF4	FHLB Note 1.125% Due 3/10/2017	3,435,000.00	04/24/2012 1.05 %	3,447,228.60 3,444,260.76	99.96 1.14 %	3,433,708.44 11,915.16	2.11 % (10,552.32)	Aaa AA+	3.70 3.60
3133782N0	FHLB Note 0.875% Due 3/10/2017	1,310,000.00	03/13/2013 0.70 %	1,318,894.90 1,318,235.11	99.06 1.14 %	1,297,700.41 3,534.27	0.80 % (20,534.70)	Aaa AA+	3.70 3.61
3137EADF3	FHLMC Note 1.25% Due 5/12/2017	3,300,000.00	05/29/2012 1.06 %	3,330,600.90 3,323,881.57	100.14 1.21 %	3,304,610.10 5,614.58	2.03 % (19,271.47)	Aaa AA+	3.87 3.76
313379VE6	FHLB Note 1.01% Due 6/19/2017	915,000.00	07/26/2012 0.82 %	923,363.10 921,777.48	98.90 1.30 %	904,923.11 308.05	0.55 % (16,854.37)	Aaa AA+	3.97 3.87
3137EADH9	FHLMC Note 1% Due 6/29/2017	3,150,000.00	Various 0.85 %	3,171,475.20 3,167,849.16	99.10 1.23 %	3,121,741.36 175.00	1.91 % (46,107.80)	Aaa AA+	4.00 3.90
3EAY28	FFCB Note 0.83% Due 9/21/2017	1,645,000.00	09/18/2012 0.83 %	1,645,000.00 1,645,000.00	97.73 1.38 %	1,607,712.79 3,792.64	0.99 % (37,287.21)	Aaa AA+	4.23 4.12
3137EADL0	FHLMC Note 1% Due 9/29/2017	1,050,000.00	10/25/2012 0.92 %	1,053,983.70 1,053,442.18	98.81 1.29 %	1,037,503.95 2,683.33	0.64 % (15,938.23)	Aaa AA+	4.25 4.13
3135G0RT2	FNMA Note 0.875% Due 12/20/2017	1,850,000.00	02/22/2013 0.93 %	1,845,264.00 1,845,603.25	97.42 1.47 %	1,802,223.75 494.62	1.10 % (43,379.50)	Aaa AA+	4.48 4.36
3137EADN6	FHLMC Note 0.75% Due 1/12/2018	1,500,000.00	05/10/2013 0.88 %	1,491,378.00 1,491,625.79	96.82 1.48 %	1,452,312.00 5,281.25	0.89 % (39,313.79)	Aaa AA+	4.54 4.42
3135G0TG8	FNMA Note 0.875% Due 2/8/2018	2,950,000.00	Various 1.33 %	2,889,437.30 2,889,868.93	97.09 1.53 %	2,864,110.75 10,253.30	1.76 % (25,758.18)	Aaa AA+	4.61 4.47
Total Agency		66,425,000.00	1.17 %	67,269,455.48 66,722,633.86	0.91 %	66,841,392.92 253,876.66	41.12 % 118,759.06	Aaa AA+	2.95 2.87
CASH									
90CASH\$00	Cash Custodial Cash Account	2,172,273.72	Various 0.00 %	2,172,273.72 2,172,273.72	1.00 0.00 %	2,172,273.72 0.00	1.33 % 0.00	NR NR	0.00 0.00
Total Cash		2,172,273.72	N/A	2,172,273.72 2,172,273.72	0.00 %	2,172,273.72 0.00	1.33 % 0.00	NR NR	0.00 0.00
COMMERCIAL PAPER									
06538BXF5	Bank of Tokyo Mitsubishi NY Discount CP 0.23% Due 10/15/2013	3,015,000.00	06/12/2013 0.23 %	3,012,611.46 3,012,958.18	99.93 0.23 %	3,012,958.18 0.00	1.85 % 0.00	P-1 A-1	0.29 0.29



City of Moreno Valley
Treasurer's Cash and Investments Report

Holdings Report

As of 6/30/13

CUSIP	Security Description	Par Value/Units	Purchase Date Book Yield	Cost Value Book Value	Mkt Price Mkt YTM	Market Value Accrued Int.	% of Port. Gain/Loss	Moody S&P	Maturity Duration
COMMERCIAL PAPER									
06416JZG1	Bank of Nova Scotia Discount CP 0.22% Due 12/16/2013	660,000.00	05/14/2013 0.22 %	659,132.83 659,322.40	99.90 0.22 %	659,322.40 0.00	0.40 % 0.00	P-1 A-1	0.46 0.46
	Total Commercial Paper	3,675,000.00	0.23 %	3,671,744.29 3,672,280.58	0.23 %	3,672,280.58 0.00	2.25 % 0.00	P1 A-1	0.32 0.32
LAIF									
90LAIF\$00	Local Agency Investment Fund State Pool	11,652,450.84	Various 0.24 %	11,652,450.84 11,652,450.84	1.00 0.24 %	11,652,450.84 7,751.01	7.15 % 0.00	NR NR	0.00 0.00
	Total LAIF	11,652,450.84	0.24 %	11,652,450.84 11,652,450.84	0.24 %	11,652,450.84 7,751.01	7.15 % 0.00	NR NR	0.00 0.00
MONEY MARKET FUND FI									
431114701	Highmark Govt Money Market Fund	47,918.03	Various 0.00 %	47,918.03 47,918.03	1.00 0.00 %	47,918.03 0.00	0.03 % 0.00	Aaa AAA	0.00 0.00
	Total Money Market Fund FI	47,918.03	0.00 %	47,918.03 47,918.03	0.00 %	47,918.03 0.00	0.03 % 0.00	Aaa AAA	0.00 0.00
CORPORATE									
254687AW6	US Bancorp Callable Note Cont 1.375% Due 9/13/2013	2,665,000.00	Various 1.32 %	2,668,966.65 2,665,125.35	100.12 0.37 %	2,668,203.33 10,993.13	1.64 % 3,077.98	A1 A+	0.21 0.12
665859AK0	Walt Disney Corp Note 4.5% Due 12/15/2013	1,720,000.00	Various 1.23 %	1,873,880.60 1,745,175.67	101.81 0.54 %	1,751,101.04 3,440.00	1.08 % 5,925.37	A2 A	0.46 0.46
36962G4C5	Northern Trust Company Note 4.625% Due 5/1/2014	1,850,000.00	10/20/2010 1.33 %	2,058,421.00 1,899,345.78	103.44 0.50 %	1,913,630.75 14,260.42	1.18 % 14,284.97	A1 A+	0.84 0.82
74005PAQ7	General Electric Capital Corp Note 5.9% Due 5/13/2014	3,075,000.00	Various 2.88 %	3,411,681.00 3,150,487.47	104.72 0.45 %	3,220,201.50 24,190.00	1.99 % 69,714.03	A1 AA+	0.87 0.85
09247XAD3	Praxair Note 5.25% Due 11/15/2014	850,000.00	09/24/2010 1.60 %	973,471.00 891,102.42	106.32 0.63 %	903,684.30 5,702.08	0.56 % 12,581.88	A2 A	1.38 1.33
713448BM9	Blackrock Inc Note 3.5% Due 12/10/2014	1,630,000.00	Various 2.84 %	1,674,920.75 1,644,408.51	104.03 0.69 %	1,695,762.35 3,327.92	1.04 % 51,353.84	A1 A+	1.45 1.41
0005HHP8	Pepsico Inc. Note 3.1% Due 1/15/2015	2,530,000.00	Various 2.04 %	2,641,540.25 2,569,232.94	103.74 0.66 %	2,624,725.74 36,164.95	1.63 % 55,492.80	A1 A-	1.55 1.49
00HB0	JP Morgan Chase Note 3.7% Due 1/20/2015	2,550,000.00	Various 3.34 %	2,584,656.00 2,563,353.78	103.86 1.19 %	2,648,537.10 42,195.42	1.65 % 85,183.32	A2 A	1.56 1.49
0VAA6	IBM Corp Note 0.55% Due 2/6/2015	695,000.00	02/01/2012 0.72 %	691,601.45 693,185.99	99.92 0.60 %	694,426.63 1,539.62	0.43 % 1,240.64	Aa3 AA-	1.61 1.59
70AV0	Wells Fargo Bank Note 4.75% Due 2/9/2015	2,475,000.00	Various 3.65 %	2,584,316.50 2,515,082.86	105.54 1.26 %	2,612,090.25 46,371.87	1.63 % 97,007.39	A1 A+	1.61 1.53
	Berkshire Hathaway Note 3.2% Due 2/11/2015	2,485,000.00	06/09/2010 2.65 %	2,545,012.75 2,505,791.26	104.01 0.69 %	2,584,728.02 30,924.44	1.60 % 78,936.76	Aa2 AA	1.62 1.56

P	Security Description	Par Value/Units	Purchase Date Book Yield	Cost Value Book Value	Mkt Price Mkt YTM	Market Value Accrued Int.	% of Port. Gain/Loss	Moody S&P	Maturity Duration
CORPORATE									
16AX8	Coca Cola Company Note 0.75% Due 3/13/2015	2,090,000.00	Various 0.80 %	2,086,645.55 2,088,096.67	100.35 0.54 %	2,097,315.00 4,702.50	1.29 % 9,218.33	Aa3 AA-	1.70 1.69
6JHB4	Bank of New York Mellon Note 4.95% Due 3/15/2015	2,360,000.00	Various 2.11 %	2,645,950.90 2,468,220.96	106.85 0.90 %	2,521,601.01 34,397.01	1.57 % 53,380.05	A1 A	1.71 1.63
717081DA8	Pfizer Inc. Note 5.35% Due 3/15/2015	1,550,000.00	02/18/2011 2.33 %	1,730,497.50 1,625,857.73	107.68 0.81 %	1,669,040.00 24,416.81	1.04 % 43,182.27	A1 AA	1.71 1.63
74005PAR5	Praxair Note 4.625% Due 3/30/2015	740,000.00	Various 2.58 %	807,780.55 764,737.25	106.78 0.72 %	790,156.47 8,651.32	0.49 % 25,419.22	A2 A	1.75 1.68
278642AB9	Ebay Inc Note 1.625% Due 10/15/2015	2,670,000.00	10/22/2010 1.66 %	2,665,327.50 2,667,845.44	102.13 0.69 %	2,726,929.74 9,159.58	1.68 % 59,084.30	A2 A	2.29 2.24
38259PAC6	Google Inc Note 2.125% Due 5/19/2016	1,315,000.00	11/15/2012 0.75 %	1,377,186.90 1,366,318.81	103.34 0.95 %	1,358,970.97 3,260.10	0.83 % (7,347.84)	Aa2 AA	2.89 2.80
24422ERL5	John Deere Capital Corp Note 2% Due 1/13/2017	1,215,000.00	09/11/2012 1.05 %	1,263,733.65 1,254,800.17	101.15 1.66 %	1,228,984.65 11,340.00	0.76 % (25,815.52)	A2 A	3.54 3.37
674599CB9	Occidental Petroleum Note 1.75% Due 2/15/2017	1,575,000.00	03/08/2013 1.13 %	1,612,532.25 1,609,655.21	99.92 1.77 %	1,573,744.73 10,412.50	0.97 % (35,910.48)	A1 A	3.63 3.47
913017BU2	United Tech Corp Note 1.8% Due 6/1/2017	170,000.00	05/24/2012 1.82 %	169,853.80 169,885.43	100.37 1.70 %	170,622.71 255.00	0.10 % 737.28	A2 A	3.92 3.76
24 764AA8	Chevron Corp. Callable Note Cont 11/5/17 1.104% Due 12/5/2017	550,000.00	11/28/2012 1.10 %	550,000.00 550,000.00	97.71 1.64 %	537,411.60 438.53	0.33 % (12,588.40)	Aa1 AA	4.44 4.30
458140AL4	Intel Corp Note 1.35% Due 12/15/2017	1,940,000.00	12/12/2012 1.29 %	1,945,790.55 1,945,168.32	97.86 1.85 %	1,898,524.75 1,164.00	1.16 % (46,643.57)	A1 A+	4.46 4.30
931142DF7	Wal-Mart Stores Note 1.125% Due 4/11/2018	1,130,000.00	04/04/2013 1.14 %	1,128,960.40 1,129,006.52	97.05 1.77 %	1,096,645.79 2,825.00	0.67 % (32,360.73)	Aa2 AA	4.78 4.61
037833AJ9	Apple Inc Note 1% Due 5/3/2018	1,900,000.00	05/22/2013 1.25 %	1,877,181.00 1,877,611.79	96.03 1.86 %	1,824,566.20 3,061.11	1.12 % (53,045.59)	Aa1 AA+	4.84 4.68
Total US Corporate		41,730,000.00	1.93 %	43,569,908.50 42,359,496.33	0.93 %	42,811,604.63 333,193.31	26.44 % 452,108.30	A1 A+	1.99 1.91
US TREASURY									
912828NP1	US Treasury Note 1.75% Due 7/31/2015	3,050,000.00	04/06/2011 1.99 %	3,019,391.07 3,035,239.35	102.83 0.39 %	3,136,257.05 22,264.16	1.94 % 101,017.70	Aaa AA+	2.08 2.04
912828PE4	US Treasury Note 1.25% Due 10/31/2015	3,025,000.00	Various 1.35 %	3,012,297.25 3,018,268.97	101.84 0.45 %	3,080,774.95 6,370.58	1.89 % 62,505.98	Aaa AA+	2.34 2.30
912828PJ3	US Treasury Note 1.375% Due 11/30/2015	3,590,000.00	05/16/2011 1.63 %	3,549,905.00 3,568,645.05	102.13 0.49 %	3,666,287.50 4,180.98	2.25 % 97,642.45	Aaa AA+	2.42 2.38
912828PS3	US Treasury Note 2% Due 1/31/2016	3,505,000.00	05/16/2011 1.70 %	3,551,973.24 3,530,810.67	103.77 0.53 %	3,637,257.67 29,240.61	2.25 % 106,447.00	Aaa AA+	2.59 2.51
912828QA1	US Treasury Note 2.25% Due 3/31/2016	3,435,000.00	Various 1.33 %	3,578,212.10 3,518,470.20	104.51 0.60 %	3,589,842.93 19,427.45	2.21 % 71,372.73	Aaa AA+	2.75 2.66



CUSIP	Security Description	Par Value/Units	Purchase Date Book Yield	Cost Value Book Value	Mkt Price Mkt YTM	Market Value Accrued Int.	% of Port. Gain/Loss	Moody S&P	Maturity Duration
US TREASURY									
912828RU6	US Treasury Note 0.875% Due 11/30/2016	3,200,000.00	12/22/2011 0.89 %	3,198,135.71 3,198,707.43	100.06 0.86 %	3,202,000.00 2,371.58	1.96 % 3,292.57	Aaa AA+	3.42 3.36
912828SC5	US Treasury Note 0.875% Due 1/31/2017	1,710,000.00	06/20/2012 0.70 %	1,723,298.31 1,720,338.75	99.84 0.92 %	1,707,328.98 6,241.26	1.05 % (13,009.77)	Aaa AA+	3.59 3.51
912828TG5	US Treasury Note 0.5% Due 7/31/2017	3,100,000.00	02/25/2013 0.73 %	3,069,373.67 3,071,742.66	97.60 1.10 %	3,025,649.60 6,465.47	1.86 % (46,093.06)	Aaa AA+	4.09 4.02
912828TS9	US Treasury Note 0.625% Due 9/30/2017	2,875,000.00	Various 0.74 %	2,860,759.64 2,861,318.37	97.77 1.16 %	2,810,985.25 4,516.74	1.73 % (50,333.12)	Aaa AA+	4.25 4.17
Total US Treasury		27,490,000.00	1.27 %	27,563,345.99 27,523,541.45	0.70 %	27,856,383.93 101,078.83	17.13 % 332,842.48	Aaa AA+	2.99 2.92
TOTAL PORTFOLIO									
		160,642,642.59	1.25 %	163,396,760.02 161,600,328.10	0.79 %	162,474,494.25 697,335.93	100.00 % 874,166.15	Aa1 AA	2.41 2.28
TOTAL MARKET VALUE PLUS ACCRUED						163,171,830.18			



COMPLIANCE WITH INVESTMENT POLICY

Assets managed by Chandler Asset Management are in full compliance with State law and with the City's investment policy.

Category	Standard	Comment
Local Agency Bonds	No Limitation	Complies
Treasury Issues	No Limitation	Complies
Agency Issues	No Limitation	Complies
Banker's Acceptances	40% maximum; <180 days maturity	Complies
Commercial Paper	25% maximum; <270 days maturity; A-1/P-1/F-1 minimum ratings	Complies
Negotiable Certificates of Deposit	30% maximum; 5 years maximum maturity	Complies
Repurchase Agreements	No limitation; 1-year maximum maturity	Complies
Reverse Repurchase Agreements	20% maximum; <92 days maturity	Complies
Medium Term Notes	30% maximum; 5 years maximum maturity; A-rated or better	Complies
Money Market Mutual Funds	20% maximum; AAAf/Aaaf, minimum rating	Complies
Collateralized Certificates of Deposits	5 years maximum maturity	Complies
Time Deposits	5 years maximum maturity	Complies
Mortgage Pass-throughs, CMOs and Asset Backed Securities	20% maximum; AA-rated issue; A-rated issuer	Complies
Local Agency Investment Fund - L.A.I.F.	Maximum program limitation	Complies
Prohibited Securities	Inverse floaters; Ranges notes, Interest-only strips from mortgaged backed securities; Zero interest accrual securities	Complies
Maximum maturity	5 years	Complies
Weighted Average Maturity	3 years	Complies



Holdings Report Glossary

CUSIP (Committee on Uniform Securities Identification Procedures) – A unique identification number assigned to all securities.

Security Description - The issuer name, coupon (periodic interest payment rate) and maturity.

Par Value/Units - The face value or number of units held in the portfolio.

Purchase Date - The settlement date on which the security was purchased.

Book Yield - The YTM that equates the current amortized value of the security to its periodic future cash flows.

Cost Value - The value at which the securities were purchased, excluding purchased interest.

Book Value - The value at which an asset is carried on a balance sheet. To calculate, take the cost of an asset +/- net creation/amortization.

Mkt Price - The current fair value market price.

Mkt YTM – The internal rate of return that equates the periodic future cash flows (interest payments and redemption value) to the market price, assuming that all cash flows are invested at the YTM rate.

Market Value - The current fair value of an investment as determined by transactions between willing buyers and sellers.

Accrued Int. - The interest that has accumulated on a bond since the last interest payment up to, but not including, the settlement date.

Item of Port. - The % of the portfolio that the security represents based on market value, including accrued interest.

In/Loss – The unrealized gain or loss on the security, compared to either cost or amortized value, as of the date of the report.

Moody - The Moody's rating for the security.



Item No. **A.8** | Holdings Report Glossary (continued)

P - The Standard and Poor's rating for the security.

Term (yrs) - The time, in years, until maturity.

Duration - The weighted average time to maturity of a bond where the weights are the present values of future cash flows. Duration measures the price sensitivity of a bond to changes in interest rates.

BOND PROCEEDS WITH FISCAL AGENTS

Account Name	Account Number	Investment	Issuer	Purchase Date	Maturity Date	Market Value	Stated Rate	Yield	Price	% of Portfolio
Wells Fargo <u>Community Facilities District 87-1 (IA-1)</u>										
special tax funds	22631800	money market fund	WF Govt Fund	06/30/13	07/01/13	1,044,451	0.01%	0.01%	1.00000	11.183%
interest acct	22631801	money market fund	WF Govt Fund	06/30/13	07/01/13	0	0.01%	0.01%	1.00000	0.000%
reserve fund	22631804	money market fund	WF Govt Fund	06/30/13	07/01/13	1,028,690	0.01%	0.01%	1.00000	11.015%
admin exp acct	22631805	money market fund	WF Govt Fund	06/30/13	07/01/13	377	0.01%	0.01%	1.00000	0.004%
debt service acct	22631809	money market fund	WF Govt Fund	06/30/13	07/01/13	536,000	0.01%	0.01%	1.00000	5.739%
special tax funds	22631900	money market fund	WF Govt Fund	06/30/13	07/01/13	389,532	0.01%	0.01%	1.00000	4.171%
reserve fund	22631904	money market fund	WF Govt Fund	06/30/13	07/01/13	365,379	0.01%	0.01%	1.00000	3.912%
admin exp acct	22631905	money market fund	WF Govt Fund	06/30/13	07/01/13	15,865	0.01%	0.01%	1.00000	0.170%
						3,380,294				
Wells Fargo <u>CFD # 5</u>										
Series B Revenue	22333500	money mkt fund	WF Govt Fund	06/30/13	07/01/13	193,857	0.01%	0.01%	1.00000	2.076%
Series A Principal	22333501	money mkt fund	WF Govt Fund	06/30/13	07/01/13	0	0.01%	2.71%	1.00000	0.000%
Series B reserve	22333503	money mkt fund	WF Govt Fund	06/30/13	07/01/13	543,212	0.01%	0.01%	1.00000	5.816%
Series B admin fund	22333504	money mkt fund	WF Govt Fund	06/30/13	07/01/13	26,743	0.01%	0.01%	1.00000	0.286%
						763,812				
Wells Fargo <u>2007 Redevelopment Agency Tax Allocation Bonds Series A</u>										
debt service fund	22631700	money mkt fund	WF Govt Fund	06/30/13	07/01/13	0	0.01%	0.01%	1.00000	0.000%
						0				
Wells Fargo <u>2005 Lease Revenue Bond</u>										
bond fund	18042800	money mkt fund	WF Govt Fund	06/30/13	07/01/13	3	0.01%	0.01%	1.00000	0.000%
reserve fund	18042804	money mkt fund	WF Govt Fund	06/30/13	07/01/13	2,992,753	0.01%	0.01%	1.00000	32.045%
construction fund	18042806	money mkt fund	WF Govt Fund	06/30/13	07/01/13	8	0.01%	0.01%	1.00000	0.000%
						2,992,764				32.045%
Wells Fargo <u>2007 Taxable Lease Revenue Bonds - Electric Utility</u>										
bond fund	22277600	money mkt fund	WF Govt Fund	06/30/13	07/01/13	4	0.01%	0.01%	1.00000	0.000%
construction fund	22277604	money mkt fund	WF Govt Fund	06/30/13	07/01/13	2,056,893	0.01%	0.01%	1.00000	22.024%
						2,056,897				
Wells Fargo <u>Automal Refinancing</u>										
revenue fund	20350300	revenue	WF Govt Fund	06/30/13	07/01/13	79,987	0.01%	0.01%	1.00000	0.856%
reserve fund	20350303	reserve	WF Govt Fund	06/30/13	07/01/13	34,020	0.01%	0.01%	1.00000	0.364%
admin fund	20350304	reserve	WF Govt Fund	06/30/13	07/01/13	31,445	0.01%	0.01%	1.00000	0.337%
						145,452				1.557%
						9,339,219				100.000%
			Totals							
Summary of Bond Proceeds with Fiscal Agents										
<u>Type</u>										
1		Construction Funds				2,056,901				
2		Principal & Interest Accounts				642,733				
3		Debt Service Reserve Funds				6,398,041				
4		Custody Accounts				0				
5		Arbitrage Rebate Accounts				0				
6		Other Accounts				241,544				
		Total Fiscal Agent Funds				9,339,219				

DEFERRED COMPENSATION FUNDS

Nationwide

Fund	Market Value as of June 30, 2013	Fund	Market Value as of June 30, 2013
Liquid Savings	\$1,199,180	Drey SmCap I	0
Nationwide Fixed (Part Time Employee)	457,908	American Century Balanced	36
Liquid Savings (Part Time Employees)	290,674	Am Century Growth	61,321
Certificates of Deposit 1 year	30,085	Am Century Select	114,016
Certificates of Deposit 3 years	21,705	JF Morgan Mid Cap Value A	850,568
Certificates of Deposit 5 years	77,845	Vanguard Index 500	103,057
Bond Fund of America	66,551	Vanguard Institutional Index	526,423
Growth Fund of America	97,368	Vanguard Wellington	18,823
Investment Co. of America	34,527	Vanguard Windsor II	63,695
Income Fund of America	146,611	Vanguard Total Bond Index	212,271
Brown Cap Mgmt Inc SM Co	53,027	Washington Mutual Inv	78,578
Fidelity Independence	1,992	Templeton Foreign I	0
Fidelity Equity Income	53,243	EuroPacific Growth	303,115
Fidelity Magellan	233,923	Stable Fund C	2,437,100
Fidelity Puritan	99,583	PBHG Growth Fund	0
Fidelity Contrafund	260,740	DWS High Income Fund A	67,352
Janus Fund	39,458	DWS Eq Divd A	85,840
Janus Advisor Forty	49,400	Oppenheimer Global Fund A	297,225

ICMA

Fund	Market Value as of June 30, 2013	Fund	Market Value as of June 30, 2013
Aggressive Oppor. International	\$241,724	VT Royce Premier	4,422
All Equity Growth	214,357	VT Ranier Small/Mid Cap Eq	42,770
Growth and Income	152,141	VT Fidelity Contrafund	168,056
Broad Market	248,074	VT Vantagepoint Overseas Equity Index Fund	85,421
500 Stock Index	78,544	VT Fidelity Diversified International	87,331
Equity Income	120,771	VT Allianz NFI Div Value	76,848
Asset Allocation	401,343	Vantage Growth Fund	257,782
Core Bond	24,458	VT Fidelity Puritan	6,556
Cash Management	22,148	VT Royce Value Plus	702
Plus Fund	994,704	VT TR Price Growth Stock Adv	19,805
Savings Oriented		VT Nuveen Real Estate Secs	62,060
Conservative Growth	169,651	VT TR Price Small Cap Value	135,854
Traditional Growth	244,208	VT Vantagepoint MS Ret Inc	32,883
Long-Term Growth	395,724	VT Vantagepoint Inflation Protected Securities	74,379
Milestone 2010	23,165	VT Oppenheimer Main Street	4,896
Milestone 2015	898	VT Vantagepoint Mid/Sm Index	28,056
Milestone 2020	51,508	VT PIMCO Total Return	112,676
Milestone 2025	27,550	VT PIMCO High Yield	61,495
Milestone 2030	16,257	VT Harbour International Admi	21,996
Milestone 2035	19,088	VT Harbour Mid Cap Growth Admin	5,381
Milestone 2040	7,624	Total ICMA	\$4,743,306

Summary by Plan

Deferred Compensation Plan	Market Value as of June 30, 2013
Total Nationwide	\$10,713,851
Total ICMA	4,743,306
Total Deferred Compensation Plans	\$15,457,157

Summary by Investment Type

Investment Type	Market Value as of June 30, 2013
Savings Deposits and CD's	\$4,436,652
Mutual Funds	11,020,505
Total Deferred Compensation Plans	\$15,457,157

BOND MARKET REVIEW

A MONTHLY REVIEW OF
FIXED INCOME MARKETS



WHAT'S INSIDE

Market Summary 1
Yield Curve
Current Yields

Economic Round-Up 2
Credit Spreads
Economic Indicators

Slowing Growth In China. . . . 3
And What It Means For The
Global Economy

Since 1988, Chandler Asset Management has specialized in the management of fixed income portfolios. Chandler's mission is to provide fully customizable, client-centered portfolio management that preserves principal, manages risk and generates income in our clients' portfolios.

Market Summary

The economy continues to grow slowly. Nonfarm payrolls rose 195,000 in June, which was better than the consensus forecast of 161,000. Average nonfarm payroll growth during the second quarter of 2013 was about 196,000 per month. The unemployment rate remained unchanged in June at 7.6% due to an increase in the labor force. Overall, the labor market continues to improve. Manufacturing trends are beginning to show modest improvement as well, while housing trends remain favorable in spite of the recent jump in interest rates. Consumer spending also remains healthy.

The Treasury yield curve steepened again in June as Fed policymakers continued to discuss winding down quantitative easing. The move has also been influenced by a modest improvement in economic data.

The Federal Open Market Committee left policy rates unchanged at its June 18-19 meeting and assured investors that policy changes continue to be data dependent. The Fed noted that the economy continues to grow at a moderate pace. The labor market has continued to improve, but unemployment remains elevated. Inflation is running below target. The Fed will continue to purchase mortgage-backed securities at a pace of \$40 billion per month and longer-term Treasury securities at a pace of \$45 billion per month. During his press conference, Chairman Bernanke indicated that the Fed could begin tapering bond purchases later this year and that asset purchases could end in 2014. However, he emphasized that Fed policy will depend on the state of the economy.

TREASURY YIELD CURVE STEEPENED IN JUNE

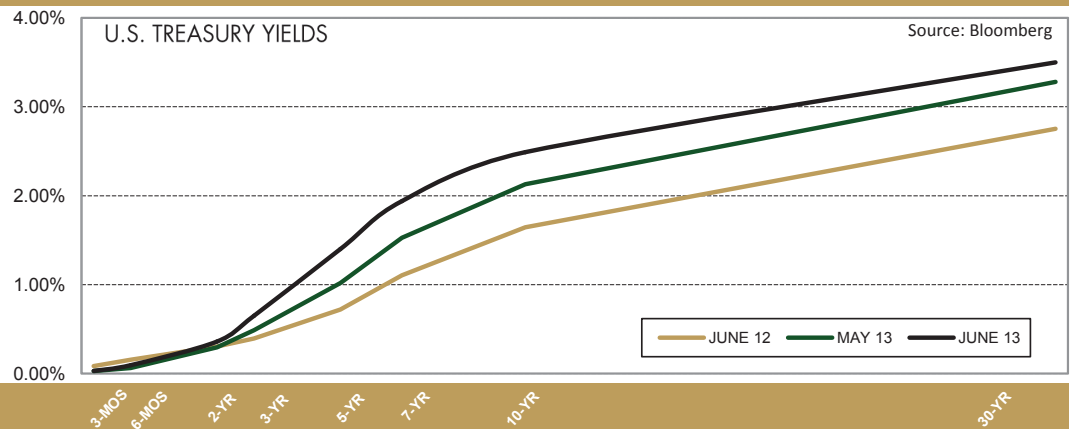

The yield curve steepened in June as economic data improved modestly and Fed policymakers continued to discuss winding down quantitative easing.

TREASURY YIELDS	6/30/2013	5/31/2013	CHANGE
3 Month	0.03	0.03	0.00
2 Year	0.36	0.30	0.06
3 Year	0.65	0.49	0.16
5 Year	1.40	1.02	0.38
7 Year	1.94	1.53	0.41
10 Year	2.49	2.13	0.36
30 Year	3.50	3.28	0.22

Source: Bloomberg

Economic Roundup

Consumer Prices

In May, overall CPI inflation rose to 1.4% on a year-over-year basis from 1.1% in April. The year-over-year Core CPI (CPI less food and energy) was unchanged at 1.7%. The core inflation rate is trending below the Fed's long-term goal of 2.0% and remains below the trigger rate for policy action of 2.5%.

Retail Sales

In May, Retail Sales rose 4.3% on a year-over-year basis. On a month-over-month basis, Retail Sales increased 0.6% in May, which was slightly better than expected. Overall, recent consumer spending trends have been favorable.

Labor Markets

The June employment report showed that payrolls increased by 195,000 (better than the 161,000 consensus estimate). The net revisions for job growth in April and May were +70,000. Average nonfarm payroll growth over the past 3 months has been about 196,000. Private payrolls increased 202,000 in June while government jobs fell 7,000. The unemployment rate remained unchanged at 7.6% due to an increase in the labor force. Overall, the jobs report was better than expected and job growth is showing positive momentum.

Housing Starts

Single-family housing starts rose slightly in May to 599,000 from 597,000 in April. Housing permits eased 3.1% in the month after rising 12.9% in April. Recent housing data has been mostly favorable.

Credit Spreads Widened in June

CREDIT SPREADS	Spread to Treasuries (%)	One Month Ago (%)	Change
3-month top-rated commercial paper	0.13	0.12	0.01
2-year A corporate note	0.71	0.54	0.17
5-year A corporate note	0.86	0.79	0.07
5-year Agency note	0.24	0.16	0.08

Source: Bloomberg

Data as of 6/30/13

Economic Data Remains Indicative of Slow Growth

ECONOMIC INDICATOR	Current Release	Prior Release	One Year Ago
Trade Balance	(45.0) \$Bln MAY 13	(40.1) \$Bln APR 13	(46.2) \$Bln MAY 12
GDP	1.8% MAR 13	0.4% DEC 12	2.0% MAR 12
Unemployment Rate	7.6% JUN 13	7.6% MAY 13	8.2% JUN 12
Prime Rate	3.25% JUN 13	3.25% MAY 13	3.25% JUN 12
CRB Index	275.62 JUN 13	281.85 MAY 13	284.19 JUN 12
Oil (West Texas Int.)	\$96.56 JUN 13	\$91.97 MAY 13	\$84.96 JUN 12
Consumer Price Index (y/o/y)	1.4% MAY 13	1.1% APR 13	1.7% MAY 12
Producer Price Index (y/o/y)	1.7% MAY 13	0.6% APR 13	0.6% MAY 12
Dollar/EURO	1.30 JUN 13	1.30 MAY 13	1.27 JUN 12

Source: Bloomberg

© 2013 Chandler Asset Management, Inc, An Independent Registered Investment Adviser. The information contained herein was obtained from sources we believe to be reliable, but we do not guarantee its accuracy. Opinions and forecasts regarding industries, companies, and/or the economy are all subject to change at any time, based on market and other conditions, and should not be construed as a recommendation.

Page 2

Slowing Growth In China And What It Means For The Global Economy

Concerns about China's economy have made headlines in recent weeks, as the country's interbank and money market interest rates soared to record highs last month. The spike in rates along with weakening economic data has fueled investors' anxiety about the safety of China's banking system and the sustainability of the country's economic growth.

A tightening in liquidity, along with an apparently deliberate move by the People's Bank of China to hold back on providing stimulus, drove overnight repo rates to surge as high as 30% in June, essentially freezing credit markets in China. The run-up in rates was driven by a number of factors, including fears that lending activities had become overstretched, speculation in the media that China could be facing a banking crisis, as well as actions by Chinese authorities to induce monetary tightening and discipline speculators in the country's shadow banking system. While China's central bank eventually injected liquidity into the system at the end of June and interbank lending rates have since eased, it has become evident to market participants that China's new leadership may be willing to tolerate higher interest rates and slower economic growth in pursuit of financial sector deleveraging and reform.

Last November, Xi Jinping was named head of the Communist Party in China and subsequently became President in March. Since he has taken office, Mr. Xi has indicated that he wants to revamp China's economic structure and move toward greater interest rate liberalization (allowing market forces to have a greater influence on interest rates). Also in March, Li Keqiang was elected by the Chinese Congress as Premier (China's head of government and an influential driver of economic policy).

Like Mr. Xi, Mr. Li has vowed to reduce the government's role in the economy and supports private enterprise and fiscal reform. These recent changes in leadership seem to be shifting the trajectory of the Chinese economy to some degree. Policymakers appear willing to accept short-term pain for longer-term gains.

Over the past decade, China's economic growth had been fueled by a number of factors including massive state spending, strong export growth (supported by low-cost labor), a burgeoning real estate market and easy access to credit. However, it appears that these factors are now decelerating.

In 2012, China's GDP grew by 7.8%. It was the first time growth had come in below 8% in more than a decade. For the second quarter of 2013, economists are forecasting GDP growth of roughly 7.6%, a deceleration from first quarter growth of 7.7%

(which was below expectations of 8%). Growth is expected to decelerate further in the third quarter to 7.4%, according to Bloomberg. While GDP growth of more than 7% may seem strong when compared to GDP growth of roughly 2% in the U.S., it represents a slowdown for China.

The deceleration in China's economy has been reflected in the recent decline in the country's closely watched purchasing managers' indices as well as the recent weakening in Chinese trade data. Manufacturing investment has declined, as evidenced by the drop in China's HSBC PMI for June to 48.2 (the lowest reading since November 2011). A reading below 50 is indicative of a contraction in factory activity. China's official PMI was 50.1 in June, a decline from 50.8 in May, pointing to lackluster manufacturing growth.

China's new leadership may be willing to tolerate higher interest rates and slower economic growth in pursuit of financial sector deleveraging and reform.

Meanwhile, Chinese exports declined 3.1% in June on a year-over-year basis compared to 1% year-over-year growth in May. In addition, Chinese imports fell 0.7% in June, reflecting weaker demand. Sluggish global economic growth, including an ongoing recession in Europe, has put pressure on China's exports, which has negatively impacted China's manufacturing sector and contributed to the country's overall slowdown.

We believe the most immediate risks related to China's slowdown are to commodity prices (where we have already seen significant volatility) and to second quarter corporate earnings (and second half 2013 forecasts) for companies that generate a significant portion of their revenues in China and/or companies that have been counting on China to be their growth-driver. We believe the slowdown in China also has the potential to spill over to other economies, especially in countries like Australia, South Korea, Taiwan, Indonesia, Japan, and Singapore. Europe, which is already struggling, is also likely to feel additional pain from China's slowdown. In terms of the U.S. economy, the fact that China's policymakers seem to be backing away from providing stimulus at the same time the U.S. Federal Reserve is mapping out its own exit from stimulus does, in our view, add risk to the sustainability of our economic recovery.

We believe speculation in the media about a potential banking crisis in China may be overblown. The difference between what happened in the U.S. during the financial crisis and the trouble that appears to be brewing in China is that all big Chinese banks are owned, or are at least partially controlled, by the government. As such, we

believe it is unlikely that Chinese authorities would allow a systemically important bank to fail. Nevertheless, Chinese policymakers have signaled less willingness to provide ongoing stimulus, and any risk to the financial stability of China's banks is a headwind for economic growth in our opinion.

This week, the International Monetary Fund lowered its growth forecast for the global economy to 3.1% in 2013 from its previous forecast of 3.3%. The IMF cited slower growth in developing economies such as China, as well as a deepening recession in the Eurozone, as reasons for the downward revision. The IMF cut its growth forecast for China to 7.7% in 2013 from its previous forecast of 8.3%. The downward revision to the IMF's growth forecast for the U.S. was less severe, down just 0.2 percentage points to 1.7%.

Overall, we believe the structural changes taking place in China will be a headwind to the global economy over the near term. However, we believe the country's new leadership regime is focused on putting China on a longer-term path to stability and consumer-led (rather than government-led) economic growth.

- Shelly Henbest
VP, Credit Analyst

RISKS AND OTHER IMPORTANT CONSIDERATIONS

This report is provided for informational purposes only and should not be construed as specific investment or legal advice. The information contained herein was obtained from sources believed to be reliable as of the date of publication, but may become outdated or superseded at any time without notice. Any opinions or views expressed are based on current market conditions and are subject to change. This report may contain forecasts and forward-looking statements which are inherently limited and should not be relied upon as an indicator of future results. Past performance is not indicative of future results. This report is not intended to constitute an offer, solicitation, recommendation or advice regarding any securities or investment strategy and should not be regarded by recipients as a substitute for the exercise of their own judgment.

Fixed income investments are subject to interest, credit, and market risk. Interest rate risk: the value of fixed income investments will decline as interest rates rise. Credit risk: the possibility that the borrower may not be able to repay interest and principal. Low rated bonds generally have to pay higher interest rates to attract investors willing to take on greater risk. Market risk: a decline due to economic conditions, especially during periods of rising interest rates.

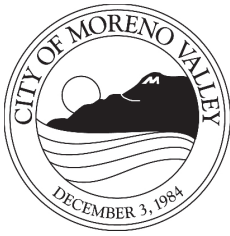

APPROVALS	
BUDGET OFFICER	<i>me</i>
CITY ATTORNEY	<i>SMB</i>
CITY MANAGER	<i>d</i>

Report to City Council

TO: Mayor and City Council

FROM: Ahmad R. Ansari, P.E., Public Works Director/City Engineer

AGENDA DATE: August 27, 2013

TITLE: ADOPT RESOLUTION NO. 2013-68 APPROVING THE RELOCATION PLAN FOR ELIGIBLE OCCUPANTS OF A SINGLE FAMILY RESIDENCE LOCATED AT 13597 NASON STREET (APN 487-470-017) FOR THE NASON STREET FROM CACTUS AVENUE TO FIR AVENUE STREET IMPROVEMENT PROJECT – PROJECT NO. 801 0001 70 77

RECOMMENDED ACTION

Recommendation:

1. Adopt Resolution No. 2013-68 approving the Relocation Plan for eligible occupants of a single family residence located at 13597 Nason Street (APN: 487-470-017). Resolution No. 2013-68, a Resolution of the City Council of the City of Moreno Valley, California, Approving the Relocation Plan for Eligible Occupants of a single family residence located at 13597 Nason Street (APN 487-470-017) for the Nason Street from Cactus Avenue to Fir Avenue Street Improvement Project – Project No. 801 0001 70 77.

BACKGROUND

The Nason Street from Cactus Avenue to Fir Avenue Street Improvement project (Project) will result in a total of four (4) full lanes of street improvements on Nason Street between Cactus Avenue and Fir Avenue. In order to construct the necessary improvements, right of way (ROW) acquisition is required from several parcels. A single-family residence (SFR) is situated on one of these parcels (APN: 487-470-017), located at 13597 Nason Street.

DISCUSSION

The proposed Project requires the acquisition and demolition of one SFR, which consequently results in the permanent relocation of one tenant-occupied household. For this particular parcel, only the necessary right of way for the street widening will be acquired. The City is not seeking acquisition of the whole property.

One tenant-occupied household will be relocated as part of the Project. The proposed displacement triggers relocation assistance obligations under State Relocation Law and the State Relocation Guidelines. The relocation assistance obligations require a Relocation Plan (Plan) addressing the circumstances and needs of those persons potentially displaced by the project and a mandatory 30 day review of the Plan by the impacted parties.

Overland, Pacific & Cutler, Inc. (OPC), real property consultants for the project, has met with the occupants of the subject SFR and prepared the Plan (Attachment 3). The 30 day public review period has expired and no public comment was submitted. Based on the Plan, the estimated cost to relocate the occupants is \$63,060 (including 20% contingency).

ALTERNATIVES

1. Adopt the proposed Resolution approving the Relocation Plan for eligible occupants of the SFR located at 13597 Nason Street (APN 487-470-017). *This alternative will allow the City to begin negotiations to acquire right of way needed for construction of this essential project.*
2. Do not adopt the proposed Resolution approving the Relocation Plan for eligible occupants of the SFR located at 13597 Nason Street (APN 487-470-017). *This alternative will not allow the City to begin negotiations to acquire right of way and will delay construction of this essential project.*

FISCAL IMPACT

Funding for the proposed ROW acquisition is included in the current Fiscal Year 2013/2014 budget. The design and construction of the project is funded with the proceeds from the California Communities Gas Tax Revenue Certificates of Participation (COPS), Series 2011B (TRIP – Total Road Improvement Program) in the amount of \$15 Million (overall project budget). These funds have been allocated for the Nason Street from Cactus Avenue to Fir Avenue Street Improvement project and cannot be utilized for operational activities. There is no impact on the City's General Fund.

BUDGETED FUNDS FOR DESIGN, RIGHT OF WAY, AND CONSTRUCTION:

Fiscal Year 2013/2014 Budget

(Account No. 2000-70-77-80001 / Project No. 801 0001 70 77) \$14,300,000

ESTIMATED PROJECT COSTS:

Remaining Design and Design Management Costs	\$550,000
Right of Way.....	\$1,450,000
Utility Relocation Costs (including SCE Engineering Deposit)*	\$2,300,000
Construction and Construction Management Costs	<u>\$10,000,000</u>
Total Estimated Project Costs	\$14,300,000

*An additional \$850,000 of separate SCE Rule 20A funds is also estimated for Utility Relocation

CITY COUNCIL GOALS

Public Safety:

Provide a safe and secure environment for people and property in the community, control the number and severity of fire and hazardous material incidents, and provide protection for citizens who live, work and visit the City of Moreno Valley.

Public Facilities and Capital Projects:

Ensure that needed public facilities, roadway improvements, and other infrastructure improvements are constructed and maintained.

Positive Environment:

Create a positive environment for the development of Moreno Valley's future.

NOTIFICATION

The Plan was provided to the occupants of the subject property at least 30 days prior to the presentation of this report. The City's real property consultant, OPC, also met in person with the occupants of the subject property to fully explain the Plan.

ATTACHMENTS

- Attachment 1: Location Map
- Attachment 2: Proposed Resolution
- Attachment 3: Relocation Plan

Prepared By:
Lorenz R. Gonzales
Senior Engineer, P.E.

Department Head Approval:
Ahmad R. Ansari, P.E.
Public Works Director/City Engineer

Concurred By:
Prem Kumar, P.E.
Deputy Public Works Director/Assistant City Engineer

Council Action	
Approved as requested:	Referred to:
Approved as amended:	For:
Denied:	Continued until:
Other:	Hearing set for:

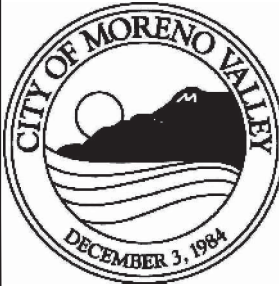
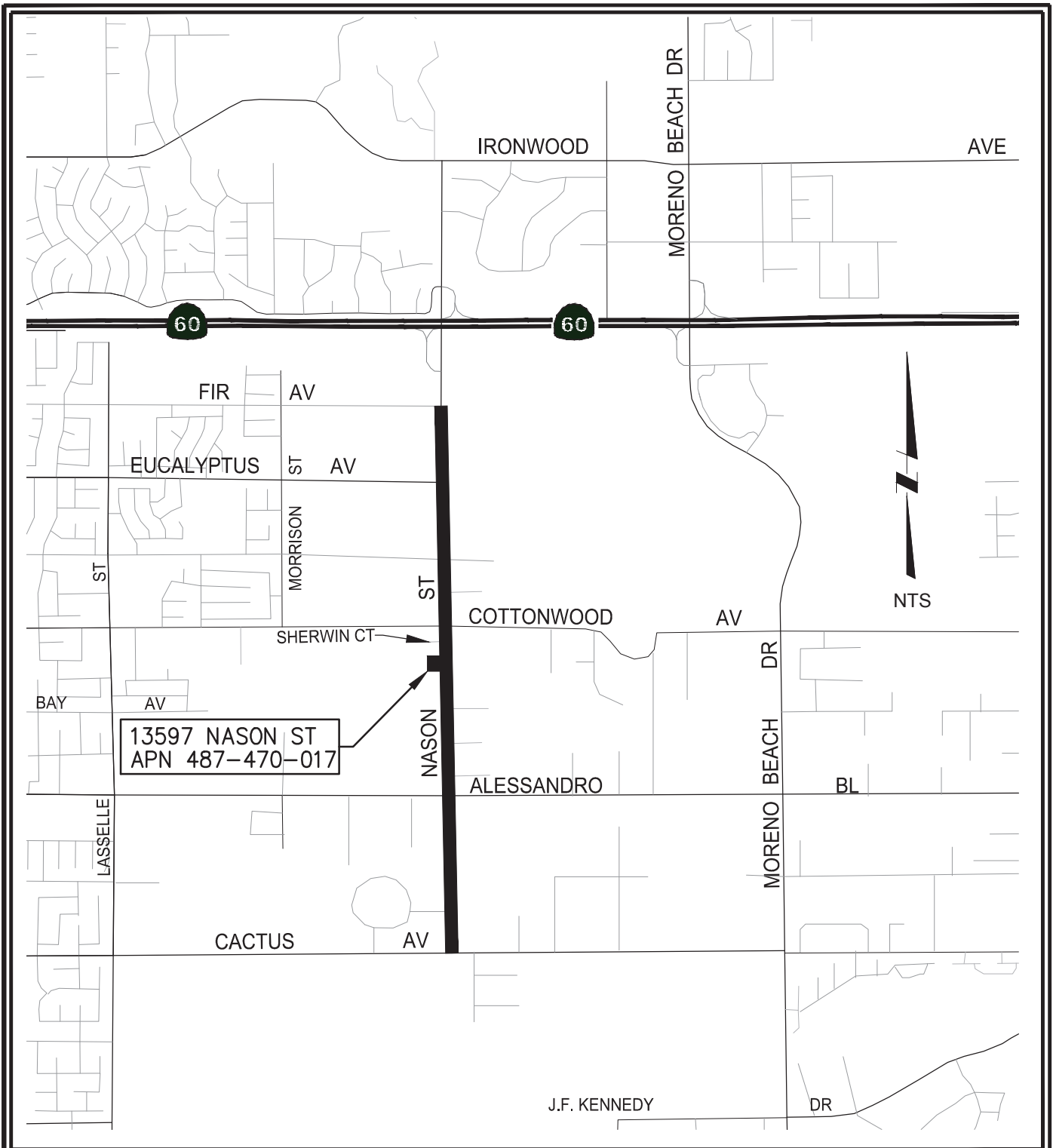

LOCATION MAP

Public Works Department Capital Projects Division	NASON STREET FROM CACTUS AVENUE TO FIR AVENUE STREET IMPROVEMENT PROJECT RELOCATION PLAN
Scale: None	PROJECT NUMBER 801 0001 70 77
ATTACHMENT 1	

This page intentionally left blank.

RESOLUTION NO. 2013-68

A RESOLUTION OF THE CITY COUNCIL OF THE CITY OF MORENO VALLEY, CALIFORNIA, APPROVING THE RELOCATION PLAN FOR ELIGIBLE OCCUPANTS OF A SINGLE FAMILY RESIDENCE LOCATED AT 13597 NASON STREET (APN 487-470-017) FOR THE NASON STREET FROM CACTUS AVENUE TO FIR AVENUE STREET IMPROVEMENT PROJECT – PROJECT NO. 801 0001 70 77

WHEREAS, the State Relocation Law (California Government Code Section 7260 et seq.) and the State Relocation Guidelines (California Code of Regulations, Title 25, Chapter 6 et seq.) require the City to approve a relocation plan and provide relocation assistance and benefits to eligible residential and business occupants that are either permanently or temporarily displaced; and

WHEREAS, the City, pursuant to the State Relocation Law and the State Relocation Guidelines, has prepared a Relocation Plan, which is attached to this resolution; and

WHEREAS, the proposed action to approve the Relocation Plan is an administrative action and does not constitute a project under the California Environmental Quality Act per Guidelines Section 15262.

NOW, THEREFORE, THE CITY COUNCIL OF THE CITY OF MORENO VALLEY, CALIFORNIA, DOES HEREBY RESOLVE AS FOLLOWS:

1. The Relocation Plan for eligible occupants of the Site is approved.
2. The City Manager and/or his designee is hereby authorized and directed to act on the City's behalf on all matters pertaining to the approved Relocation Plan including entering into agreement(s) with eligible occupants and payment of benefits to eligible occupants.
3. This resolution shall become effective immediately upon adoption.

1
Resolution No. 2013-68
Date Adopted: August 27, 2013

APPROVED AND ADOPTED this 27th day of August, 2013.

Mayor of the City of Moreno Valley

ATTEST:

City Clerk

APPROVED AS TO FORM:

City Attorney

Resolution No. 2013-68²
Date Adopted: August 27, 2013

RESOLUTION JURAT

STATE OF CALIFORNIA)
COUNTY OF RIVERSIDE) ss.
CITY OF MORENO VALLEY)

I, Jane Halstead, City Clerk of the City of Moreno Valley, California, do hereby certify that Resolution No. 2013-68 was duly and regularly adopted by the City Council of the City of Moreno Valley at a regular meeting thereof held on the 27th day of August, 2013 by the following vote:

AYES:

NOES:

ABSENT:

ABSTAIN:

(Council Members, Mayor Pro Tem and Mayor)

CITY CLERK

(SEAL)

3
Resolution No. 2013-68
Date Adopted: August 27, 2013

This page intentionally left blank.

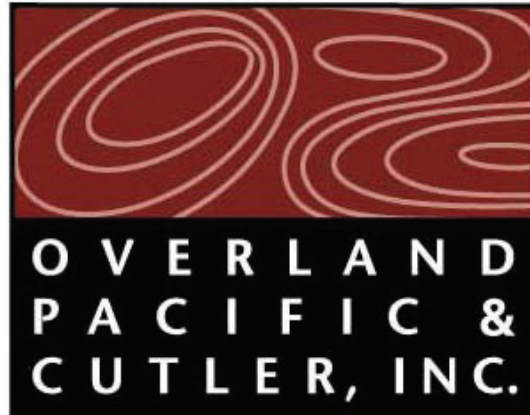

Nason Street Widening Project From Cactus Avenue to Fir Avenue

FINAL RELOCATION PLAN

Prepared for:
City of Moreno Valley
14177 Frederick Street
Moreno Valley, CA 92552

By:

Overland, Pacific & Cutler, Inc.
2280 Market Street, Suite 200
Riverside, California 92501
(951) 683-2353

July 2013

Adopted

Date _____

Contents

Introduction	1
I. Project Description.....	2
A. Regional Location.....	2
B. General Demographic and Housing Characteristics	4
II. Assessment of Relocation Needs.....	5
A. Survey Method	5
B. Field Survey Data.....	5
1. Current Occupants.....	5
2. Replacement Housing Needs.....	5
3. Income.....	5
4. Ethnicity/Language	6
5. Senior/Handicapped Households.....	6
6. Preferred Relocation Areas	6
III. Relocation Resources	7
A. Methodology	7
B. Replacement Housing Availability.....	7
1. Residential Rental Housing	7
2. Summary	7
C. Related Issues.....	7
1. Concurrent Residential Displacement	7
2. Temporary Housing	8
IV. The Relocation Program	9
A. Advisory Assistance.....	9
B. Relocation Benefits	10
1. Residential Moving Expense Payments.....	11
2. Rental Assistance to Tenants Who Choose to Rent	11
3. Downpayment Assistance to Tenants Who Choose to Purchase	13
4. Payment to Non-Tenured Residential Tenants	13
C. Determination of Comparable Housing.....	13
D. General Information Regarding the Payment of Relocation Benefits	13
E. Last Resort Housing	14
F. Relocation Tax Consequences.....	14
V. Administrative Provisions	16
A. Notices	16
B. Privacy of Records.....	17
C. Grievance Procedures	17
D. Eviction Policy.....	17
E. Citizen Participation	17
F. Projected Date of Displacement.....	18
G. Estimated Relocation Costs	18

List of Tables

Table 1: 2010 Census Population – City of Moreno Valley and Impacted Tract	4
--	---

Table 2: 2010 Census Housing Units – City of Moreno Valley and Impacted Tract..... 4
 Table 3: Availability and Cost of Replacement Rental Housing..... 7
 Table 4: Schedule of Fixed Moving Payments..... 11
 Table 5: Computation of Rental Assistance Payments (Tenants).....12

List of Figures

Figure 1: Regional Project Location..... 2
 Figure 2: Project Site Location and Description 3

List of Exhibits

- Exhibit A: Residential Relocation Interview Form
- Exhibit B: HUD Income Limits – Riverside County
- Exhibit C: Residential Informational Brochure
- Exhibit D: Public Comments and Response

Introduction

The City of Moreno Valley (the “City”) has authorized the preparation of a Relocation Plan to be undertaken in connection with the commencement of the proposed street improvements necessary to widen Nason Street from Cactus Avenue to Fir Avenue in Moreno Valley. The proposed Nason Street Widening Project (“Project”) requires the acquisition of necessary right of way to widen Nason Street from Cactus Avenue to Fir Avenue. This area on Nason Street from Cactus Avenue to Fir Avenue is an existing two to four lane road that would be improved into a four to six lane road through pavement widening, curb, gutter and median construction/reconstruction, traffic signal upgrades, storm drainage modifications, undergrounding of utility lines, installation/modification of water facilities, sidewalk, and bicycle lanes, side street intersection improvements, and American with Disabilities Act (ADA) ramp and bus bay construction. The improvement would require new right of way acquisition of vacant and improved land.

The currently proposed phase of the Project requires a partial acquisition which impacts a single-family dwelling along Nason Street in City of Moreno Valley jurisdiction. The proposed Project would involve the acquisition and demolition of one single-family residence (SFR) and permanent relocation of one household to accommodate the actions of the proposed Project.

The needs and characteristics of the displacee population, available relocation resources and the City’s program to provide assistance to each affected person are general subjects of this Relocation Plan (Plan). This Plan conforms to the requirements of the California Relocation Assistance Law, *Government Code* §7260, et seq. (Law), the Relocation Assistance and Real Property Acquisition Guidelines adopted by the Department of Housing and Community Development and Title 25, *California Code of Regulations* §6000, et seq. (Guidelines).

This Plan is organized in five sections:

1. Project description (**SECTION I**);
2. Assessment of the relocation needs of persons subject to displacement (**SECTION II**);
3. Assessment of available replacement housing units within the City of Moreno Valley and surrounding communities (**SECTION III**);
4. Description of the City’s relocation program (**SECTION IV**);
5. Description of the City’s outreach efforts, Project timeline and budget (**SECTION V**).

I. Project Description

A. Regional Location

The Project is located in the City of Moreno Valley in Riverside County. Moreno Valley is located approximately 60 miles east of the City of Los Angeles and is easily accessible by SR-60 and Interstate 215 (I-215). Adjacent communities include Riverside, Loma Linda, Beaumont, Yucaipa, Redlands, Grand Terrace, and Perris. (See Figure 1: Regional Project Location)

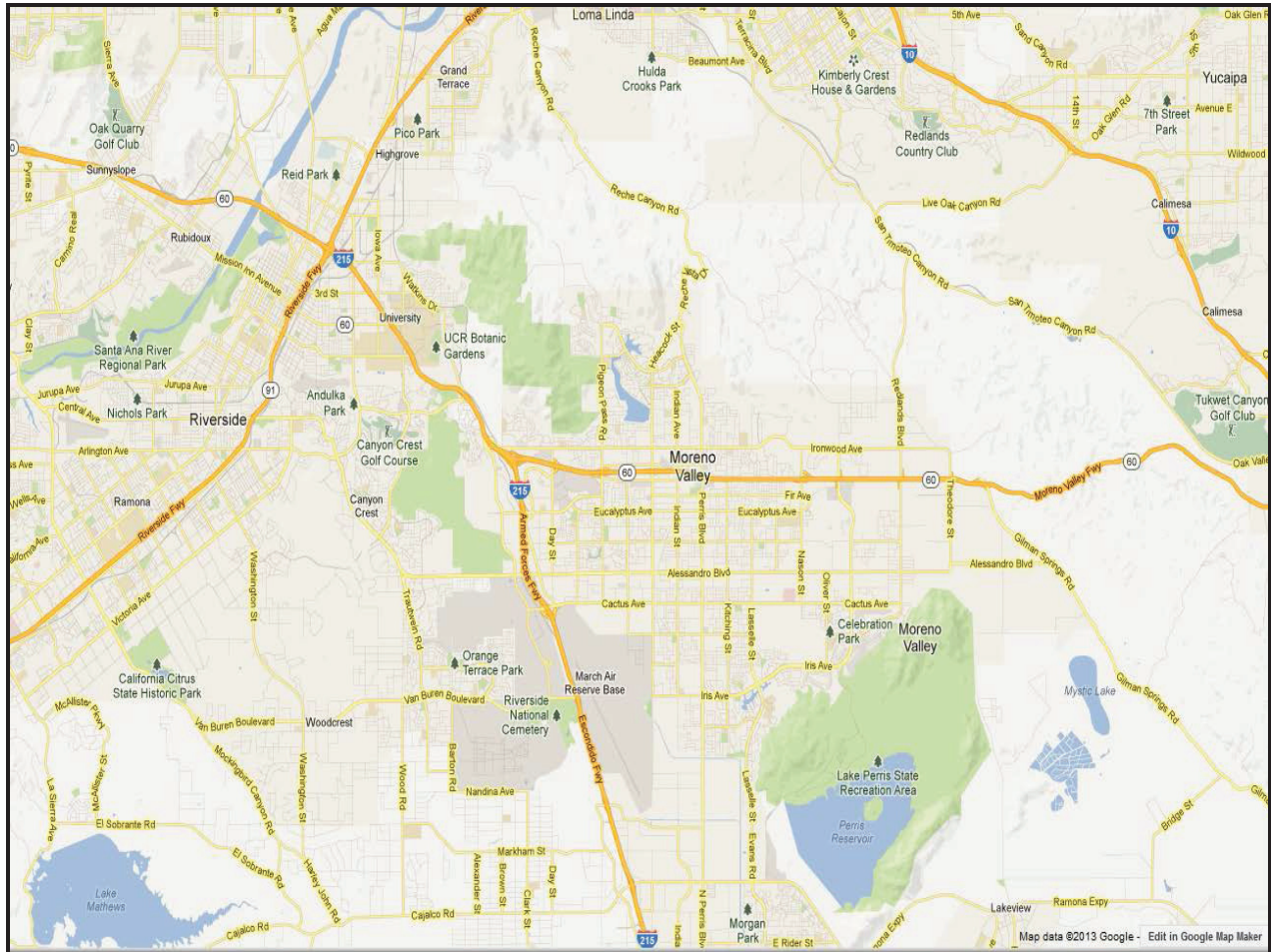
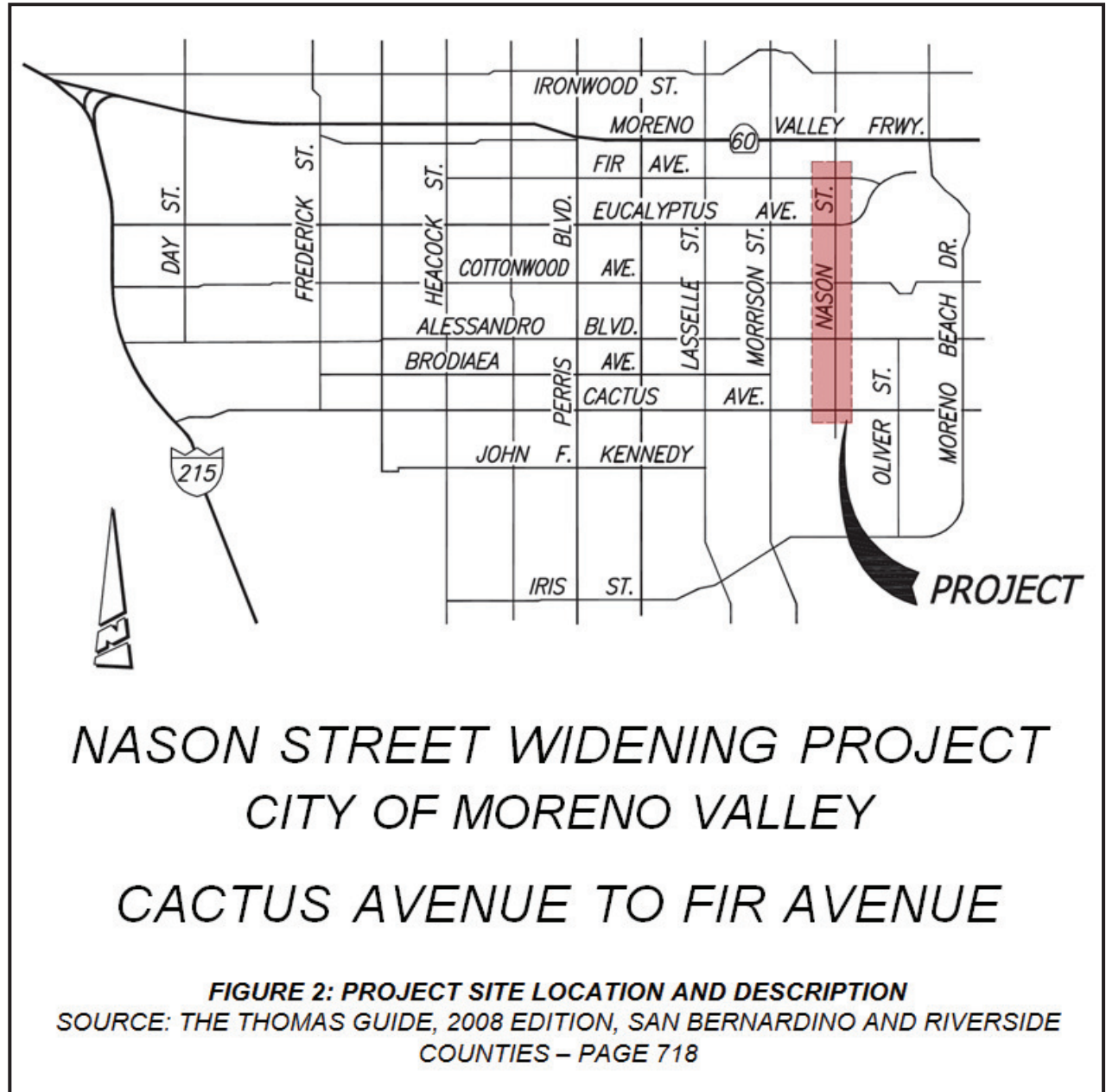

Figure 1: Regional Project Location

The Project site consists of the entire width of Nason Street from Cactus Avenue to Fir Avenue. (See Figure 2: Project Site Location and Description). The Project area of construction is approximately 28 acres.

Due to the nature of the proposed improvements and the impact on the subject property, there will be only one single-family dwelling that will need to be acquired.



B. General Demographic and Housing Characteristics

According to the 2010 U.S. Census, the population of the City of Moreno Valley is 193,365, and the population of the impacted Census Tract 426.22 is 4,107 (see **Table 1.**). Corresponding Census data concerning the housing mix is shown in **Table 2.**

Table 1: 2010 Census Population – City of Moreno Valley and Impacted Tract

Population	Tract 426.22	%	City	%
Total Population	4,107	100.0%	193,365	100.0%
White	1,430	34.8%	80,969	41.9%
Black or African American	789	19.2%	34,889	18.0%
American Indian or Alaska Native	38	0.9%	1,721	0.9%
Asian	635	15.5%	11,867	6.1%
Native Hawaiian or Other Pacific Islander	8	0.2%	1,117	0.6%
Some Other Race	953	23.2%	51,741	26.8%
Two or More Races	254	6.2%	11,061	5.7%
Hispanic or Latino (of Any Race)	1,816	44.2%	105,169	54.4%

Source: U.S. Census Bureau, QT-P3. Race, Hispanic or Latino, and Age: 2010.

Table 2: 2010 Census Housing Units – City of Moreno Valley and Impacted Tract

Type	Tract 426.22	%	City	%
Total Units	1,360	100.0%	55,559	100.0%
Owner-Occupied	651	47.9%	33,393	60.1%
Renter-Occupied	583	42.8%	18,199	32.8%
Vacant Housing Units	126	9.3%	3,967	7.1%
Available for Sale Only (of Total Vacant Units)	43	34.1%	1,196	30.1%
Available for Rent – Full Time Occupancy (of Total Vacant Units)	50	39.7%	1,486	37.5%
Sold or Rented – Not Occupied	12	9.5%	243	6.1%
Otherwise Not Available (e.g. seasonal, recreational, migratory, occasional use)	4	3.2%	131	3.3%
Other Vacant	17	13.5%	911	23.0%

Source: U.S. Census Bureau, QT-H1. General Housing Characteristics: 2010.

II. Assessment of Relocation Needs

A. Survey Method

To obtain information necessary for the preparation of this Plan, a personal interview with the residents to be permanently displaced was conducted in April 2013. The interviewer was successful in obtaining survey responses from the one occupied household in the Project area that is to be displaced. The data in this section of the Plan are based solely on the unsubstantiated responses of those individuals who participated in the survey.

Inquiries made of the residential occupants concerned household size and composition, income, rent and mortgage payments, length of occupancy, ethnicity, home language, physical disabilities, and replacement housing preferences. A sample of the residential interview form used in the interview process is presented as **Exhibit A** of this report.

B. Field Survey Data

1. Current Occupants

There is one residential household that will be relocated as part of the Project. At the time of the interview, based on data known for the one household to be displaced, there was one adult and three children (17 years or younger) onsite to be permanently displaced.

The project occupants reside in a SFR. Among the individual households to be displaced, there is one tenant-occupied household. The commonly accepted standard for housing density allows two persons per bedroom and one person in the common living area. Based on this criterion and available tenant data, there are no overcrowded units among the tenant-occupied households.

2. Replacement Housing Needs

Replacement housing needs, as expressed in this plan, are defined by the total number of required replacement units and distribution of those units by bedroom size. The projected number of required units by bedroom size is calculated by comparing survey data for household size with typical replacement housing occupancy standards. These standards, generally, allow for up to three persons in a one-bedroom unit, five persons in a two-bedroom unit, seven persons in a three-bedroom unit and nine or more persons in a four-bedroom unit.

Replacement units required for the displaced Project occupants include one three-bedroom SFR for rent.

3. Income

Income information was provided by the only tenant household. According to income standards for the County of Riverside (**Exhibit B**) adjusted for family size as published by the United States Department of Housing and Urban Development (HUD), the household qualifies as Very Low Income (39% of area median income).

4. *Ethnicity/Language*

Based on information from the single household who participated in the survey, the ethnicity stated was as Hispanic for the one household and the household reported English as their preferred language.

5. *Senior/Handicapped Households*

There are no known households identified with a senior head of household or spouse (62 years or older) in the Project. It was reported that a female child living in the household is a child with special needs that are due to behavioral issues.

6. *Preferred Relocation Areas*

The single household indicated that they preferred to remain within Riverside County in order to maintain current access to employment, schools, and family.

III. Relocation Resources

A. Methodology

For residential housing, a resource survey was initially conducted to identify available homes for rent and for sale within a ten-mile radius from the Project site and then expanding throughout the Moreno Valley area. The following source was utilized:

- Internet sources for rental and purchase opportunities, including the Multiple Listing Service.

B. Replacement Housing Availability

1. Residential Rental Housing

The rental replacement housing survey considered SFRs for rent in Moreno Valley. This data is summarized in **Table 3** below. The individual figures for number of units found by bedroom size are presented in the table alongside the number of units needed (shown in parentheses) to meet the re-housing obligations.

Table 3: Availability and Cost of Replacement Rental Housing

Bedroom Size	Three
# Found (# Needed)	74 (1)
Rent Range	\$995 - \$2,300
Median Rent	\$1,647.50

The median rent amount shown in the table is among the figures used to make benefit and budget projections for the Plan. This amount is, naturally, subject to change according to the market rates prevailing at the time of displacement.

2. Summary

Considering the above described availability of replacement housing resources gathered in April 2013, there are adequate replacement resources for the residential occupants.

Based on survey results of rental opportunities and the tenants' current rent, the tenant occupants will likely not have an increase in monthly rent. However, possible increases, if any, will be met through the Agency's obligation under the relocation regulations, including Last Resort Housing (LHR) requirements. (See Section IV.E, Last Resort Housing).

C. Related Issues

1. Concurrent Residential Displacement

At this time, there are no other current public projects causing significant displacements underway in the City of Moreno Valley or adjacent communities which would compete with the Project for needed housing resources. The funding source is California Communities Gas Tax

Revenue Certificates of Participation (COPS), Series 2011B (Total Road Improvement Program [TRIP]). As shown in Tables 3 and 4, there are adequate resources available for replacement sites. No residential displacee will be required to move without both adequate notice and access to available affordable decent, safe and sanitary housing.

2. Temporary Housing

No need for temporary housing is anticipated.

IV. The Relocation Program

The City's Relocation Program is designed to minimize hardship, be responsive to unique project circumstances, emphasize maintaining personal contact with all affected individuals, consistently apply all regulatory criteria to formulate eligibility and benefit determinations and conform to all applicable requirements.

The City has retained Overland, Pacific & Cutler, Inc. ("OPC") to administer the Relocation Program. OPC has worked on more than 3,000 public acquisition and relocation projects over the past 32 years. Additionally, OPC has an extensive resume of redevelopment and public works projects undertaken in the City of Moreno Valley and other Southern California communities. Experienced City staff will monitor the performance of OPC and be responsible to approve or disapprove OPC recommendations concerning eligibility and benefit determinations and interpretations of the City's policy.

The Relocation Program consists of two principal constituents: Advisory Assistance and Financial Assistance.

A. Advisory Assistance

Individuals who will need to move from existing homes will receive advisory assistance. Advisory assistance services are intended to:

- inform displacees about the relocation program
- help in the process of finding appropriate replacement accommodations
- facilitate claims processing
- maintain a communication link with the City
- coordinate the involvement of outside service providers

To follow through on the advisory assistance component of the relocation program and assure that the City meets its obligations under the law, relocation staff will perform the following functions:

1. Distribute appropriate written information concerning the City's relocation program;
2. Inform eligible project occupants of the nature of, and procedures for, obtaining available relocation assistance and benefits (see **Exhibit C**);
3. Determine the needs of each residential displacee eligible for assistance;
4. Provide residential displacees with at least three referrals to comparable replacement housing within a reasonable time prior to displacement;
5. Maintain an updated database of available housing resources, and distribute referral information to displacees for the duration of the Project;
6. Provide transportation to residential displacees, if necessary, to inspect replacement sites within the local area;

7. Offer special assistance to help elderly or disabled displacees find housing near friends, relatives, medical facilities, services and convenient transportation;
8. Provide continuously updated referrals to potential replacement sites within a reasonable time prior to displacement,
9. Supply information concerning federal and state programs and other governmental programs providing assistance to displaced persons;
10. Assist each eligible displacee in the preparation and submission of relocation assistance claims;
11. Provide additional reasonable services necessary to successfully relocate occupants;
12. Make benefit determinations and payments in accordance with applicable law and the City's adopted relocation guidelines;
13. Assure that no occupant is required to move without a minimum of 90 days written notice to vacate. This notice could be part of, separate from, or be an Order for Immediate Possession issued from the Court;
14. Inform all persons, subject to displacement, of the City's policies with regard to eviction and property management;
15. Establish and maintain a formal grievance procedure for use by displaced persons seeking administrative review of the City's decision with respect to relocation assistance; and,
16. Provide assistance that does not result in different or separate treatment due to race, color, religion, national origin, sex, marital status or other arbitrary circumstances.

B. Relocation Benefits

Specific eligibility requirements and benefit plans will be detailed on an individual basis with all displacees. In the course of personal interviews and follow-up visits, each displacee will be counseled as to available options and the consequences of any choice with respect to financial assistance.

Relocation benefits will be paid to eligible displacees upon submission of required claim forms and documentation in accordance with the City's administrative procedures. The City may process advance payment requests from determined eligibility amounts to mitigate hardships for residential occupants who do not have access to sufficient funds to initially secure replacement housing such as paying an escrow deposit or first month's rent and security deposit. Approved requests will be processed expeditiously to help avoid the loss of desirable, appropriate replacement housing.

1. Residential Moving Expense Payments

All residential occupants to be relocated will be eligible to receive a payment for moving expenses. Moving expense payments will be made based upon the actual cost of a professional move or a fixed payment based on a room-count schedule.

a. Actual Cost (Professional Move)

The displacee may elect to retain the services of a licensed professional mover, in which case the City will pay the actual cost of moving services, based on the lower of at least two (2) acceptable bids. (The City may, at its discretion, solicit competitive bids to determine the lowest, reasonable move cost.) After the move is complete, the displacee may request a direct payment from the City to the mover.

b. Fixed Payment (based on Room Count Schedule)

The displacee may, while taking full responsibility for the move, elect to receive a fixed payment for moving expenses based on a room count in the displacement dwelling. The fixed payment is a one-time, all inclusive allowance that does not require back-up documentation. The current schedule for fixed payments is set forth in **Table 4:**

Table 4: Schedule of Fixed Moving Payments

Unfurnished Dwelling									
Room count	1	2	3	4	5	6	7	8	Each additional
Amount	\$685	\$880	\$1,100	\$1,295	\$1,570	\$1,815	\$2,090	\$2,365	\$250
Furnished Dwelling									
Room count	1	each additional							
Amount	\$450	\$85							

Source: California Department of Transportation – June 2012

2. Rental Assistance to Tenants Who Choose to Rent

A tenant displaced from a dwelling may be entitled to a Replacement Housing Payment in the form of rental or downpayment assistance not-to-exceed \$5,250 (prior to consideration of eligibility for Last Resort Housing benefits – see Section IV.E, Last Resort Housing), if the displacee:

1. Has actually and lawfully occupied the displacement dwelling for at least 90 days immediately prior to the initiation of negotiations; and
2. Has rented, or purchased, and occupied a decent, safe, and sanitary replacement dwelling within one year (unless the Agency extends this period for good cause) after the date he or she moves from the displacement dwelling.

Rental Assistance payment amounts are equal to 42 times the difference between the base monthly rent and the lesser of:

1. The monthly rent and estimated average monthly cost of utilities for a comparable replacement dwelling; or
2. The monthly rent and estimated average monthly cost of utilities for the decent, safe and sanitary replacement dwelling actually occupied by displaced person.

The base monthly rent for the displacement dwelling is the lesser of:

1. The average monthly cost for rent and utilities at the displacement dwelling 90 days prior to the offer on the property. For owner-occupants or households, which pay no rent, Fair Market Rent will be used as a substitute for actual rent; or
2. Thirty percent (30%) of the displaced person’s average, monthly, adjusted gross household income. If a displacee refuses to provide appropriate evidence of income or is a dependent, the base monthly rent shall be determined to be the average monthly cost for rent and utilities at the displacement dwelling; or
3. The total of the amount designated for shelter and utilities if receiving a welfare assistance payment from a program that designated the amounts for shelter and utilities.

Table 5 illustrates the computation of a rental/downpayment assistance payment.

Table 5: Computation of Rental Assistance Payments (Tenants)

1. Old Rent	\$650	Old Rent, plus Utility Allowance
or		
2. Ability to Pay	\$700	30% of the Adjusted Gross Household Income*
3. Lesser of lines 1 or 2	\$650	Base Monthly Rental
Subtract From:		
4. Actual New Rent	\$750	Actual New Rent including Utility Allowance
or		
5. Comparable Rent	\$775	Determined by Agency, includes Utility Allowance
6. Lesser of lines 4 or 5	\$750	
7. Yields Monthly Need	\$100	Subtract line 3 from line 6
8. Rental Assistance Payment	\$4,200	Multiply line 7 by 42 months

*Gross income means the total amount of annual income of a household less the following: (1) a deduction for each dependent in excess of three; (2) a deduction of 10% of total income for the elderly or disabled head of household; (3) a deduction for recurring extraordinary medical expenses defined for this purpose to mean medical expenses in excess of 3% of total income, where not compensated for, or covered by insurance or other sources; (4) a deduction of reasonable amounts paid for the care of children or sick or incapacitate family members when determined to be necessary to employment of head of household or spouse, except that the amount shall not exceed the amount of income received by the person who would not otherwise be able to seek employment in the absence of such care.

3. Downpayment Assistance to Tenants Who Choose to Purchase

Displacees otherwise eligible to receive a Rental Assistance payment as previously described, may choose to utilize the full amount of their rental assistance eligibility amount (including Last Resort benefit) to purchase a home. Such payments shall be deposited directly into an escrow account with provisions that allow the Agency to recover its funds should the escrow be cancelled or not proceed in a timely manner. These funds can be used as a downpayment and/or to pay for eligible non-recurring closing costs.

4. Payment to Non-Tenured Residential Tenants

A residential tenant who has actually and lawfully occupied the displacement dwelling for less than 90 days immediately prior to the initiation of negotiations is entitled to receive a moving expense payment. Additionally, non-tenured residential tenants may qualify for a rental assistance payment under the provisions of Last Resort Housing assistance (see Section IV.E, Last Resort Housing). Such assistance is authorized when comparable replacement housing is not available at rental rates within the tenant's financial means (30% of gross monthly household income). Last Resort Housing assistance to non-tenured households is based solely on income.

C. Determination of Comparable Housing

Relocation staff will evaluate the cost of comparable replacement housing in the preparation of each individual Notice of Eligibility issued to residential displacees. For residential tenant occupants, the cost of comparable replacement housing will be determined by the comparative method.

D. General Information Regarding the Payment of Relocation Benefits

Claims and supporting documentation for relocation benefits must be filed with the City no later than 18 months after the date of displacement. The procedure for the preparation and filing of claims, and the processing and delivery of payments, will be as follows:

1. Claimant(s) will provide all necessary documentation to substantiate eligibility for assistance;
2. Relocation staff will review all necessary documentation including, but not limited to, income verification, lease documents and escrow material before reaching a determination as to which expenses are eligible for compensation;
3. Required claims forms will be prepared by relocation staff and presented to the claimant for review. Signed claims and supporting documentation will be returned to relocation staff and submitted to the City;
4. The City will review and approve claims for payment, or request additional information;
5. The City will issue benefit checks to claimants in the most secure, expeditious manner possible;

6. Final payments to residential displacees will be issued after confirmation that the Project premises have been completely vacated and actual residency at the replacement unit is verified;
7. Receipts of payment and all claims materials will be maintained in the relocation case file.

E. Last Resort Housing

Specifically, for renters, when the computed replacement housing assistance eligibility exceeds \$5,250 or replacement dwelling monthly rental costs (including utilities and other reasonable recurring expenses) exceeds 30% of the person's average monthly income, Last Resort Housing will have to be provided.

Therefore, if the Project is to go forward, the City will authorize its funds or funds authorized for the Project to provide housing of last resort. Funds will be used to make payments in excess of the monetary limit specified in the statute (\$5,250); hence, satisfying the requirement that "comparable replacement housing" is available.

A displaced tenant household will be entitled to consideration for supplementary benefits in the form of Last Resort Housing assistance when the computed replacement housing assistance eligibility exceeds \$5,250 or replacement dwelling monthly rental costs (including utilities and other reasonable recurring expenses) exceed 30% of the person's average monthly income (financial means) or when a tenant fails to meet the 90-day occupancy requirement and comparable replacement rental housing is not available within the displaced person's financial means. Calculations of Last Resort rental assistance benefits for tenants who fail to meet the 90-day occupancy requirement will be based solely on household income. Non 90-day qualifiers must meet basic eligibility requirements applied to all other displacees.

The City may pay Last Resort Housing payments in installments or a lump sum. Recipients of Last Resort rental assistance, who intend to purchase rather than re-rent replacement housing, will have the right to request a lump sum payment of all benefits in the form of downpayment assistance.

F. Relocation Tax Consequences

California Government Code Section 7269 indicates no relocation payment received shall be considered as income for the purposes of the Personal Income Tax Law, Part 10 (commencing with Section 170 01) of Division 2 of the Revenue and Taxation Code, or the Bank and Corporation Tax law, Part 11 (commencing with Section 23001) of Division 2 of the Revenue and Taxation Code. Furthermore, federal regulations (49 CFR Part 24, Section 24.209) also indicate that no payment received under this part (Part 24) shall be considered as income for the purpose of the Internal Revenue Code of 1954, which has been redesignated as the Internal Revenue Code of 1986. No federal dollars are anticipated for this project. Therefore, federal regulations may not apply and the Internal Revenue Service (IRS) may consider relocation payments as income. The preceding statement is not tendered as legal advice in regard to tax consequences, and displacees should consult with their own tax advisor or legal counsel to determine the current status of such payments.

(IRS Circular 230 disclosure: To ensure compliance with requirements imposed by the IRS, we inform you that any tax advice contained in this communication (including any attachments) was not intended or written to be used, and cannot be used, for the purpose of (i) avoiding tax-related penalties under the Internal Revenue Code or (ii) promoting marketing or recommending to another party any matters addressed herein)

V. Administrative Provisions

A. Notices

Each notice, which the City is required to provide to a Project occupant, shall be personally delivered or sent certified or registered first-class mail, return receipt requested and documented in the case file. Each notice will be written in plain, understandable language. Each notice will indicate the name and telephone number of a person who may be contacted for answers to questions and other needed help.

There are three principal notices:

1. the Information Statement
2. the Notice of Relocation Eligibility, and
3. the 90-Day Vacate Notice.

The Informational Statement is intended to provide potential relocatees with a general written description of the City's relocation program and basic information concerning benefits, conditions of eligibility, noticing requirements and appeal rights. (See **Exhibit C**)

A Notice of Relocation Eligibility (NOE) will be distributed to each residential relocatee. The NOE to residential relocatees contains a determination of eligibility for relocation assistance and a computation of a maximum entitlement based on information provided by the affected household and the analysis of comparable replacement properties undertaken by the relocation staff.

No lawful occupant will be required to move without having received at least 90 days advance written notice of the earliest date by which the move will be necessary. The 90-Day Vacate Notice will state a specific date as the earliest date by which the occupant may be required to move or state that the occupant will receive a further notice indicating, at least 60 days in advance, the specific date of the required move. The 90-Day Vacate Notice will not be issued to any residential displacee before a comparable replacement dwelling has been made available.

In addition to the three principal notices, relocation staff will issue timely written notification in the form of a Reminder Notice, which discusses the possible loss of rights and sets the expiration date for the loss of benefits to those persons who:

1. are eligible for monetary benefits
2. have moved from the acquired property, and
3. have not filed a claim for benefits.

Reminder Notices will be issued periodically throughout the qualification period. An attempt shall be made to make written contact with all non-responsive relocatees no later than within the last six months prior to the filing expiration date.

B. Privacy of Records

All information obtained from displacees is considered confidential and will not be shared without consent of the displacee or the City or as a requirement of a specific Public Records Request in accordance with State law. Relocation staff will comply with federal regulations concerning safeguarding of relocation files and their contents.

C. Grievance Procedures

The City's grievance policy will follow the standards described in Article 5 Section 6150, et seq. of the State guidelines. Briefly stated, displacees will have the right to ask for administrative review when they believe themselves aggrieved by a determination as to eligibility, the amount of payment, the failure to provide comparable replacement housing referrals or the City's property management practices.

Requests for review will be directed first to the Director of Public Works or an authorized designee of the City and subsequently to a formal Relocation Appeals Board, at the election of the appellant complainant. Details concerning the entire appeals process will be provided upon request.

D. Eviction Policy

The City recognizes that eviction is permissible only as a last resort, and that relocation records must be documented to reflect the specific circumstances surrounding any eviction. Eviction will only take place in cases of nonpayment of rent, serious violation of the rental agreement, a dangerous or illegal act in the unit, or if the household refuses all reasonable offers of alternate accommodation. In the event of an eviction for cause, the household may forfeit their eligibility for relocation benefits.

E. Citizen Participation

A community meeting regarding this Project phase was held on June 27, 2012 at the local high school that fronts Nason Street in the proposed Project area. As the process for considering the Project moves forward, the City will observe the following protocol:

1. Provide affected tenants with full and timely access to documents relevant to the relocation program;
2. Encourage meaningful participation in reviewing the Relocation Plan and monitoring the relocation assistance program;
3. Provide technical assistance necessary to interpret elements of the Relocation Plan and other pertinent materials;
4. Issue a general notice concerning the availability of the Plan for public review, as required, 30 days prior to its proposed approval; and
5. Include written or oral comments concerning the Plan as an attachment (**Exhibit D**) when it is forwarded to the City Council for approval.

F. Projected Date of Displacement

The City anticipates that a date specific Notice to Vacate will not be issued prior to **October 2013**. No resident will be required to vacate without a minimum of 90 days' notice. However, a resident may choose to vacate prior to a vacate notice being issued, once they have received their Notice of Eligibility, and be assured they will receive any replacement housing assistance and moving assistance to which they may be entitled.

G. Estimated Relocation Costs

The total budget estimate for relocation-related payments for this Project, including a 10 percent contingency, is **\$63,060**.

The Estimated relocation budget does not include any payments related to property acquisition. In addition, the budget does not consider the cost of any services necessary to implement the Plan and complete the relocation element of the Project.

If the Project is to be implemented, and circumstances arise that should change either the number of displaced occupants, or the nature of their activity, the City will authorize any additional compensable funds that may need to be appropriated. The City pledges to appropriate, on a timely basis, the funds necessary to ensure the successful completion of the Project, including funds necessary for Last Resort Housing as indicated in Section IV.E, of this Plan to meet its obligation under the relocation regulations.

Exhibit A
Residential Relocation Interview Form



Residential Relocation Interview

Client/Project:		Case ID:		
Site Address:		Total occupants:	Interview Date:	<input type="checkbox"/> Unoccupied
City, St, ZIP:			Interviewer:	<input type="checkbox"/> No Contact

INDIVIDUAL OCCUPANTS (use additional pages as needed)

1. Name:		Gender: F M	Employer/School:		
Relationship (list 1): HEAD OF HOUSEHOLD	<input type="checkbox"/> ID verified	Income srce (list 2):	Income/empl. description:	Hire/start date:	Mo Income:
Lawful presence (list 3):	Date of birth:				
Phone/fax/email:	Move-in date:				
Notes/special needs:					

2. Name:		Gender: F M	Employer/School:		
Relationship (list 1):	<input type="checkbox"/> ID verified	Income srce (list 2):	Income/empl. description:	Hire/start date:	Mo Income:
Lawful presence (list 3):	Date of birth:				
Phone/fax/email:	Move-in date:				
Notes/special needs:					

3. Name:		Gender: F M	Employer/School:		
Relationship (list 1):	<input type="checkbox"/> ID verified	Income srce (list 2):	Income/empl. description:	Hire/start date:	Mo Income:
Lawful presence (list 3):	Date of birth:				
Phone/fax/email:	Move-in date:				
Notes/special needs:					

4. Name:		Gender: F M	Employer/School:		
Relationship (list 1):	<input type="checkbox"/> ID verified	Income srce (list 2):	Income/empl. description:	Hire/start date:	Mo Income:
Lawful presence (list 3):	Date of birth:				
Phone/fax/email:	Move-in date:				
Notes/special needs:					

5. Name:		Gender: F M	Employer/School:		
Relationship (list 1):	<input type="checkbox"/> ID verified	Income srce (list 2):	Income/empl. description:	Hire/start date:	Mo Income:
Lawful presence (list 3):	Date of birth:				
Phone/fax/email:	Move-in date:				
Notes/special needs:					

6. Name:		Gender: F M	Employer/School:		
Relationship (list 1):	<input type="checkbox"/> ID verified	Income srce (list 2):	Income/empl. description:	Hire/start date:	Mo Income:
Lawful presence (list 3):	Date of birth:				
Phone/fax/email:	Move-in date:				
Notes/special needs:					

DWELLING			HOUSEHOLD		
Mailing Address:			<input type="checkbox"/> Primary residence of all occupants? (If not, explain in notes)		
City, St, ZIP:			<input type="checkbox"/> Can someone read/understand English? If not, language:		
Carbon Copy Address:			Race/Ethnicity: <input type="checkbox"/> American Indian/Alaskan <input type="checkbox"/> Asian		
City, St, ZIP:			<input type="checkbox"/> Black/African-American <input type="checkbox"/> Hawaiian/Pacific Islander		
Dwelling Type (list 4):			<input type="checkbox"/> Hispanic/Latino <input type="checkbox"/> White <input type="checkbox"/> Other <input type="checkbox"/> Mixed		
Bedrooms:	Attic/Utility/Storage:	Approx Sq Ft:	Subscribe to: <input type="checkbox"/> Land phone <input type="checkbox"/> TV service <input type="checkbox"/> Internet		
Kitchen:	Basement:	Bathrooms:	<input type="checkbox"/> Home-based business? (describe in notes)		
Living/family rooms:	Garage:	Garage Spaces:	<input type="checkbox"/> Rent rooms in dwelling? (describe in notes)		
Dining room:	Other/Extra:	Carport Spaces:	<input type="checkbox"/> On fixed income or public assistance? (describe in Occupants)		
Den/Office:	Total physical and content rooms to move:	Parking Spaces:	<input type="checkbox"/> Disabled occupants? (describe modifications/needs in Occupants)		
Total Rooms:		Number of cars:	Replacement site <u>special</u> needs (mark and describe in Notes)		
Air Cond: <input type="checkbox"/> Central <input type="checkbox"/> Wall/Window <input type="checkbox"/> Heat Pump <input type="checkbox"/> Evap./Swamp <input type="checkbox"/> None			<input type="checkbox"/> Employment access <input type="checkbox"/> Shopping		
Heating: <input type="checkbox"/> FAU <input type="checkbox"/> Radiant <input type="checkbox"/> Hot Water <input type="checkbox"/> Space Htr <input type="checkbox"/> Solar <input type="checkbox"/> Heat Pump			<input type="checkbox"/> Public transport <input type="checkbox"/> Religious		
Dwelling Condition: <input type="checkbox"/> Good <input type="checkbox"/> Fair <input type="checkbox"/> Poor			<input type="checkbox"/> Medical facilities/services <input type="checkbox"/> Social/Public services		
Neighborhood Condition: <input type="checkbox"/> Good <input type="checkbox"/> Fair <input type="checkbox"/> Poor			<input type="checkbox"/> School needs <input type="checkbox"/> Relatives/Ethnic		
Amenities:			<input type="checkbox"/> Childcare <input type="checkbox"/> Other special needs		
			<input type="checkbox"/> All occupants to move to the same dwelling? (if not, explain in notes)		
TENANT			Replacement dwelling preference: <input type="checkbox"/> Rent <input type="checkbox"/> Buy		
Rent terms: <input type="checkbox"/> Month-Month <input type="checkbox"/> Lease, months left:			Can relocate from: <input type="checkbox"/> Neighborhood <input type="checkbox"/> City <input type="checkbox"/> County <input type="checkbox"/> State		
<input type="checkbox"/> Rent reduced in exchange for service		<input type="checkbox"/> Unit furnished by tenant	Preferred relocation areas:		
Monthly contract rent: \$		Security deposit: \$	HOMEOWNER		
Landlord/manager name/ph:			Lot size (sq ft):	Date purchased:	Age (yrs):
<input type="checkbox"/> Written rental agreement available?		<input type="checkbox"/> Rent receipts available?	<input type="checkbox"/> Own clear, no mortg/loans	<input type="checkbox"/> Negative equity	# of stories:
<input type="checkbox"/> Receiving Section 8 or other housing assistance?			1st Loan Information		2nd Loan Information
Caseworker name/ph:			Lender:		Lender:
Monthly tenant portion of rent: \$			Loan Type (list 5):		Loan Type (list 5):
Annual family/child care expenses to allow work: \$			Current % Rate:		Current % Rate:
Annual non-reimbursed medical expenses: \$			Principal Balance: \$		Principal Balance: \$
Annual non-reimb. handicapped assistance expenses: \$			Original Date:		Original Date:
Utilities paid by tenant:		Pets:	Remaining months:		Remaining months:
<input type="checkbox"/> Gas: \$			Monthly P&I payment:		Monthly P&I payment:
<input type="checkbox"/> Electric: \$		Energy source: Gas Electr Oil Other	MOBILE HOME		
<input type="checkbox"/> Water: \$		Cooking Stove: <input type="checkbox"/> <input type="checkbox"/> <input type="checkbox"/> _____	Pad space: <input type="checkbox"/> Rent <input type="checkbox"/> Own		Coach: <input type="checkbox"/> Rent <input type="checkbox"/> Own
<input type="checkbox"/> Sewer: \$		Water Heater: <input type="checkbox"/> <input type="checkbox"/> <input type="checkbox"/> _____	Pad rent: \$		Make/Model:
<input type="checkbox"/> Trash: \$		Space Heat: <input type="checkbox"/> <input type="checkbox"/> <input type="checkbox"/> _____	Coach length (ft):		Year:
		Air Conditioning: <input type="checkbox"/> <input type="checkbox"/> <input type="checkbox"/> _____	Coach width (ft):		Decal #:

Exhibit B
HUD Income Limits – Riverside County

State Income Limits for 2012

See instructions on last page to use income limits to determine applicant eligibility and calculate affordable housing cost and rent

County	Income Category	Number of Persons in Household							
		1	2	3	4	5	6	7	8
Riverside County	Extremely Low	14,100	16,100	18,100	20,100	21,750	23,350	24,950	26,550
	4-Person Very Low Income	23,450	26,800	30,150	33,500	36,200	38,900	41,550	44,250
	Area Median Income	37,550	42,900	48,250	53,600	57,900	62,200	66,500	70,800
	63,300	44,300	50,650	56,950	63,300	68,350	73,450	78,500	83,550
	Moderate Income	53,150	60,750	68,350	75,950	82,050	88,100	94,200	100,250
Sacramento County	Extremely Low	16,000	18,300	20,600	22,850	24,700	26,550	28,350	30,200
	4-Person Very Low Income	26,650	30,450	34,250	38,050	41,100	44,150	47,200	50,250
	Area Median Income	42,650	48,750	54,850	60,900	65,800	70,650	75,550	80,400
	76,100	53,250	60,900	68,500	76,100	82,200	88,300	94,350	100,450
	Moderate Income	63,900	73,050	82,150	91,300	98,600	105,900	113,200	120,500
San Benito County	Extremely Low	16,700	19,050	21,450	23,800	25,750	27,650	29,550	31,450
	4-Person Very Low Income	27,800	31,750	35,700	39,650	42,850	46,000	49,200	52,350
	Area Median Income	44,450	50,800	57,150	63,450	68,550	73,650	78,700	83,800
	79,300	55,500	63,450	71,350	79,300	85,650	92,000	98,350	104,700
	Moderate Income	66,600	76,100	85,650	95,150	102,750	110,350	118,000	125,600
San Bernardino County	Extremely Low	14,100	16,100	18,100	20,100	21,750	23,350	24,950	26,550
	4-Person Very Low Income	23,450	26,800	30,150	33,500	36,200	38,900	41,550	44,250
	Area Median Income	37,550	42,900	48,250	53,600	57,900	62,200	66,500	70,800
	63,300	44,300	50,650	56,950	63,300	68,350	73,450	78,500	83,550
	Moderate Income	53,150	60,750	68,350	75,950	82,050	88,100	94,200	100,250
San Diego County	Extremely Low	16,900	19,300	21,700	24,100	26,050	28,000	29,900	31,850
	4-Person Very Low Income	28,150	32,150	36,150	40,150	43,400	46,600	49,800	53,000
	Area Median Income	45,000	51,400	57,850	64,250	69,400	74,550	79,700	84,850
	75,900	53,150	60,700	68,300	75,900	81,950	88,050	94,100	100,200
	Moderate Income	63,750	72,900	82,000	91,100	98,400	105,700	112,950	120,250
San Francisco County	Extremely Low	23,350	26,650	30,000	33,300	36,000	38,650	41,300	44,000
	4-Person Very Low Income	38,850	44,400	49,950	55,500	59,950	64,400	68,850	73,300
	Area Median Income	62,200	71,050	79,950	88,800	95,950	103,050	110,150	117,250
	103,000	72,100	82,400	92,700	103,000	111,250	119,500	127,700	135,950
	Moderate Income	86,500	98,900	111,250	123,600	133,500	143,400	153,250	163,150
San Joaquin County	Extremely Low	13,950	15,950	17,950	19,900	21,500	23,100	24,700	26,300
	4-Person Very Low Income	23,250	26,550	29,850	33,150	35,850	38,500	41,150	43,800
	Area Median Income	37,150	42,450	47,750	53,050	57,300	61,550	65,800	70,050
	66,300	46,400	53,050	59,650	66,300	71,600	76,900	82,200	87,500
	Moderate Income	55,700	63,650	71,600	79,550	85,900	92,300	98,650	105,000
San Luis Obispo County	Extremely Low	15,850	18,100	20,350	22,600	24,450	26,250	28,050	29,850
	4-Person Very Low Income	26,400	30,200	33,950	37,700	40,750	43,750	46,750	49,800
	Area Median Income	42,250	48,250	54,300	60,300	65,150	69,950	74,800	79,600
	75,400	52,800	60,300	67,850	75,400	81,450	87,450	93,500	99,550
	Moderate Income	63,350	72,400	81,450	90,500	97,750	105,000	112,200	119,450

See instructions on last page to use these income limits to determine applicant eligibility and calculate affordable housing

Exhibit C
Residential Informational Brochure

Relocation Assistance Informational Statement for Families and Individuals

(CA State)

Displacing Agency:
City of Moreno Valley

Project Name:
Nason Street Widening Project

Displacing Agency Representative:



Overland, Pacific & Cutler, Inc.
2280 Market St., Suite 200
Riverside, CA 92501-2117
Phone: (951) 683-2353

Informational Statement Content:

1. General Information
2. Assistance In Locating A Replacement Dwelling
3. Moving Benefits
4. Replacement Housing Payment - Tenants And Certain Others
5. Section 8 Tenants
6. Replacement Housing Payment – Homeowners
7. Qualification For And Filing Of Relocation Claims
8. Last Resort Housing Assistance
9. Rental Agreement
10. Evictions
11. Appeal Procedures – Grievance
12. Tax Status of Relocation Benefits
13. Non-Discrimination and Fair Housing
14. Additional Information And Assistance Available

Spanish speaking agents are available. Si necesita esta información en español, por favor llame a su agente.

Informational Statement for Families and Individuals

(CA State)

1. GENERAL INFORMATION

The dwelling in which you now live is in a project area to be improved by, or financed through, the Displacing Agency using state and/or local funds. If and when the project proceeds, and it is necessary for you to move from your dwelling, you may be eligible for certain benefits. You will be notified in a timely manner as to the date by which you must move. Please read this information, as it will be helpful to you in determining your eligibility and the amount of the relocation benefits you may receive under the state law. You will need to provide adequate and timely information to determine your relocation benefits. The information is voluntary, but if you don't provide it, you may not receive the benefits or it may take longer to pay you. We suggest you save this informational statement for reference.

The Displacing Agency has retained the professional firm of **Overland, Pacific & Cutler, Inc. (OPC)** to provide relocation assistance to you. The firm is available to explain the program and benefits. Their address and telephone number is listed on the cover.

PLEASE DO NOT MOVE PREMATURELY. THIS IS NOT A NOTICE TO VACATE YOUR DWELLING. However, if you desire to move sooner than required, you must contact your agent at Overland, Pacific & Cutler, Inc., so you will not jeopardize any benefits. This is a general informational brochure only, and is not intended to give a detailed description of either the law or regulations pertaining to the Displacing Agency's relocation assistance program.

Please continue to pay your rent to your current landlord, otherwise you may be evicted and jeopardize the relocation benefits to which you may be entitled to receive. Once the Displacing Agency acquires the property, you will also be required to pay rent to the Displacing Agency.

2. ASSISTANCE IN LOCATING A REPLACEMENT DWELLING

The Displacing Agency, through its representatives, will assist you in locating a comparable replacement dwelling by providing referrals to appropriate and available housing units. You are encouraged to actively seek such housing yourself.

When a suitable replacement dwelling unit has been found, your relocation agent will carry out an inspection and advise you as to whether the dwelling unit meets decent, safe and sanitary housing requirements. A decent, safe and sanitary housing unit provides adequate space for its occupants, proper weatherproofing and sound heating, electrical and plumbing systems. Your new dwelling must pass inspection before relocation assistance payments can be authorized.

3. MOVING BENEFITS

If you must move as a result of displacement by the Displacing Agency, you will receive a payment to assist in moving your personal property. The actual, reasonable and necessary expenses for moving your household belongings may be determined based on the following methods:

- A Fixed Moving Payment based on the number of rooms you occupy (see below); **or**
- A payment for your Actual Reasonable Moving and Related Expenses based on at least two written estimates and receipted bills; **or**
- A combination of both (in some cases).

For example, you may choose a Self-Move, receiving a payment based on the Fixed Residential Moving Cost Schedule shown below, plus contract with a professional mover to transport your grand piano and /or other items that require special handling. In this case, there may be an adjustment in the number of rooms which qualify under the Fixed Residential Moving Cost Schedule.

A. Fixed Moving Payment (Self-Move)

A Fixed Moving Payment is based upon the number of rooms you occupy and whether or not you own your own furniture. The payment is based upon a schedule approved by the Displacing Agency, and ranges, for example, from \$450.00 for one furnished room to \$2,365.00 for eight rooms in an unfurnished dwelling. (For details see the table). Your relocation agent will inform you of the amount you are eligible to receive, if you choose this type of payment.

If you select a fixed payment, you will be responsible for arranging for your own move, and the Displacing Agency will assume no liability for any loss or damage of your personal property. A fixed payment also includes utility hook-ups and other related moving fees.

Fixed Moving Schedule CALIFORNIA (Effective 2012)	
Occupant Owns Furniture:	
1 room	\$685
2 rooms	\$880
3 rooms	\$1,100
4 rooms	\$1,295
5 rooms	\$1,570
6 rooms	\$1,815
7 rooms	\$2,090
8 rooms	\$2,365
Each additional room	\$250
Occupant does NOT Own Furniture:	
1 room	\$450
Each additional room	\$85

B. Actual Moving Expense (Professional Move)

If you wish to engage the services of a licensed commercial mover and have the Displacing Agency pay the bill, you may claim the ACTUAL cost of moving your personal property up to 50 miles. Your relocation agent will inform you of the number of competitive moving bids (if any) which may be required, and assist you in developing a "mover" scope of services for Displacing Agency approval.

4. REPLACEMENT HOUSING PAYMENT - TENANTS AND CERTAIN OTHERS

You may be eligible for a payment of up to \$5,250.00 to assist you in renting or purchasing a comparable replacement dwelling. In order to qualify, you must either be a tenant who has occupied the present dwelling for at least 90 days prior to the initiation of negotiations or an owner who has occupied the present dwelling between 90 and 180 days prior to the initiation of negotiations.

A. Rental Assistance. If you qualify, and **wish to rent** your replacement dwelling, your maximum rental assistance benefits will be based upon the difference over a forty-two (42) month period between the rent you must pay for a comparable replacement dwelling and the lesser of your current rent and estimated utilities or thirty percent (30%) of your gross monthly household income. You will be required to provide your relocation agent with monthly rent and household income verification prior to the determination of your eligibility for this payment.

- OR -

- B. **Down-payment Assistance.** If you qualify, and **wish to purchase** a home as a replacement dwelling, you can apply up to the total amount of your rental assistance payment towards the down-payment and non-recurring incidental expenses. Your relocation agent will clarify procedures necessary to apply for this payment.

Where a tenant is sharing a dwelling with an owner-occupant and paying the owner-occupant rent for the privilege, the tenant shall not be entitled to more than one-half of the rental assistance otherwise payable.

5. SECTION 8 TENANTS

When you do move, you may be eligible to transfer your Section 8 eligibility to a replacement site. In such cases, a comparable replacement dwelling will be determined based on your family composition at the time of displacement and the current housing program criteria. This may not be the size of the unit you currently occupy. Your relocation agent will provide counseling and other advisory services along with moving benefits.

6. REPLACEMENT HOUSING PAYMENT - HOMEOWNERS

- A. If you own and occupy a dwelling to be purchased by the Displacing Agency for **at least 180 days** prior to the initiation of negotiations, you may be eligible to receive a payment of up to \$22,500.00 to assist you in purchasing a comparable replacement unit. This payment is intended to cover the following items:
1. **Purchase Price Differential** - An amount which, when added to the amount for which the Displacing Agency purchased your property, equals the lesser of the actual cost of your replacement dwelling; **or** the amount determined by the Displacing Agency as necessary to purchase a comparable replacement dwelling. Your relocation agent will explain both methods to you.
 2. **Mortgage Interest Differential** - The amount which covers the increased interest costs, if any, required to finance a replacement dwelling. Your relocation agent will explain limiting conditions.
 3. **Incidental Expenses** - Those one time incidental costs related to purchasing a replacement unit, such as escrow fees, recording fees, and credit report fees. Recurring expenses such as prepaid taxes and insurance premiums are not compensable.
- B. **Rental Assistance Option** - If you are an owner-occupant and choose to rent rather than purchase a replacement dwelling, you may be eligible for a rental assistance payment of up to the amount that you could have received under the Purchase Price Differential, explained above. The payment will be based on the difference between an economic rent of the dwelling you occupy and the rent you must pay for a comparable replacement dwelling.

If you receive a rental assistance payment, as described above, and later decide to purchase a replacement dwelling, you may apply for a payment equal to the amount you would have received if you had initially purchased a comparable replacement dwelling, less the amount you have already received as a rental assistance payment.

7. QUALIFICATION FOR, AND FILING OF, RELOCATION CLAIMS

To qualify for a Replacement Housing Payment, you must rent or purchase and occupy a comparable replacement unit **within one year from the following**:

- For a tenant, the date you move from the displacement dwelling.
- For an owner-occupant, the latter of:
 - a.** The date you receive final payment for the displacement dwelling, or, in the case of condemnation, the date the full amount of estimated just compensation is deposited in court; **or**
 - b.** The date you move from the displacement dwelling.

All claims for relocation benefits must be filed with the Displacing Agency **within eighteen (18) months** from the date on which you receive final payment for your property, or the date on which you move, whichever is later.

8. LAST RESORT HOUSING ASSISTANCE

If comparable replacement dwellings are not available when you are required to move, or if replacement housing is not available within the monetary limits described above, the Displacing Agency will provide Last Resort Housing assistance to enable you to rent or purchase a replacement dwelling on a timely basis. Last Resort Housing assistance is based on the individual circumstances of the displaced person. Your relocation agent will explain the process for determining whether or not you qualify for Last Resort assistance.

If you are a tenant, and you choose to purchase rather than rent a comparable replacement dwelling, the entire amount of your rental assistance and Last Resort eligibility must be applied toward the down-payment and eligible incidental expenses of the home you intend to purchase.

9. RENTAL AGREEMENT

As a result of the Displacing Agency's action to purchase the property where you live, you may become a tenant of the Displacing Agency. If this occurs, you will be asked to sign a rental agreement which will specify the monthly rent to be paid, when rent payments are due, where they are to be paid and other pertinent information.

10. EVICTIONS

Any person, who occupies the real property and is not in unlawful occupancy, is presumed to be entitled to relocation benefits. Except for the causes of eviction set forth below, no person lawfully occupying property to be purchased by the Agency will be required to move without having been provided with at least 90 days written notice from the Agency. Eviction will be undertaken only in the event of one or more of the following reasons:

- Failure to pay rent; except in those cases where the failure to pay is due to the lessor's failure to keep the premises in habitable condition, is the result of harassment or retaliatory action or is the result of discontinuation or substantial interruption of services;
- Performance of dangerous illegal act in the unit;
- Material breach of the rental agreement and failure to correct breach within the legally prescribed notice period;
- Maintenance of a nuisance and failure to abate within a reasonable time following notice;

- Refusal to accept one of a reasonable number of offers of replacement dwellings; or
- The eviction is required by State or local law and cannot be prevented by reasonable efforts on the part of the public entity.

11. APPEAL PROCEDURES - GRIEVANCE

Any person aggrieved by a determination as to eligibility for, or the amount of, a payment authorized by the Displacing Agency's Relocation Assistance Program may have the appeal application reviewed by the Displacing Agency in accordance with its appeals procedure. Complete details on appeal procedures are available upon request from the Displacing Agency.

12. TAX STATUS OF RELOCATION BENEFITS

California Government Code Section 7269 indicates no relocation payment received shall be considered as income for the purposes of the Personal Income Tax Law, Part 10 (commencing with Section 17001) of Division 2 of the Revenue and Taxation Code, or the Bank and Corporation Tax law, Part 11 (commencing with Section 23001) of Division 2 of the Revenue and Taxation Code. Furthermore, federal regulations (49 CFR Part 24, Section 24.209) also indicate that no payment received under this part (Part 24) shall be considered as income for the purpose of the Internal Revenue Code of 1954, which has been redesignated as the Internal Revenue Code of 1986. No federal dollars are anticipated for this project. Therefore, federal regulations may not apply and the IRS may consider relocation payments as income. The preceding statement is not tendered as legal advice in regard to tax consequences, and displacees should consult with their own tax advisor or legal counsel to determine the current status of such payments.

(IRS Circular 230 disclosure: To ensure compliance with requirements imposed by the IRS, we inform you that any tax advice contained in this communication (including any attachments) was not intended or written to be used, and cannot be used, for the purpose of (i) avoiding tax-related penalties under the Internal Revenue Code or (ii) promoting marketing or recommending to another party any matters addressed herein)

13. NON-DISCRIMINATION AND FAIR HOUSING

No person shall on the grounds of race, color, national origin or sex, be excluded from participation in, be denied the benefits of, or be subjected to discrimination under the Displacing Agency's relocation assistance program pursuant to Title VI of the Civil Rights Act of 1964, Title VIII of the Civil Rights Act of 1968, and other applicable state and federal anti-discrimination and fair housing laws. You may file a complaint if you believe you have been subjected to discrimination. For details contact the Displacing Agency.

14. ADDITIONAL INFORMATION AND ASSISTANCE AVAILABLE

Those responsible for providing you with relocation assistance hope to assist you in every way possible to minimize the hardships involved in relocating to a new home. Your cooperation will be helpful and greatly appreciated. If you have any questions at any time during the process, please do not hesitate to contact your relocation agent at Overland, Pacific & Cutler.

Exhibit D
Public Comments And Response

This page intentionally left blank.

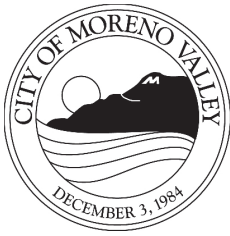

APPROVALS	
BUDGET OFFICER	<i>me</i>
CITY ATTORNEY	<i>SMB</i>
CITY MANAGER	<i>d</i>

Report to City Council

TO: Mayor and City Council

FROM: Ahmad R. Ansari, P.E., Public Works Director/City Engineer

AGENDA DATE: August 27, 2013

TITLE: RIGHT OF WAY EASEMENTS (APNS 487-470-023 AND 487-470-026) AND DRAINAGE EASEMENT (APN 487-470-023) FOR THE NASON STREET FROM CACTUS AVENUE TO FIR AVENUE STREET IMPROVEMENT PROJECT
PROJECT NO. 801 0001 70 77

RECOMMENDED ACTION

Recommendations:

1. Adopt Resolution No. 2013-69 granting a roadway easement on City owned parcels fronting the west side of Nason Street between Alessandro Boulevard and Cottonwood Avenue known as Assessor Parcel Numbers 487-470-023 and 487-470-026.
2. Authorize the granting of roadway easements for the City owned parcels known as Assessor Parcel Numbers 487-470-023 and 487-470-026.
3. Direct the City Clerk to forward the Resolution to the Mayor for execution and the roadway Easement Deeds to the Public Works Director/City Engineer for execution and to forward the documents to the County Recorder's office for recordation for Assessor Parcel Numbers 487-470-023 and 487-470-026.
4. Adopt Resolution No. 2013-70 granting a drainage easement on a City owned parcel on the northwest corner of Alessandro Boulevard and Nason Street known as Assessor Parcel Number 487-470-023.
5. Authorize the granting of a drainage easement for the City owned parcel known as Assessor Parcel Number 487-470-023.

6. Direct the City Clerk to forward the Resolution for Assessor Parcel Number 487-470-023 to the Mayor for execution and the Drainage Easement to the Public Works Director/City Engineer for execution and to forward the documents to the County Recorder's office for recordation for Assessor Parcel Number 487-470-023.

BACKGROUND

The Nason Street Improvement Project proposes to construct improvements along Nason Street from Cactus Avenue to Fir Avenue for a 4-Lane Divided Arterial Augmented Parkway with 120-foot right of way and 86-foot roadway width. The improvements will include curb and gutter, sidewalk, street lights, drainage facilities, and undergrounding of overhead utilities. Traffic signal modifications will be constructed at intersections with existing traffic signs and a new traffic signal at Medical Center Drive will also be completed.

On November 27, 2012, the environmental document, a Mitigated Negative Declaration (MND), was approved by City Council. On December 4, 2012, the Notice of Determination for the MND was filed with the Riverside County Clerk. The project is currently in the design and right of way phases.

DISCUSSION

In order to construct the proposed Nason Street Widening improvements, right of way is required from Assessor Parcel Numbers (APNs) 487-470-023 and 487-470-026, which are owned by the City of Moreno Valley. The two parcels are located on the west side of Nason Street between Alessandro Boulevard and Cottonwood Avenue. The appropriate manner for the City to grant any easements to itself is by both resolution and easement deeds. Once the Mayor executes the resolution and the easement deeds are executed by the Public Works Director/City Engineer, the documents will be recorded with the County Recorder to memorialize the roadway easements.

A drainage easement is also required from APN 487-470-026, which, as stated earlier, is owned by the City of Moreno Valley. The proposed drainage easement is located on the northwest corner of Nason Street and Alessandro Boulevard. Similarly, a resolution and drainage easement is recommended for the City to grant the easement to itself. As such, once the Mayor executes the resolution and the easement deed is executed by the Public Works Director/City Engineer, the documents will be recorded with the County Recorder to memorialize the drainage easement.

ALTERNATIVES

1. Approve and authorize the recommended actions as presented in this Staff Report. *This alternative will allow the City to acquire right of way needed for construction of this essential project.*

- 2. Do not approve and authorize the recommended actions as presented in this Staff Report. *This alternative will not allow the City to acquire right of way needed for construction of this essential project, thereby potentially causing the City to pay for the right of way in the future should the property be sold prior to the construction of the improvements.*

FISCAL IMPACT

Because the City owns the property from which it requires the subject easements, there is no acquisition cost associated with the recommended actions. The design and construction of the project is funded with the proceeds from the California Communities Gas Tax Revenue Certificates of Participation (COPS), Series 2011B (TRIP – Total Road Improvement Program) in the amount of \$15 Million (overall project budget). These funds have been allocated for the Nason Street from Cactus Avenue to Fir Avenue Street Improvement project and cannot be utilized for operational activities. There is no fiscal impact to the City’s General Fund.

ESTIMATED PROJECT COSTS:

Remaining Design and Design Management Costs	\$550,000
Right of Way.....	\$1,450,000
Utility Relocation Costs (including SCE Engineering Deposit)*	\$2,300,000
Construction and Construction Management Costs	\$10,000,000
Total Estimated Project Costs	\$14,300,000

*An additional \$850,000 of separate SCE Rule 20A funds is also estimated for Utility Relocation

CITY COUNCIL GOALS

Public Safety:

Provide a safe and secure environment for people and property in the community, control the number and severity of fire and hazardous material incidents, and provide protection for citizens who live, work and visit the City of Moreno Valley.

Public Facilities and Capital Projects:

Ensure that needed public facilities, roadway improvements, and other infrastructure improvements are constructed and maintained.

Positive Environment:

Create a positive environment for the development of Moreno Valley's future.

ATTACHMENTS

- Attachment 1: Location Map – Roadway and Drainage Easements
- Attachment 2: Proposed Resolution – Roadway Easements
- Attachment 3: Easement Deed - Roadway Easement (APN 487-470-023)
- Attachment 4: Easement Deed - Roadway Easement (APN 487-470-026)
- Attachment 5: Proposed Resolution – Drainage Easement
- Attachment 6: Drainage Easement - (APN 487-470-023)

Prepared By:
Lorenz R. Gonzales
Senior Engineer, P.E.

Department Head Approval:
Ahmad R. Ansari, P.E.
Public Works Director/City Engineer

Concurred By:
Prem Kumar, P.E.
Deputy Public Works Director/Assistant City Engineer

Council Action	
Approved as requested:	Referred to:
Approved as amended:	For:
Denied:	Continued until:
Other:	Hearing set for:

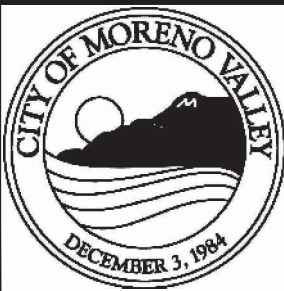
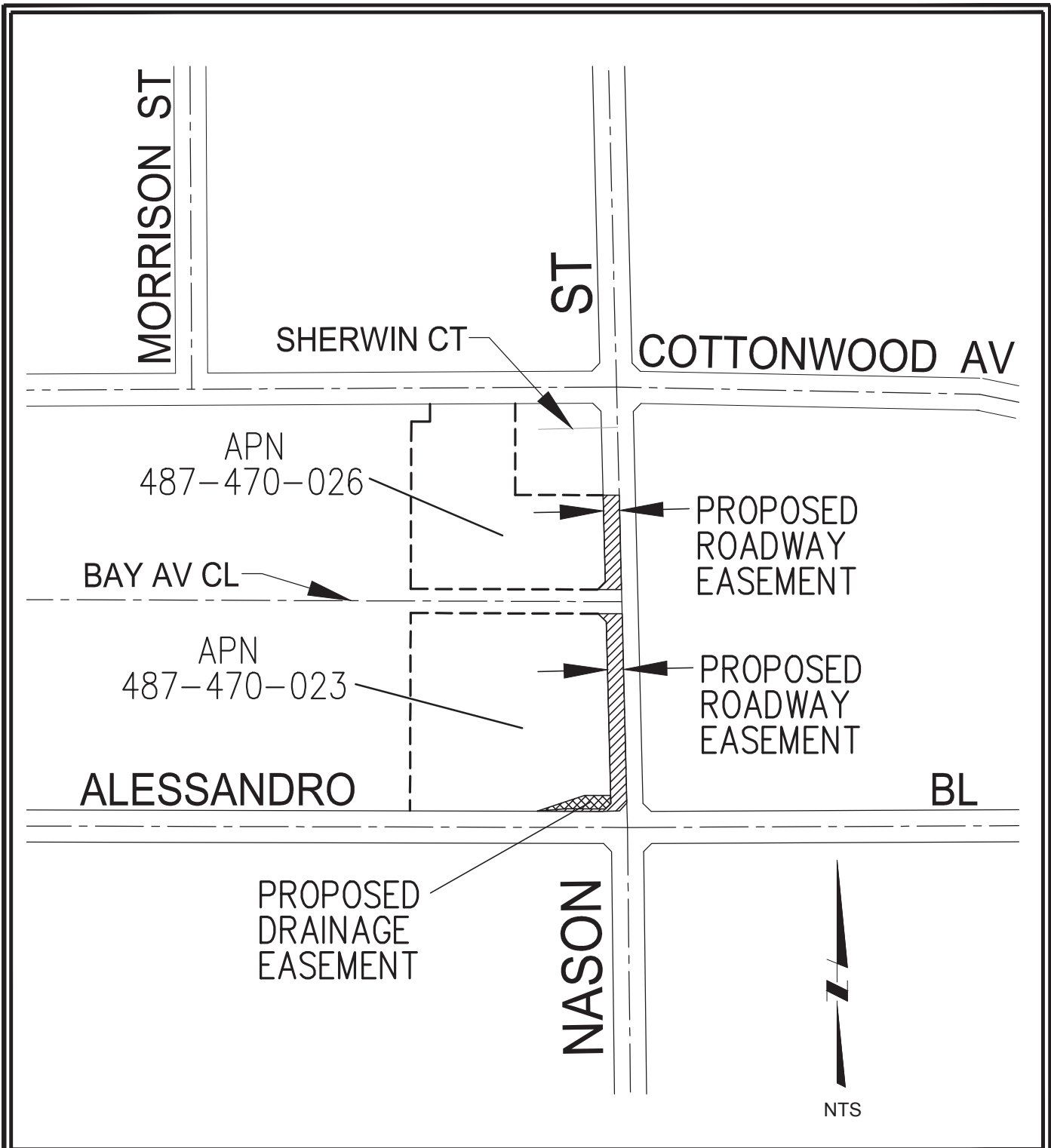

LOCATION MAP

Public Works Department
Capital Projects Division

Scale: None

ATTACHMENT 1

NASON STREET FROM CACTUS AVENUE
TO FIR AVENUE STREET IMPROVEMENT PROJECT
ROADWAY AND DRAINAGE EASEMENTS
PROJECT NUMBER 801 0001 70 77

This page intentionally left blank.

RESOLUTION NO. 2013-69

A RESOLUTION OF THE CITY COUNCIL OF THE CITY OF MORENO VALLEY, CALIFORNIA, GRANTING A PUBLIC ROADWAY EASEMENT ON CITY OWNED PARCELS FRONTING THE WEST SIDE OF NASON STREET BETWEEN ALESSANDRO BOULEVARD AND COTTONWOOD AVENUE

WHEREAS, the City of Moreno Valley owns two vacant land parcels identified as APNs 487-470-023 AND 487-470-026 fronting the west side of Nason Street between Alessandro Boulevard and Cottonwood Avenue; and

WHEREAS, these parcels may be developed in the future; and

WHEREAS, the City of Moreno Valley wishes to grant easement right of way for public highway purposes, including public utilities, private utilities permitted by the City, and public service facilities over, under, upon, across and within the real property, for future public use, which dedication is specifically described as:

Parcel One (APN 487-470-023): as described in the legal description marked Exhibit A and depicted on the plat map marked Exhibit B attached to the Resolution and incorporated herein by this reference; and

Parcel Two (APN 487-470-026): as described in the legal description marked Exhibit C and depicted on the plat map marked Exhibit D attached to the Resolution and incorporated herein by this reference; and

WHEREAS, the City of Moreno Valley City Council considers this grant of easement to be in the best interest of the City of Moreno Valley and of the public.

NOW, THEREFORE, THE CITY COUNCIL OF THE CITY OF MORENO VALLEY, CALIFORNIA, DOES HEREBY RESOLVE AS FOLLOWS:

1. The grant of easement as described above and depicted on Exhibits A through D attached to this Resolution are hereby approved.
2. The Mayor and City Clerk are hereby authorized to and directed to execute the Resolution and the Public Works Director/City Engineer is hereby authorized to and directed to execute the associated Easements Deeds on behalf of the City and record all such documents with the County Recorder.
3. This Resolution shall become effective immediately upon adoption.

1
Resolution No. 2013-69
Date Adopted: August 27, 2013

APPROVED AND ADOPTED this 27th day of August, 2013.

Mayor of the City of Moreno Valley

ATTEST:

City Clerk

APPROVED AS TO FORM:

City Attorney

Resolution No. 2013-69²
Date Adopted: August 27, 2013

RESOLUTION JURAT

STATE OF CALIFORNIA)
COUNTY OF RIVERSIDE) ss.
CITY OF MORENO VALLEY)

I, Jane Halstead, City Clerk of the City of Moreno Valley, California, do hereby certify that Resolution No. 2013-69 was duly and regularly adopted by the City Council of the City of Moreno Valley at a regular meeting thereof held on the 27th day of August, 2013 by the following vote:

AYES:

NOES:

ABSENT:

ABSTAIN:

(Council Members, Mayor Pro Tem and Mayor)

CITY CLERK

(SEAL)

Resolution No. 2013-69³
Date Adopted: August 27, 2013

Legal Description

POR. APN 487-470-023

IN THE CITY OF MORENO VALLEY, COUNTY OF RIVERSIDE, STATE OF CALIFORNIA BEING THAT PORTION OF LOTS 1 AND 8 IN BLOCK 104 OF MAP NO. 1 BEAR VALLEY AND ALESSANDRO DEVELOPMENT COMPANY AS FILED IN MAP BOOK 11, PAGE 10 THEREOF IN THE OFFICE OF THE COUNTY RECORDER OF SAN BERNARDINO COUNTY CALIFORNIA DESCRIBED AS FOLLOWS:

BEGINNING AT THE NORTHEAST CORNER OF SAID LOT 1;

THENCE SOUTH 00°25'47" WEST ALONG THE EAST LINES OF SAID LOTS 1 AND 8, A DISTANCE OF 1123.96 FEET TO THE NORTHWESTERLY LINE OF THAT CERTAIN PARCEL CONVEYED TO THE COUNTY OF RIVERSIDE BY DOCUMENT RECORDED APRIL 20, 1976 AS INSTRUMENT NO. 1976-52387, OFFICIAL RECORDS OF SAID RIVERSIDE COUNTY;

THENCE SOUTH 20°59'02" WEST, ALONG SAID NORTHWEST LINE A DISTANCE OF 102.52 FEET TO THE SOUTH LINE OF SAID LOT 8;

THENCE NORTH 89°33'53" WEST ALONG SAID SOUTH LINE, A DISTANCE OF 459.03 FEET;

THENCE LEAVING SAID SOUTH LINE, NORTH 84°43'29" EAST A DISTANCE OF 140.70 FEET TO A LINE THAT IS PARALLEL AND 14.00 FEET NORTH AS MEASURED AT RIGHT ANGLES FROM SAID SOUTH LINE;

THENCE SOUTH 89°33'53" EAST ALONG SAID PARALLEL LINE A DISTANCE OF 271.02 FEET;

THENCE NORTH 38°28'49" EAST A DISTANCE OF 29.21 FEET TO A LINE THAT IS PARALLEL AND 66.00 FEET WEST AS MEASURED AT RIGHT ANGLES FROM SAID EAST LINE OF LOT 8;

THENCE NORTH 00°25'47" EAST ALONG SAID PARALLEL LINE A DISTANCE OF 281.51 FEET TO THE BEGINNING OF A TANGENT CURVE CONCAVE EASTERLY AND HAVING A RADIUS OF 517.00 FEET;

THENCE NORTHERLY ALONG SAID CURVE THROUGH A CENTRAL ANGLE OF 05°54'58" AN ARC DISTANCE OF 53.38 FEET;

THENCE NORTH 06°20'45" EAST 35.75 FEET TO THE BEGINNING OF A TANGENT CURVE CONCAVE WESTERLY AND HAVING A RADIUS OF 1983.00 FEET;

THENCE NORTHERLY ALONG SAID CURVE THROUGH A CENTRAL ANGLE OF 05°54'58" AN ARC DISTANCE OF 204.76 FEET TO A LINE THAT IS PARALLEL AND 49.00 FEET WEST AS MEASURED AT RIGHT ANGLES FROM SAID EAST LINE OF LOT 1;

THENCE NORTH 00°25'47" EAST ALONG SAID PARALLEL LINE A DISTANCE OF 186.30 FEET;

THENCE NORTH 00°08'35" WEST 300.01 FEET TO A LINE THAT IS PARALLEL AND 52.00 FEET WEST AS MEASURED AT RIGHT ANGLES FROM SAID EAST LINE OF LOT 1;

THENCE NORTH 00°25'47" EAST ALONG SAID PARALLEL LINE A DISTANCE OF 104.91 FEET;

THENCE NORTH 46°12'25" WEST A DISTANCE OF 24.76 FEET TO A POINT ON THE NORTH LINE OF SAID LOT 1, SAID POINT BEING 70.00 FEET WEST ALONG SAID NORTH LINE FROM SAID NORTHEAST CORNER OF LOT 1;

THENCE SOUTH 89°33'43" EAST ALONG SAID NORTH LINE OF LOT 1 A DISTANCE OF 70.00 FEET TO THE POINT OF BEGINNING;

AREA = 71,684 SF OR 1.646 ACRES

ALSO AS SHOWN ON EXHIBIT "B" ATTACHED HERETO AND BY THIS REFERENCE MADE A PART HEREOF.

THIS DESCRIPTION WAS PREPARED BY ME OR UNDER MY DIRECTION IN CONFORMANCE WITH THE REQUIREMENTS OF THE LAND SURVEYORS ACT.



MARK S. BROWN, L.S. 5655

2/4/2013
DATE

J.M
PREP

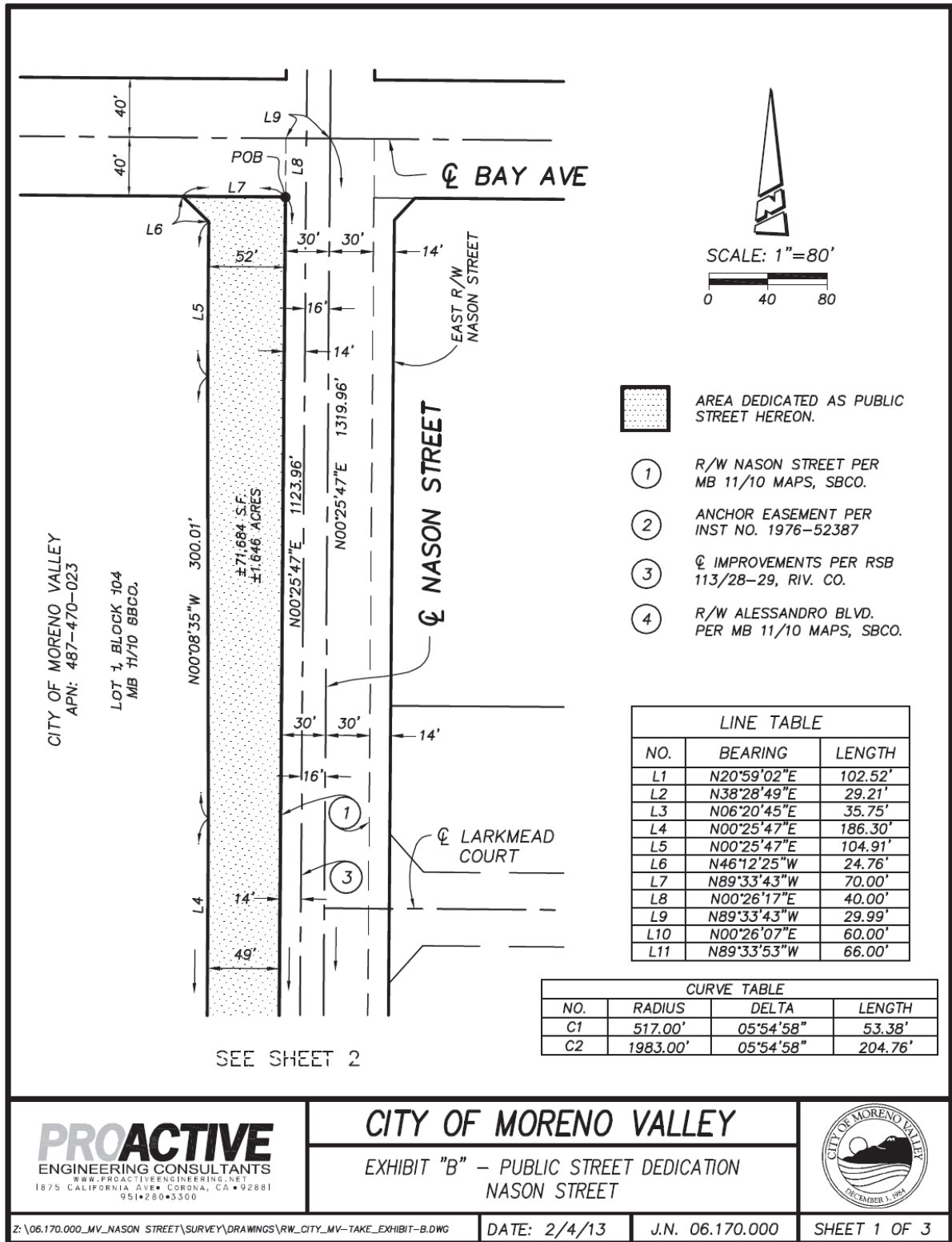

Plat Map



PROACTIVE
 ENGINEERING CONSULTANTS
WWW.PROACTIVEENGINEERING.NET
 1875 CALIFORNIA AVE • CORONA, CA • 92881
 951•280•3300

CITY OF MORENO VALLEY
 EXHIBIT "B" – PUBLIC STREET DEDICATION
 NASON STREET

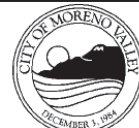

Z:\06.170.000_MV_NASON STREET\SURVEY\DRAWINGS\RW_CITY_MV-TAKE_EXHIBIT-B.DWG

DATE: 2/4/13

J.N. 06.170.000

SHEET 1 OF 3

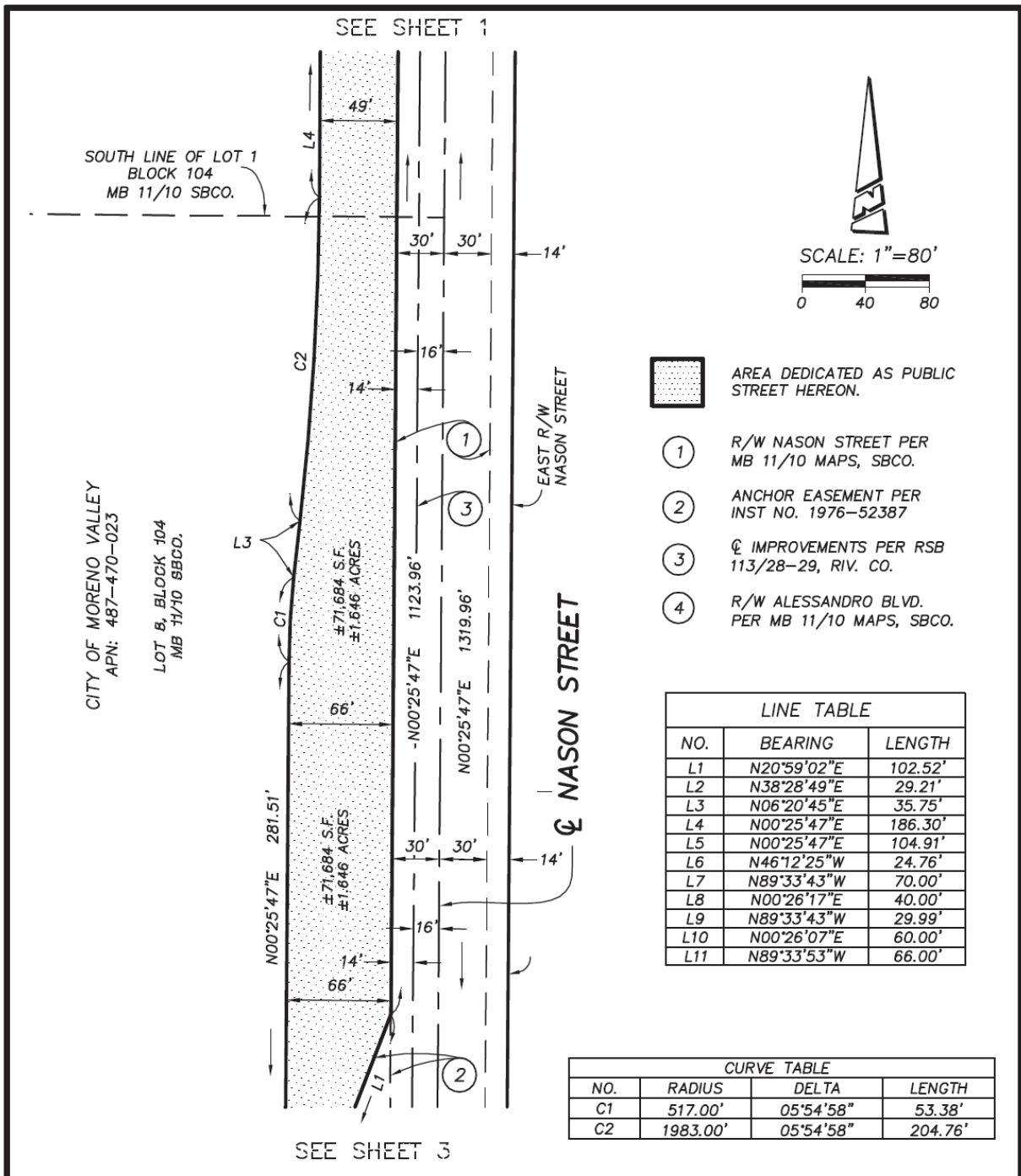

<p>PROACTIVE ENGINEERING CONSULTANTS WWW.PROACTIVEENGINEERING.NET 1875 CALIFORNIA AVE., CORONA, CA 92881 951-260-6300</p>	CITY OF MORENO VALLEY		
	EXHIBIT "B" – PUBLIC STREET DEDICATION NASON STREET		
Z:\06.170.000_MV_NASON STREET\SURVEY\DRAWINGS\RW_CITY_MV-TAKE_EXHIBIT-B.DWG	DATE: 2/4/13	J.N. 06.170.000	SHEET 2 OF 3

7
Resolution No. 2013-69
Date Adopted: August 27, 2013

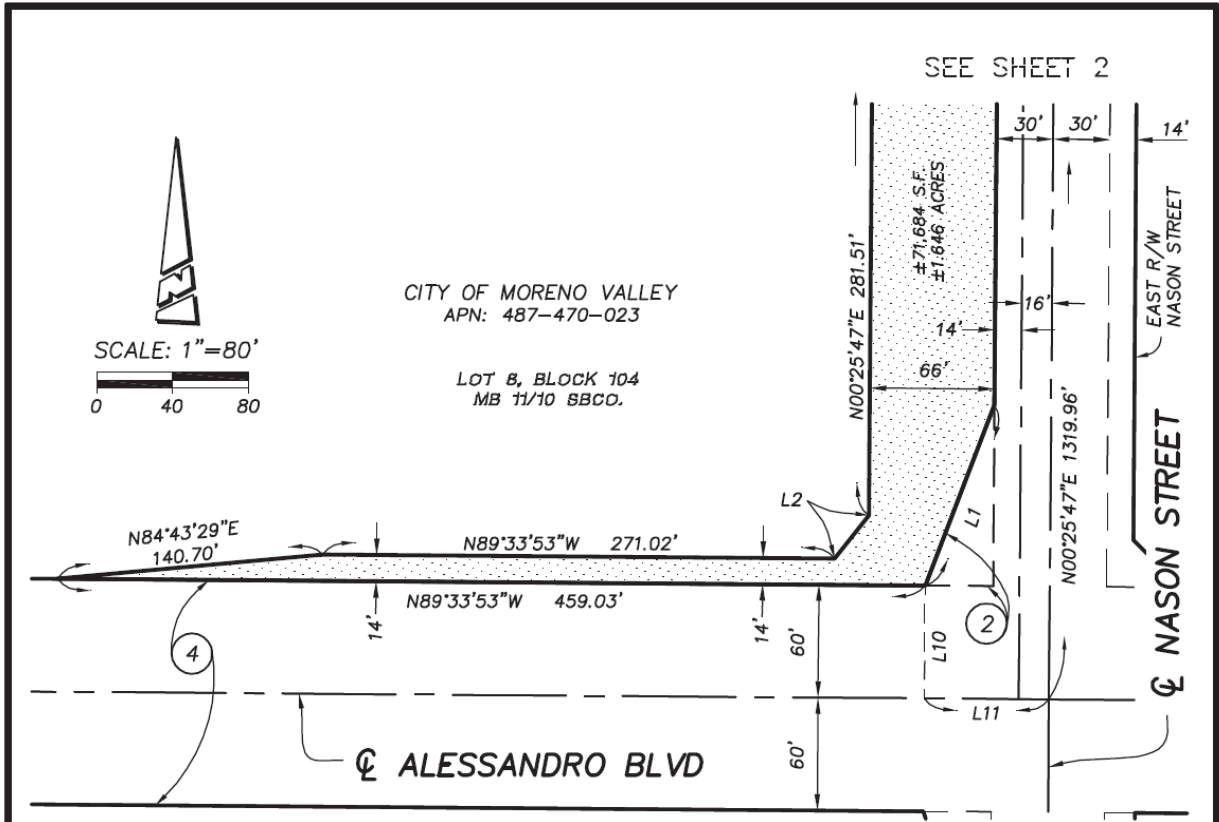

LINE TABLE		
NO.	BEARING	LENGTH
L1	N20°59'02"E	102.52'
L2	N38°28'49"E	29.21'
L3	N06°20'45"E	35.75'
L4	N00°25'47"E	186.30'
L5	N00°25'47"E	104.91'
L6	N46°12'25"W	24.76'
L7	N89°33'43"W	70.00'
L8	N00°26'17"E	40.00'
L9	N89°33'43"W	29.99'
L10	N00°26'07"E	60.00'
L11	N89°33'53"W	66.00'

CURVE TABLE			
NO.	RADIUS	DELTA	LENGTH
C1	517.00'	05°54'58"	53.38'
C2	1983.00'	05°54'58"	204.76'



AREA DEDICATED AS PUBLIC STREET HEREON.

①

R/W NASON STREET PER MB 11/10 MAPS, SBCO.

②

ANCHOR EASEMENT PER INST NO. 1976-52387

③

☉ IMPROVEMENTS PER RSB 113/28-29, RIV. CO.

④

R/W ALESSANDRO BLVD. PER MB 11/10 MAPS, SBCO.



Mark S. Brown
 MARK S. BROWN L.S. 5655
 LICENSE EXPIRES 9/30/13

PROACTIVE
 ENGINEERING CONSULTANTS
 WWW.PROACTIVEENGINEERING.NET
 1875 CALIFORNIA AVE • CORONA, CA • 92881
 951•280•3300

CITY OF MORENO VALLEY

EXHIBIT "B" – PUBLIC STREET DEDICATION
 NASON STREET

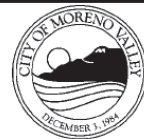

Z:\06.170.000_MV_NASON STREET\SURVEY\DRAWINGS\RW_CITY_MV-TAKE_EXHIBIT-B.DWG

DATE: 2/4/13

J.N. 06.170.000

SHEET 3 OF 3

Legal Description

POR. APN 487-470-026

IN THE CITY OF MORENO VALLEY, COUNTY OF RIVERSIDE, STATE OF CALIFORNIA BEING THAT PORTION OF LOT 8 IN BLOCK 93 OF MAP NO. 1 BEAR VALLEY AND ALESSANDRO DEVELOPMENT COMPANY AS FILED IN MAP BOOK 11, PAGE 10 THEREOF IN THE OFFICE OF THE COUNTY RECORDER OF SAN BERNARDINO COUNTY CALIFORNIA DESCRIBED AS FOLLOWS:

BEGINNING AT THE NORTHEAST CORNER OF SAID LOT 8;

THENCE SOUTH 00°25'47" WEST, ALONG THE EASTERLY LINE OF SAID LOT 8, A DISTANCE OF 619.98 FEET TO THE SOUTHEAST CORNER THEREOF;

THENCE, ALONG THE SOUTHERLY LINE OF SAID LOT 8, NORTH 89°33'43" WEST, A DISTANCE OF 70.00 FEET;

THENCE NORTH 47°03'59" EAST, A DISTANCE OF 24.76 FEET TO A POINT ON A LINE THAT IS PARALLEL WITH AND 52.00 FEET WESTERLY, AS MEASURED AT RIGHT ANGLES, FROM THE EASTERLY LINE OF SAID LOT 8;

THENCE, ALONG SAID PARALLEL LINE, NORTH 00°25'47" EAST, A DISTANCE OF 602.97 FEET TO THE NORTHERLY LINE OF SAID LOT 8;

THENCE, ALONG SAID NORTHERLY LINE, SOUTH 89°33'40" EAST, A DISTANCE OF 52.00 FEET TO THE POINT OF BEGINNING.

AREA = 32,392 SF OR 0.744 ACRES

ALSO AS SHOWN ON EXHIBIT "B" ATTACHED HERETO AND BY THIS REFERENCE MADE A PART HEREOF.

THIS DESCRIPTION WAS PREPARED BY ME OR UNDER MY DIRECTION IN CONFORMANCE WITH THE REQUIREMENTS OF THE LAND SURVEYORS ACT.

MARK S. BROWN, L.S. 5655
LICENSE EXPIRES 9/30/13

2/4/2013 J.M.
DATE PREP



Plat Map

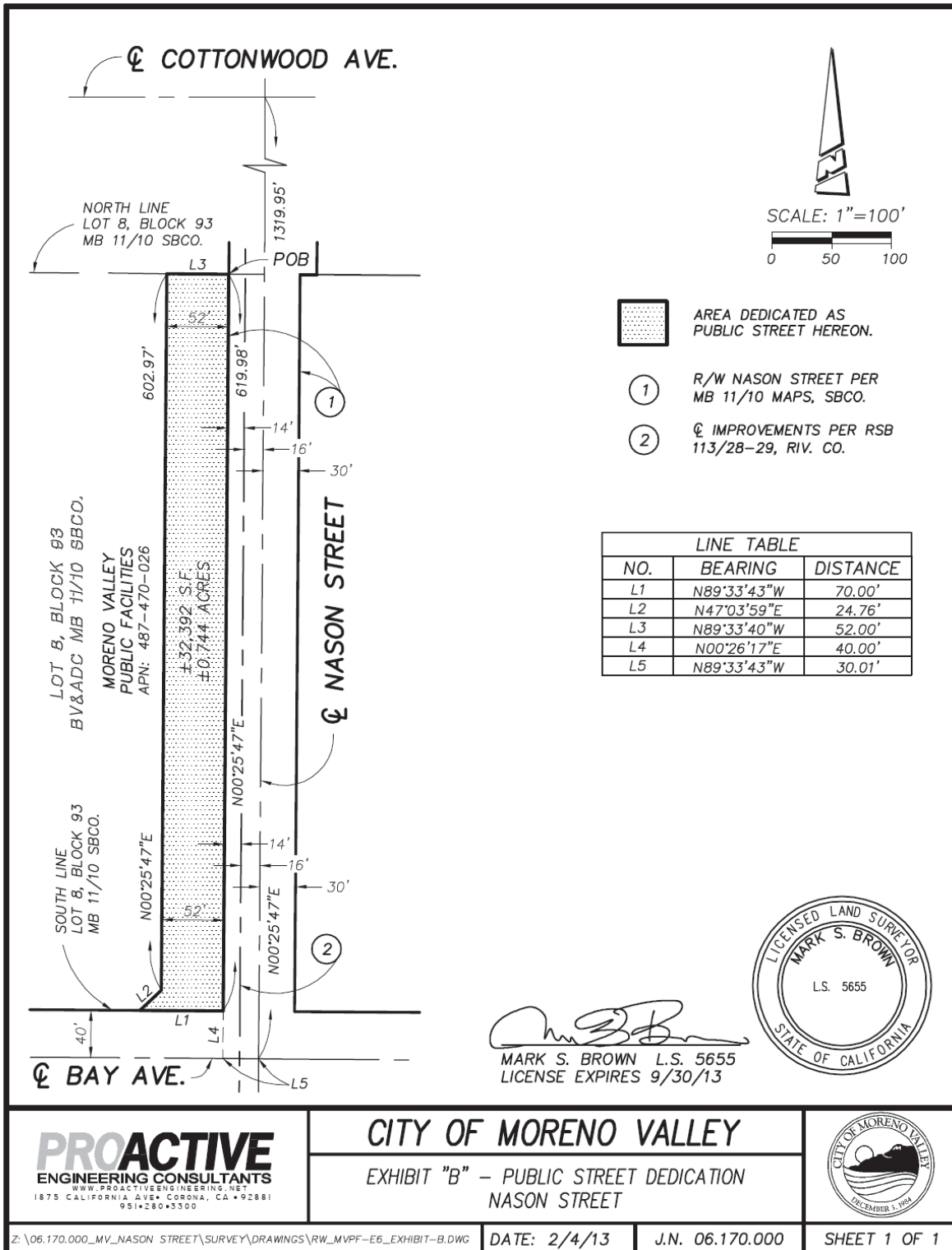

Recording requested by and when recorded, mail to:
City Clerk
City of Moreno Valley
P.O. Box 88005
Moreno Valley, CA 92552-0805

Exempt from Recording Fee
Govt. Code Sec. 6103
City of Moreno Valley

A.P.N 487-470-023

(Space above this line for Recorder's use)
DOCUMENTARY TRANSFER TAX IS NONE.
Public Agency exempt.
Revenue and Taxation Code Section 11922

EASEMENT DEED

FOR A VALUABLE CONSIDERATION, receipt of which is hereby acknowledged, the City of Moreno Valley herein called GRANTOR, hereby conveys to the CITY OF MORENO VALLEY herein called City, the right, power, privilege, and perpetual easement and right of way for public highway purposes, including public utilities, private utilities permitted by the City, and public service facilities over, under, upon, across, and within the real property in the City of Moreno Valley, County of Riverside, State of California, described on the attached Exhibit A, and as illustrated on the plat hereto and marked Exhibit B. IN WITNESS WHEREOF, this instrument has been executed this _____ day of _____, 2013.

STATE OF CALIFORNIA
County of _____
On _____ before me,
_____, Notary Public
in and for said State, personally appeared

_____,
who proved to me on the basis of satisfactory evidence, to be the person(s) whose name(s) is/are subscribed to the within instrument and acknowledged to me that he/she/they executed the same in his/her/their authorized capacity(ies), and that by his/her/their signature(s) on the instrument the person(s), or the entity upon behalf of which the person(s) acted, executed the instrument.

I certify under the PENALTY OF PERJURY under the laws of the State of California that the foregoing paragraph is true and correct.

WITNESS my hand and official seal.

Signature _____

GRANTOR:

City of Moreno Valley, a municipal corporation

By: _____

LEGAL DESCRIPTION

POR. APN 487-470-023

IN THE CITY OF MORENO VALLEY, COUNTY OF RIVERSIDE, STATE OF CALIFORNIA BEING THAT PORTION OF LOTS 1 AND 8 IN BLOCK 104 OF MAP NO. 1 BEAR VALLEY AND ALESSANDRO DEVELOPMENT COMPANY AS FILED IN MAP BOOK 11, PAGE 10 THEREOF IN THE OFFICE OF THE COUNTY RECORDER OF SAN BERNARDINO COUNTY CALIFORNIA DESCRIBED AS FOLLOWS:

BEGINNING AT THE NORTHEAST CORNER OF SAID LOT 1;

THENCE SOUTH 00°25'47" WEST ALONG THE EAST LINES OF SAID LOTS 1 AND 8, A DISTANCE OF 1123.96 FEET TO THE NORTHWESTERLY LINE OF THAT CERTAIN PARCEL CONVEYED TO THE COUNTY OF RIVERSIDE BY DOCUMENT RECORDED APRIL 20, 1976 AS INSTRUMENT NO. 1976-52387, OFFICIAL RECORDS OF SAID RIVERSIDE COUNTY;

THENCE SOUTH 20°59'02" WEST, ALONG SAID NORTHWEST LINE A DISTANCE OF 102.52 FEET TO THE SOUTH LINE OF SAID LOT 8;

THENCE NORTH 89°33'53" WEST ALONG SAID SOUTH LINE, A DISTANCE OF 459.03 FEET;

THENCE LEAVING SAID SOUTH LINE, NORTH 84°43'29" EAST A DISTANCE OF 140.70 FEET TO A LINE THAT IS PARALLEL AND 14.00 FEET NORTH AS MEASURED AT RIGHT ANGLES FROM SAID SOUTH LINE;

THENCE SOUTH 89°33'53" EAST ALONG SAID PARALLEL LINE A DISTANCE OF 271.02 FEET;

THENCE NORTH 38°28'49" EAST A DISTANCE OF 29.21 FEET TO A LINE THAT IS PARALLEL AND 66.00 FEET WEST AS MEASURED AT RIGHT ANGLES FROM SAID EAST LINE OF LOT 8;

THENCE NORTH 00°25'47" EAST ALONG SAID PARALLEL LINE A DISTANCE OF 281.51 FEET TO THE BEGINNING OF A TANGENT CURVE CONCAVE EASTERLY AND HAVING A RADIUS OF 517.00 FEET;

THENCE NORTHERLY ALONG SAID CURVE THROUGH A CENTRAL ANGLE OF 05°54'58" AN ARC DISTANCE OF 53.38 FEET;

THENCE NORTH 06°20'45" EAST 35.75 FEET TO THE BEGINNING OF A TANGENT CURVE CONCAVE WESTERLY AND HAVING A RADIUS OF 1983.00 FEET;

THENCE NORTHERLY ALONG SAID CURVE THROUGH A CENTRAL ANGLE OF 05°54'58" AN ARC DISTANCE OF 204.76 FEET TO A LINE THAT IS PARALLEL AND 49.00 FEET WEST AS MEASURED AT RIGHT ANGLES FROM SAID EAST LINE OF LOT 1;

THENCE NORTH 00°25'47" EAST ALONG SAID PARALLEL LINE A DISTANCE OF 186.30 FEET;

THENCE NORTH 00°08'35" WEST 300.01 FEET TO A LINE THAT IS PARALLEL AND 52.00 FEET WEST AS MEASURED AT RIGHT ANGLES FROM SAID EAST LINE OF LOT 1;

THENCE NORTH 00°25'47" EAST ALONG SAID PARALLEL LINE A DISTANCE OF 104.91 FEET;

THENCE NORTH 46°12'25" WEST A DISTANCE OF 24.76 FEET TO A POINT ON THE NORTH LINE OF SAID LOT 1, SAID POINT BEING 70.00 FEET WEST ALONG SAID NORTH LINE FROM SAID NORTHEAST CORNER OF LOT 1;

THENCE SOUTH 89°33'43" EAST ALONG SAID NORTH LINE OF LOT 1 A DISTANCE OF 70.00 FEET TO THE POINT OF BEGINNING;

AREA = 71,684 SF OR 1.646 ACRES

ALSO AS SHOWN ON EXHIBIT "B" ATTACHED HERETO AND BY THIS REFERENCE MADE A PART HEREOF.

THIS DESCRIPTION WAS PREPARED BY ME OR UNDER MY DIRECTION IN CONFORMANCE WITH THE REQUIREMENTS OF THE LAND SURVEYORS ACT.



MARK S. BROWN, L.S. 5655

2/4/2013
DATE

J.M.
PREP

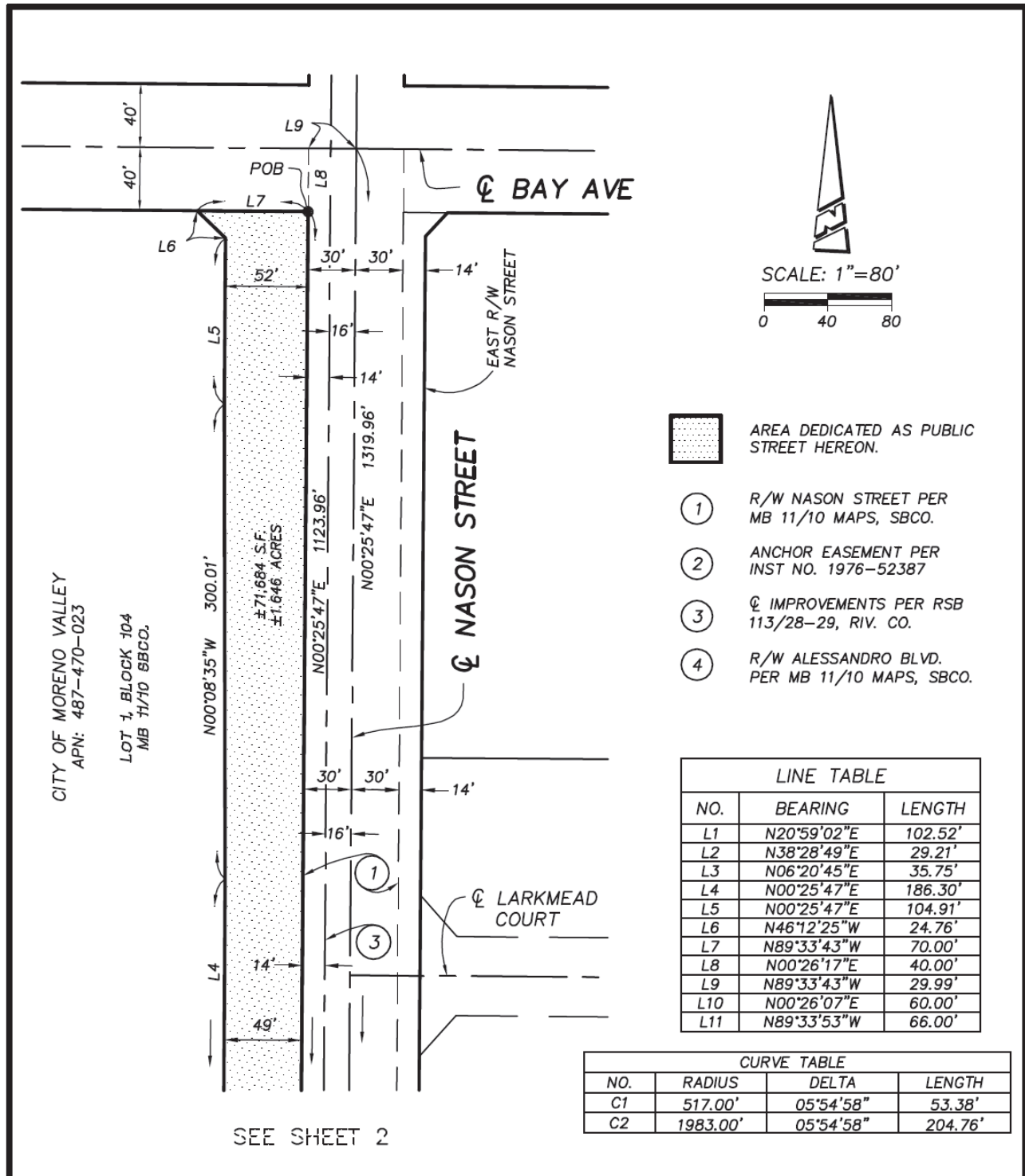



-  AREA DEDICATED AS PUBLIC STREET HEREON.
- ① R/W NASON STREET PER MB 11/10 MAPS, SBCO.
- ② ANCHOR EASEMENT PER INST NO. 1976-52387
- ③ Φ IMPROVEMENTS PER RSB 113/28-29, RIV. CO.
- ④ R/W ALESSANDRO BLVD. PER MB 11/10 MAPS, SBCO.

LINE TABLE		
NO.	BEARING	LENGTH
L1	N20°59'02"E	102.52'
L2	N38°28'49"E	29.21'
L3	N06°20'45"E	35.75'
L4	N00°25'47"E	186.30'
L5	N00°25'47"E	104.91'
L6	N46°12'25"W	24.76'
L7	N89°33'43"W	70.00'
L8	N00°26'17"E	40.00'
L9	N89°33'43"W	29.99'
L10	N00°26'07"E	60.00'
L11	N89°33'53"W	66.00'

CURVE TABLE			
NO.	RADIUS	DELTA	LENGTH
C1	517.00'	05°54'58"	53.38'
C2	1983.00'	05°54'58"	204.76'

<p>PROACTIVE ENGINEERING CONSULTANTS WWW.PROACTIVEENGINEERING.NET 1875 CALIFORNIA AVE • CORONA, CA • 92881 951•280•3300</p>	<p>CITY OF MORENO VALLEY</p> <p>EXHIBIT "B" – PUBLIC STREET DEDICATION NASON STREET</p>	
	<p>Z: \06.170.000_MV_NASON STREET\SURVEY\DRAWINGS\RW_CITY_MV-TAKE_EXHIBIT-B.DWG</p>	

SEE SHEET 1

SOUTH LINE OF LOT 1
BLOCK 104
MB 11/10 SBCO.

CITY OF MORENO VALLEY
APN: 487-470-023

LOT B, BLOCK 104
MB 11/10 SBCO.

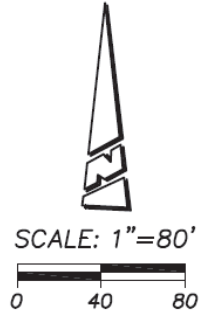
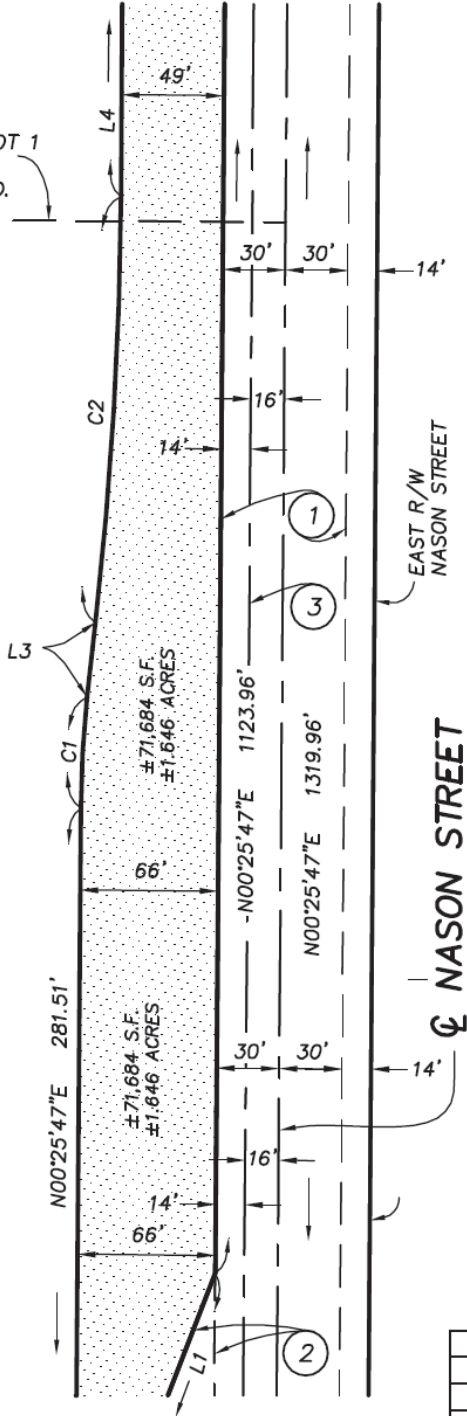

AREA DEDICATED AS PUBLIC STREET HEREON.



R/W NASON STREET PER MB 11/10 MAPS, SBCO.



ANCHOR EASEMENT PER INST NO. 1976-52387



⊕ IMPROVEMENTS PER RSB 113/28-29, RIV. CO.



R/W ALESSANDRO BLVD. PER MB 11/10 MAPS, SBCO.

LINE TABLE

NO.	BEARING	LENGTH
L1	N20°59'02"E	102.52'
L2	N38°28'49"E	29.21'
L3	N06°20'45"E	35.75'
L4	N00°25'47"E	186.30'
L5	N00°25'47"E	104.91'
L6	N46°12'25"W	24.76'
L7	N89°33'43"W	70.00'
L8	N00°26'17"E	40.00'
L9	N89°33'43"W	29.99'
L10	N00°26'07"E	60.00'
L11	N89°33'53"W	66.00'

CURVE TABLE

NO.	RADIUS	DELTA	LENGTH
C1	517.00'	05°54'58"	53.38'
C2	1983.00'	05°54'58"	204.76'

SEE SHEET 3

PROACTIVE
ENGINEERING CONSULTANTS
WWW.PROACTIVEENGINEERING.NET
1875 CALIFORNIA AVE • CORONA, CA • 92881
951-280-3300

CITY OF MORENO VALLEY

EXHIBIT "B" – PUBLIC STREET DEDICATION
NASON STREET

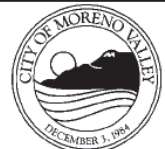

SEE SHEET 2

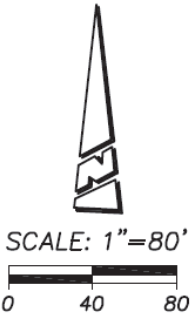

CITY OF MORENO VALLEY
APN: 487-470-023

LOT 8, BLOCK 104
MB 11/10 SBCO.

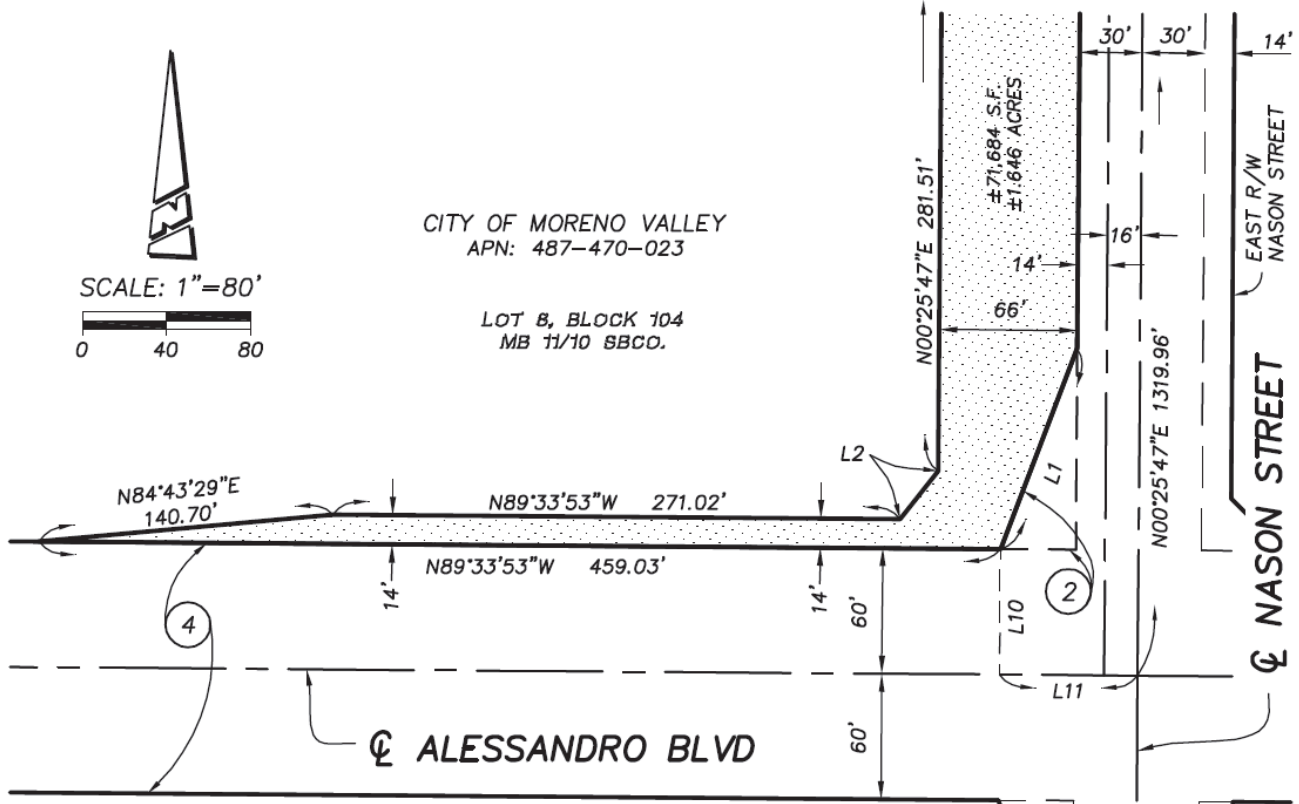

LINE TABLE		
NO.	BEARING	LENGTH
L1	N20°59'02"E	102.52'
L2	N38°28'49"E	29.21'
L3	N06°20'45"E	35.75'
L4	N00°25'47"E	186.30'
L5	N00°25'47"E	104.91'
L6	N46°12'25"W	24.76'
L7	N89°33'43"W	70.00'
L8	N00°26'17"E	40.00'
L9	N89°33'43"W	29.99'
L10	N00°26'07"E	60.00'
L11	N89°33'53"W	66.00'



AREA DEDICATED AS PUBLIC STREET HEREON.

- ① R/W NASON STREET PER MB 11/10 MAPS, SBCO.
- ② ANCHOR EASEMENT PER INST NO. 1976-52387
- ③ Φ IMPROVEMENTS PER RSB 113/28-29, RIV. CO.
- ④ R/W ALESSANDRO BLVD. PER MB 11/10 MAPS, SBCO.



Mark S. Brown
MARK S. BROWN L.S. 5655
LICENSE EXPIRES 9/30/13

CURVE TABLE			
NO.	RADIUS	DELTA	LENGTH
C1	517.00'	05°54'58"	53.38'
C2	1983.00'	05°54'58"	204.76'

PROACTIVE
ENGINEERING CONSULTANTS
WWW.PROACTIVEENGINEERING.NET
1875 CALIFORNIA AVE • CORONA, CA • 92881
951-280-3300

CITY OF MORENO VALLEY

EXHIBIT "B" - PUBLIC STREET DEDICATION
NASON STREET

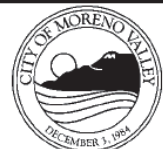

Recording requested by and when recorded, mail to:
City Clerk
City of Moreno Valley
P.O. Box 88005
Moreno Valley, CA 92552-0805

Exempt from Recording Fee
Govt. Code Sec. 6103
City of Moreno Valley

A.P.N 487-470-026

(Space above this line for Recorder's use)
DOCUMENTARY TRANSFER TAX IS NONE.
*Public Agency exempt.
Revenue and Taxation Code Section 11922*

EASEMENT DEED

FOR A VALUABLE CONSIDERATION, receipt of which is hereby acknowledged, the City of Moreno Valley herein called GRANTOR, hereby conveys to the CITY OF MORENO VALLEY herein called City, the right, power, privilege, and perpetual easement and right of way for public highway purposes, including public utilities, private utilities permitted by the City, and public service facilities over, under, upon, across, and within the real property in the City of Moreno Valley, County of Riverside, State of California, described on the attached Exhibit A, and as illustrated on the plat hereto and marked Exhibit B. IN WITNESS WHEREOF, this instrument has been executed this ____ day of _____, 2013.

STATE OF CALIFORNIA
County of _____
On _____ before me,
_____, Notary Public
in and for said State, personally appeared

_____,
who proved to me on the basis of satisfactory evidence, to be the person(s) whose name(s) is/are subscribed to the within instrument and acknowledged to me that he/she/they executed the same in his/her/their authorized capacity(ies), and that by his/her/their signature(s) on the instrument the person(s), or the entity upon behalf of which the person(s) acted, executed the instrument.

I certify under the PENALTY OF PERJURY under the laws of the State of California that the foregoing paragraph is true and correct.

WITNESS my hand and official seal.

Signature _____

GRANTOR:

City of Moreno Valley, a municipal corporation

By: _____

LEGAL DESCRIPTION

POR. APN 487-470-026

IN THE CITY OF MORENO VALLEY, COUNTY OF RIVERSIDE, STATE OF CALIFORNIA BEING THAT PORTION OF LOT 8 IN BLOCK 93 OF MAP NO. 1 BEAR VALLEY AND ALESSANDRO DEVELOPMENT COMPANY AS FILED IN MAP BOOK 11, PAGE 10 THEREOF IN THE OFFICE OF THE COUNTY RECORDER OF SAN BERNARDINO COUNTY CALIFORNIA DESCRIBED AS FOLLOWS:

BEGINNING AT THE NORTHEAST CORNER OF SAID LOT 8;

THENCE SOUTH 00°25'47" WEST, ALONG THE EASTERLY LINE OF SAID LOT 8, A DISTANCE OF 619.98 FEET TO THE SOUTHEAST CORNER THEREOF;

THENCE, ALONG THE SOUTHERLY LINE OF SAID LOT 8, NORTH 89°33'43" WEST, A DISTANCE OF 70.00 FEET;

THENCE NORTH 47°03'59" EAST, A DISTANCE OF 24.76 FEET TO A POINT ON A LINE THAT IS PARALLEL WITH AND 52.00 FEET WESTERLY, AS MEASURED AT RIGHT ANGLES, FROM THE EASTERLY LINE OF SAID LOT 8;

THENCE, ALONG SAID PARALLEL LINE, NORTH 00°25'47" EAST, A DISTANCE OF 602.97 FEET TO THE NORTHERLY LINE OF SAID LOT 8;

THENCE, ALONG SAID NORTHERLY LINE, SOUTH 89°33'40" EAST, A DISTANCE OF 52.00 FEET TO THE POINT OF BEGINNING.

AREA = 32,392 SF OR 0.744 ACRES

ALSO AS SHOWN ON EXHIBIT "B" ATTACHED HERETO AND BY THIS REFERENCE MADE A PART HEREOF.

THIS DESCRIPTION WAS PREPARED BY ME OR UNDER MY DIRECTION IN CONFORMANCE WITH THE REQUIREMENTS OF THE LAND SURVEYORS ACT.



MARK S. BROWN, L.S. 5655
LICENSE EXPIRES 9/30/13

2/4/2013
DATE

J.M.
PREP



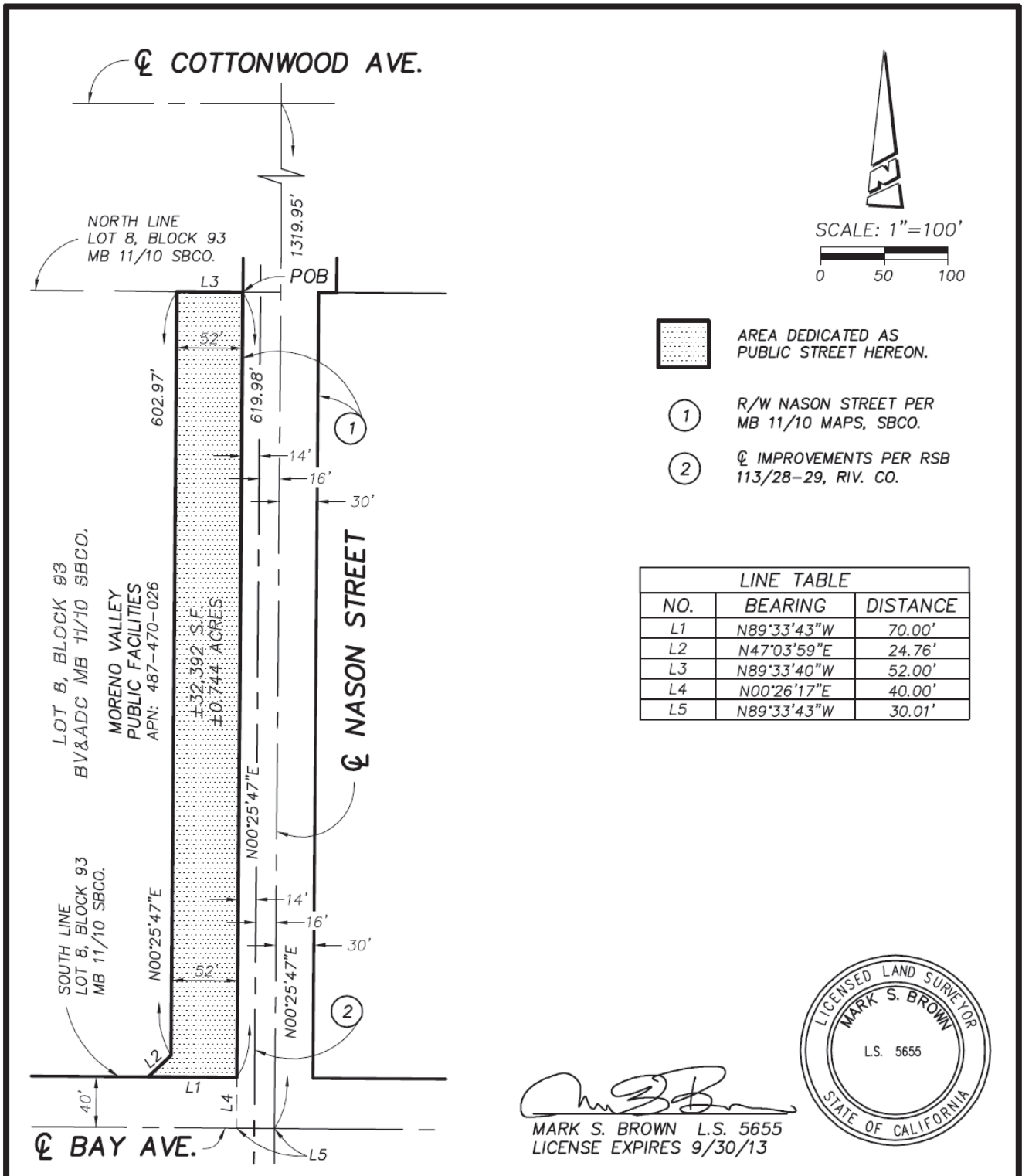

PROACTIVE
ENGINEERING CONSULTANTS
WWW.PROACTIVEENGINEERING.NET
1875 CALIFORNIA AVE • CORONA, CA • 92881
951-280-5300

CITY OF MORENO VALLEY

EXHIBIT "B" – PUBLIC STREET DEDICATION
NASON STREET

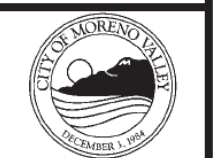

This page intentionally left blank.

RESOLUTION NO. 2013-70

A RESOLUTION OF THE CITY COUNCIL OF THE CITY OF MORENO VALLEY, CALIFORNIA, GRANTING A DRAINAGE EASEMENT ON A CITY OWNED PARCEL ON THE NORTHWEST CORNER OF ALESSANDRO BOULEVARD AND NASON STREET

WHEREAS, the City of Moreno Valley owns a vacant land parcel identified as APN 487-470-023 on the northwest corner of Alessandro Boulevard and Nason Street; and

WHEREAS, this parcel may be developed in the future; and

WHEREAS, the City of Moreno Valley wishes to grant the drainage easement to operate, maintain, and construct drainage facilities, under, over and across that certain real property, which is specifically described as:

APN 487-470-023; as described in the legal description marked Exhibit A and depicted on the plat map marked Exhibit B attached to the Resolution and incorporated herein by this reference; and

WHEREAS, the City of Moreno Valley City Council considers this grant of drainage easement to be in the best interest of the City of Moreno Valley and of the public.

NOW, THEREFORE, THE CITY COUNCIL OF THE CITY OF MORENO VALLEY, CALIFORNIA, DOES HEREBY RESOLVE AS FOLLOWS:

1. The grant of drainage easement as described above and depicted on Exhibits A and B attached to this Resolution are hereby approved.
2. The Mayor and City Clerk is hereby authorized to and directed to execute the Resolution and the Public Works Director/City Engineer is hereby authorized to and directed to execute the associated Drainage Easement on behalf of the City and record all such documents with the County Recorder.
3. This Resolution shall become effective immediately upon adoption.

BE IT FURTHER RESOLVED that the City Clerk is authorized and directed to cause this Resolution to be recorded in the Office of the Riverside County Recorder.

1
Resolution No. 2013-70
Date Adopted: August 27, 2013

APPROVED AND ADOPTED this 27th day of August, 2013.

Mayor of the City of Moreno Valley

ATTEST:

City Clerk

APPROVED AS TO FORM:

City Attorney

Resolution No. 2013-70²
Date Adopted: August 27, 2013

RESOLUTION JURAT

STATE OF CALIFORNIA)
COUNTY OF RIVERSIDE) ss.
CITY OF MORENO VALLEY)

I, Jane Halstead, City Clerk of the City of Moreno Valley, California, do hereby certify that Resolution No. 2013-70 was duly and regularly adopted by the City Council of the City of Moreno Valley at a regular meeting thereof held on the 27th day of August, 2013 by the following vote:

AYES:

NOES:

ABSENT:

ABSTAIN:

(Council Members, Mayor Pro Tem and Mayor)

CITY CLERK

(SEAL)

3
Resolution No. 2013-70
Date Adopted: August 27, 2013

Legal Description

POR. APN 487-470-023

IN THE CITY OF MORENO VALLEY, COUNTY OF RIVERSIDE, STATE OF CALIFORNIA BEING THAT PORTION OF LOT 8 IN BLOCK 104 OF MAP NO. 1 BEAR VALLEY AND ALESSANDRO DEVELOPMENT COMPANY AS FILED IN MAP BOOK 11, PAGE 10 THEREOF IN THE OFFICE OF THE COUNTY RECORDER OF SAN BERNARDINO COUNTY CALIFORNIA DESCRIBED AS FOLLOWS:

BEGINNING AT A POINT ON THE SOUTHERLY LINE OF SAID LOT 8, DISTANT WESTERLY 495.03 FEET AS MEASURED ALONG SAID LINE FROM THE SOUTHEAST CORNER THEREOF;

THENCE NORTH 89°33'53" WEST ALONG SAID SOUTHERLY LINE OF LOT 8, A DISTANCE OF 40.00 FEET;

THENCE LEAVING SAID SOUTHERLY LINE NORTH 81°08'42" EAST A DISTANCE OF 384.06 FEET TO A LINE THAT IS PARALLEL WITH AND 62.00 FEET NORTHERLY, AS MEASURED AT RIGHT ANGLES, FROM THE SOUTHERLY LINE OF SAID LOT 8;

THENCE SOUTH 89°33'53" EAST ALONG SAID PARALLEL LINE A DISTANCE OF 90.00 FEET TO A LINE THAT IS PARALLEL WITH AND 96.00 FEET WESTERLY, AS MEASURED AT RIGHT ANGLES, FROM THE CENTERLINE OF NASON STREET AS SHOWN ON SAID MAP NO. 1;

THENCE SOUTH 00°25'47" WEST ALONG SAID PARALLEL LINE A DISTANCE OF 25.00 FEET;

THENCE LEAVING SAID PARALLEL LINE SOUTH 38°28'49" WEST A DISTANCE OF 29.21 FEET TO A LINE THAT IS PARALLEL WITH AND 14.00 FEET NORTHERLY, AS MEASURED AT RIGHT ANGLES, FROM THE SOUTHERLY LINE OF SAID LOT 8;

THENCE NORTH 89°33'53" WEST ALONG SAID PARALLEL LINE A DISTANCE OF 271.02 FEET;

THENCE LEAVING SAID PARALLEL LINE SOUTH 84°43'29" WEST A DISTANCE OF 140.70 FEET TO THE POINT OF BEGINNING.

AREA = 12,097 SF OR 0.278 ACRES

ALSO AS SHOWN ON EXHIBIT "B" ATTACHED HERETO AND BY THIS REFERENCE MADE A PART HEREOF.

THIS DESCRIPTION WAS PREPARED BY ME OR UNDER MY DIRECTION IN CONFORMANCE WITH THE REQUIREMENTS OF THE LAND SURVEYORS ACT.

MARK S. BROWN, L.S. 5655

6/6/2013 J.W
DATE PREP



PLAT MAP

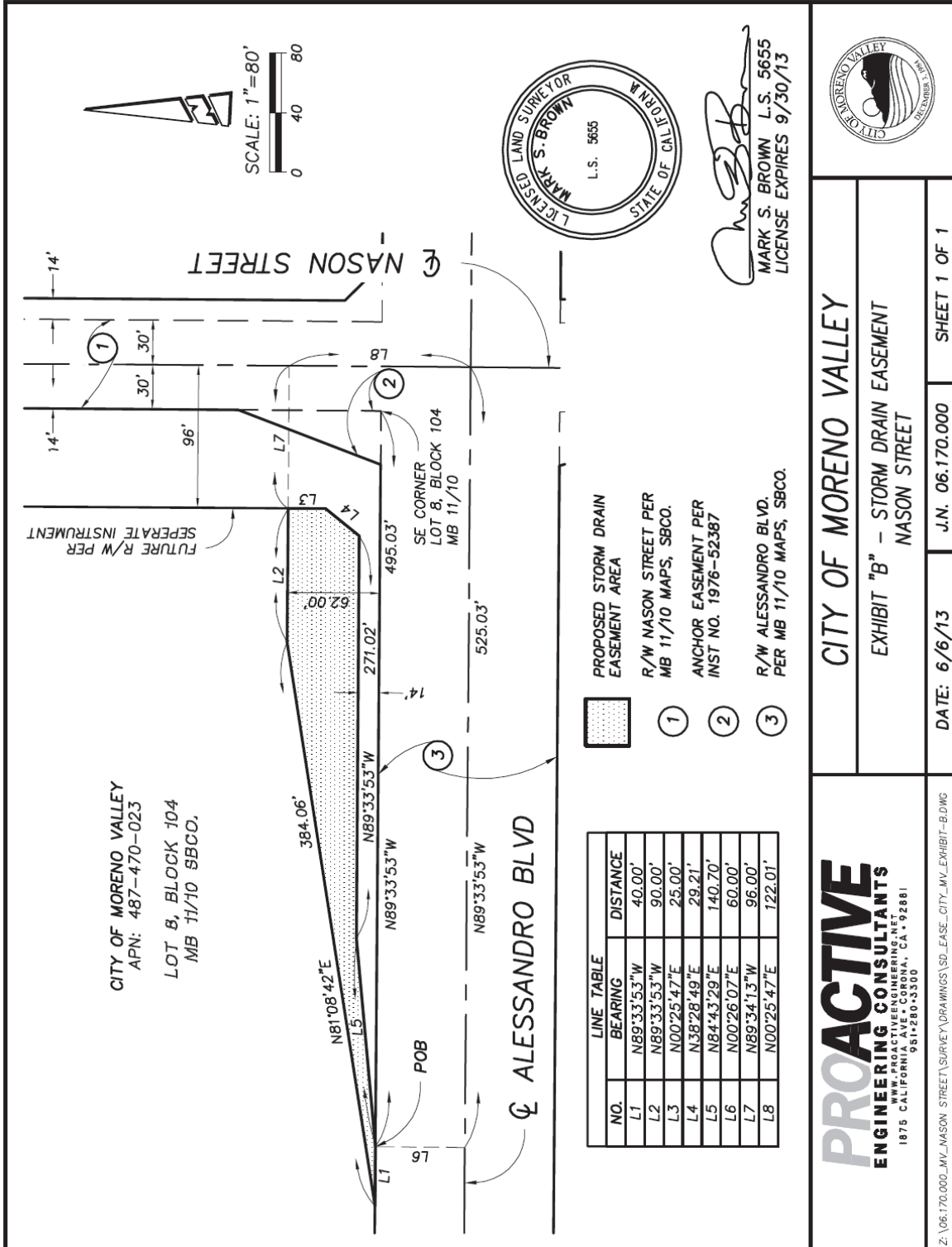

Resolution No. 2013-70
Date Adopted: August 27, 2013

This page intentionally left blank.

Recording requested by and when recorded, mail to:
City Clerk
City of Moreno Valley
P.O. Box 88005
Moreno Valley, CA 92552-0805

Exempt from Recording Fee per
Govt. Code Sec. 6103
City of Moreno Valley

A.P.N. 487-470-023

(Space above this line for Recorder's use)
DOCUMENTARY TRANSFER TAX IS NONE.
*Public Agency Exempt.
Revenue and Taxation Code Section 11922*

DRAINAGE EASEMENT

FOR VALUABLE CONSIDERATION, receipt of which is hereby acknowledged, City of Moreno Valley, herein called Grantor, hereby conveys to the CITY OF MORENO VALLEY, herein called City, the right, power, privilege, and easement to operate, maintain, and construct drainage facilities, under, over and across that certain real property located in the City of Moreno Valley, County of Riverside, State of California, which is described on the attached Exhibit "A" and as illustrated on the plat hereto and marked Exhibit "B", provided, however, that no structures for human habitation shall be constructed or maintained on said real property and that no excavation shall be conducted and no landfill placed on said real property except as may be approved, in writing, by an authorized representative of the City, as to the location and method of excavation and/or placement of landfill, as evidenced by the City's approval of a rough grade plan for said real property; reserving, however, to the Grantor, and its successors in interest, all rights and privileges as may be used and enjoyed without interfering with the use of said easement, provided, further, however, that any use of said real property shall be subject to federal and state laws relating to pollution.

STATE OF CALIFORNIA
County of _____
On _____ before me,
_____, Notary Public
in and for said State, personally appeared

_____,
who proved to me on the basis of satisfactory evidence, to be the person(s) whose name(s) is/are subscribed to the within instrument and acknowledged to me that he/she/they executed the same in his/her/their authorized capacity(ies), and that by his/her/their signature(s) on the instrument the person(s), or the entity upon behalf of which the person(s) acted, executed the instrument.

I certify under the PENALTY OF PERJURY under the laws of the State of California that the foregoing paragraph is true and correct.

WITNESS my hand and official seal.

Signature _____

GRANTOR:

City of Moreno Valley, a municipal corporation

By: _____

LEGAL DESCRIPTION

POR. APN 487-470-023

IN THE CITY OF MORENO VALLEY, COUNTY OF RIVERSIDE, STATE OF CALIFORNIA BEING THAT PORTION OF LOT 8 IN BLOCK 104 OF MAP NO. 1 BEAR VALLEY AND ALESSANDRO DEVELOPMENT COMPANY AS FILED IN MAP BOOK 11, PAGE 10 THEREOF IN THE OFFICE OF THE COUNTY RECORDER OF SAN BERNARDINO COUNTY CALIFORNIA DESCRIBED AS FOLLOWS:

BEGINNING AT A POINT ON THE SOUTHERLY LINE OF SAID LOT 8, DISTANT WESTERLY 495.03 FEET AS MEASURED ALONG SAID LINE FROM THE SOUTHEAST CORNER THEREOF;

THENCE NORTH 89°33'53" WEST ALONG SAID SOUTHERLY LINE OF LOT 8, A DISTANCE OF 40.00 FEET;

THENCE LEAVING SAID SOUTHERLY LINE NORTH 81°08'42" EAST A DISTANCE OF 384.06 FEET TO A LINE THAT IS PARALLEL WITH AND 62.00 FEET NORTHERLY, AS MEASURED AT RIGHT ANGLES, FROM THE SOUTHERLY LINE OF SAID LOT 8;

THENCE SOUTH 89°33'53" EAST ALONG SAID PARALLEL LINE A DISTANCE OF 90.00 FEET TO A LINE THAT IS PARALLEL WITH AND 96.00 FEET WESTERLY, AS MEASURED AT RIGHT ANGLES, FROM THE CENTERLINE OF NASON STREET AS SHOWN ON SAID MAP NO. 1;

THENCE SOUTH 00°25'47" WEST ALONG SAID PARALLEL LINE A DISTANCE OF 25.00 FEET;

THENCE LEAVING SAID PARALLEL LINE SOUTH 38°28'49" WEST A DISTANCE OF 29.21 FEET TO A LINE THAT IS PARALLEL WITH AND 14.00 FEET NORTHERLY, AS MEASURED AT RIGHT ANGLES, FROM THE SOUTHERLY LINE OF SAID LOT 8;

THENCE NORTH 89°33'53" WEST ALONG SAID PARALLEL LINE A DISTANCE OF 271.02 FEET;

THENCE LEAVING SAID PARALLEL LINE SOUTH 84°43'29" WEST A DISTANCE OF 140.70 FEET TO THE POINT OF BEGINNING.

AREA = 12,097 SF OR 0.278 ACRES

ALSO AS SHOWN ON EXHIBIT "B" ATTACHED HERETO AND BY THIS REFERENCE MADE A PART HEREOF.

THIS DESCRIPTION WAS PREPARED BY ME OR UNDER MY DIRECTION IN CONFORMANCE WITH THE REQUIREMENTS OF THE LAND SURVEYORS ACT.



MARK S. BROWN, L.S. 5655

6/6/2013
DATE

J.W
PREP

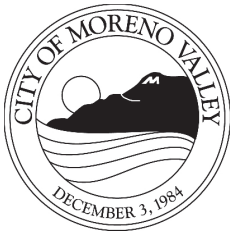

This page intentionally left blank.



APPROVALS	
BUDGET OFFICER	<i>me</i>
CITY ATTORNEY	<i>SMB</i>
CITY MANAGER	<i>d</i>

Report to City Council

TO: Mayor and City Council

FROM: Joel Ontiveros, Chief of Police

AGENDA DATE: August 27, 2013

TITLE: APPROVE BIO-TOX LABORATORIES PURCHASE ORDER FOR \$125,000

RECOMMENDED ACTION

Recommendation:

1. Authorize the Moreno Valley Police Department to execute a Purchase Order to Bio-Tox Laboratories, 1965 Chicago Ave. #C, Riverside, CA 92507, for \$125,000 (Account No. 1010-60-65-40010-625099)

BACKGROUND

The County of Riverside contracts with Bio-Tox Laboratories for toxicology testing services, to include both blood and urine. This contract details the services provided by Bio-Tox and a fee schedule. The City of Moreno Valley's Police Department has been authorized by the County of Riverside to utilize this contract as its own, which allows us to take advantage of the any negotiated discounts given to the County. Over the last few years, the Moreno Valley Police Department has had a substantial increase in the number of samples sent to Bio-Tox Laboratories for toxicology testing. This increase is partially due to the increased number of grant funded DUI enforcement operations. Additionally, over the past few years, we have had a handful of traffic officers become certified as Drug Recognition Experts (DRE) and most traffic officers have attended the Advanced Roadside Impaired Driving Enforcement (ARIDE) training sponsored by the California Highway Patrol. With deputies trained with these specialized skills, it has allowed for better recognition of drivers appearing to be driving under the influence.

DISCUSSION

Bio-Tox Laboratories collects samples of both blood and urine. A sample sent to Bio-Tox may be tested for multiple drugs and/or alcohol. Each test requested is billed

individually and invoiced on a monthly basis. Bio-Tox has the ability to track the amount of samples received by the Moreno Valley Police Department, which is detailed below, however; this is not an accurate number of tests performed only the number of blood and/or urine samples received. Alcohol tests range from \$39-\$95/per test and drug tests range from \$19-\$195/per test, per the contract. The amount of samples sent to Bio-Tox Laboratories from the Moreno Valley Police Department for the past four fiscal years are presented below.

Sample Count: Moreno Valley	FY 09-10	FY 10-11	FY 11-12	FY 12-13
Blood	413	840	964	1374
Urine	172	130	113	118
Total Samples	585	970	1077	1492

We anticipate that the charges for FY13/14 to Bio-Tox Laboratories will be approximately \$125,000, due to the increase of samples over the past few years.

ALTERNATIVES

The City Council has the following alternatives:

- 1) Authorize the Moreno Valley Police Department to execute a purchase order to Bio-Tox Laboratories for \$125,000. **Staff recommends this alternative**
- 2) Not authorize the Moreno Valley Police Department to execute a purchase order to Bio-Tox Laboratories for \$125,000. **Staff does not recommend this alternative.**

FISCAL IMPACT

The Moreno Valley Police Department budgeted \$125,000 in FY13/14 for the contract with Bio-Tox Laboratories. No appropriation is needed, as this budget was approved and appropriated to Account No. 1010-60-65-40010-625099 during the initial FY13/14 budget process.

CITY COUNCIL GOALS

To provide a safe and secure environment for people and property in the community, and provide protection for citizens who live, work and visit the City of Moreno Valley.

SUMMARY

The City Council is requested to authorize the Moreno Valley Police Department to execute a purchase order to Bio-Tox Laboratories for \$125,000.

ATTACHMENTS

Attachment 1: Professional Services Agreement for Toxicology Testing Services between the County of Riverside and Bio-Tox Laboratories

Prepared By:
Brandon Ford
Lieutenant

Department Head Approval:
Joel Ontiveros
Chief of Police

Council Action	
Approved as requested:	Referred to:
Approved as amended:	For:
Denied:	Continued until:
Other:	Hearing set for:

This page intentionally left blank.

PROFESSIONAL SERVICE AGREEMENT

for

TOXICOLOGY TESTING SERVICES

between

COUNTY OF RIVERSIDE

and

BIO-TOX LABORATORIES



TABLE OF CONTENTS

<u>SECTION HEADING</u>	<u>PAGE NUMBER</u>
1. Description of Services	3
2. Period of Performance	3
3. Compensation	3
4. Alteration or Changes to the Agreement	5
5. Termination	5
6. Ownership/Use of Contract Materials and Products	6
7. Conduct of Contractor	6
8. Inspection of Service: Quality Control/Assurance	6
9. Independent Contractor	7
10. Subcontract for Work or Services.....	8
11. Disputes	8
12. Licensing and Permits	8
13. Use by Other Political Entities	8
14. Non-Discrimination	9
15. Records and Documents	9
16. Confidentiality	9
17. Administration/Contract Liaison	10
18. Notices.....	10
19. Force Majeure.....	10
20. EDD Reporting Requirements.....	10
21. Hold Harmless/Indemnification.....	11
22. Insurance	12
23. General	15
Exhibit A-Scope of Service	17
Exhibit B- Payment Provisions.....	20

This Agreement, made and entered into this 23 day of April, 2013, by and between Bio-Tox Laboratories, (herein referred to as "CONTRACTOR"), and the COUNTY OF RIVERSIDE, a political subdivision of the State of California, (herein referred to as "COUNTY"). The parties agree as follows:

1. Description of Services

1.1 CONTRACTOR shall provide all services as outlined and specified in Exhibit A, Scope of Services, consisting of 3 pages at the prices stated in Exhibit B, Payment Provisions (4 pages).

1.2 CONTRACTOR represents that it has the skills, experience, and knowledge necessary to fully and adequately perform under this Agreement and the COUNTY relies upon this representation. CONTRACTOR shall perform to the satisfaction of the COUNTY and in conformance to and consistent with the highest standards of firms/professionals in the same discipline in the State of California.

1.3 CONTRACTOR affirms this it is fully apprised of all of the work to be performed under this Agreement; and the CONTRACTOR agrees it can properly perform this work at the prices stated in Exhibit I. CONTRACTOR is not to perform services or provide products outside of the Agreement.

1.4 Acceptance by the COUNTY of the CONTRACTOR's performance under this Agreement does not operate as a release of CONTRACTOR's responsibility for full compliance with the terms of this Agreement.

2. Period of Performance

2.1 This Agreement shall be effective upon signature of this Agreement by both parties and continue in effect through April 22, 2014, with the option to renew for four (4) additional years, renewable in one year increments by written amendment, unless terminated earlier. CONTRACTOR shall commence performance upon signature of this Agreement by both parties and shall diligently and continuously perform thereafter.

3. Compensation

3.1 The COUNTY shall pay the CONTRACTOR for services performed, products provided and expenses incurred in accordance with the terms of Exhibit B, Payment Provisions. Maximum payments by COUNTY to CONTRACTOR shall not exceed \$510,000.00 annually including all expenses. The COUNTY is not responsible for any fees or costs incurred above or beyond the contracted amount and shall have no obligation to purchase any specified amount of services or products. Unless otherwise specifically stated in Exhibit B, COUNTY shall not be responsible for payment of any of CONTRACTOR's expenses related to this Agreement.

3.2 No price increases will be permitted during the first year of this Agreement. All price decreases (for example, if CONTRACTOR offers lower prices to another governmental entity) will automatically be extended to the COUNTY. The COUNTY requires written proof satisfactory to COUNTY of cost increases prior to any approved price adjustment. After the first year of the award, a minimum of 30-days advance notice in writing is required to be considered and approved by COUNTY. No retroactive price adjustments will be considered. Any price increases must be stated in a written amendment to this Agreement. The net dollar amount of profit will remain firm during the period of the Agreement. Annual increases shall not exceed the Consumer Price Index- All Consumers, All Items - Greater Los Angeles, Riverside and Orange County areas and be subject to satisfactory performance review by the COUNTY and approved (if needed) for budget funding by the Board of Supervisors.

3.3 CONTRACTOR shall be paid only in accordance with an invoice submitted to COUNTY by CONTRACTOR within fifteen (15) days from the last day of each calendar month, and COUNTY shall pay the invoice within thirty (30) working days from the date of receipt of the invoice. Payment shall be made to CONTRACTOR only after services have been rendered or delivery of materials or products, and acceptance has been made by COUNTY. Prepare invoices in duplicate. For this Agreement, send the original and duplicate copies of invoices to:

Riverside County Sheriff Department, Fiscal Department
4080 Lemon Street
Riverside, CA 92502

- a) Each invoice shall contain a minimum of the following information: invoice number and date; remittance address; bill-to and ship-to addresses of ordering department/division; Agreement number SHARC-96148-001-3/14; quantities; item descriptions, unit prices, extensions, sales/use tax if applicable, and an invoice total.
- b) Invoices shall be rendered monthly in arrears.

3.4 The COUNTY obligation for payment of this Agreement beyond the current fiscal year end is contingent upon and limited by the availability of COUNTY funding from which payment can be made. No legal liability on the part of the COUNTY shall arise for payment beyond June 30 of each calendar year unless funds are made available for such payment. In the event that such funds are not forthcoming for any reason, COUNTY shall immediately notify CONTRACTOR in writing; and this Agreement shall be deemed terminated, have no further force, and effect.

4. Alteration or Changes to the Agreement

4.1 The Board of Supervisors and the COUNTY Purchasing Agent and/or his designee is the only authorized COUNTY representatives who may at any time, by written order, alter this Agreement. If any such alteration causes an increase or decrease in the cost of, or the time required for the performance under this Agreement, an equitable adjustment shall be made in the Agreement price or delivery schedule, or both, and the Agreement shall be modified by written amendment accordingly.

4.2 Any claim by the CONTRACTOR for additional payment related to this Agreement shall be made in writing by the CONTRACTOR within 30 days of when the CONTRACTOR has or should have notice of any actual or claimed change in the work, which results in additional and unanticipated cost to the CONTRACTOR. If the COUNTY Purchasing Agent decides that the facts provide sufficient justification, he may authorize additional payment to the CONTRACTOR pursuant to the claim. Nothing in this section shall excuse the CONTRACTOR from proceeding with performance of the Agreement even if there has been a change.

5. Termination

5.1 COUNTY may terminate this Agreement without cause upon 30 days written notice served upon the CONTRACTOR stating the extent and effective date of termination.

5.2 COUNTY may, upon five (5) days written notice, terminate this Agreement for CONTRACTOR's default, if CONTRACTOR refuses or fails to comply with the terms of this Agreement or fails to make progress to endanger performance and does not immediately cure such failure. In the event of such termination, the COUNTY may proceed with the work in any manner deemed proper by COUNTY.

5.3 After receipt of the notice of termination, CONTRACTOR shall:

- (a) Stop all work under this Agreement on the date specified in the notice of termination; and
- (b) Transfer to COUNTY and deliver in the manner as directed by COUNTY any materials, reports or other products, which, if the Agreement had been completed or continued, would have been required to be furnished to COUNTY.

5.4 After termination, COUNTY shall make payment only for CONTRACTOR's performance up to the date of termination in accordance with this Agreement and at the rates set forth in Exhibit B.

5.5 CONTRACTOR's rights under this Agreement shall terminate (except for fees accrued prior to the date of termination) upon dishonesty or a willful or material breach of this Agreement by CONTRACTOR; or in the event of CONTRACTOR's unwillingness or inability for any reason whatsoever

to perform the terms of this Agreement. In such event, CONTRACTOR shall not be entitled to any further compensation under this Agreement.

5.6 The rights and remedies of COUNTY provided in this section shall not be exclusive and are in addition to any other rights and remedies provided by law or this Agreement.

6. Ownership/Use of Contract Materials and Products

The CONTRACTOR agrees that all materials, reports or products in any form, including electronic, created by CONTRACTOR for which CONTRACTOR has been compensated by COUNTY pursuant to this Agreement shall be the sole property of the COUNTY; and may be used by the COUNTY for any purpose COUNTY deems to be appropriate, including, but not limit to, duplication and/or distribution within the COUNTY or to third parties. CONTRACTOR agrees not to release or circulate in whole or part such materials, reports, or products without prior written authorization of the COUNTY.

7. Conduct of Contractor

7.1 The CONTRACTOR covenants that it presently has no interest, including, but not limited to, other projects or contracts, and shall not acquire any such interest, direct or indirect, which would conflict in any manner or degree with CONTRACTOR's performance under this Agreement. The CONTRACTOR further covenants that no person or subcontractor having any such interest shall be employed or retained by CONTRACTOR under this Agreement. The CONTRACTOR agrees to inform the COUNTY of all the CONTRACTOR's interests, if any, which are or may be perceived as incompatible with the COUNTY's interests.

7.2 The CONTRACTOR shall not, under circumstances which could be interpreted as an attempt to influence the recipient in the conduct of his/her duties, accept any gratuity or special favor from individuals or firms with whom the CONTRACTOR is doing business or proposing to do business, in accomplishing the work under this Agreement.

7.3 The CONTRACTOR or its employees shall not offer gifts, gratuity, favors, and entertainment directly or indirectly to COUNTY employees.

8. Inspection of Service; Quality Control/Assurance

8.1 All performance (which includes services, workmanship, materials, supplies and equipment furnished or utilized in the performance of this Agreement) shall be subject to inspection and test by the COUNTY or other regulatory agencies at all times. The CONTRACTOR shall provide adequate cooperation to any inspector or other COUNTY representative to permit him/her to determine the

CONTRACTOR's conformity with the terms of this Agreement. If any services performed or products provided by CONTRACTOR are not in conformance with the terms of this Agreement, the COUNTY shall have the right to require the CONTRACTOR to perform the services or provide the products in conformance with the terms of the Agreement at no additional cost to the COUNTY. When the services to be performed or the products to be provided are of such nature that the difference cannot be corrected, the COUNTY shall have the right to: (1) require the CONTRACTOR immediately to take all necessary steps to ensure future performance in conformity with the terms of the Agreement; and/or (2) reduce the Agreement price to reflect the reduced value of the services performed or products provided. The COUNTY may also terminate this Agreement for default and charge to CONTRACTOR any costs incurred by the COUNTY because of the CONTRACTOR's failure to perform.

8.2 CONTRACTOR shall establish adequate procedures for self-monitoring and quality control and assurance to ensure proper performance under this Agreement; and shall permit a COUNTY representative or other regulatory official to monitor, assess, or evaluate CONTRACTOR's performance under this Agreement at any time upon reasonable notice to CONTRACTOR.

9. **Independent Contractor**

The CONTRACTOR is, for purposes relating to this Agreement, an independent contractor and shall not be deemed an employee of the COUNTY. It is expressly understood and agreed that the CONTRACTOR (including its employees, agents, and subcontractors) shall in no event be entitled to any benefits to which COUNTY employees are entitled, including but not limited to overtime, any retirement benefits, worker's compensation benefits, and injury leave or other leave benefits. There shall be no employer-employee relationship between the parties; and CONTRACTOR shall hold COUNTY harmless from any and all claims that may be made against COUNTY based upon any contention by a third party that an employer-employee relationship exists by reason of this Agreement. It is further understood and agreed by the parties that CONTRACTOR in the performance of this Agreement is subject to the control or direction of COUNTY merely as to the results to be accomplished and not as to the means and methods for accomplishing the results.

10. Subcontract for Work or Services

No contract shall be made by the CONTRACTOR with any other party for furnishing any of the work or services under this Agreement without the prior written approval of the COUNTY; but this provision shall not require the approval of contracts of employment between the CONTRACTOR and personnel assigned under this Agreement, or for parties named in the proposal and agreed to under this Agreement.

11. Disputes

11.1 The parties shall attempt to resolve any disputes amicably at the working level. If that is not successful, the dispute shall be referred to the senior management of the parties. Any dispute relating to this Agreement, which is not resolved by the parties, shall be decided by the COUNTY's Purchasing Department's Compliance Contract Officer who shall furnish the decision in writing. The decision of the COUNTY's Compliance Contract Officer shall be final and conclusive unless determined by a court of competent jurisdiction to have been fraudulent, capricious, arbitrary, or so grossly erroneous as necessarily to imply bad faith. The CONTRACTOR shall proceed diligently with the performance of this Agreement pending the resolution of a dispute.

11.2 Prior to the filing of any legal action related to this Agreement, the parties shall be obligated to attend a mediation session in Riverside County before a neutral third party mediator. A second mediation session shall be required if the first session is not successful. The parties shall share the cost of the mediations.

12. Licensing and Permits

CONTRACTOR shall comply with all State or other licensing requirements, including but not limited to the provisions of Chapter 9 of Division 3 of the Business and Professions Code. All licensing requirements shall be met at the time proposals are submitted to the COUNTY. CONTRACTOR warrants that it has all necessary permits, approvals, certificates, waivers and exemptions necessary for performance of this Agreement as required by the laws and regulations of the United States, the State of California, the County of Riverside and all other governmental agencies with jurisdiction, and shall maintain these throughout the term of this Agreement.

13. Use By Other Political Entities

The CONTRACTOR agrees to extend the same pricing, terms, and conditions as stated in this Agreement to the Riverside County Sheriff's Department, Riverside Police Department and Corona Police

Department only. It is understood that each entity shall make purchases in their own name, make direct payment, and be liable directly to the CONTRACTOR. COUNTY shall in no way be responsible to CONTRACTOR for Riverside Police Department or Corona Police Department purchases.

14. Non-Discrimination

CONTRACTOR shall not be discriminate in the provision of services, allocation of benefits, accommodation in facilities, or employment of personnel on the basis of ethnic group identification, race, religious creed, color, national origin, ancestry, physical handicap, medical condition, marital status or sex in the performance of this Agreement; and, to the extent they shall be found to be applicable hereto, shall comply with the provisions of the California Fair Employment and Housing Act (Gov. Code 12900 et. seq), the Federal Civil Rights Act of 1964 (P.L. 88-352), the Americans with Disabilities Act of 1990 (42 U.S.C. S1210 et seq.) and all other applicable laws or regulations.

15. Records and Documents

CONTRACTOR shall make available, upon written request by any duly authorized Federal, State, or COUNTY agency, a copy of this Agreement and such books, documents and records as are necessary to certify the nature and extent of the CONTRACTOR's costs related to this Agreement. All such books, documents and records shall be maintained by CONTRACTOR for at least five years following termination of this Agreement and be available for audit by the COUNTY. CONTRACTOR shall provide to the COUNTY reports and information related to this Agreement as requested by COUNTY.

16. Confidentiality

16.1 The CONTRACTOR shall not use for personal gain or make other improper use of privileged or confidential information which is acquired in connection with this Agreement. The term "privileged or confidential information" includes but is not limited to: unpublished or sensitive technological or scientific information; medical, personnel, or security records; anticipated material requirements or pricing/purchasing actions; COUNTY information or data which is not subject to public disclosure; COUNTY operational procedures; and knowledge of selection of contractors, subcontractors or suppliers in advance of official announcement.

16.2 The CONTRACTOR shall protect from unauthorized disclosure names and other identifying information concerning persons receiving services pursuant to this Agreement, except for general statistical information not identifying any person. The CONTRACTOR shall not use such information for any purpose other than carrying out the CONTRACTOR's obligations under this Agreement. The CONTRACTOR shall

promptly transmit to the COUNTY all third party requests for disclosure of such information. The CONTRACTOR shall not disclose, except as otherwise specifically permitted by this Agreement or authorized in advance in writing by the COUNTY, any such information to anyone other than the COUNTY. For purposes of this paragraph, identity shall include, but not be limited to, name, identifying number, symbol, or other identifying particular assigned to the individual, such as finger or voice print or a photograph.

17. Administration/Contract Liaison

The COUNTY Purchasing Agent, or designee, shall administer this Agreement on behalf of the COUNTY. The Purchasing Department is to serve as the liaison with CONTRACTOR in connection with this Agreement.

18. Notices

All correspondence and notices required or contemplated by this Agreement shall be delivered to the respective parties at the addresses set forth below and are deemed submitted two days after their deposit in the United States mail, postage prepaid:

COUNTY OF RIVERSIDE

Purchasing and Fleet Services
Attn: James P. Hewett JD/MBA
2980 Washington Street
Riverside, CA 92504

CONTRACTOR

Bio-Tox Laboratories
Attn: Tracey Stangarone
1965 Chicago Ave. #C
Riverside, CA 92507

19. Force Majeure

If either party is unable to comply with any provision of this Agreement due to causes beyond its reasonable control, and which could not have been reasonably anticipated, such as acts of God, acts of war, civil disorders, or other similar acts, such party shall not be held liable for such failure to comply.

20. EDD Reporting Requirements

In order to comply with child support enforcement requirements of the State of California, the COUNTY may be required to submit a Report of Independent Contractor(s) form DE 542 to the Employment Development Department. The CONTRACTOR agrees to furnish the required data and certifications to the COUNTY within 10 days of notification of award of Agreement when required by the EDD. This data will be transmitted to governmental agencies charged with the establishment and enforcement of child support orders. Failure of the CONTRACTOR to timely submit the data and/or certificates required may result in the contract being awarded to another contractor. In the event a contract

has been issued, failure of the CONTRACTOR to comply with all federal and state reporting requirements for child support enforcement or to comply with all lawfully served Wage and Earnings Assignments Orders and Notices of Assignment shall constitute a material breach of Agreement. If CONTRACTOR has any questions concerning this reporting requirement, please call (916) 657-0529. CONTRACTOR should also contact its local Employment Tax Customer Service Office listed in the telephone directory in the State Government section under "Employment Development Department" or access their Internet site at www.edd.ca.gov.

21. Hold Harmless/Indemnification

21.1 CONTRACTOR shall indemnify and hold harmless the County of Riverside, its Agencies, Districts, Special Districts and Departments, their respective directors, officers, Board of Supervisors, elected and appointed officials, employees, agents and representatives (individually and collectively hereinafter referred to as Indemnitees) from any liability whatsoever, based or asserted upon any services of CONTRACTOR, its officers, employees, subcontractors, agents or representatives arising out of or in any way relating to this Agreement, including but not limited to property damage, bodily injury, or death or any other element of any kind or nature whatsoever arising from the performance of CONTRACTOR, its officers, employees, subcontractors, agents or representatives Indemnitors from this Agreement. CONTRACTOR shall defend, at its sole expense, all costs, and fees including, but not limited, to attorney fees, cost of investigation, defense and settlements or awards, the Indemnitees in any claim or action based upon such alleged acts or omissions.

21.2 With respect to any action or claim subject to indemnification herein by CONTRACTOR, CONTRACTOR shall, at their sole cost, have the right to use counsel of their own choice and shall have the right to adjust, settle, or compromise any such action or claim without the prior consent of COUNTY; provided, however, that any such adjustment, settlement or compromise in no manner whatsoever limits or circumscribes CONTRACTOR'S indemnification to Indemnitees as set forth herein. CONTRACTOR'S obligation hereunder shall be satisfied when CONTRACTOR has provided to COUNTY the appropriate form of dismissal relieving COUNTY from any liability for the action or claim involved.

21.3 The specified insurance limits required in this Agreement shall in no way limit or circumscribe CONTRACTOR'S obligations to indemnify and hold harmless the Indemnitees herein from third party claims.

21.4 In the event there is conflict between this clause and California Civil Code Section 2782, this clause shall be interpreted to comply with Civil Code 2782. Such interpretation shall not relieve the CONTRACTOR from indemnifying the Indemnitees to the fullest extent allowed by law.

21.5 CONTRACTOR's indemnification obligations shall also apply to any action or claim regarding actual or alleged intellectual property infringement related to any material or product provided to COUNTY pursuant to this Agreement. In the event of any such action or claim, CONTRACTOR shall provide immediate notice to COUNTY of the action or claim. CONTRACTOR may defend or settle the action or claim as CONTRACTOR deems appropriate; however, CONTRACTOR shall be required to obtain for COUNTY the right to continue to use the material or product (or a similar non-infringing material or product with the same function) on terms identical to those stated in this Agreement.

22. Insurance

22.1 Without limiting or diminishing the CONTRACTOR'S obligation to indemnify or hold the COUNTY harmless, CONTRACTOR shall procure and maintain or cause to be maintained, at its sole cost and expense, the following insurance coverage's during the term of this Agreement. As respects to the insurance section only, the COUNTY herein refers to the County of Riverside, its Agencies, Districts, Special Districts, and Departments, their respective directors, officers, Board of Supervisors, employees, elected or appointed officials, agents, or representatives as Additional Insureds.

22.2 Workers' Compensation: If the CONTRACTOR has employees as defined by the State of California, the CONTRACTOR shall maintain statutory Workers' Compensation Insurance (Coverage A) as prescribed by the laws of the State of California. Policy shall include Employers' Liability (Coverage B) including Occupational Disease with limits not less than \$1,000,000 per person per accident. The policy shall be endorsed to waive subrogation in favor of the County of Riverside.

22.3 Commercial General Liability: Commercial General Liability insurance coverage, including but not limited to, premises liability, unmodified contractual liability, products and completed operations liability, personal and advertising injury, and cross liability coverage, covering claims which may arise from or out of CONTRACTOR'S performance of its obligations hereunder. Policy shall name the COUNTY as Additional Insured. Policy's limit of liability shall not be less than \$1,000,000 per occurrence combined single limit. If such insurance contains a general aggregate limit, it shall apply separately to this agreement or be no less than two (2) times the occurrence limit.

22.4 Vehicle Liability: If vehicles or mobile equipment are used in the performance of the obligations under this Agreement, then CONTRACTOR shall maintain liability insurance for all owned, non-owned, or hired vehicles so used in an amount not less than \$1,000,000 per occurrence combined single

limit. If such insurance contains a general aggregate limit, it shall apply separately to this agreement or be no less than two (2) times the occurrence limit. Policy shall name the COUNTY as Additional Insureds.

22.5 Professional Liability: Contractor shall maintain Professional Liability Insurance providing coverage for the Contractor's performance of work included within this Agreement, with a limit of liability of not less than \$1,000,000 per occurrence and \$2,000,000 annual aggregate. If Contractor's Professional Liability Insurance is written on a claims made basis rather than an occurrence basis, such insurance shall continue through the term of this Agreement and CONTRACTOR shall purchase at his sole expense either 1) an Extended Reporting Endorsement (also, known as Tail Coverage); or 2) Prior Dates Coverage from new insurer with a retroactive date back to the date of, or prior to, the inception of this Agreement; or 3) demonstrate through Certificates of Insurance that CONTRACTOR has Maintained continuous coverage with the same or original insurer. Coverage provided under items; 1), 2), or 3) will continue as long as the law allows.

22.6 General Insurance Provisions - All lines:

1) Any insurance carrier providing insurance coverage hereunder shall be admitted to the State of California and have an A M BEST rating of not less than A: VIII (A:8) unless such requirements are waived, in writing, by the County Risk Manager. If the County's Risk Manager waives a requirement for a particular insurer such waiver is only valid for that specific insurer and only for one policy term.

2) The CONTRACTOR must declare its insurance self-insured retention for each coverage required herein. If any such self-insured retention exceeds \$500,000 per occurrence each such retention shall have the prior written consent of the County Risk Manager before the commencement of operations under this Agreement. Upon notification of self-insured retention unacceptable to the COUNTY, and at the election of the County's Risk Manager, CONTRACTOR'S carriers shall either; 1) reduce or eliminate such self-insured retention as respects this Agreement with the COUNTY, or 2) procure a bond which guarantees payment of losses and related investigations, claims administration, and defense costs and expenses.

3) CONTRACTOR shall cause CONTRACTOR'S insurance carrier(s) to furnish the County of Riverside with either 1) a properly executed original Certificate(s) of Insurance and certified original copies of Endorsements effecting coverage as required herein, and 2) if requested to do so orally or in writing by the County Risk Manager, provide original Certified copies of policies including all Endorsements and all attachments thereto, showing such insurance is in full force and effect. Further, said Certificate(s) and policies of insurance shall contain the covenant of the insurance carrier(s) that thirty (30) days written notice shall be given to the County of Riverside prior to any material modification, cancellation, expiration or reduction in coverage of such insurance. In the event of a material modification, cancellation, expiration, or

reduction in coverage, this Agreement shall terminate forthwith, unless the County of Riverside receives, prior to such effective date, another properly executed original Certificate of Insurance and original copies of endorsements or certified original policies, including all endorsements and attachments thereto evidencing coverage's set forth herein and the insurance required herein is in full force and effect. *CONTRACTOR shall not commence operations until the COUNTY has been furnished original Certificate (s) of Insurance and certified original copies of endorsements and if requested, certified original policies of insurance including all endorsements and any and all other attachments as required in this Section. An individual authorized by the insurance carrier to do so on its behalf shall sign the original endorsements for each policy and the Certificate of Insurance.*

4) It is understood and agreed to by the parties hereto that the CONTRACTOR'S insurance shall be construed as primary insurance, and the COUNTY'S insurance and/or deductibles and/or self-insured retention's or self-insured programs shall not be construed as contributory.

5) If, during the term of this Agreement or any extension thereof, there is a material change in the scope of services; or, there is a material change in the equipment to be used in the performance of the scope of work; or, the term of this Agreement, including any extensions thereof, exceeds five (5) years; the COUNTY reserves the right to adjust the types of insurance and the monetary limits of liability required under this Agreement, if in the County Risk Manager's reasonable judgment, the amount or type of insurance carried by the CONTRACTOR has become inadequate.

6) CONTRACTOR shall pass down the insurance obligations contained herein to all tiers of subcontractors working under this Agreement.

7) The insurance requirements contained in this Agreement may be met with a program(s) of self-insurance acceptable to the COUNTY.

8) CONTRACTOR agrees to notify COUNTY of any claim by a third party or any incident or event that may give rise to a claim arising from the performance of this Agreement.

23. General

23.1 CONTRACTOR shall not delegate or assign any interest in this Agreement, whether by operation of law or otherwise, without the prior written consent of COUNTY. Any attempt to delegate or assign any interest herein shall be deemed void and of no force or effect.

23.2 Any waiver by COUNTY of any breach of any one or more of the terms of this Agreement shall not be construed to be a waiver of any subsequent or other breach of the same or of any other term of this Agreement. Failure on the part of COUNTY to require exact, full, and complete compliance with any terms of this Agreement shall not be construed as in any manner changing the terms or preventing COUNTY from enforcement of the terms of this Agreement.

23.3 In the event the CONTRACTOR receives payment under this Agreement, which is later disallowed by COUNTY for nonconformance with the terms of the Agreement, the CONTRACTOR shall promptly refund the disallowed amount to the COUNTY on request; or at its option the COUNTY may offset the amount disallowed from any payment due to the CONTRACTOR.

23.4 CONTRACTOR shall not provide partial delivery or shipment of services or products unless specifically stated in the Agreement.

23.5 CONTRACTOR shall not provide any services or products subject to any chattel mortgage or under a conditional sales contract or other agreement by which an interest is retained by a third party. The CONTRACTOR warrants that it has good title to all materials or products used by CONTRACTOR or provided to COUNTY pursuant to this Agreement, free from all liens, claims, or encumbrances.

23.6 Nothing in this Agreement shall prohibit the COUNTY from acquiring the same type or equivalent equipment, products, materials or services from other sources, when deemed by the COUNTY to be in its best interest. The COUNTY reserves the right to purchase more or less than the quantities specified in this Agreement.

23.7 The COUNTY agrees to cooperate with the CONTRACTOR in the CONTRACTOR's performance under this Agreement, including, if stated in the Agreement, providing the CONTRACTOR with reasonable facilities and timely access to COUNTY data, information, and personnel.

23.8 CONTRACTOR shall comply with all applicable Federal, State and local laws and regulations. CONTRACTOR will comply with all applicable COUNTY policies and procedures. In the event that there is a conflict between the various laws or regulations that may apply, the CONTRACTOR shall comply with the more restrictive law or regulation.

23.9 CONTRACTOR shall comply with all air pollution control, water pollution, safety and health ordinances, statutes, or regulations, which apply to performance under this Agreement.

23.10 CONTRACTOR shall comply with all requirements of the Occupational Safety and Health Administration (OSHA) standards and codes as set forth by the U.S. Department of Labor and the State of California (Cal/OSHA).

23.11 This Agreement shall be governed by the laws of the State of California. Any legal action related to the performance or interpretation of this Agreement shall be filed only in the Superior Court of the State of California located in Riverside, California, and the parties waive any provision of law providing for a change of venue to another location. In the event any provision in this Agreement is held by a court of competent jurisdiction to be invalid, void, or unenforceable, the remaining provisions will nevertheless continue in full force without being impaired or invalidated in any way.

23.12 This Agreement, including any attachments or exhibits, constitutes the entire Agreement of the parties with respect to its subject matter and supersedes all prior and contemporaneous representations, proposals, discussions and communications, whether oral or in writing. This Agreement may be changed or modified only by a written amendment signed by authorized representatives of both parties.

IN WITNESS WHEREOF, the parties hereto have caused their duly authorized representatives to execute this Agreement.

COUNTY:

County Administration Center
4080 Lemon St., 4th Floor
Riverside, CA 92501
Board of Supervisors

Signature: John J. Benoit

Print Name: John J. Benoit

Title: Chairman of the Board of Supervisors

Dated: APR 23 2013

CONTRACTOR:

Bio-Tox Laboratories
1965 Chicago Ave. #C
Riverside, CA 92507
Tracey Stangarone

Signature: Tracey Stangarone
for

Print Name: Tracey Stangarone

Title: Business Manager / President

Dated: 3/26/13

FORM APPROVED COUNTY COUNSEL

BY: Neal R. Kipnis DATE: 3/26/13

ATTEST:

KECIA HARRER-IHEM, Clerk

By: [Signature]
DEPUTY

**EXHIBIT A
SCOPE OF SERVICE**

Scope of Services

1.0 Response Time: Contractor will provide an acceptable response time from notification that a specimen is ready for pickup. Preliminary drug screening results should be available within 24 to 48 hours after pick up, followed by confirmation testing of presumptive positive screened results. "Stat" sample testing will be completed in 24 hours or less. Delivery/postmark if mailing of a final report, is to be no longer than (3) three working days (working days are 8:00 am to 5:00 pm, Monday through Friday). Final laboratory reports are to be delivered to the requesting agency. The laboratory shall be appropriately staffed to allow for STAT drug testing when requested by the agency.

2.0 Licenses & Certification:

- a. Qualifications of the lab director should include being licensed by the California Department of Health Services as a Supervising Clinical Toxicologist or a Board Certified Forensic Toxicologist;
- b. Supervisors of analyst must be licensed by the California Department of Health Services in Clinical Toxicology;
- c. It is recommended that the laboratory meet the Scientific and Technical Guidelines, and Standards for Certification of Laboratories engaged in urine drug testing for Federal agencies. The laboratory must be accredited in Forensic Toxicology by the American Board of Forensic Toxicology (ABFT).

3.0 Experience: Suppliers and agents of Contractor must be familiar with the handling of evidence and the proper protocol for documenting and maintaining the correct chain of evidence. All aspects of testing must be appropriately documented. The documentation will include personnel files on analysts, supervisors, directors and all persons with access to specimens; chain of custody documents; quality assurance/control records; all test data; performance on proficiency testing can be accomplished and there is no deterioration of these items of evidence.

4.0 Expert Witness: The County of Riverside reserves the right to request replacement of any professional during the life of this agreement that is found to be unacceptable to the Court. Contractor shall provide analysts and expert witnesses that have previously been established in court proceedings by judges and attorneys. Coroner Review consultations shall be provided by toxicologists familiar with post mortem cases and work in conjunction with coroner staff when additional investigative measures are warranted.

5.0 Testing Procedures:

- a. Testing must consist of the screening of appropriate bodily liquids (e.g., blood, urine, bile, vitreous, gastric contents) and tissues (e.g., liver, brain, spleen, muscle) for the presence or absence of drugs, followed by confirmation of the amounts of drugs by a second procedure based on a different chemical principle.
- b. Initial screening can be done by Enzyme Multiplied Immunoassay Test (EMIT) or Radioactive Immunoassay Test (RIA); however, only gas chromatography/mass spectroscopy will be considered acceptable for conformation testing (thin layer

- chromatography is unacceptable). Examples of drug panels, which may be required for testing, are noted in Exhibit B - Payment Provisions.
- c. Procedures for testing samples will include screening techniques such as Immunoassay Elisa kits, used in conjunction with Tecan instrumentation. The assays are used to determine the presence of a parent molecule and/or metabolite of drugs of abuse in forensic samples such as whole blood, serum, plasma, urine, and/or tissues.
 - d. Contractor may also use Liquid Chromatography/Mass Spectrometry/Mass Spectrometry (LC/MS/MS) analytical equipment for detecting the presence of drugs. Confirmation analysis will consist of LC/MS/MS. The second MS denotes tandem Mass Spectrometry, an additional separation step. LC/MS/MS will be used to provide quantitative results in most cases. In an effort to provide optimum result accuracy and efficiency, Contractor may enhance analytical methods to include new equipment and procedures.
 - e. Contractor may utilize one or more secondary toxicology laboratories for forensic testing of substances not provided by the primary laboratory (Send out or other reference laboratory).
 - f. The secondary facility shall conform to the license and certification requirements of the primary laboratory. Analysis not performed by Contractor may be sent to a secondary toxicology laboratory whereby Contractor acts as a pass-through laboratory for convenience to the Sheriff Department.
 - g. Contractor has existing accounts with reference laboratories and will handle the sample packaging and shipping once in house testing has been completed. Contractor will accept the routine billing and payment responsibilities for these tests and pass through the results from the specified laboratory. Fees for these services will be billed accordingly during monthly invoice cycles.
 - h. Chain of custody will be maintained by Contractor until the point of shipping, at which time the chain of custody is transferred to the reference lab. Reference lab will maintain chain of custody and provide the sample return upon request.

6.0 Locations: Locations where the lab may expect to obtain specimens from however, this is not to be considered a complete list. It is only a representation of the major places that were used in the past.

- o *Riverside County Sheriff-Coroner Forensic Center West, Perris, CA*
- o *Riverside County Sheriff-Coroner Forensic Center East, Indio, CA*
- o *Riverside County Sheriff-Jail, Riverside, CA*
- o *Riverside County Sheriff-Jail, Indio, CA*
- o *Riverside County Sheriff-Jail, Southwest Justice Center, CA*
- o *Riverside County Sheriff Station's- Jurupa Valley, Moreno Valley, Southwest, Lake Elsinore, Perris, Cabazon, Palm Desert & Indio.*

City of Corona Police Department
 Corona Police Dept.
 849 W. Sixth Street
 Corona, CA 92882
 (951) 279-3685

Riverside Police Department
 10540 Magnolia Avenue
 Riverside, CA 92505
 (951) 353-7100

City of Riverside Police Department
 Riverside Police Department
 4102 Orange Street
 Riverside, CA 92501
 (951) 787-7911

Riverside Community Hospital
 4445 Magnolia Avenue
 Riverside, CA 92501
 (951) 788-3200

County Regional Medical Center
26520 Cactus Avenue
Moreno Valley, CA 92555
(951) 486-5650

Parkview Community Hospital
3865 Jackson Street
Riverside, CA 92503
(951) 688-2211

Kaiser Riverside-Park Sierra
10800 Magnolia Ave.
Riverside, CA 92505
(951) 353-3790

7.0 Special Considerations: The Contractor shall include an itemized listing of any potential special fees (e.g., handling charges, chain of custody, tissue preparation) and listing of tests requiring a secondary laboratory (send outs). It shall specify approximate turnaround times for reporting of results on routine, rush and STAT cases. Specimens are to be maintained for duration to be specified by the agency (at least three (3) years). At the present time, the Riverside County Sheriff-Coroner performs approximately 1100-1500 autopsies per year and 1000 consultations (examination of the decedent without autopsy). The investigation of most of the autopsied decedents requires varying degrees of toxicological support on one or more specimens. A number of decedents not requiring autopsy will be expected to have a toxicological workup.

**EXHIBIT B
PAYMENT PROVISIONS**

TEST DESCRIPTION	FEE
ALCOHOL	
ALCOHOL, URINE	39.00
ALCOHOL, VITREOUS	39.00
ALCOHOL, BLOOD	39.00
ALCOHOL, TISSUE	49.00
ALCOHOLIC BEVERAGE (including Pruno)	95.00
VOLITALES PANEL (ACETONE, ISOPROPANOL, METHANOL)	78.00
ANTICONVULSANT PANEL	
ANTICONVULSANT PANEL, SCREEN	125.00
ETHOSUXIMIDE	
10-HYDROXYCARBAZEPINE	
BUTABARBITAL	
BUTALBITAL	
CARBAMAZEPINE	
CARBAMAZEPINE, 10, 11-EPOXIDE	
DIAZEPAM	
GABAPENTIN	
GLUTETHIMIDE	
LAMOTRIGINE	
LEVETIRACETAM	
MEPHENYTOIN	
MEPHOBARBITAL	
METHSUXIMIDE	
NORDIAZEPAM	
NORMETHSUXIMIDE	
OXCARBAZEPINE	
PENTOBARBITAL	
PHENYTOIN	
PRIMIDONE	
SECOBARBITAL	
TOPIRAMATE	
BARBITURATE CONFIRMATION, LC/MS/MS	
BARBITURATE CONFIRMATION, LC/MS/MS	125.00
BUTALBITAL	
PHENOBARBITAL	
PENTOBARBITAL	
SECOBARBITAL	
BENZODIAZEPINES CONFIRMATION, LC/MS/MS	
BENZODIAZEPINES CONFIRMATION, LC/MS/MS	145.00
ALPRAZOLAM	
CHLORDIAZEPOXIDE	
CLONAZEPAM	
DIAZEPAM	
ESTAZOLAM	

FLUNITRAZEPAM	
FLURAZEPAM	
LORAZEPAM	
MIDAZOLAM	
OXAZEPAM	
TEMAZEPAM (RESTORIL)	
TRIAZOLAM (HALCION)	
HYDROXALPRAZOLAM	
7-AMINOCLONAZEPAM	
NORCHLORDIAZEPOXIDE	
NORDIAZEPAM	
DESALKYLFLURAZEPAM	
AMINOFLUNITRAZEPAM	
HYDROXYTRIAZOLAM	
CANNABINOIDS CONFIRMATION, LC/MS/MS	
CANNABINOIDS CONFIRMATION, LC/MS/MS (BLOOD OR URINE)	85.00
COCAINE CONFIRMATION, LC/MS/MS	
COCAINE CONFIRMATION, LC/MS/MS	69.00
BENZOYLECGONINE	
COCAETHYLENE	
COMPREHENSIVE PANEL DRUG SCREEN	
COMPREHENSIVE PANEL DRUG SCREEN (BLOOD, URINE OR VITREOUS)-OVER 150 PRESCRIPTION DRUGS	114.94
COMPREHENSIVE PANEL DRUG SCREEN (TISSUE)	124.94
CORONER PANEL DRUG SCREEN	
CORONER PANEL DRUG SCREEN (URINE, BLOOD OR VITREOUS)-AMPHETAMINES, BARBITURATES, BENZODIAZEPINES, CANNABINOIDS, COCAINE METABOLITE, OPIATES, PCP, ALCOHOL	55.00
CORONER PANEL DRUG SCREEN (TISSUE)	65.00
OTHER DRUG SCREENS	
4 PANEL DRUG SCREEN (COCAINE METABOLITE, METHAMPHETAMINE, OPIATES, PCP)-ANTI MORTEM CASES ONLY	25.00
AMPHETAMINES SCREEN (URINE, BLOOD OR VITREOUS)	19.00
AMPHETAMINES SCREEN, TISSUE	25.00
BARBITURATES SCREEN	35.00
BATH SALTS DRUG SCREEN	125.00
BENZODIAZEPINES SCREEN	19.00
CANNABINOIDS SCREEN	19.00
COCAINE METABOLITE SCREEN	19.00
DESIGNER STIMULANT SCREEN	125.00
EXPANDED IA SCREEN (BENZODIAZEPINES, CANNABINOIDS + 4 PANEL)-ANTI MORTEM CASES ONLY	35.00
LSD SCREEN	75.00
METHADONE SCREEN, LC/MS/MS	45.00
OPIATES SCREEN, TISSUE	25.00
OPIATES SCREEN (URINE, BLOOD OR VITREOUS)	19.00
PHENCYCLIDINE SCREEN	19.00
METHAMPHETAMINE CONFIRMATION, LC/MS/MS	
METHAMPHETAMINE CONFIRMATION, LC/MS/MS	69.00
AMPHETAMINE	
METHYLENEDIOXYAMPHETAMINE (MDA)	
METHYLENEDIOXYMETHAMPHETAMINE (MDMA)	
BETA-PHENETHYLAMINE	

OPIATE CONFIRMATION, LC/MS/MS	
OPIATE CONFIRMATION, LC/MS/MS	85.00
MORPHINE	
CODEINE	
OXYCODONE	
HYDROCODONE	
HYDROMORPHONE	
OXYMORPHONE	
MONOACETYLMORPHINE	
PHENCYCLIDINE CONFIRMATION, LC/MS/MS	
PHENCYCLIDINE, LC/MS/MS	35.00
PRESCRIPTION DRUGS (WITH METABOLITE) AND OTHER	
ACETAMINOPHEN	75.00
ALBUTEROL	99.00
AMITRIPTYLINE	99.00
ATENOLOL	99.00
BACLOFEN	125.00
BENZTROPINE	75.00
BROMPHENIRAMINE	99.00
BUPRENORPHINE	99.00
BUPROPION	125.00
BUSPIRONE (BUSPAR)	99.00
CARBAMAZEPINE	99.00
CARISOPRODOL	99.00
CHLORPHENIRAMINE	99.00
CHLORPROMAZINE	99.00
CITALOPRAM	99.00
CLOMIPRAMINE	99.00
CLONIDINE	99.00
CYCLOBENZAPRINE	99.00
DESIGNER STIMULANT CONFIRMATION, PER DRUG	105.00
DEXTROMETHORPHAN	99.00
DIPHENHYDRAMINE	79.00
DOXEPIN	79.00
DOXYLAMINE	99.00
DULOXETINE	99.00
FENTANYL	99.00
FLUOXETINE	99.00
GABAPENTIN	125.00
GAMMA-HYDROXYBUTYRIC	195.00
HALOPERIDOL	99.00
HYDROXYZINE	99.00
KETAMINE	99.00
LAMOTRIGINE	99.00
LEVETIRACETAM	99.00
LEVORPHANOL	99.00
LIDOCAINE	99.00
MECLIZINE	89.00
MEPERIDINE	99.00
MESCALINE	75.00

METHADONE	75.00
METHOCARBAMOL	99.00
METHYLPHENIDATE	99.00
MIRTAZAPINE	99.00
NALOXONE	99.00
OLANZAPINE	99.00
OXCARBAZEPINE	99.00
PAROXETINE	99.00
PHENAZEPAM	99.00
PHENTERMINE	99.00
PHENYLPROPANOLAMINE	99.00
PHENYTOIN	125.00
PRIMIDONE	99.00
PROMETHAZINE	125.00
PROPRANOLOL	99.00
PSEUDOEPHEDRINE	99.00
QUETIAPINE	99.00
RISPERIDONE	99.00
SCOPOLAMINE	99.00
SERTRALINE	99.00
TOPIRAMATE	99.00
TRAMADOL	99.00
TRAZODONE	99.00
VENLAFAXINE	99.00
VERAPAMIL	99.00
ZALEPLON	99.00
ZIPRASIDONE	99.00
ZOLPICLONE	99.00
ZOLPIDEM	99.00
SPECIAL FEES	
CAPITATION CORONER PANEL*	375.00
CAPITATION COMPREHENSIVE PANEL*	600.00
CAPITATION CORONER REVIEW*	800.00
CHAIN OF CUSTODY-storage only per sample; no testing; anti mortem	12.00
CHAIN OF CUSTODY-storage only per sample; no testing post mortem after first 3 samples	12.00
HANDLING, SHIPPING & SPECIAL CARE	AT COST
LEAKING SAMPLE	15.00
MATRIX EFFECT-Unsuccessful analysis due to unusual problems with submitted sample.	150.00
NAME DISCREPANCY	15.00
RUSH SAMPLE ANALYSIS-1-2 weeks turnaround time depending on complexity of case	no charge
STAT PICK UP FEE-60 MILE MAXIMUM (Call for other arrangements outside of 60 miles)	75.00
SAMPLE RETURN	15.00
STAT FEE, PER TEST-24 to 48 hours turnaround time	200.00
TISSUE PREPARATION	50.00

*Capitation fees only include drugs tested at Contractor and are inclusive of the coroner panel or comprehensive panel drugs. (i.e. Bath salts not included and GHB are not included in cap rates.

Note: Drugs listed are subject to review and change as deemed necessary by laboratory management.

This page intentionally left blank.

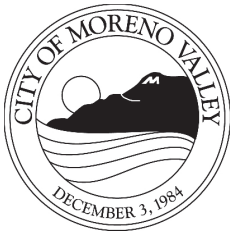

APPROVALS	
BUDGET OFFICER	<i>me</i>
CITY ATTORNEY	<i>SMB</i>
CITY MANAGER	<i>d</i>

Report to City Council

TO: Mayor and City Council

FROM: Ahmad R. Ansari, P.E., Public Works Director/City Engineer

AGENDA DATE: August 27, 2013

TITLE: PA07-0080 (PM 35672) – APPROVE PARCEL MAP AND ACCEPT THE AGREEMENT AND SECURITY FOR PUBLIC IMPROVEMENTS

RECOMMENDED ACTION

Recommendations:

1. Approve Parcel Map 35672 and authorize the City Clerk to sign the map and transmit said map to the County Recorder's Office for recordation.
2. Accept the Agreement and Security for Public Improvements.
3. Authorize the Mayor to execute the Agreement.
4. Direct the City Clerk to forward the signed Agreement to the County Recorder's Office for recordation.
5. Authorize the City Engineer to execute any future time extension amendments to the agreement, subject to City Attorney approval, if the required public improvements are not completed within said timeframe.

BACKGROUND

On July 8, 2008 the City Council of the City of Moreno Valley approved Tentative Parcel Map No. 35672 (PA07-0080) and a Plot Plan (PA08-0018) for a one-building option 1,560,046 square foot industrial building. The parcel map proposes to consolidate 80.24 gross acres into one (1) parcel. The map is located at the southeast corner of Iris Avenue and Indian Street.

On May 16, 2013 the developer submitted a planning application for Amended Plot Plan PA13-0022, an amendment to original Plot Plan PA08-0018. The Amended Plot Plan PA13-0022 proposes a 1,476,017 square foot building. Staff has reviewed the Amended Plot Plan and is in the process of recommending approval of the project to the Community and Economic Development Director.

The required improvements in the conditions of approval associated with the tentative map approval will not change as a result of the approval of Amended Plot Plan PA13-0022. On February 11, 2009, a Cooperative Agreement, among the developer, the City, and Riverside County Flood Control and Water Conservation District recorded, obligating the developer to construct master storm drain facilities within Indian Street and Krameria Avenue consistent with the Sunnymead Area Drainage Plan.

DISCUSSION

Parcel Map No. 35672 is in substantial conformance with the approved tentative map. The developer has requested that the map be approved for recordation. The Conditions of Approval for this project require that the developer provide surety for the required improvements. Public improvements are to be constructed on Iris Avenue, Indian Street, Krameria Avenue, and Cosmos Street.

The developer of this project has completed an Agreement for Public Improvements. The developer agrees to perform and complete all of the required street improvements within twenty-four (24) months of the date the agreement is executed. The street improvements include, but are not limited to: asphalt, base, curb, gutter, sidewalk, street lights, storm drain, catch basins, striping, signage, water, sewer, and undergrounding overhead utilities. The City Engineer may execute any future amendments to the agreement, subject to City Attorney approval, if the required street improvements are not completed within said timeframe.

Accompanying the agreement is Faithful Performance bond in the amount of \$8,664,000 and a Material and Labor bond in the amount of \$4,332,000 issued by XL Specialty Insurance Company.

FISCAL IMPACT

No fiscal impact is anticipated.

CITY COUNCIL GOALS

PUBLIC FACILITIES AND CAPITAL PROJECTS:

Ensure that needed public facilities, roadway improvements, and other infrastructure improvements are constructed and maintained.

NOTIFICATION

Publication of agenda.

ATTACHMENTS

- Attachment 1 – Vicinity Map
- Attachment 2 – Agreement for Public Improvements
- Attachment 3 – Faithful Performance Bond
- Attachment 4 – Material and Labor Bond

Prepared By:
Liz Plazola
Sr. Administrative Assistant

Department Head Approval:
Ahmad R. Ansari, P.E.
Public Works Director/City Engineer

Concurred By:
Mark W. Sambito, P.E.
Engineering Division Manager

Council Action	
Approved as requested:	Referred to:
Approved as amended:	For:
Denied:	Continued until:
Other:	Hearing set for:

This page intentionally left blank.

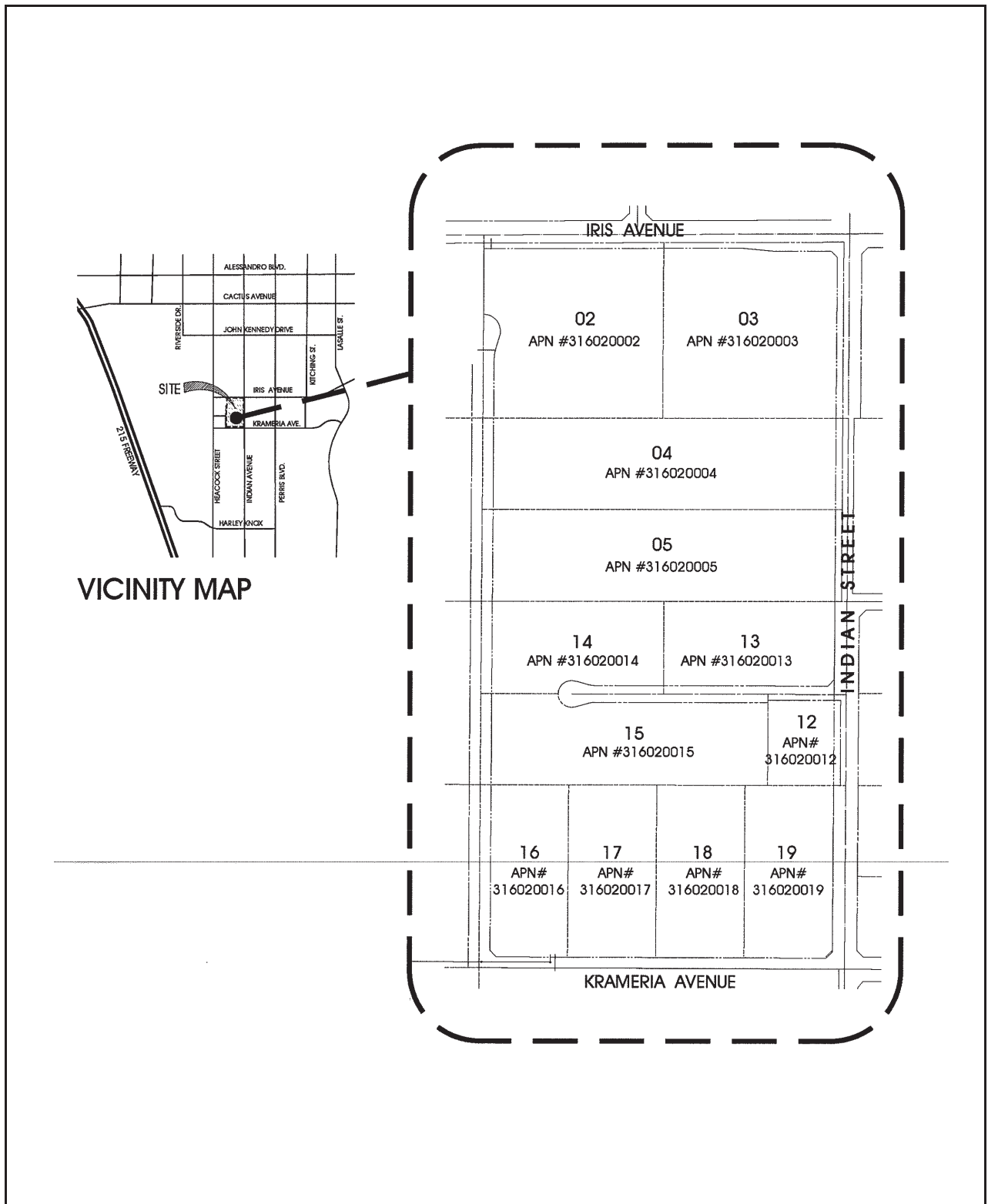

CITY OF MORENO VALLEY
PUBLIC WORKS DEPARTMENT - LAND DEVELOPMENT

PA07-0080

This page intentionally left blank.

**AGREEMENT FOR PUBLIC IMPROVEMENTS
FOR
PROJECT NO. PA07-0080 (PARCEL MAP 35672)**

This Agreement, made and entered into by and between the City of Moreno Valley, State of California, hereinafter called City, and **Panattoni Construction, Inc.**, herein after called Developer, on the date the City signs this agreement.

WITNESSETH:

FIRST: Developer, for and in consideration of the approval by the City of the final map of that certain land division, or that certain other land development project, known as **PA07-0080 (PM 35672)** agrees, at Developer's own expense, to furnish all labor, equipment and material necessary, and within **TWENTY-FOUR (24)** months from the date this Agreement is executed, to perform and complete in a good and workmanlike manner, all of the required improvements in accordance with those improvement plans for said project which have been approved by the City Engineer, and are on file in the office of the City Engineer, and to do all work incidental thereto in accordance with the standards set forth in City ordinances and regulations, and pay all costs of engineering necessary in connection therewith, which are expressly made a part of this Agreement. All of the above required work shall be done under the inspection of and to the satisfaction of the City Engineer, and shall not be deemed complete until approved and accepted as complete by the City. Developer further agrees to guarantee the required improvements for a period of one year following acceptance by the City and during this one year period to repair and replace, to the satisfaction of the City Engineer, any defective work or labor done or defective materials furnished. Developer shall complete the improvements described in this paragraph pursuant to Section 66462, Government Code. Developer shall also complete any offsite improvements required as a condition of approval and with plans approved by the City Engineer at such time as the City acquires an interest in the land which will permit the improvements to be made, and the Developer waives the 120 day time limitation set forth in Section 66462.5, Government Code.

Security to guarantee the performance of this agreement shall be in the following amounts:

Faithful Performance security shall be in the sum of **EIGHT MILLION SIX HUNDRED SIXTY FOUR THOUSAND AND NO/100** Dollars (*****\$8,664,000.00*****). The estimated cost of said work and improvements, pursuant to the Preliminary Estimate of Cost labeled Exhibit A attached hereto.

Labor and Material security shall be in the sum of **FOUR MILLION THREE HUNDRED THIRTY TWO THOUSAND AND NO/100** Dollars (*****\$4,332,000.00*****). The estimated cost securing payment of labor and materials is fifty (50) percent of the total cost estimate of the improvements.

Developer further agrees to guarantee the required improvements for a period of one year following acceptance by the City and during this one year period to repair and replace, to the satisfaction of the City Engineer, any defective work or labor done or defective materials furnished. Upon entering the warranty period, the City shall retain ten percent of the original faithful performance security. Developer reserves the right to substitute the form of security, in accordance with the Moreno Valley Municipal Code, at any time during the term of this agreement, subject to approval of the City Engineer and City Attorney.

SECOND: Developer agrees to file with City, prior to the date this Agreement is executed, a good and sufficient improvement security in an amount not less than the estimated cost of the work and improvements for the faithful performance of the terms and conditions of this Agreement, and good and sufficient security for payment of labor and materials in the amount prescribed by City ordinances and regulations to secure the claims to which reference is made in Title 15 (commencing with Section 3082) of Part 4 of Division 3 of the Civil Code of the State of California. Developer agrees to renew each and every said bond or bonds with good and sufficient sureties or increase the amounts of said bond or bonds, or both, within ten (10) days after being notified by the City Engineer that the sureties or amounts are insufficient. Notwithstanding any other provision herein, if Developer fails to take such action as is necessary to comply with said notice, he shall be in default of this Agreement unless all required improvements are completed within ninety (90) days of the date on which

the City Engineer notified the Developer of the insufficiency of said bonds. Developer reserves the right to substitute the form of security in accordance with the City's Municipal Code at anytime during the term of this agreement, subject to approval by the City Engineer and City Attorney.

THIRD: Developer agrees to pay to the City the actual cost of such inspection of the works and improvements as may be required by the City Engineer. Developer further agrees that, if suit is brought upon this Agreement or any bond guaranteeing the completion of the required improvements, all costs and reasonable expenses and fees incurred by the City in successfully enforcing such obligations shall be paid by Developer and guaranteed by the surety in addition to the face amount of the security, including reasonable attorney's fees, and that, upon entry of judgment, such costs, expenses and fees shall be taxed as costs and included in any judgment rendered.

FOURTH: City shall not, nor shall any officer or employee of City, except for its or their sole negligence, be liable or responsible for any accident, loss or damage happening or occurring to the works specified in this Agreement prior to the completion and approval thereof, nor shall City or any officer or employee thereof, be liable for any persons or property injured by reason of the nature of the work, or by reason of the acts or omissions of Developer, his agents or employees, in the performance of the work, and all of said liabilities are assumed by Developer. Developer agrees to protect, defend and hold harmless City and the officers and employees thereof from all loss, liability or claim because of, or arising out of the acts or omissions of Developer, his agents and employees, in the performance of this Agreement, or arising out of the use of any patent or patented article in the performance of this Agreement.

FIFTH: The Developer hereby grants to the City and/or to any authorized agent or employee of the City, the irrevocable permission to enter upon the lands of the above-referenced land division for the purpose of completing the improvements. This permission shall terminate in the event that the Developer has completed the work within the time specified or any extension thereof granted by the City.

SIXTH: Developer agrees at all times, up to the completion and acceptance of the improvements by the City, to give good and adequate warning to the traveling public of each and every dangerous condition caused by the construction of the improvements, and to protect the traveling public from such defective or dangerous conditions. The Developer shall keep all traveled ways that are a part of, or affected by the construction of this project free and clear of mud, dirt and debris and shall provide twice monthly street sweeping service. A copy of the contract for street sweeping service shall be provided to the City. The Developer's obligation under this provision shall be secured by the bonds securing performance of this Agreement.

SEVENTH: The Developer, his agents and employees, shall give notice to the City Engineer at least 48 hours before beginning any work and shall furnish said City Engineer all reasonable facilities for obtaining full information with respect to the progress and manner of work.

EIGHTH: If the Developer, or his agents or employees, neglects, refuses, or fails to prosecute the work with such diligence as to insure its completion within the specified time, or within such extensions of time as have been granted by the City, or if the Developer violates, neglects, refuses, or fails to perform satisfactorily any of the provisions of the plans and specifications, he shall be in default of this Agreement and notice in writing of such default shall be served upon him. The City Council shall have the power, on recommendation by the City Engineer, to terminate all rights of the Developer because of such default. The determination by the City Engineer of the question as to whether any of the terms of the Agreement or specifications have been violated, or have not been performed satisfactorily, shall be conclusive upon the Developer, and any and all parties who may have any interest in the Agreement or any portion thereof. The foregoing provisions of this section shall be in addition to all other rights and remedies available to the City under law.

NINTH: It is further agreed by and between the parties hereto, including the surety or sureties on the bonds securing this Agreement that, in the event it is deemed necessary to extend the time of completion of the work contemplated to be done under this Agreement, extensions of time **may** be granted by the City from time to time, either at its own option, or upon request of Developer, and such extensions shall in no way affect the validity of this Agreement or release the surety or sureties on said bonds, Developer further agrees to maintain the aforesaid bonds in full force and effect during the terms of this Agreement, including any extensions of time as may be granted therein.

TENTH: It is understood and agreed by the parties hereto that if any part, term or provision of this Agreement is by the courts held to be unlawful and void, the validity of the remaining portions shall not be affected and the rights and obligations of the parties shall be construed and enforced as if the Agreement did not contain the particular part, term or provision held to be invalid.

ELEVENTH: Any notice or notices required or permitted to be given pursuant to this Agreement shall be served on the other party by mail, postage prepaid, at the following addresses:

City:
City Engineer
P.O. Box 88005
14177 Frederick
Moreno Valley, CA 92552-0805

Developer:
Panattoni Construction, Inc.
8775 Folsom Blvd.
Suite 201
Sacramento, CA 95826

IN WITNESS WHEREOF Developer has affixed his name, address and seal.

Date approved by the City: _____

Panattoni Construction, Inc.:
Developer

BY: SEE ATTACHED SIGNATURE PAGE
Signature

BY: SEE ATTACHED SIGNATURE PAGE
Signature

Print/Type Name

Print/Type Name

Title

Title

**ATTEST:
CITY CLERK
OF THE CITY OF MORENO VALLEY**

CITY OF MORENO VALLEY

By: _____
City Clerk

By: _____
Mayor

(SEAL)

**APPROVED AS TO FORM:
CITY ATTORNEY**

Date: _____

By: _____
City Attorney

NOTE: TWO SIGNATURES ARE REQUIRED FOR CORPORATIONS UNLESS CORPORATE DOCUMENTS ARE PROVIDED THAT INDICATES OTHERWISE.

SIGNATURES OF DEVELOPER MUST BE EXECUTED IN QUADRUPPLICATE AND THE EXECUTION OF THE ORIGINAL COPY MUST BE ACKNOWLEDGED BEFORE A NOTARY
ORIGINAL - CITY CLERK; PINK - DEVELOPER; GREEN - SURETY; BLUE - PROJECT FILE

SIGNATURE PAGE
AGREEMENT FOR PUBLIC IMPROVEMENTS
PROJECT NO. PA07-0080 (PARCEL MAP 35672)
JUNE 27, 2013

PANATTONI CONSTRUCTION, INC.
a California corporation

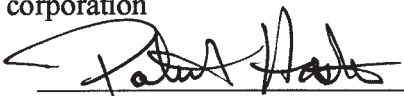
By: 
Name: PATRICK HASTIE
Its: SE VP.

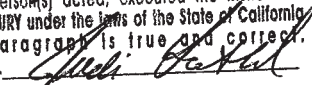
State of California, County of Orange
On July 3, 2013 before me, Judi Lowenthal, Notary Public,
Personally appeared PATRICK HASTIE
who proved to me on the basis of satisfactory evidence to be the person
whose name is subscribed to the within instrument and acknowledged
to me that he/she/they executed the same in his/her/their authorized capacity,
and that by his/her/their signature on the instrument the person(s), or the entity
upon behalf of which the person(s) acted, executed the instrument.
I certify under PENALTY OF PERJURY under the laws of the State of California
that the foregoing paragraph is true and correct.
WITNESS my hand and official seal. 



SIGNATURE PAGE
AGREEMENT FOR PUBLIC IMPROVEMENTS
PROJECT NO. PA07-0080 (PARCEL MAP 35672)
JUNE 27, 2013

PANATTONI CONSTRUCTION, INC.
a California corporation

By: 
Name: EVAN HAMILTON
Its: SVP

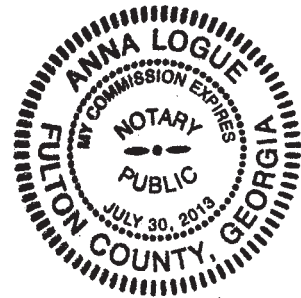



EXHIBIT "A"
ENGINEER'S ESTIMATE

Sheet 1 of 8

PROJECT: PM35672

DATE: 06/13/13
PREPARED BY: SH / BB

sg

OFFSITE PAVEMENT SECTIONS

TYPE	QUANTITY	UNIT	UNIT PRICE	TOTAL	
Street Work - Non DIF Non TUMF					
A.B. Class II - Krameria South	0.75	Thickness (ft.)	0 C.Y.	20.00	0
	57550	S.F.	3129 Ton	55.00	172,110
A.C. - Krameria South	0.45	Thickness (ft.)	1878 Ton	90.00	168,981
	57550	S.F.	0 C.Y.	20.00	0
A.B. Class II - Krameria North	0.75	Thickness (ft.)	2463 Ton	55.00	135,475
	45300	S.F.	1478 Ton	90.00	133,012
A.C. - Krameria North	0.45	Thickness (ft.)	0 C.Y.	20.00	0
	45300	S.F.			
A.B. Class II - Cosmos	1	Thickness (ft.)	7813 Ton	55.00	429,733
	107770	S.F.	3907 Ton	90.00	351,600
A.C. - Cosmos	0.5	Thickness (ft.)	0 C.Y.	20.00	0
	107770	S.F.			
A.B. Class II - Street 4	0	Thickness (ft.)	0 Ton	55.00	0
	0	S.F.			
A.C. - Street 4	0	Thickness (ft.)	0 Ton	90.00	0
	0	S.F.			
Street Work - DIF					
A.B. Class II - Iris	1	Thickness (ft.)	0 C.Y.	20.00	0
	92185	S.F.	6683 Ton	55.00	367,588
A.C. - Iris	0.5	Thickness (ft.)	3342 Ton	90.00	300,754
	92185	S.F.	0 C.Y.	20.00	0
A.B. Class II - Indian	0.75	Thickness (ft.)	9309 Ton	55.00	511,995
	171200	S.F.	5585 Ton	90.00	502,686
A.C. - Indian	0.45	Thickness (ft.)	0 C.Y.	20.00	0
	171200	S.F.			
A.B. Class II - Street 3	0	Thickness (ft.)	0 Ton	55.00	0
	0	S.F.			
A.C. - Street 3	0	Thickness (ft.)	0 Ton	90.00	0
	0	S.F.	0 C.Y.	20.00	0
A.B. Class II - Street 4	0	Thickness (ft.)	0 Ton	55.00	0
	0	S.F.			
A.C. - Street 4	0	Thickness (ft.)	0 Ton	90.00	0
	0	S.F.			
Street Work - TUMF					
A.B. Class II - Street 1	0	Thickness (ft.)	0 C.Y.	20.00	0
	0	S.F.	0 Ton	55.00	0
A.C. - Street 1	0	Thickness (ft.)	0 Ton	90.00	0
	0	S.F.	0 C.Y.	20.00	0
A.B. Class II - Street 2	0	Thickness (ft.)	0 Ton	55.00	0
	0	S.F.			
A.C. - Street 2	0	Thickness (ft.)	0 Ton	90.00	0
	0	S.F.	0 C.Y.	20.00	0
A.B. Class II - Street 3	0	Thickness (ft.)	0 Ton	55.00	0
	0	S.F.			
A.C. - Street 3	0	Thickness (ft.)	0 Ton	90.00	0
	0	S.F.	0 C.Y.	20.00	0
A.B. Class II - Street 4	0	Thickness (ft.)	0 Ton	55.00	0
	0	S.F.			
A.C. - Street 4	0	Thickness (ft.)	0 Ton	90.00	0
	0	S.F.			
SUBTOTAL:				3,073,934	



EXHIBIT "A"
ENGINEER'S ESTIMATE

Sheet 2 of 8

PROJECT: PM35672

DATE: 06/13/13
PREPARED BY: Clement Jimenez



OFFSITE STREET WORK

TYPE	QUANTITY	UNIT	UNIT PRICE	TOTAL
Offsite Street Work				
Pavement				
Grind & Pave 0.15' (Iris)	5665	S.F.	3.25	18,411
Grind & Pave 0.15' (Krameria South)	5834	S.F.	3.25	18,961
A.C. Cap (Iris)	25	Ton	90.00	2,250
A.C. Overlay (Iris)	42	Ton	90.00	3,780
A.C. Overlay (Krameria South)	35	Ton	90.00	3,150
Slurry Seal (Based on \$150/Ton Type II)	0	S.Y.	2.25	0
Sawcut (Iris)	1830	L.F.	1.50	2,745
Sawcut (Indian)	172	L.F.	1.50	258
Sawcut (Krameria South)	0	L.F.	1.50	0
Utility Trench	0	L.F.	17.00	0
Trench Repaving	0	S.F.	12.00	0
Redwood Header (Krameria South)	0	L.F.	6.00	0
A.C. Berm - 6"	0	L.F.	10.00	0
A.C. Berm - 8" (Iris)	362	L.F.	15.00	5,430
A.C. Berm - 8" (Indian)	295	L.F.	15.00	4,425
Adjust M.H. to Grade (Iris)	2	EA.	800.00	1,600
Adjust Water Valve to Grade (Iris)	4	EA.	400.00	1,600
Adjust Water Valve to Grade (Indian)	2	EA.	400.00	800
Remove & Dispose Existing Pavement & Base (Iris)	42532	SF	3.00	127,596
Remove & Dispose Existing Pavement & Base (Indian)	102535	SF	3.00	307,605
Concrete				
P.C.C. Paving - 6"	0	S.F.	14.00	0
P.C.C. Paving - 8"	0	S.F.	16.00	0
Curb and Gutter - 6"	0	L.F.		0
Curb and Gutter - 8" (Krameria South)	1200	L.F.	25.00	30,000
Curb and Gutter - 8" (Cosmos)	2650	L.F.	25.00	66,250
Curb and Gutter - 8" (DIF - Iris)	1319	L.F.	25.00	32,975
Curb and Gutter - 8" (DIF - Indian)	2900	L.F.	25.00	72,500
Curb Only - 6"	0	L.F.	18.00	0
Curb Only - 8" (Iris Median)	1330	L.F.	20.00	26,600
Cross Gutter and Spandrel	0	S.F.	15.00	0
Sidewalk (Cosmos)	14000	S.F.	7.00	98,000
Sidewalk (Krameria South)	8742	S.F.	7.00	61,194
Sidewalk (Iris)	8570	S.F.	7.00	59,990
Sidewalk (Indian)	16603	S.F.	7.00	116,221
Driveway Approach - 6"	0	S.F.	14.00	0
Driveway Approach - 8" (Iris)	3500	S.F.	16.00	56,000
Driveway Approach - 8" (Indian)	800	S.F.	16.00	12,800
Driveway Approach - 8" (Krameria South)	0	S.F.	16.00	0
Driveway Approach - 8" (Cosmos)	4000	S.F.	16.00	64,000
Wheelchair Ramp (Indian)	2	EA.	1,200.00	2,400
Wheelchair Ramp (Krameria South)	1	EA.	1,200.00	1,200
Alley Approach - 8"	0	S.F.	16.00	0
1/2 Alley Apron	0	S.F.	16.00	0
Barricade	0	L.F.	100.00	0
Other				
SCE Underground Exist Power/Pole Removal	2650	L.F.	325.00	861,250
SCE/Telephone Conduit & Structure Allowance	2650	L.F.	245.00	649,250
Relocate Telephone Riser	1	EA.	10,000.00	10,000
Relocate Telephone Vault	2	EA.	20,000.00	40,000
Relocate SCE Vault	2	EA.	25,000.00	50,000
Underground Phone Cabling	2650	L.F.	25.00	66,250
			SUBTOTAL:	2,875,491

EXHIBIT "A"
ENGINEER'S ESTIMATE

Sheet 3 of 8

PROJECT: PM35672

DATE: 06/13/13

PREPARED BY: Clement Jimenez



OFFSITE STREET WORK (CONTINUED)

TYPE	QUANTITY	UNIT	UNIT PRICE	TOTAL
Special Districts				
Landscaping - Medians	0	S.F.	6.00	0
Landscaping - Parkways	0	S.F.	6.00	0
Street Lights (9500 lumen) (Cosmos)	8	EA.	4,000.00	32,000
Street Lights (22000 lumen) (Iris)	6	EA.	5,000.00	30,000
Street Lights (22000 lumen) (Indian)	12	EA.	5,000.00	60,000
Street Lights (22000 lumen) (Krameria South)	6	EA.	5,000.00	30,000
	SPECIAL DISTRICTS SUBTOTAL:			152,000.00
Moreno Valley Utilities				
Electrical Utility Infrastructure	0	L.S.	0.00	0
Electrical Utility Line Extension	0	L.F.	135.00	0
	MVU SUBTOTAL:			0
Water Quality Basin				
Landscaping	0	S.F.	6.00	0.00
Filtration Devices	0	EA.	0	0
Access Ramp PCC	0	S.F.	0	0
Low-Flow Pipe System	0	L.F.	0	0
Headwalls	0	EA.	0	0
Outlets	0	EA.	0	0
Risers	0	EA.	0	0
Forebay PCC	0	S.F.	0	0
Toe of slope protection PCC	0	S.F.	20.00	0.00
	WQB SUBTOTAL:			0.00
Transportation Engineering				
Traffic Signal New (Interconnect, Controller, Software, Initial Coordination, Design)	1	EA.	272,000.00	272,000
Traffic Signal Modification	1	L.S.	150,000.00	150,000
Traffic Signal Interconnect (Existing Signals Only)	0	L.F.	30.00	0
Traffic Striping/raised pavement markers	0	L.S.	3,500.00	0
Traffic Striping (DIF Street Name)	0	L.S.	--	0
Street Name Sign (Iris)	1	EA.	500.00	500
Street Name Sign (Indian)	1	EA.	500.00	500
Street Name Sign (Cosmos)	1	EA.	500.00	500
Street Name Sign (Krameria South)	1	EA.	500.00	500
Stop Sign	0	EA.	200.00	0
Signs and Posts (Krameria North)	1	EA.	200.00	200
Signs and Posts (Cosmos)	1	EA.	200.00	200
Signs and Posts (Krameria South)	1	EA.	200.00	200
Signs and Posts (Indian)	1	EA.	200.00	200
Street Sweeping Sign	0	EA.	200.00	0
Warning Markers - Type L, Type N	0	EA.	100.00	0
Traffic Control	0	L.S.	--	0
Traffic Control (DIF Street Name)	0	L.S.	--	0
Street Light PB-Adjust to Grade	0	EA.	800.00	0
	TRANSPORTATION SUBTOTAL:			424,800
Miscellaneous				
Erosion Control	0	AC	FILL IN	0
Walls - Masonry: 6' Maximum	0	L.F.	100.00	0
Walls - Retaining: 6' Maximum	0	L.F.	150.00	0
Relocate Trees	0	EA.	2,500.00	0
	MISCELLANEOUS SUBTOTAL:			0

EXHIBIT "A"
ENGINEER'S ESTIMATE

Sheet 4 of 8

PROJECT: PM35672

DATE: 06/13/13

PREPARED BY: Clement Jimenez



OFFSITE STORM DRAIN SYSTEM - RCFC LINE D & D-1

TYPE	QUANTITY	UNIT	UNIT PRICE	TOTAL
Pipe				
12" Reinforced Concrete Pipe	0	L.F.	130.00	0
18" Reinforced Concrete Pipe (Iris)	94	L.F.	140.00	13,160
18" Reinforced Concrete Pipe (Indian)	54	L.F.	140.00	7,560
24" Reinforced Concrete Pipe (Krameria South)	80	L.F.	160.00	12,800
24" Reinforced Concrete Pipe (Cosmos)	79	L.F.	160.00	12,640
30" Reinforced Concrete Pipe	0	L.F.	180.00	0
36" Reinforced Concrete Pipe (Krameria South)	164	L.F.	190.00	31,160
36" Reinforced Concrete Pipe (Cosmos)	119	L.F.	190.00	22,610
42" Reinforced Concrete Pipe w/AC (RCFC&WCD)	1356	L.F.	228.00	309,168
48" Reinforced Concrete Pipe w/A.C. (RCFC&WCD)	1162	L.F.	261.00	303,282
54" Reinforced Concrete Pipe	0	L.F.	300.00	0
60" Reinforced Concrete Pipe w/A.C. (RCFC&WCD)	659	L.F.	330.00	217,470
12" HDPE	0	L.F.	45.00	0
18" HDPE	0	L.F.	50.00	0
24" HDPE	0	L.F.	55.00	0
30" HDPE	0	L.F.	60.00	0
36" HDPE	0	L.F.	70.00	0
42" HDPE	0	L.F.	80.00	0
48" HDPE	0	L.F.	90.00	0
54" HDPE	0	L.F.	125.00	0
60" HDPE	0	L.F.	140.00	0
4" PVC SCH. 40	0	L.F.	25.00	0
4" PVC SCH. 80	0	L.F.	30.00	0
6" PVC SCH. 40	0	L.F.	30.00	0
6" PVC SCH. 80	0	L.F.	35.00	0
8" PVC SCH. 40	0	L.F.	40.00	0
8" PVC SCH. 80	0	L.F.	48.00	0
Reinforced Concrete Structure (RCFC&WCD)	310	C.Y.	700.00	217,000
Caltrans D80 (40") (RCFC&WCD)	48	C.Y.	600.00	28,800
Manholes				
Manhole No. 1	0	EA.	5000.00	0
Manhole No. 2 (RCFC&WCD)	4	EA.	6500.00	26,000
Manhole No. 3	0	EA.	6500.00	0
Manhole No. 4 (RCFC&WCD)	4	EA.	6500.00	26,000
	0		---	0
Catch Basins				
Catch Basin (3.5')	0	EA.	3100.00	0
Catch Basin (7') (Iris)	2	EA.	5500.00	11,000
Catch Basin (7') (Indian)	1	EA.	5500.00	5,500
Catch Basin (7') (Krameria South)	1	EA.	5500.00	5,500
Catch Basin (7') (Cosmos)	3	EA.	5500.00	16,500
Catch Basin (14')	0	EA.	8000.00	0
Catch Basin (21')	0	EA.	12500.00	0
Local Depressions (Iris)	2	EA.	535.00	1,070
Local Depressions (Indian)	1	EA.	535.00	535
Local Depressions (Krameria South)	1	EA.	535.00	535
Local Depressions (Cosmos)	3	EA.	535.00	1,605
24" X 24" Grate basin (Krameria South)	1	EA.	2500.00	2,500
18" X 18" Grate Basin	0	EA.	2100.00	0
6" Wide Strip Basin	0	EA.	3000.00	0
Removal/Relocation- Catch Basin	0	EA.	5000.00	0
Grated Catch Basin	0	EA.	6000.00	0
Headwall	0	EA.	5500.00	0

EXHIBIT "A"
ENGINEER'S ESTIMATE

Sheet 5 of 8

PROJECT: PM35672

DATE: 06/13/13

PREPARED BY: Clement Jimenez

OFFSITE STORM DRAIN SYSTEM - RCFC (CONTINUED)

TYPE	QUANTITY	UNIT	UNIT PRICE	TOTAL
Structures				
Transition Structure (RCFC&WCD)(Krameria South)	1	EA.	5500.00	5,500
Junction Structure (RCFC&WCD)(Krameria South)	1	EA.	6000.00	6,000
Junction Structure (Cosmos)	1	EA.	6000.00	6,000
Type IX Inlet Structure	0	EA.	2500.00	0
Inlet Structure (drop)	0	EA.	5000.00	0
Outlet Structure	0	EA.	8000.00	0
Concrete Collar (to 48") (RCFC&WCD)(Iris)	2	EA.	3000.00	6,000
Concrete Collar (to 48") (RCFC&WCD)(Indian)	1	EA.	3000.00	3,000
Headwall	0	EA.	5500.00	0
Drains				
Terrace Drain	0	S.F.	10.00	0
Down Drain	0	S.F.	10.00	0
Parkway Drain	0	EA.	3500.00	0
Under Sidewalk	0	EA.	600.00	0
Curb Outlet	0	EA.	250.00	0
"V" Gutter	0	S.F.	10.00	0
	0		---	0
Miscellaneous				
Rip Rap	0	TON	60.00	0
Concrete Pipe Slope Anchor	0	EA.	2500.00	0
	0		---	0
			SUBTOTAL:	1,298,895

EXHIBIT "A"
ENGINEER'S ESTIMATE

Sheet 6 of 8

PROJECT: PM35672

DATE: 06/13/13
PREPARED BY: Clement Jimenez



OFFSITE WATER SYSTEMS

TYPE	QUANTITY	UNIT	UNIT PRICE	TOTAL
Pipes - Water System				
4" PVC C-900 (Cosmos)	157		30.00	4,710
6" PVC C-900 (Indian)	81		40.00	3,240
8" PVC C-900 (Indian)	20		50.00	1,000
10" PVC C-900	0		55.00	0
12" PVC C-900 (Indian)	221		60.00	13,260
12" PVC C-900 (Krameria South)	1375		60.00	82,500
12" PVC C-900 (Krameria North)	62		60.00	3,720
12" PVC C-900 (Cosmos)	2606		60.00	156,360
16" PVC C-900	0		90.00	0
18" PVC C-900	0		135.00	0
20" PVC C-900	0		180.00	0
	0 L.F.		---	0
Valves - Water System				
4" Gate Valve (Indian)	2 EA.		600.00	1,200
4" Gate Valve (Cosmos)	2 EA.		600.00	1,200
6" Gate Valve	0 EA.		800.00	0
8" Gate Valve	0 EA.		1,000.00	0
10" Gate Valve	0 EA.		1,200.00	0
12" Gate Valve (Indian)	6 EA.		2,000.00	12,000
12" Gate Valve (Krameria South)	1 EA.		2,000.00	2,000
12" Gate Valve (Cosmos)	3 EA.		2,000.00	6,000
1" Air Vac Release (Krameria South)	2 EA.		2,000.00	4,000
1" Air Vac Release (Cosmos)	1 EA.		2,000.00	2,000
2" Air Vac Release	0 EA.		3,000.00	0
4" Blow Off	0 EA.		2,000.00	0
4" Blow Off (Indian)	2 EA.		2,000.00	4,000
4" Blow Off (Krameria North)	1 EA.		2,000.00	2,000
Fire Hydrants - Water System				
6" Standard Fire Hydrants	0 EA.		2,800.00	0
6" Super Fire Hydrants (Iris)	0 EA.		3,000.00	0
6" Super Fire Hydrants (Indian)	8 EA.		3,000.00	24,000
6" Super Fire Hydrants (Krameria South)	4 EA.		3,000.00	12,000
6" Super Fire Hydrants (Cosmos)	8 EA.		3,000.00	24,000
Services Connections				
1" Service	0 EA.		500.00	0
1 1/2" Service	0 EA.		1,100.00	0
2" Service	0 EA.		1,600.00	0
	0		---	0
Fittings - Water System				
Misc. Fittings 4" (Cosmos)	4		120.00	480
Misc. Fittings 6" (Krameria North)	2		160.00	320
Misc. Fittings 8" (Indian)	2		200.00	400
Misc. Fittings 10" (Indian)	2		240.00	480
Misc. Fittings 12" (Krameria South)	2		750.00	1,500
Misc. Fittings 12" (Cosmos)	4		750.00	3,000
Water Meters - Water System				
5/8" Meter	0		200.00	0
1" Meter	0		270.00	0
1 1/2" Meter	0		360.00	0
2" Meter (Cosmos)	3		455.00	1,365
	0		---	0
Hot Tap Connections - Water System				
8" Hot Tap	0 EA.		2,800.00	0
Water Service (Indian)	10 EA.		330.00	3,300
Miscellaneous - Water System				
Thrust Block	0 CY		150.00	0
Jack & Bore	0 L.F.		300.00	0
Joint at Existing 8" (Cosmos)	1 EA.		650.00	650
			SUBTOTAL:	370,685

EXHIBIT "A"
ENGINEER'S ESTIMATE

Sheet 7 of 8

PROJECT: PM35672

DATE: 06/13/13
PREPARED BY: Clement Jimenez



OFFSITE SEWER SYSTEMS

TYPE	QUANTITY	UNIT	UNIT PRICE	TOTAL
Pipes - Sewer System				
4" V.C. Pipe	0	L.F.	20.00	0
6" V.C. Pipe (Cosmos)	0	L.F.	25.00	0
8" V.C. Pipe (Krameria South)	32	L.F.	30.00	960
8" V.C. Pipe (Cosmos)	0	L.F.	30.00	0
10" V.C. Pipe (Krameria South)	926	L.F.	40.00	37,040
12" V.C. Pipe	0	L.F.	50.00	0
15" V.C. Pipe	0	L.F.	75.00	0
18" V.C. Pipe	0	L.F.	90.00	0
21" V.C. Pipe	0	L.F.	105.00	0
24" V.C. Pipe	0	L.F.	120.00	0
27" V.C. Pipe	0	L.F.	135.00	0
30" V.C. Pipe	0	L.F.	150.00	0
33" V.C. Pipe	0	L.F.	165.00	0
36" V.C. Pipe	0	L.F.	185.00	0
4" SDR - 35	0	L.F.	13.00	0
6" SDR - 35	0	L.F.	19.00	0
8" SDR - 35	0	L.F.	25.00	0
10" SDR - 35	0	L.F.	30.00	0
12" SDR - 35	0	L.F.	50.00	0
15" SDR - 35	0	L.F.	60.00	0
Concrete Encasement	0	L.F.	20.00	0
	0		---	0
Cleans Outs - Sewer System				
Clean-outs (Krameria South)	1	EA.	700.00	700
Clean-outs	0	EA.	700.00	0
Clean Out Lateral	0	EA.	120.00	0
	0		---	0
Manholes - Sewer System				
Standard Manhole 48" (Krameria South)	4	EA.	3,000.00	12,000
Standard Manhole 48" (Cosmos)	0	EA.	3,000.00	0
Standard Manhole 48" Extra Depth	0	EA.	3,500.00	0
Standard Manhole 60" (Krameria South)	1	EA.	4,500.00	4,500
Shallow Manhole	0	EA.	3,000.00	0
Adjust Manhole to Grade	0	EA.	300.00	0
Tie Into Existing Manhole	0	EA.	1,500.00	0
Rechannel Existing Manhole	0	EA.	1,500.00	0
Join Existing 8" Pipe	0	EA.	600.00	0
Join Existing 12" Pipe	0	EA.	800.00	0
	0		---	0
Miscellaneous - Sewer System				
Wyes (Krameria South)	0	EA.	90.00	0
Wyes (Cosmos)	0	EA.	90.00	0
TV Sewer	0	L.F.	1.00	0
Trench Paving	0	S.F.	5.00	0
Pavement Replacement	0	S.F.	3.00	0
Meter 5/8" W/O Service	0	EA.	200.00	0
			SUBTOTAL:	55,200

EXHIBIT "A"
ENGINEER'S ESTIMATE

Sheet 8 of 8

CITY OF MORENO VALLEY
PUBLIC WORKS DEPARTMENT - LAND DEVELOPMENT DIVISION
BOND COMPUTATION SHEET

PROJECT: PM35672 DATE: 06/13/13
PREPARED BY: Clement Jimenez

IMPROVEMENT TYPE:

PAVEMENT SECTION WORK	:	\$3,073,934
CONCRETE & OTHER STREET WORK	:	\$2,875,491
SPECIAL DISTRICTS	:	\$152,000
MORENO VALLEY UTILITIES	:	\$0
WATER QUALITY BASIN	:	\$0
TRANSPORTATION ENGINEERING	:	\$424,800
STORM DRAIN SYSTEM - RCFCD LINES	:	\$1,298,895
WATER SYSTEM	:	\$370,685
SEWER SYSTEM	:	\$55,200
MISCELLANEOUS	:	\$0
TOTAL COST (VALUE) OF IMPROVEMENTS:		\$8,251,005
+5% CONTINGENCY		\$412,550
<u>GRAND TOTAL:</u>		\$8,663,555

FAITHFUL PERFORMANCE SECURITY
SECURITY AMOUNT:

\$8,664,000

LABOR & MATERIAL SECURITY
SECURITY AMOUNT:

\$4,332,000

*The cost for securing payment of Labor and Materials is fifty (50) percent of the total cost estimate of the improvements.

This page intentionally left blank.

FAITHFUL PERFORMANCE BOND

**City of Moreno Valley
County of Riverside
State of California
(Government Code Section 66499.1)**

Public Improvements <u>\$8,664,000</u>	Project No. <u>PA07-0080 (PM 35672)</u>
Bond No. <u>SUR7403302</u>	Premium <u>\$116,964.00</u>
Surety <u>XL Specialty Insurance Company</u>	Principal <u>Panattoni Construction, Inc.</u>
Address <u>Seaview House, 70 Seaview Avenue</u>	Address <u>8775 Folsom Blvd., Suite 100</u>
City/Zip <u>Stamford, CT 06902</u>	City/Zip <u>Sacramento, CA 95826</u>

WHEREAS, the City Council of the City of Moreno Valley, County of Riverside, State of California, and Panattoni Construction, Inc. (hereinafter designated as "Principal") have entered into, or are about to enter into the attached agreement whereby Principal agrees to install and complete the above-designated public improvements, relating to **PA07-0080 (PM 35672)**, which agreement is hereby referred to and made a part hereof; and,

WHEREAS, said principal is required under the terms of said agreement to furnish bond for the faithful performance of said agreement;

NOW, THEREFORE, we the Principal, and XL Specialty Insurance Company, as Surety, are held and firmly bound to the City of Moreno Valley in the penal sum of **EIGHT MILLION SIX HUNDRED SIXTY FOUR THOUSAND AND NO/100 Dollars (***\$8,664,000.00***)**, lawful money of the United States, for the payment of which sum will and truly to be made, we bind ourselves, our heirs, successors, executors and administrator, jointly and severally, firmly by these presents.

The condition of this obligation is such that if the above bonded Principal, his or its heirs, executors, administrators, successors, or assigns, shall in all things stand to and abide by, and well and truly keep and perform the covenants, conditions and provisions in the said agreement and any alteration thereof made as therein provided, on his or specified, and in all respects according to their true intent and meaning, and shall indemnify and save harmless the City of Moreno Valley, its officers, agents and employees, as therein stipulated, then this obligation shall become null and void; otherwise, it shall be and remain in full force and effect.

As part of the obligation secured hereby, and in addition to the face amount specified therefore, there shall be included costs and reasonable expenses and fees, including reasonable attorney's fees, incurred by City in successfully enforcing such obligation, all to be taxed as costs and included in any judgment rendered.

FAITHFUL PERFORMANCE BOND (Page 2 of 2)
PROJECT NO. PA07-0080 (PM 35672)

The surety hereby stipulates and agrees that no change, extension of time, alteration or addition to the terms of the agreement or to the work to be performed thereunder or the specifications accompanying the same shall in anywise affect its obligation on this bond, and it does hereby waive notice of any such change, extension of time, alteration or addition to the terms of the agreement or to the work or to the specifications. Surety further stipulates and agrees that the provisions of Section 2845 of the Civil Code are not a condition precedent to Surety's obligations hereunder and are hereby waived by Surety.

When the work covered by the agreement is complete, the City Council of the City of Moreno Valley will accept the work and thereupon the amount of the obligation of this bond is reduced by 90%, with the remaining 10% held as security for the one-year maintenance period provided for in the agreement(s).

IN WITNESS WHEREOF, this instrument has been duly executed by the Principal and Surety above named on June 28, 2013.

NAME OF PRINCIPAL: Panattoni Construction, Inc.
Company Name

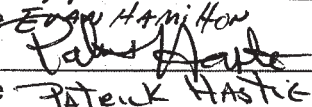
AUTHORIZED SIGNATURE(S): By  SVP
Name Erin Hamilton Title
 SVP
Name Patrick Hastic Title

NAME OF SURETY: XL Specialty Insurance Company
Company Name

AUTHORIZED SIGNATURE: 
Mary Ann Powell ITS ATTORNEY-IN-FACT

ATTACH NOTARIAL ACKNOWLEDGMENT OF SIGNATURE OF PRINCIPAL AND ATTORNEY-IN-FACT.
BOND COMPANY – ATTACH POWER OF ATTORNEY

Approved as to form:

Date: _____

City Attorney
City of Moreno Valley

W:\LandDev\MANAGEMENT ASSISTANT\Agreement Bond Packets\PA07-0080 - Faithful Performance Bond.DOC

CALIFORNIA ALL-PURPOSE ACKNOWLEDGEMENT

State of Georgia

County of Fulton

On June 28, 2013 before me, Anna Logue
Date Name and Title of Notary

personally appeared Evan Hamilton
Name and or Names of Signer(s)

Who proved to me on the basis of satisfactory evidence to be the person(s) whose name(s) is/are subscribed to the within instrument and acknowledged to me that he/she/they executed the same in his/her/their authorized capacity(ies), and that by his/her/their signature(s) on the instrument the person(s), or the entity upon behalf of which the person(s) acted, executed the instrument.

I certify under PENALTY OF PERJURY under the laws of the State of California that the foregoing paragraph is true and correct.

Witness my hand and official seal.

Signature 
Notary Public Signature
 Anna Logue

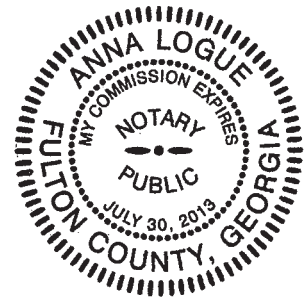

Place Notary Public Seal Above

OPTIONAL

Though the information below is not required by law, it may prove valuable to the persons relying on the document and could prevent fraudulent removal and reattachment of this form to another document.

Description of Attached Document

Title or Type of Document _____

Document Date _____ Number of Pages: _____

Signer's Name: _____

Individual
 Corporate Officer – Title(s): Senior Vice President
 Partner - Limited General
 Guardian or Conservator
 Attorney-in-Fact
 Trustee
 Other: _____
 Signer is representing _____
Panattoni Construction, Inc.

RIGHT THUMBPRINT OF SIGNER

Top of thumb

Individual
 Corporate Officer – Title(s): _____
 Partner - Limited General
 Guardian or Conservator
 Attorney-in-Fact
 Trustee
 Other: _____
 Signer is representing _____

RIGHT THUMBPRINT OF SIGNER

Top of thumb

ALL PURPOSE ACKNOWLEDGMENT

STATE OF CALIFORNIA }
COUNTY OF ORANGE }ss
}

On JULY 3, 2013, before me Judi Lowenthal, Notary Public, personally appeared

PATRICK HASTIE

who proved to me on the basis of satisfactory evidence to be the person(s) whose name(s) is/are subscribed to the within instrument and acknowledged to me that he/she/they executed the same in his/her/their authorized capacity(ies), and that by his/her/their signature(s) on the instrument the person(s), or the entity upon behalf of which the person(s) acted, executed the instrument.

I certify under PENALTY OF PERJURY under the laws of the State of California that the foregoing paragraph is true and correct.

WITNESS my hand and official seal.

Signature

Judi Lowenthal

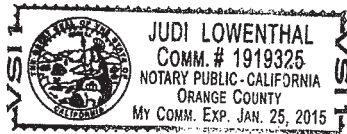

(NOTARY SEAL)

ATTENTION NOTARY: Although the information requested below is **OPTIONAL**, it could prevent fraudulent attachment of this certificate to another document.

THIS CERTIFICATE **MUST** BE ATTACHED TO THE DOCUMENT DESCRIBED BELOW.

Title of Document Type FAITHFUL PERFORMANCE BOND

Number of Pages 2 Date of Document 6/28/13

Signer(s) Other Than Named Above _____

CALIFORNIA ALL-PURPOSE ACKNOWLEDGEMENT

State of Illinois

County of Cook



On June 28, 2013 before me, Susan K. Landreth
Date Name and Title of Notary

personally appeared Mary Ann Powell
Name and or Names of Signer(s)

Who proved to me on the basis of satisfactory evidence to be the person(s) whose name(s) is/are subscribed to the within instrument and acknowledged to me that he/she/they executed the same in his/her/their authorized capacity(ies), and that by his/her/their signature(s) on the instrument the person(s), or the entity upon behalf of which the person(s) acted, executed the instrument.

I certify under PENALTY OF PERJURY under the laws of the State of California that the foregoing paragraph is true and correct.



Witness my hand and official seal.

Signature *Susan K. Landreth*
Notary Public Signature
Susan K. Landreth

Place Notary Public Seal Above

OPTIONAL

Though the information below is not required by law, it may prove valuable to the persons relying on the document and could prevent fraudulent removal and reattachment of this form to another document.

Description of Attached Document

Title or Type of Document _____

Document Date _____ Number of Pages: _____

Signer's Name: _____

- Individual
 - Corporate Officer – Title(s): _____
 - Partner - Limited General
 - Guardian or Conservator
 - Attorney-in-Fact
 - Trustee
 - Other: _____
- Signer is representing _____
XL Specialty Insurance Company

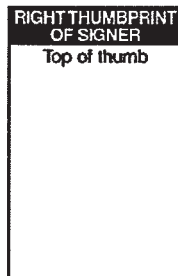

- Individual
 - Corporate Officer – Title(s): _____
 - Partner - Limited General
 - Guardian or Conservator
 - Attorney-in-Fact
 - Trustee
 - Other: _____
- Signer is representing _____

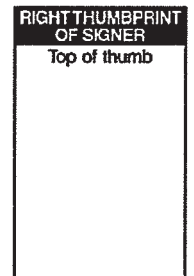



Power of Attorney
 XL Specialty Insurance Company
 Greenwich Insurance Company
 XL Reinsurance America Inc.

THIS IS NOT A BOND NUMBER
 UNLIMITED POWER OF ATTORNEY
 XL1504844

KNOW ALL MEN BY THESE PRESENTS: That XL Specialty Insurance Company, Greenwich Insurance Company, Delaware insurance companies with offices located at 505 Eagleview Blvd., Exton, PA 19341, and XL Reinsurance America Inc., a New York insurance company with offices located at 70 Seaview Avenue, Stamford, CT 06902, do hereby nominate, constitute, and appoint:

Kimberly Bragg, Ila Delman, Mary Ann Powell, Mark V. Baechle, Christine Eitel

each its true and lawful Attorney(s)-in-fact to make, execute, attest, seal and deliver for and on its behalf, as surety, and as its act and deed, where required, any and all bonds and undertakings in the nature thereof, for the penal sum of no one of which is in any event to exceed UNLIMITED.

Such bonds and undertakings, when duly executed by the aforesaid Attorney (s) - in - Fact shall be binding upon each said Company as fully and to the same extent as if such bonds and undertakings were signed by the President and Secretary of the Company and sealed with its corporate seal.

The Power of Attorney is granted and is signed by facsimile under and by the authority of the following Resolutions adopted by the Board of Directors of each of the Companies on the 5th day of October 2012.

RESOLVED, that Gary Kaplan, David Hewett, William Mills, Gregory Boal and Kevin Mirsch are hereby appointed by the Board as authorized to make, execute, seal and deliver for and on behalf of the Company, any and all bonds, undertakings, contracts or obligations in surety or co-surety with others and that the Secretary or any Assistant Secretary of the Company be and that each of them hereby is authorized to attest the execution of any such bonds, undertakings, contracts or obligations in surety or co-surety and attach thereto the corporate seal of the Company.

RESOLVED, FURTHER, that Gary Kaplan, David Hewett, William Mills, Gregory Boal and Kevin Mirsch each is hereby authorized to execute powers of attorney qualifying the attorney named in the given power of attorney to execute, on behalf of the Company, bonds and undertakings in surety or co-surety with others, and that the Secretary or any Assistant Secretary of the Company be, and that each of them is hereby authorized to attest the execution of any such power of attorney, and to attach thereto the corporate seal of the Company.

RESOLVED, FURTHER, that the signature of such officers named in the preceding resolutions and the corporate seal of the Company may be affixed to such powers of attorney or to any certificate relating thereto by facsimile, and any such power of attorney or certificate bearing such facsimile signatures or facsimile seal shall be thereafter valid and binding upon the Company with respect to any bond, undertaking, contract or obligation in surety or co-surety with others to which it is attached.

IN WITNESS WHEREOF, the XL SPECIALTY INSURANCE COMPANY and GREENWICH INSURANCE COMPANY has caused its corporate seal to be hereunto affixed, and these presents to be signed by its duly authorized officers this October 5th, 2012.

**XL SPECIALTY INSURANCE COMPANY
 GREENWICH INSURANCE COMPANY**



By:

David S. Hewett

SENIOR VICE PRESIDENT

Attest:

Toni Ann Perkins

SECRETARY

STATE OF CONNECTICUT
 COUNTY OF FAIRFIELD

On this 5th day of October, 2012, before me personally came David S. Hewett to me known, who, being duly sworn, did depose and say: that he is Senior Vice President of XL SPECIALTY INSURANCE COMPANY and GREENWICH INSURANCE COMPANY, described in and which executed the above instrument; that he knows the seals of said Companies; that the seals affixed to the aforesaid instrument is such corporate seals and were affixed thereto by order and authority of the Boards of Directors of said Companies; and that he executed the said instrument by like order.

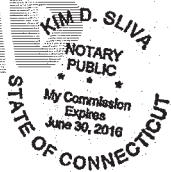

Kim D. Sliva

NOTARY PUBLIC

SB-0034 - 3/11

STATE OF CONNECTICUT
COUNTY OF FAIRFIELD

I, Toni Ann Perkins, Secretary of the XL SPECIALTY INSURANCE COMPANY and GREENWICH INSURANCE COMPANY a corporation of the State of Delaware, do hereby certify that the above and forgoing is a full, true and correct copy of Power of Attorney issued by said Company, and that I have compared same with the original and that it is a correct transcript there from and of the whole of the original and that the said Power of Attorney is still in full force

IN WITNESS WHEREOF, I have hereunto set my hand and affixed the seal of said Corporation, at the City of Hartford, this 28th day of June 2013.



Toni Ann Perkins

SECRETARY

IN WITNESS WHEREOF, XL REINSURANCE AMERICA INC. has caused its corporate seal to be hereunto affixed, and these presents to be signed by its duly authorized officers this 5th day of October, 2012.



XL REINSURANCE AMERICA INC.

by:

John Welch

SENIOR VICE PRESIDENT

Attest:

Toni Ann Perkins

SECRETARY

STATE OF CONNECTICUT
COUNTY OF FAIRFIELD

On this 5th day of October, 2012, before me personally came John P. Welch to me known, who, being duly sworn, did depose and say: that he is President & CEO of XL REINSURANCE AMERICA INC., described in which executed the above instrument; that he knows the seal of said Corporation; that the seal affixed to the aforesaid instrument is such corporate seal and was affixed thereto by order and authority of the Board of Directors of said Corporation, and that he executed the said instrument by like order.



Kim D. Sliva

NOTARY PUBLIC

STATE OF CONNECTICUT
COUNTY OF FAIRFIELD

I, Toni Ann Perkins, Assistant Secretary of the XL REINSURANCE AMERICA INC. a corporation of the State of New York, do hereby certify that the person who executed this Power of Attorney, with the rights, respectively of XL REINSURANCE AMERICA INC., the above and forgoing is a full, true and correct copy of a Power of Attorney issued by said Corporation, and that I have compared same with the original

IN WITNESS WHEREOF, I have hereunto set my hand and affixed the seal of said Corporation, at the City of Hartford, this 28th day of June 2013.



Toni Ann Perkins

SECRETARY

This Power of Attorney may not be used to execute any bond with an inception date after October 5, 2017
SB0041

THIS DOCUMENT IS PRINTED ON A BLUE BACKGROUND

This page intentionally left blank.

M A T E R I A L A N D L A B O R B O N D

**City of Moreno Valley
County of Riverside
State of California
(Government Code Section 66499.2)**

Public Improvements <u>\$4,332,000</u>	Project No. <u>PA07-0080 (PM 35672)</u>
Bond No <u>SUR7403302</u>	Premium <u>\$116,964.00</u>
Surety <u>XL Specialty Insurance Company</u>	Principal <u>Panattoni Construction, Inc.</u>
Address <u>Seaview House, 70 Seaview Avenue</u>	Address <u>8775 Folsom Blvd., Suite 201</u>
City/Zip <u>Stamford, CT 06902</u>	City/Zip <u>Sacramento, CA 95826</u>

WHEREAS, the City Council of the City of Moreno Valley, County of Riverside, State of California, and **Panattoni Construction, Inc.**, (hereinafter designated as "Principal") have entered into, or are about to enter into the attached agreement whereby Principal agrees to install and complete the above-designated public improvements, relating to **PA07-0080 (PM 35672)**, which agreement is hereby referred to and made a part hereof; and,

WHEREAS, under the terms of said agreement, principal is required before entering upon the performance of the work, to file a good and sufficient payment bond with the City of Moreno Valley to secure the claims to which reference is made in Title 15 (commencing with Section 3082) of Part 4 of Division 3 of the Civil Code of the State of California.

NOW, THEREFORE, we the Principal, and the undersigned as corporate Surety, are held and firmly bound unto the City of Moreno Valley and all contractors, subcontractors, laborers, material persons and other persons employed in the performance of the aforesaid agreement and referred to in the aforesaid Civil Code in the sum of **FOUR MILLION THREE HUNDRED THIRTY TWO THOUSAND AND NO/100 Dollars (**\$4,332,000.00**)**, lawful money of the United States, for materials furnished or labor thereon of any kind, or for amounts due under the Unemployment Insurance Act with respect to such work or labor, that said Surety will pay the same in an amount not exceeding the amount hereinabove set forth, also in case suit is brought upon this bond, will pay, in addition to the face amount hereof, costs and reasonable expenses and fees, including reasonable attorney's fees, incurred by City in successfully enforcing such obligation, to be awarded and fixed by the court, and to be taxed as costs and to be included in the judgement therein rendered.

It is hereby expressly stipulated and agreed that this bond shall inure to the benefit of any and all persons, companies and corporations entitled to file claims under Title 15 (commencing with Section 3082) of Part 4 of Division 3 of the Civil Code, so as to give a right of action to them or their assigns in any suit brought upon this bond.

MATERIAL AND LABOR BOND (Page 2 of 2)
PROJECT NO. PA07-0080 (PM 35672)

Should the condition of this bond be fully performed, then this obligation shall become null and void, otherwise it shall be and remain in full force and effect.

The Surety hereby stipulates and agrees that no change, extension of time, alteration or addition to the terms of the agreement or the specifications accompanying the same shall in any manner affect its obligation on this bond, and it does hereby waive notice of any such change, extension, alteration or addition. Surety further stipulates and agrees that the provision of Section 2845 of the Civil Code are not a condition precedent to the Surety's obligations hereunder and hereby waived by the Surety.

In witness whereof, this instrument has been duly executed by the Principal and Surety above named, on June 28, 2013.

NAME OF PRINCIPAL: Panattoni Construction, Inc.
Company Name

AUTHORIZED SIGNATURE(S):

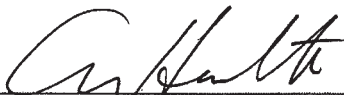
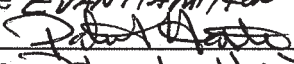
	<u>SVP</u>
Name <u>Evan Hamilton</u>	Title
	<u>Sev.P.</u>
Name <u>Patrick Hastic</u>	Title

NAME OF SURETY: XL Specialty Insurance Company
Company Name

AUTHORIZED SIGNATURE: Mary Ann Powell
Mary Ann Powell ITS ATTORNEY-IN-FACT

ATTACH NOTARIAL ACKNOWLEDGMENT OF SIGNATURE OF PRINCIPAL AND ATTORNEY-IN-FACT.
BOND COMPANY - ATTACH POWER OF ATTORNEY

Approved as to form:
Date: _____

City Attorney
City of Moreno Valley

W:\LandDev\MANAGEMENT ASSISTANT\Agreement Bond Packets\PA07-0080 - Material Labor Bond.DOC

CALIFORNIA ALL-PURPOSE ACKNOWLEDGEMENT

State of Georgia

County of Fulton



On July 3, 2013 before me, Anna Logue
Date Name and Title of Notary

personally appeared Evan Hamilton
Name and or Names of Signer(s)

Who proved to me on the basis of satisfactory evidence to be the person(s) whose name(s) is/are subscribed to the within instrument and acknowledged to me that he/she/they executed the same in his/her/their authorized capacity(ies), and that by his/her/their signature(s) on the instrument the person(s), or the entity upon behalf of which the person(s) acted, executed the instrument.

I certify under PENALTY OF PERJURY under the laws of the State of California that the foregoing paragraph is true and correct.

Witness my hand and official seal

Signature 
Notary Public Signature
Anna Logue

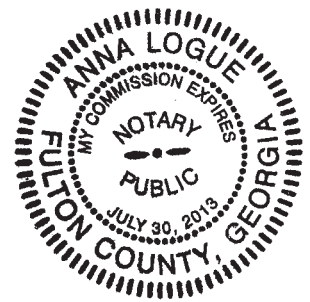

Place Notary Public Seal Above

OPTIONAL

Though the information below is not required by law, it may prove valuable to the persons relying on the document and could prevent fraudulent removal and reattachment of this form to another document.

Description of Attached Document

Title or Type of Document _____

Document Date _____ Number of Pages: _____

Signer's Name: _____

Individual
 Corporate Officer – Title(s): Senior Vice President
 Partner - Limited General
 Guardian or Conservator
 Attorney-in-Fact
 Trustee
 Other: _____
Signer is representing Panattoni Construction, Inc.

Individual
 Corporate Officer – Title(s): _____
 Partner - Limited General
 Guardian or Conservator
 Attorney-in-Fact
 Trustee
 Other: _____
Signer is representing _____

ALL PURPOSE ACKNOWLEDGMENT

STATE OF CALIFORNIA }
COUNTY OF ORANGE }ss
}

On JULY 3, 2013, before me Judi Lowenthal, Notary Public, personally appeared

PATRICK HASTIE

who proved to me on the basis of satisfactory evidence to be the person(s) whose name(s) is/~~are~~ subscribed to the within instrument and acknowledged to me that he/~~she/they~~ executed the same in his/~~her/their~~ authorized capacity(ies), and that by his/~~her/their~~ signature(s) on the instrument the person(s), or the entity upon behalf of which the person(s) acted, executed the instrument.

I certify under PENALTY OF PERJURY under the laws of the State of California that the foregoing paragraph is true and correct.

WITNESS my hand and official seal.

Signature

Judi Lowenthal

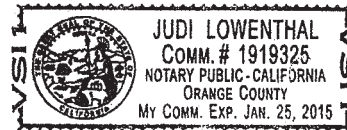

(NOTARY SEAL)

ATTENTION NOTARY: Although the information requested below is OPTIONAL, it could prevent fraudulent attachment of this certificate to another document.

THIS CERTIFICATE **MUST** BE ATTACHED TO THE DOCUMENT DESCRIBED BELOW.

Title of Document Type MATERIAL & LABOR BOND

Number of Pages 2 Date of Document 6/28/13

Signer(s) Other Than Named Above _____

CALIFORNIA ALL-PURPOSE ACKNOWLEDGEMENT

State of Illinois

County of Cook



On June 28, 2013 before me, Susan K. Landreth
Date Name and Title of Notary

personally appeared Mary Ann Powell
Name and or Names of Signer(s)

Who proved to me on the basis of satisfactory evidence to be the person(s) whose name(s) is/are subscribed to the within instrument and acknowledged to me that he/she/they executed the same in his/her/their authorized capacity(ies), and that by his/her/their signature(s) on the instrument the person(s), or the entity upon behalf of which the person(s) acted, executed the instrument.

I certify under PENALTY OF PERJURY under the laws of the State of California that the foregoing paragraph is true and correct.

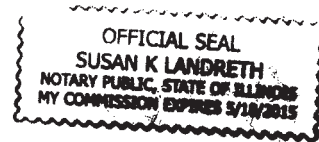

Witness my hand and official seal.

Signature *Susan K. Landreth*
Notary Public Signature
Susan K. Landreth

Place Notary Public Seal Above

OPTIONAL

Though the information below is not required by law, it may prove valuable to the persons relying on the document and could prevent fraudulent removal and reattachment of this form to another document.

Description of Attached Document

Title or Type of Document _____

Document Date _____ Number of Pages: _____

Signer's Name: _____

- Individual
 - Corporate Officer – Title(s): _____
 - Partner - Limited General
 - Guardian or Conservator
 - Attorney-in-Fact
 - Trustee
 - Other: _____
- Signer is representing _____
 XL Specialty Insurance Company

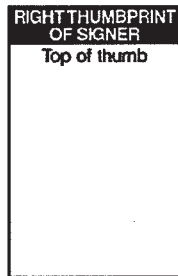

- Individual
 - Corporate Officer – Title(s): _____
 - Partner - Limited General
 - Guardian or Conservator
 - Attorney-in-Fact
 - Trustee
 - Other: _____
- Signer is representing _____





Power of Attorney
 XL Specialty Insurance Company
 Greenwich Insurance Company
 XL Reinsurance America Inc.

THIS IS NOT A BOND NUMBER
 UNLIMITED POWER OF ATTORNEY
 XL1504843

KNOW ALL MEN BY THESE PRESENTS: That XL Specialty Insurance Company, Greenwich Insurance Company, Delaware insurance companies with offices located at 505 Eagleview Blvd., Exton, PA 19341, and XL Reinsurance America Inc., a New York insurance company with offices located at 70 Seaview Avenue, Stamford, CT 06902, do hereby nominate, constitute, and appoint:

Kimberly Bragg, Ila Delman, Mary Ann Powell, Mark V. Baechle, Christine Eitel

each its true and lawful Attorney(s)-in-fact to make, execute, attest, seal and deliver for and on its behalf, as surety, and as its act and deed, where required, any and all bonds and undertakings in the nature thereof, for the penal sum of no one of which is in any event to exceed UNLIMITED.

Such bonds and undertakings, when duly executed by the aforesaid Attorney (s) - in - Fact shall be binding upon each said Company as fully and to the same extent as if such bonds and undertakings were signed by the President and Secretary of the Company and sealed with its corporate seal.

The Power of Attorney is granted and is signed by facsimile under and by the authority of the following Resolutions adopted by the Board of Directors of each of the Companies on the 5th day of October 2012.

RESOLVED, that Gary Kaplan, David Hewett, William Mills, Gregory Boal and Kevin Mirsch are hereby appointed by the Board as authorized to make, execute, seal and deliver for and on behalf of the Company, any and all bonds, undertakings, contracts or obligations in surety or co-surety with others and that the Secretary or any Assistant Secretary of the Company be and that each of them hereby is authorized to attest the execution of any such bonds, undertakings, contracts or obligations in surety or co-surety and attach thereto the corporate seal of the Company.

RESOLVED, FURTHER, that Gary Kaplan, David Hewett, William Mills, Gregory Boal and Kevin Mirsch each is hereby authorized to execute powers of attorney qualifying the attorney named in the given power of attorney to execute, on behalf of the Company, bonds and undertakings in surety or co-surety with others, and that the Secretary or any Assistant Secretary of the Company be, and that each of them is hereby authorized to attest the execution of any such power of attorney, and to attach thereto the corporate seal of the Company.

RESOLVED, FURTHER, that the signature of such officers named in the preceding resolutions and the corporate seal of the Company may be affixed to such powers of attorney or to any certificate relating thereto by facsimile, and any such power of attorney or certificate bearing such facsimile signatures or facsimile seal shall be thereafter valid and binding upon the Company with respect to any bond, undertaking, contract or obligation in surety or co-surety with others to which it is attached.

IN WITNESS WHEREOF, the XL SPECIALTY INSURANCE COMPANY and GREENWICH INSURANCE COMPANY has caused its corporate seal to be hereunto affixed, and these presents to be signed by its duly authorized officers this October 5th, 2012.

**XL SPECIALTY INSURANCE COMPANY
 GREENWICH INSURANCE COMPANY**



By:

David S. Hewett

SENIOR VICE PRESIDENT

Attest:

Toni Ann Perkins

SECRETARY

STATE OF CONNECTICUT
 COUNTY OF FAIRFIELD

On this 5th day of October, 2012, before me personally came David S. Hewett to me known, who, being duly sworn, did depose and say: that he is Senior Vice President of XL SPECIALTY INSURANCE COMPANY and GREENWICH INSURANCE COMPANY, described in and which executed the above instrument; that he knows the seals of said Companies; that the seals affixed to the aforesaid instrument is such corporate seals and were affixed thereto by order and authority of the Boards of Directors of said Companies; and that he executed the said instrument by like order.

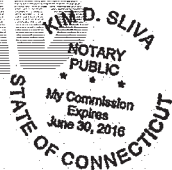

Kim D. Sliva

NOTARY PUBLIC

SB-0034 - 3/11

STATE OF CONNECTICUT
COUNTY OF FAIRFIELD

I, Toni Ann Perkins, Secretary of the XL SPECIALTY INSURANCE COMPANY and GREENWICH INSURANCE COMPANY a corporation of the State of Delaware, do hereby certify that the above and forgoing is a full, true and correct copy of Power of Attorney issued by said Company, and that I have compared same with the original and that it is a correct transcript there from and of the whole of the original and that the said Power of Attorney is still in full force

IN WITNESS WHEREOF, I have hereunto set my hand and affixed the seal of said Corporation, at the City of Hartford, this 28 day of June 2013.



Toni Ann Perkins

SECRETARY

IN WITNESS WHEREOF, XL REINSURANCE AMERICA INC. has caused its corporate seal to be hereunto affixed, and these presents to be signed by its duly authorized officers this 5th day of October, 2012.



XL REINSURANCE AMERICA INC.

by:

John P. Welch

SENIOR VICE PRESIDENT

Attest:

Toni Ann Perkins

SECRETARY

STATE OF CONNECTICUT
COUNTY OF FAIRFIELD

On this 5th day of October, 2012, before me personally came John P. Welch to me known, who, being duly sworn, did depose and say: that he is President & CEO of XL REINSURANCE AMERICA INC., described in which executed the above instrument; that he knows the seal of said Corporation; that the seal affixed to the aforesaid instrument is such corporate seal and was affixed thereto by order and authority of the Board of Directors of said Corporation, and that he executed the said instrument by like order.



Kim D. Sliva

NOTARY PUBLIC

STATE OF CONNECTICUT
COUNTY OF FAIRFIELD

I, Toni Ann Perkins, Assistant Secretary of the XL REINSURANCE AMERICA INC. a corporation of the State of New York, do hereby certify that the person who executed this Power of Attorney, with the rights, respectively of XL REINSURANCE AMERICA INC., the above and forgoing is a full, true and correct copy of a Power of Attorney issued by said Corporation, and that I have compared same with the original

IN WITNESS WHEREOF, I have hereunto set my hand and affixed the seal of said Corporation, at the City of Hartford, this 28 day of June 2013.



Toni Ann Perkins

SECRETARY

This Power of Attorney may not be used to execute any bond with an inception date after October 5, 2017
SB0041

THIS DOCUMENT IS PRINTED ON A BLUE BACKGROUND

This page intentionally left blank.

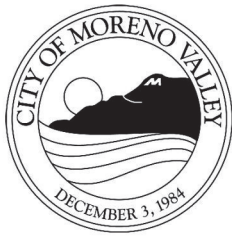

APPROVALS	
BUDGET OFFICER	<i>me</i>
CITY ATTORNEY	<i>SMB</i>
CITY MANAGER	<i>D</i>

Report to City Council

TO: Mayor and City Council

FROM: Ahmad R. Ansari, P.E., Public Works Director/City Engineer

AGENDA DATE: August 27, 2013

TITLE: PA13-0012 – APPROVAL OF PROPOSED RESOLUTION FOR THE VACATION OF A PORTION OF JOY STREET FROM CACTUS AVENUE TO BRODIAEA AVENUE

RECOMMENDED ACTION

Recommendations:

1. Adopt the Resolution No. 2013-71, vacating a portion of Joy Street.
2. Direct the City Clerk to certify said resolution and transmit a copy of the resolution to the County Recorder's office for recording.

ADVISORY BOARD/COMMISSION RECOMMENDATION

The Planning Commission is scheduled to review the vacation of Joy Street at its August 22, 2013 meeting. The results of the Planning Commission, if any, will be orally reported at the Council meeting.

BACKGROUND

On December 11, 2012, the City Council approved PA12-0020 an Amended Plot Plan to add 507,720 SF to an existing 779,016 SF warehouse building for a total of 1,286,736 SF on an 18.6 acre site.

On July 23, 2013, the Community & Economic Development Director of the City of Moreno Valley approved PA13-0012, a Tentative Parcel Map for the 507,720 square foot expansion of the existing distribution warehouse building on approximately 18.6 acres. The project is located at the west side of Graham Street, between Cactus Avenue and Brodiaea Avenue. The project conditions of approval require the vacation

of Joy Street in order to accommodate the project's proposed building expansion. The recently approved plot plan requires the same condition of approval.

City staff requires that the vacation be completed prior to issuance of building permits as per the conditions of approval. However, for the purpose of removing unwanted encumbrances from the project site in advance of the design drawings, the developer is requesting the vacation at this time. In addition, as part of the purchase and sales agreement between the private parties, the vacation of Joy Street is required in order for the exchange of property to move forward.

DISCUSSION

The proposed building expansion will enlarge the existing structure and parking area in the westerly direction, across what is now Joy Street. By way of the Tentative Parcel Map approved as PA13-0012, the existing parcel and the additional property needed for the expansion will be merged into a single lot following the proposed vacation. As the proposed building expansion will be constructed over Joy Street, the vacation of this portion of the roadway is necessary to allow for the requested business expansion.

At present, the portion of Joy Street to be vacated is fully improved. Utility Coordination letters were sent to all utility companies that may exist within the portion of the street to be vacated. There is currently an existing sewer main within Joy Street which will be abandoned upon the completion of a new alternate system routed around the proposed expansion area. The developer is coordinating with Eastern Municipal Water District (EMWD) and staff has received correspondence indicating their support of the vacation. In addition, Moreno Valley Utility has some conduits servicing the street lights within the portion of Joy Street to be vacated. These facilities will be removed with the other public improvements within this section of roadway per the conditions of approval. The proposed vacation will continue to reserve the rights and easements within the right-of-way.

Therefore, in accordance with the Streets & Highway Code, staff is recommending the vacation of Joy Street as described and shown in the exhibits attached to the proposed resolution for the following reasons: 1) the vacation would not cut off access to any adjacent properties 2) the street will be impassable to vehicular traffic following the expansion of the existing building and 3) the right-of-way will be considered excess right-of-way and not required for street purposes.

ALTERNATIVES

1. Adopt the proposed resolution, vacating a portion of Joy Street. *The said portion of right-of-way is no longer, nor will be in the future, useful for road or landscaping purposes.*
2. Do not adopt the proposed resolution, vacating a portion of Joy Street. *The said portion of excess right-of-way will remain as public right-of-way, and the proposed building expansion will not be able to move forward. This alternative would prohibit the developer from developing per the previously approved project entitlements.*

NOTIFICATION

Written notice of the intent to vacate Joy Street has been provided to the various utility companies, in addition to those businesses within 300-feet of the project boundaries. The public has been notified by publication in the newspaper, the posting of a large-scale notice on the project site and through the agenda.

ATTACHMENTS

- Attachment 1 – Vicinity Map
- Attachment 2 – Proposed Resolution

Prepared By:
 Mark W. Sambito, P.E.
 Engineering Division Manager

Department Head Approval:
 Ahmad R. Ansari, P.E.
 Public Works Director/City Engineer

Council Action	
Approved as requested:	Referred to:
Approved as amended:	For:
Denied:	Continued until:
Other:	Hearing set for:

This page intentionally left blank.

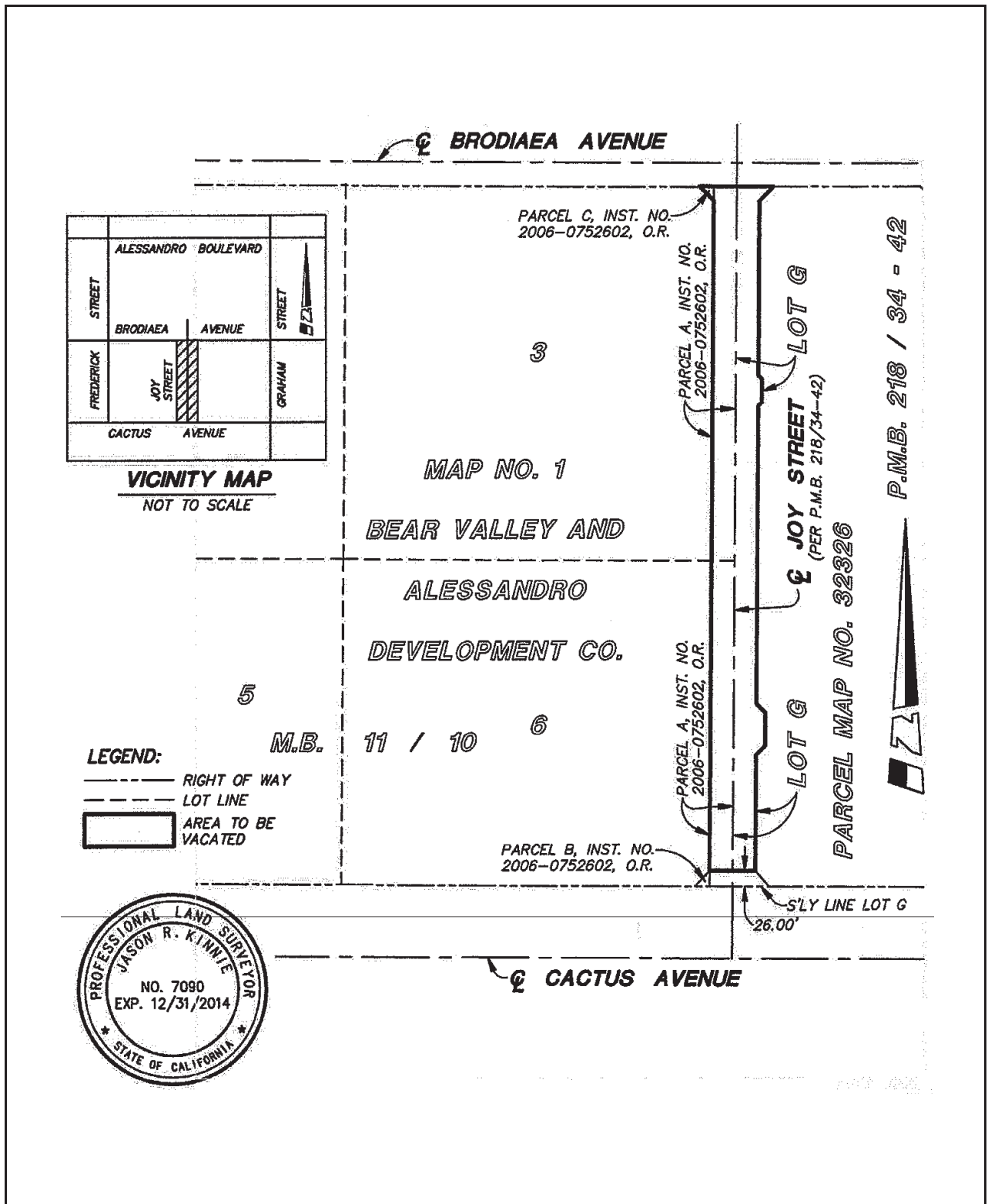

CITY OF MORENO VALLEY
 PUBLIC WORKS DEPARTMENT - LAND DEVELOPMENT

PA13-0012

This page intentionally left blank.

RESOLUTION NO. 2013-71

A RESOLUTION OF THE CITY COUNCIL OF THE CITY OF MORENO VALLEY, CALIFORNIA, ORDERING THE VACATION OF A PORTION OF JOY STREET FROM CACTUS AVENUE TO BRODIAEA AVENUE

WHEREAS, the City Council of the City of Moreno Valley, California, acquired right-of-way easements for road and public utility purposes on Joy Street; and

WHEREAS, a portion of this right-of-way is no longer, nor in the future will be, useful for road and public utility purposes; and

WHEREAS, the public improvements which exist on said portion of right-of way will be removed; and

NOW, THEREFORE, THE CITY COUNCIL OF THE CITY OF MORENO VALLEY, CALIFORNIA, DOES HEREBY RESOLVE AS FOLLOWS:

Section 1

That pursuant to the provisions of Chapter 4, Part 3, of Division 9 of the Streets and Highways Code of the State of California, designated the "Public Streets, Highways, and Service Easements Vacation Law," the following described portion of right-of way is vacated and abandoned:

That said portion of Joy Street in the City of Moreno Valley, County of Riverside, State of California described in the attached legal description and illustrated on the plat, attached hereto and made a part hereof, marked Exhibits "A" and "B", respectively.

Excepting and reserving from the vacation any easement and fee right-of-way for existing public utilities and public service facilities, together with the right to maintain, operate, replace, remove or renew such facilities, pursuant to Section 8340 of the Streets and Highway Code.

Section 2

That pursuant to the provisions of Sections 831 of Title 3 and 1112 of Title 4, Part 2, Division 2 of the California Civil Code of the State of California, title to the above-described portion of Joy Street revert to the owner of the underlying fee thereof, free from use as an easement for drainage purposes except as noted in Section 1.

Section 3

That the City Clerk of the City of Moreno Valley, California, shall cause a certified copy of this Resolution to be recorded in the office of the Recorder for the County of Riverside, California.

APPROVED AND ADOPTED this 27th day of August, 2013.

Mayor of the City of Moreno Valley

ATTEST:

City Clerk

APPROVED AS TO FORM:

City Attorney

RESOLUTION JURAT

STATE OF CALIFORNIA)
COUNTY OF RIVERSIDE) ss.
CITY OF MORENO VALLEY)

I, Jane Halstead, City Clerk of the City of Moreno Valley, California, do hereby certify that Resolution No. 2013-71 was duly and regularly adopted by the City Council of the City of Moreno Valley at a regular meeting thereof held on the 27th day of August, 2013 by the following vote:

AYES:

NOES:

ABSENT:

ABSTAIN:

(Council Members, Mayor Pro Tem and Mayor)

CITY CLERK

(SEAL)

EXHIBIT A
STREET VACATION
LEGAL DESCRIPTION

That portion of Joy Street shown as Lot G of Parcel Map No. 32326, in the City of Moreno Valley, County of Riverside, State of California, as shown on the map recorded August 15, 2006 in Book 218, Pages 34 through 42, inclusive of Parcel Maps, in the office of the County Recorder of said County lying Southerly of Brodiaea avenue and Northerly of Cactus Avenue, together with that portion of Joy Street described as Parcels A, B and C in the document recorded October 12, 2006 as Instrument Number 2006-0752602 of Official Records, in said office of the County Recorder.

Excepting therefrom that portion lying Southerly of a line being parallel with and 26.00 feet Northerly of the Southerly line of said Lot G.

Prepared by me or under my supervision.



JASON R. KINNIE, PLS 7090



PA12-0020
R110244.24 (D)
07-23-13

jrk

Page 1 of 1

4
Resolution No. 2013-71
Date Adopted: August 27, 2013

EXHIBIT 'B'
STREET VACATION PLAT

SHEET 1 OF 1

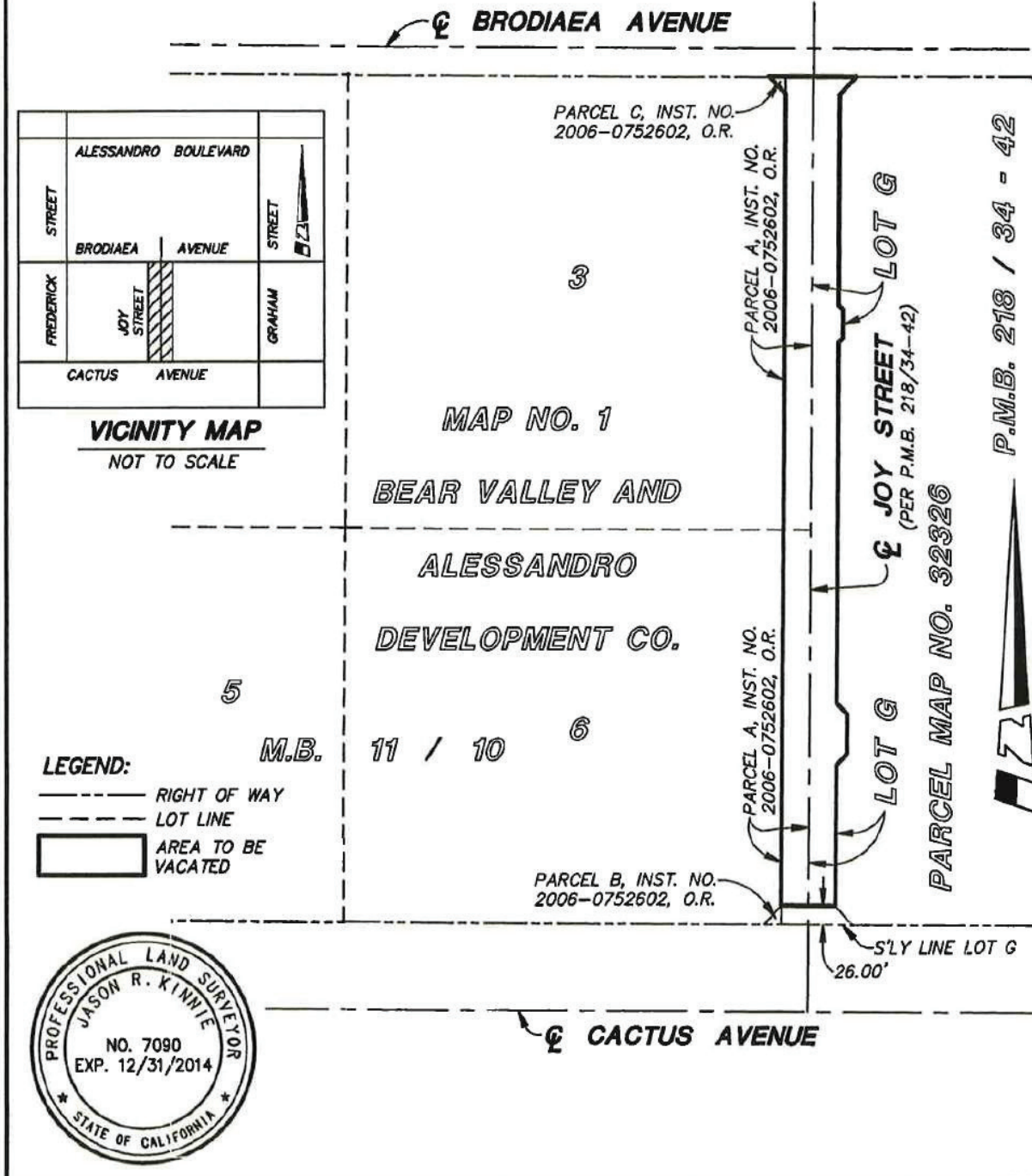

LEGEND:
 - - - - - RIGHT OF WAY
 - - - - - LOT LINE
 [Hatched Box] AREA TO BE VACATED



HUITT-ZOLLARS
 Huitt-Zollars, Inc. Irvine
 2603 Main Street, Suite 400, Irvine, CA 92614
 Phone (949) 988-5815 Fax (949) 988-5820

APPROVED BY  07-23-2013

SKETCH TO ACCOMPANY
 A LEGAL DESCRIPTION

EXHIBIT 'B'

SCALE	1"=200'
DRAWN BY	DWM
CHECKED BY	JLG
DATE	7/23/2013
JOB NO.	R110244.24

5
 Resolution No. 2013-71
 Date Adopted: August 27, 2013

Item No. A.13

This page intentionally left blank.

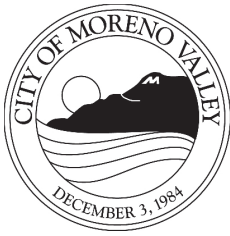

APPROVALS	
BUDGET OFFICER	<i>me</i>
CITY ATTORNEY	<i>SMB</i>
CITY MANAGER	<i>d</i>

Report to City Council

TO: Mayor and City Council

FROM: Thomas M. DeSantis, Assistant City Manager

AGENDA DATE: August 27, 2013

TITLE: RECOMMENDATION TO ESTABLISH THE CLASSIFICATION OF RECYCLING SPECIALIST IN THE PUBLIC WORKS DEPARTMENT

RECOMMENDED ACTION

Recommendation:

1. Adopt the new position, class specification and salary range of the Recycling Specialist in the Public Works Department.

BACKGROUND

The FY 2013/14 City Budget, adopted on June 11, 2013, authorized a Recycling Specialist Position in the Public Works Department pending development of a Classification Specification to be developed in coordination with the Human Resources Department.

DISCUSSION

Authorization for a Recycling Specialist position within the City's FY 2013/14 Budget funds a career, full-time Recycling Specialist (salary grade 16) in lieu of the two existing temporary, part-time Intern positions within the Solid Waste Program. Replacing part-time positions with a single career position will promote program continuity and improved support for the City's Recycling Program.

The Solid Waste/Recycling Program currently has only one full-time Management Analyst as the sole career position associated with this program. Given the specialized nature of this program, and the need to ensure compliance with State of California regulations, it is important to ensure adequate staff support for the state-mandated Recycling Program. The addition of a Full-Time Career Recycling Specialist will

accommodate this need. The position will be funded by the Used Oil Recycling Grant, Beverage Container Recycling Grant, and Solid Waste (General Fund) budget with a funding split of 44% (\$27,000), 44% (\$27,000), and 12% (\$7,000), respectively. The position would utilize approximately 60% of the funds available from the (2) grants and the remainder would remain available for educational outreach efforts. Funding for this position was approved in the FY 2013/14 - 2014/15 budgets.

The recommended Classification Specification and salary range are consistent with similar classifications in the County of Riverside’s recycling program.

ALTERNATIVES

1. Approve the Recycling Specialist position and establish the job title, class specification, and salary range for the new classification. *Staff recommends this alternative.*

2. Not approve the Recycling Specialist position. *Staff does not recommend this alternative.*

FISCAL IMPACT

No additional funding is required. Funding for this position is included in the FY 2013/14 - 2014/15 budget.

The salary grade for the Recycling Specialist position is proposed at Grade 16 (\$40,777 - \$57,411). The position would be funded by the Used Oil Recycling Grant, Beverage Container Recycling Grant, and Solid Waste (General Fund) budget. The position would utilize approximately 60% of the funds available from the (2) grants and the remainder would remain available for educational outreach efforts.

ATTACHMENTS

Attachment 1 – Class Specification

Approved By:
Thomas M. DeSantis
Assistant City Manager

Concurred By:
Robert Lemon
Maintenance & Operations Division Manager

Council Action	
Approved as requested:	Referred to:
Approved as amended:	For:
Denied:	Continued until:
Other:	Hearing set for:

City of Moreno Valley

Date Council Approved _____

Date Effective _____

CLASS SPECIFICATION
Recycling Specialist

GENERAL PURPOSE

Under general supervision, to assist with the development and implementation of the City's Solid Waste and Recycling Program; to participate in all phases of recycling programs; prepare and make presentations and make recycling educational materials available to all segments of the public and other agencies; to research, develop, present and promote recycling information and programs; to assist with management and administration of the City's solid waste collection program and associated hauler franchise agreement; and to do other work as required.

DISTINGUISHING CHARACTERISTICS

Recycling Specialists perform a variety of specialized tasks in providing assistance with the City's Solid Waste and Recycling Program, and is characterized by responsibility to develop and implement projects to accomplish the City's goals of recycling and waste reduction.

ESSENTIAL DUTIES AND RESPONSIBILITIES

The duties listed below are intended only as illustrations of the various types of work that may be performed. The omission of specific statements of duties does not exclude them from the position if the work is similar, related or a logical assignment to this class.

1. Assists with the administration of citywide recycling programs; coordinates recycling efforts with private and public agencies;
2. Conducts grant fund research and prepares or evaluates draft applications; conducts waste stream analyses and audits.
3. Produces brochures and other marketing material to promote recycling.
4. Researches and reports on legislation that affects recycling markets and processes.
5. Develops and implements detailed funding plans.
6. Conducts and participates in waste assessments; prepares statistical reports on waste characterization and waste generation.
7. Conducts promotional events; makes presentations to promote recycling.
8. Prepares and presents educational recycling programs.
9. Acts as liaison between City recycling programs and staff.
10. Assist Solid Waste & Recycling Program staff by attending meetings and providing presentations.

OTHER DUTIES

1. Assists with identifying funding resources to support program objectives; assists with the development of grant proposals and funding applications; assists with preparation of City Council resolutions and other related reports; assists with the administration of contracts and assists with the monitoring of programs to ensure contract requirements; assists with the preparation of expenditure and grant reports as required by funding agencies.
2. Assists with the preparation of the annual Solid Waste Rate Adjustment and delinquent account placement for action by the City Council; assists with responding to citizen concerns and complaints regarding the solid waste collection program.

QUALIFICATIONS

Knowledge of:

1. Principals, practices and methods of program, administrative and organizational analysis.
2. Federal, state and local laws, regulations and court decisions applicable to assigned areas of responsibility.
3. Principles and practices of public outreach and involvement, including marketing principles and practices.
4. Principles and practices of sound business communication.
5. Principles, practices and techniques of group process facilitation and conflict resolution.

Ability to:

1. Assist with the planning, organizing, and managing of a variety of complex program functions and activities to achieve Solid Waste Management program goals and objectives.
2. Collect, evaluate and interpret appropriate and applicable data, either in statistical or narrative form.
3. Coordinate program activities with multiple stakeholders and facilitate development of partnership and multi-agency agreements.
4. Understand, interpret, explain and apply laws, regulations, ordinances and policies applicable to Solid Waste Management program responsibilities.
5. Prepare clear, concise and comprehensive reports, correspondence and other documents appropriate to the audience.
6. Present conclusions and recommendations clearly, logically and persuasively to both internal and external program stakeholders.
7. Ensure the maintenance of all requires files, records and documentation.
8. Exercise tact and diplomacy in dealing with difficult and sensitive people, issues and situations.

9. Establish and maintain effective working relationships with managers at all levels, staff, representatives of other public agencies, executive management of contractors, property and business owners, the public and others encountered in the course of work.
10. Lift, carry and move boxes and files weighing 25 pounds or more.

Education, Training and Experience:

A typical way of obtaining the knowledge, skills and abilities outlined above is graduation from high school or GED equivalent, supplemented by graduation from an accredited college with a Bachelors' degree in Environmental Sciences, Public or Business Administration or a closely related field; and at least one year of progressively responsible experience in the administration, development or implementation of public or private recycling programs or resource recovery programs or an equivalent combination of training and experience.

Licenses; Certificates; Special Requirements:

A valid California driver's license and the ability to maintain insurability under the City's vehicle insurance policy.

PHYSICAL AND MENTAL DEMANDS

The physical and mental demands described here are representative of those that must be met by an employee to successfully perform the essential functions of this class. Reasonable accommodations may be made to enable individuals with disabilities to perform the essential functions.

Physical Demands

While performing the duties of this job, employees are regularly required to stand, walk or sit; talk or hear, both in person and by telephone; and use hands to operate, finger, handle or feel computers, office equipment, operate objects or controls; and to reach with hands and arms. Employees are regularly required to kneel, stoop, bend, or balance, and lift up to 25 pounds, and occasionally lift up to 50 pounds.

Specific vision abilities required are close vision, distance vision, peripheral vision and the ability to adjust focus.

Mental Demands

While performing the duties of this class, incumbents are regularly required to use written and oral communication skills; read, interpret and analyze data and information; use math and mathematical reasoning; analyze and solve problems; observe and interpret people and situations; learn and apply new information; perform detailed work on multiple, concurrent tasks; work under deadlines and interact with supervisors, clients, management agents, property owners, coworkers, the public and others encountered in the course of work.

WORK ENVIRONMENT

The work environment characteristics described here are representative of those an employee encounters while performing the essential functions of this class. Reasonable accommodations may be made to enable individuals with disabilities to perform the essential functions.

Employees work under normal office conditions involving a high volume of telephone calls and in-person client interactions; the noise level is moderate. Occasionally, employees are required to work in outdoor weather conditions.

**MINUTES - REGULAR MEETING OF JULY 9, 2013 (Report
of: City Clerk Department)**

Recommendation: Approve as submitted.

SEE AGENDA ITEM A.2

This page intentionally left blank.

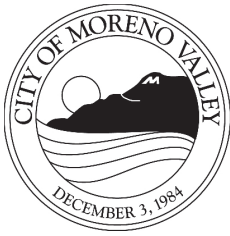

APPROVALS	
BUDGET OFFICER	<i>me</i>
CITY ATTORNEY	<i>SMB</i>
CITY MANAGER	<i>d</i>

Report to City Council

TO: Mayor and City Council, acting in their respective capacities as the President and Members of the Board of Directors of the Moreno Valley Community Services District

FROM: Michael McCarty, Director of Parks and Community Services

AGENDA DATE: August 27, 2013

TITLE: REPLACEMENT OF PLAY STRUCTURES AND PLAYGROUND SURFACING AT FAIRWAY PARK, EL POTRERO PARK, AND WESTBLUFF PARK

RECOMMENDED ACTION

Recommendations:

1. Award Purchase Order to Miracle Recreation Equipment Company, 8445 Solution Center, Chicago, IL 60677-8004 for material and labor to replace play structures and playground surfacing at Fairway Park, El Potrero Park, and Westbluff Park.
2. Authorize the Purchasing Manager to execute a purchase order in an amount not to exceed \$381,928.11 as appropriated in FY13/14, in GL account 3006-50-57-80007-720199, project number 807 0004 50 57 3006Q.
3. Authorize the issuance of a Purchase Order to Miracle Recreation Equipment Company, in the amount of \$381,928.11 (\$356,928.11 for the bid amount plus 7% contingency) when the contract has been signed by all parties.
4. Authorize the Parks and Community Services Director to execute any subsequent change orders to the contract with Miracle Recreation Equipment Company, up to but not to exceed the Purchase Order contingency of \$25,000 subject to the approval of the City Attorney.
5. Authorize the Parks and Community Services Director to accept the improvements into the Community Services District's maintained system upon acceptance of the improvements as complete.

ADVISORY BOARD/COMMISSION RECOMMENDATION

Parks and Recreation Commission reviewed and recommended the Capital Improvement Plan, including this project on March 8, 2012.

BACKGROUND

In order to comply with the California Code of Regulations, Health and Safety Codes, American Society for Testing and Materials (ASTM) and the U.S. Consumer Products Safety Commission (CPSC), play structures that are not compliant need to be retrofitted and/or replaced to be in compliance. Retrofitting is not an option in these cases, since the play equipment at these sites was discontinued in the 1990's. Several sites have been identified for replacement in the 5-year CIP, including Fairway Park, El Potrero Park, and Westbluff Park.

Miracle Recreation Equipment Company's play equipment is part of the Parks and Community Services Department's specified standards for tot lots and playgrounds. The play equipment being replaced was manufactured by Miracle Recreation Equipment Company. Additionally, Miracle Recreation Equipment Company is the exclusive supplier for Fibar® ADA compliant surfacing used in City parks. Fibar® is the standard specification for loose fill engineered wood fiber for City parks.

DISCUSSION

Project materials and labor costs have all been publically bid utilizing the HGAC (Houston-Galveston Area Council government-to-government procurement service) cooperative bidding process. Miracle Recreation Equipment Company was the low bidder for all components that are being contracted for.

In order to maintain and ensure the continuity of adopted park standards and compliance with the State and Federal codes and regulations, staff recommends that Miracle Recreation Equipment Company provide the play structures, surfacing, and this service during installation of the new structures at Fairway Park, El Potrero Park, and Westbluff Park.

ALTERNATIVES

1. Award Purchase Order to Miracle Recreation Equipment Company, 8445 Solution Center, Chicago, IL 60677-8004 for material and labor to replace play structures and playground surfacing at Fairway Park, El Potrero Park, and Westbluff Park, and authorize the Purchasing Manager to execute a purchase order in an amount not to exceed \$381,928.11 as appropriated in FY13/14, in G.L. account 3006-50-57-80007-720199, project number 807 0004 50 57 3006Q.
2. Elect not to award a purchase order to Miracle Recreation Equipment Company at this time and provide further direction to staff.

FISCAL IMPACT

Funding for the new play structures and playground surfacing is estimated not to exceed \$381,928.11, utilizing Quimby Development Impact Fees (2906). This item is an approved budget item for FY 13/14 in GL account 3006-50-57-80007-720199, project number 807 0004 50 57 3006Q.

This recommended action imposes NO fiscal impact to the General Fund.

CITY COUNCIL GOALS

PUBLIC FACILITIES AND CAPITAL PROJECTS:

Ensure that needed public facilities, roadway improvements, and other infrastructure improvements are constructed and maintained.

POSITIVE ENVIRONMENT:

Create a positive environment for the development of Moreno Valley’s future.

COMMUNITY IMAGE, NEIGHBORHOOD PRIDE, AND CLEANLINESS:

Promote a sense of community pride and foster an excellent image about our City by developing and executing programs which will result in quality development, enhanced neighborhood preservation efforts, including home rehabilitation and neighborhood restoration.

NOTIFICATION

Posting of the agenda.

ATTACHMENTS

- Attachment 1: Miracle Contract Agreement
- Attachment 2: HGAC Contract Information
- Attachment 3: HGAC Contract

Prepared By:
Tony Hetherman
Park Projects Coordinator

Department Head Approval:
Michael McCarty
Director of Parks and Community Services

Council Action	
Approved as requested:	Referred to:
Approved as amended:	For:
Denied:	Continued until:
Other:	Hearing set for:

This page intentionally left blank.

Attachment 1**Moreno Valley Community Services District of the City of Moreno Valley****INDEPENDENT CONTRACTOR AGREEMENT
PLAYGROUND EQUIPMENT AT EL POTRERO, FAIRWAY AND WESTBLUFF PARKS
PROJECT 12/13-80700045057**

This Agreement is made by and between the Moreno Valley Community Services District, a district formed pursuant to California Community Services District Law, County of Riverside, State of California, hereinafter referred to as the "CSD", and the following named independent contractor, hereinafter referred to as the "Contractor," based upon City policies and the following legal citations:

- A. Government Code Section 53060 authorizes the engagement of persons to perform special services as independent contractors; and
- B. The public interest, convenience, necessity and general welfare will be served by this Agreement.

This Agreement is made and entered into effective the date the CSD signs this Agreement.

1. CONTRACTOR INFORMATION:

Miracle Recreation Equipment Company
A subsidiary of PlayPower, Inc.
8445 Solution Center
Chicago, IL 60677-8004
Business Phone: 800-264-7225, Fax No. 877-215-3869
Other Contact Number: 951-695-4515
Social Security Number: N/A
Business License Number: 22609
Federal Tax I.D. Number: 43-1595099

2. CONTRACTOR SERVICES, FEES, AND RELEVANT DATES:

- A. The Contractor's scope of service is described in Attachment 'A' attached hereto and incorporated herein by this reference.
- B. The CSD's responsibility and project locations, other than payment, described in Attachment 'B' attached hereto and incorporated herein by this reference.
- C. Payment terms are provided in Attachment 'C' attached hereto and incorporated herein by this reference.
- D. Playground apparatus schematics are provided in Attachment 'D'.
- E. Contractor's quote is provided in Attachment 'E'.
- F. The Agreement shall commence on the date it is signed by the CSD. The termination date of the Agreement shall be April 30, 2014.
- G. The Contractor's Starting Date is the date listed on the issued Purchase Order, which will be utilized as the "Notice to Proceed". The Contractor agrees to diligently prosecute the contracted work, including corrective items of work, day to day thereafter, to completion within **ninety (90) working days** after said date in the "Notice to Proceed". The CSD acknowledges that it will not unreasonably withhold approval of the Contractor's requests for extensions of time in which to complete the work required. The Contractor shall not be responsible for performance delays caused by others or delays beyond the Contractor's reasonable control (excluding delays caused by non-performance or unjustified delay by Contractor, his/her/its employees, or subcontractors), and such delays shall extend the time for performance of the work by the Contractor.

H. The work performed in this contract shall be performed Monday through Friday, 7 a.m. to 4 p.m. CSD observed holidays shall be observed by the Contractor and no work shall be performed on these dates.

3. **STANDARD TERMS AND CONDITIONS:**

- A. Control of Work. Contractor is solely responsible for the content and sequence of the work, and will not be subject to control and direction as to the details and means for accomplishing the anticipated results of services. The CSD will not provide any training to Contractor or his/her/its employees.
- B. Intent of Parties. Contractor is, and at all times shall be, an independent contractor and nothing contained herein shall be construed as making the Contractor or any individual whose compensation for services is paid by the Contractor, an agent or employee of the CSD, or authorizing the Contractor to create or assume any obligation or liability for or on behalf of the CSD, or entitling the Contractor to any right, benefit, or privilege applicable to any officer or employee of the CSD.
- C. Subcontracting. Contractor may retain or subcontract for the services of other necessary contractors with the prior written approval of the CSD. Payment for such services shall be the responsibility of the Contractor. Any and all subcontractors shall be subject to the terms and conditions of this Agreement, with the exception that the CSD shall have no obligation to pay for any subcontractor services rendered. Contractor shall be responsible for paying prevailing wages where required by law [See California Labor Code Sections 1770 through 1777.7].
- D. Legal Considerations. The Contractor shall comply with applicable federal, state, and local laws in the performance of this Agreement.
- E. Contractor Indemnification. To the fullest extent permitted by law, the Contractor assumes liability for and agrees, at the Contractor's sole cost and expense, to promptly and fully indemnify, protect, hold harmless and defend (even if the allegations are false, fraudulent, or groundless), the Moreno Valley Community Services District (CSD), the City of Moreno Valley, the City Council and each member thereof, and the Moreno Valley Housing Authority and all of their respective officials, officers, directors, employees, commission members, representatives and agents ("Indemnitees"), from and against any and all claims, allegations, actions, suits, arbitrations, administrative proceedings, regulatory proceedings, or other legal proceeds, causes of action, demands, costs, judgments, liens, stop notices, penalties, liabilities, damages, losses, anticipated losses of revenues, and expenses (including, but not limited to, any fees of accountants, attorneys, experts or other professionals, or investigation expenses), or losses of any kind or nature whatsoever, whether actual, threatened or alleged, arising out of, resulting from, or in any way (either directly or indirectly), related to the Work, the Project or any breach of the Contract by Contractor or any of its officers, agents, employees, subcontractors, sub-subcontractors, or any person performing any of the Work, pursuant to a direct or indirect contract with the Contractor ("Indemnity Claims"). Such Indemnity Claims include, but are not limited to, claims for:
1. Any activity on or use of the CSD's and/or City's premises or facilities;
 2. Any liability incurred due to Contractor acting outside the scope of its authority pursuant to the Contract, whether or not caused in part by an Indemnified Party;
 3. The failure of Contractor or the Work to comply with any Applicable Law, permit or orders;
 4. Any misrepresentation, misstatement or omission with respect to any statement made in the Contract Documents or any document furnished by the Contractor in connection therewith;
 5. Any breach of any duty, obligation or requirement under the Contract Documents, including, but not limited to any breach of Contractor's warranties, representations or agreements set forth in the Contract Documents;

6. Any failure to coordinate the Work with CSD's Separate Contractors;
7. Any failure to provide notice to any party as required under the Contract Documents;
8. Any failure to act in such a manner as to protect the Project from loss, cost, expense or liability;
9. Bodily or personal injury, emotional injury, sickness or disease, or death at any time to any persons including without limitation employees of Contractor;
10. Damage or injury to real property or personal property, equipment and materials (including, but without limitation, property under the care and custody of the Contractor or the CSD) sustained by any person or persons (including, but not limited to, companies, corporations, utility company or property owner, Contractor and its employees or agents, and members of the general public);
11. Any liability imposed by Applicable Law including, but not limited to criminal or civil fines or penalties;
12. Any dangerous, hazardous, unsafe or defective condition of, in or on the Site, of any nature whatsoever, which may exist by reason of any act, omission, neglect, or any use or occupation of the Site by Contractor, its officers, agents, employees, or subcontractors;
13. Any operation conducted upon or any use or occupation of the Site by Contractor, its officers, agents, employees, or subcontractors under or pursuant to the provisions of the Contract or otherwise;
14. Any acts, errors, omission or negligence of Contractor, its officers, agents, employees, or subcontractors;
15. Infringement of any patent rights, licenses, copyrights or intellectual property which may be brought against the Contractor or Owner arising out of Contractor's Work, for which the Contractor is responsible; and
16. Any and all claims against the CSD seeking compensation for labor performed or materials used or furnished to be used in the Work or alleged to have been furnished on the Project, including all incidental or consequential damages resulting to the CSD from such claims.

Effect of Indemnitees' Active Negligence. Contractor's obligations to indemnify and hold the Indemnitees harmless **exclude** only such portion of any Indemnity Claim which is attributable to the active negligence or willful misconduct of the Indemnitee, provided such active negligence or willful misconduct is determined by agreement of the parties or by findings of a court of competent jurisdiction. In instances where an Indemnitee's active negligence accounts for only a percentage of the liability for the Indemnity Claim involved, the obligation of Contractor will be for that entire percentage of liability for the Indemnity Claim not attributable to the active negligence or willful misconduct of the Indemnitee(s). Such obligation shall not be construed to negate, abridge or otherwise reduce any other right or obligation of indemnity which would otherwise exist as to any party or person described in this Paragraph E. Subject to the limits set forth herein, the Contractor, at its own expense, shall satisfy any resulting judgment that may be rendered against any Indemnitee resulting from an Indemnity Claim. The Indemnitees shall be consulted with regard to any proposed settlement.

Independent Defense Obligation. The duty of the Contractor to indemnify and hold harmless the Indemnitees includes the separate and independent duty to defend the Indemnitees, which duty arises immediately upon receipt by Contractor of the tender of any Indemnity Claim from an Indemnitee. The Contractor's obligation to defend the Indemnitee(s) shall be at Contractor's sole expense, and not be excused because of the Contractor's inability to evaluate liability or because the Contractor evaluates liability and determines that the Contractor is not liable. This duty to defend shall apply whether or not an Indemnity Claim has merit or is meritless, or which involves claims or allegations that any or all of the Indemnitees were actively, passively, or concurrently negligent, or which otherwise asserts that the Indemnitees are responsible, in whole or in part, for any

Indemnity Claim. The Contractor shall respond within thirty (30) Calendar Days to the tender of any Indemnity Claim for defense and/or indemnity by an Indemnitee, unless the Indemnitee agrees in writing to an extension of this time. The defense provided to the Indemnitees by Contractor shall be by well qualified, adequately insured and experienced legal counsel acceptable to the CSD.

Intent of Parties Regarding Scope of Indemnity. It is the intent of the parties that the Contractor and its subcontractors of all tiers shall provide the Indemnitees with the broadest defense and indemnity permitted by Applicable Law. In the event that any of the defense, indemnity or hold harmless provisions in the Contract Documents are found to be ambiguous, or in conflict with one another, it is the parties' intent that the broadest and most expansive interpretation in favor of providing defense and/or indemnity to the Indemnitees be given effect.

Waiver of Indemnity Rights Against Indemnitees. With respect to third party claims against the Contractor, to the fullest extent permitted by law, the Contractor waives any and all rights to any type of express or implied indemnity against the Indemnitees.

Subcontractor Requirements. In addition to the requirements set forth hereinabove, Contractor shall ensure, by written subcontract agreement, that each of Contractor's subcontractors of every tier shall protect, defend, indemnify and hold harmless the Indemnitees with respect to Indemnity Claims arising out of, in connection with, or in any way related to each such subcontractors' Work on the Project in the same manner in which Contractor is required to protect, defend, indemnify and hold the Indemnitees harmless. In the event Contractor fails to obtain such defense and indemnity obligations from others as required herein, Contractor agrees to be fully responsible to the Indemnitees according to the terms of this Paragraph 11.

No Limitation or Waiver of Rights. Contractor's obligations under this Paragraph E are in addition to any other rights or remedies which the Indemnitees may have under the law or under the Contract Documents. Contractor's indemnification and defense obligations set forth in this Paragraph 11 are separate and independent from the insurance provisions set forth in the Contract Documents, and do not limit, in any way, the applicability, scope, or obligations set forth in such insurance provisions. The purchase of insurance by the Contractor with respect to the obligations required herein shall in no event be construed as fulfillment or discharge of such obligations. In any and all claims against the Indemnitees by any employee of the Contractor, any subcontractor, any supplier of the Contractor or subcontractors, anyone directly or indirectly employed by any of them, or anyone for whose acts any of them may be liable, the obligations under this Paragraph E shall not be limited in any way by any limitation on the amount or type of damages, compensation or benefits payable by or for the Contractor or any subcontractor or any supplier of either of them, under workers' or workmen's compensation acts, disability benefit acts or other employee benefit acts. Failure of the CSD to monitor compliance with these requirements imposes no additional obligations on the CSD and will in no way act as a waiver of any rights hereunder.

Withholding to Secure Obligations. In the event an Indemnity Claim arises prior to final payment to Contractor, the CSD may, in its sole discretion, reserve, retain or apply any monies due Contractor for the purpose of resolving such Indemnity Claims; provided, however, the CSD may release such funds if the Contractor provides the CSD with reasonable assurances of protection of the Indemnitees' interests. The CSD shall, in its sole discretion, determine whether such assurances are reasonable.

Survival of Indemnity Obligations. Contractor's obligations under this Paragraph E are binding on Contractor's and its subcontractors' successors, heirs and assigns and shall survive the completion of the Work or termination of the Contractor's performance of the Work.

- F. Insurance Requirements. The Contractor shall procure and maintain at its sole expense and throughout the term of this Agreement, any extension thereof, Commercial General Liability, Automobile Liability, and Workers' Compensation Insurance with such coverage limits as described herein.

Additional Insured Endorsements. The Contractor shall cause the insurance required by the Contract Document to include the Moreno Valley Community Services District (CSD), the City of Moreno Valley (City), and the Moreno Valley Housing Authority, and their respective officials, employees, commission members, officers, directors, agents, employees, volunteers and representatives as an additional insureds. For the Commercial General Liability coverage, said parties shall be named as additional insureds utilizing either:

1. Insurance Services Office (“ISO”) Additional Insured endorsement CG 20 10 (11/85); or
2. ISO Additional Insured endorsement CG 20 10 (10/01) and Additional Insured Completed Operations endorsement CG 20 37 (10/01); or
3. Substitute endorsements providing equivalent coverage, approved by the City.

The endorsements shall be signed by a person authorized by the insurer to bind coverage on its behalf. The coverage shall contain no special limitations on the scope of protection afforded to such additional insureds. Coverage for such additional insureds does not extend to liability to the extent prohibited by Insurance Code Section 11580.4.

Waivers of Subrogation. All policies of insurance required by the Contract Documents shall include or be endorsed to provide a waiver by the insurers of any rights of recovery or subrogation that the insurers may have at any time against the Moreno Valley Community Services District (CSD), the City of Moreno Valley, the City Council and each member thereof, and the Moreno Valley Housing Authority, and their respective officials, employees, commission members, officers, directors, agents, employees, volunteers and representatives.

Primary Coverage. All policies and endorsements shall stipulate that the Contractor’s (and the subcontractors’) insurance coverage shall be primary insurance as respects the Moreno Valley Community Services District (CSD), the City of Moreno Valley, the City Council and each member thereof, and the Moreno Valley Housing Authority, and their respective officials, employees, commission members, officers, directors, agents, employees, volunteers and representatives, and shall be excess of the Contractor’s (and its subcontractors’) insurance and shall not contribute with it.

Coverage Applies Separately to Each Insured and Additional Insured. Coverage shall state that the Contractor’s (and its subcontractors’) insurance shall apply separately to each insured or additional insured against whom claim is made or suit is brought, except with respect to the limits of the insurer’s liability. Coverage shall apply to any claim or suit brought by an additional insured against a named insured or other insured.

Self-Insurance. Any self-insurance (including deductibles or self-insured retention in excess of \$50,000) in lieu of liability insurance must be declared by Contractor and approved by the City in writing prior to execution of the Agreement. The City’s approval of self-insurance, if any, is within the City’s sole discretion and is subject to the following conditions:

Contractor must, at all times during the term of the Agreement and for a period of at least **one (1) year** after completion of the Project maintain and upon Owner’s reasonable request provide evidence of:

1. Contractor’s “net worth” (defined as “total assets” [defined as all items of value owned by the Contractor including tangible items such as cash, land, personal property and equipment and intangible items such as copyrights and business goodwill]) minus total outside liabilities must be reflected in a financial statement for the prior fiscal year reflecting sufficient income and budget for Contractor to afford at least one loss in an amount equal to the amount of self-insurance;
2. financial statements showing that Contractor has funds set aside/budgeted to finance the self-insured fund (i.e., Contractor has a program that fulfills functions that a primary insurer would fill;) and
3. a claims procedure that identifies how a claim is supposed to be tendered to reach the financing provided by the self-insured fund.

If at any time after such self-insurance has been approved Contractor fails to meet the financial thresholds or otherwise fails to comply with the provisions set forth in this

Paragraph G, at the option of the City:

1. the Contractor shall immediately obtain and thereafter maintain the third party insurance required under this Paragraph G and otherwise on the terms required above; or
2. the insurer shall reduce or eliminate such deductibles or self-insured retention as respects the City, the CSD, its officers, officials, employees and volunteers; or
3. the Contractor shall procure a bond guaranteeing payment of losses and related investigation, claim administration, and defense expenses.

Insurer Financial Rating. Insurance companies providing insurance hereunder shall be rated A-:VII or better in Best's Insurance Rating Guide and shall be legally licensed and qualified to conduct insurance business in the State of California.

Notices to CSD of Cancellation or Changes. Each insurance policy described in Paragraph G shall contain a provision or be endorsed to state that coverage will not be cancelled without **thirty (30) days'** prior written notice by certified or registered mail to the CSD (this obligation may be satisfied in the alternative by requiring such notice to be provided by Contractor's insurance broker and set forth on its Certificate of Insurance provided to the CSD), except that cancellation for non-payment of premium shall require ten (10) days prior written notice by certified or registered mail. If an insurance carrier cancels any policy or elects not to renew any policy required to be maintained by Contractor pursuant to the Contract Documents, Contractor agrees to give written notice to the CSD at the address indicated on the first page of the Agreement. Contractor agrees to provide the same notice of cancellation and non-renewal to the CSD that is required by such policy(ies) to be provided to the First Named Insured under such policy(ies). Contractor shall provide confirmation that the required policies have been renewed not less than seven (7) days prior to the expiration of existing coverages and shall deliver renewal or replacement policies, certificates and endorsements to the City Clerk within fourteen (14) days of the expiration of existing coverages. Contractor agrees that upon receipt of any notice of cancellation or alteration of the policies, Contractor shall procure within five (5) days, other policies of insurance similar in all respects to the policy or policies to be cancelled or altered. Contractor shall furnish to the City Clerk copies of any endorsements that are subsequently issued amending coverage or limits within fourteen (14) days of the amendment.

Commercial General Liability. Coverage shall be written on an ISO Commercial General Liability "occurrence" form CG 00 01 (10/01 or later edition) or equivalent form approved by the City for coverage on an occurrence basis. The insurance shall cover liability, including, but not limited to, that arising from premises operations, stop gap liability, independent contractors, products-completed operations, personal injury, advertising injury, and liability assumed under an insured contract. The policy shall be endorsed to provide the Aggregate Per Project Endorsement ISO form CG 25 03 (11/85). Coverage shall contain no contractors' limitation or other endorsement limiting the scope of coverage for liability arising from pollution, explosion, collapse, or underground (x, c, u) property damage. Contractor shall provide Products/Completed Operations coverage to be maintained continuously for a minimum of **one (1) year** after Final Acceptance of the Work, and any extension of the one-year correction guarantee period in accordance with Section 6-8.1 of the CSD Special Provisions.

Contractor shall maintain Commercial General Liability insurance with the following minimum limits: \$1,000,000 per occurrence / \$2,000,000 aggregate / \$2,000,000 products-completed operations.

Business Automobile Liability. Coverage shall be written on ISO form CA 00 01 (12/93 or later edition) or a substitute form providing equivalent coverage for owned, hired, leased and non-owned vehicles, whether scheduled or not, with \$1,000,000 combined single limit per accident for bodily injury and property damage. If necessary, the policy shall be endorsed to provide contractual liability coverage.

Workers' Compensation. Contractor shall comply with the applicable sections of the California Labor Code concerning workers' compensation for injuries on the job.

Compliance is accomplished in one of the following manners:

1. Provide copy of permissive self-insurance certificate approved by the State of California; or
2. Secure and maintain in force a policy of workers' compensation insurance with statutory limits and Employer's Liability Insurance with a minimal limit of **\$1,000,000** per accident; or
3. Provide a "waiver" form certifying that no employees subject to the Labor Code's Workers' Compensation provision will be used in performance of this Contract.

Subcontractors' Insurance. The Contractor shall include all subcontractors as insureds under its policies or shall furnish separate certificates and endorsements for each subcontractor. All coverages for subcontractors shall be subject to all of the requirements stated herein.

G. Intellectual Property. Any system or documents developed, produced or provided under this Agreement, including any intellectual property discovered or developed by Contractor in the course of performing or otherwise as a result of its work, shall become the sole property of the CSD unless explicitly stated otherwise in this Agreement. The Contractor may retain copies of any and all material, including drawings, documents, and specifications, produced by the Contractor in performance of this Agreement. The CSD and the Contractor agree that to the extent permitted by law, until final approval by the CSD, all data shall be treated as confidential and will not be released to third parties without the prior written consent of both parties.

H. Entire Agreement. This Agreement constitutes the entire agreement between the parties. There are no understandings, agreements, or representations of warranties, expressed or implied, not specified in this Agreement. This Agreement applies only to the current proposal as attached. This Agreement may be modified or amended only by a subsequent written Agreement signed by both parties. Assignment of this Agreement is prohibited without prior written consent.

(a) The CSD may terminate this Agreement without cause by giving at least ten (10) days written notice to the Contractor. The written notice shall specify the date of termination. Upon receipt of such notice, the Contractor may continue work through the date of termination, provided that no work or service(s) shall be commenced or continued after receipt of the notice which is not intended to protect the interest of the CSD. The CSD shall pay the Contractor within thirty (30) days after receiving any invoice after the date of termination for all non-objected to services performed by the Contractor in accordance herewith through the date of termination.

(b) Either party may terminate this Agreement for cause. In the event the CSD terminates this Agreement for cause, the Contractor shall perform no further work or service(s) under the Agreement unless the notice of termination authorizes such further work.

Payment. Payments to the Contractor pursuant to this Agreement will be reported to federal and state taxing authorities as required. The CSD will not withhold any sums from compensation payable to Contractor. Contractor is independently responsible for the payment of all applicable taxes. Where the payment terms provide for compensation on a time and materials basis, the Contractor shall maintain adequate records to permit inspection and audit of the Contractor's time and materials charges under the Agreement. Upon reasonable notice, such records must be made available to the CSD's agent; however, nothing herein shall convert such records into public records. Such records shall be retained by the Contractor for three (3) years following completion of the services under the Agreement. No payment shall be made until the product has been fully installed, inspected and certified by an authorized Certified Playground Safety Inspector (CPSI).

I. Stop Notice Withholds. The CSD may withhold payments to cover claims filed under Civil Code § 3179 et seq.

J. Restrictions on CSD/City Employees. The Contractor shall not employ any CSD or City employee or official in the work performed pursuant to this Agreement. No officer or

employee of the CSD or City shall have any financial interest in this Agreement in violation of federal, state, or local law.

- K. Choice of Law and Venue. The laws of the State of California shall govern the rights, obligations, duties, and liabilities of the parties to this Agreement, and shall govern the interpretation of this Agreement. Any legal proceeding arising from this Agreement shall be brought in the appropriate court located in Riverside County, State of California.
- L. Legal Action. Should either party bring any legal or equitable action for the purpose of protecting or enforcing its rights under this Contract Agreement, the prevailing party in such action shall recover in addition to all other relief, its reasonable attorney fees and court costs to be fixed by the court.
In addition to the foregoing award of attorney fees, the prevailing party shall be entitled to its attorneys' fees incurred in any post judgement proceedings to enforce any judgments in connection with this Contract Agreement. The Provision is separate and several and shall survive the merge of this Provision into any judgement.
- M. Warranty. The Contractor, the Contractor's heirs, executors, administrators, successors, or assigns guarantee that all work performed under this Contract fully meets the requirements thereof as to quality of workmanship and materials furnished. If any defects in materials or workmanship become evident within a period of one year from the date of the acceptance of the work by the City Council, the Contractor shall, at his or her own expense, make any repair(s) or replacement(s) necessary to restore the work to full compliance with the Plans and Specifications.
- N. Prevailing Wage. The Contractor and any agents or subcontractors of the Contractor shall pay the prevailing rates of per diem wages established by the California Department of Industrial Relations and Prevailing Wage Rates. The Contractor and any agents or subcontractors of the Contractor shall also adhere to the California Labor Code, Division 2, Part 7, "Public Works and Public Agencies," and the California Administrative Code, Title 8, Group 3, "Payment of Prevailing Wages upon Public Works," all of which are made a part of the Contract documents. The Contractor shall submit a list of all trades utilized in the project and corresponding DIR wage determinations. Certified payroll reports, Certificates of Compliance and Fringe Benefit Statements shall be submitted weekly.
- O. Records. The Contractor agrees that he or she and its subcontractors shall maintain and keep books, payrolls, invoices of materials, records on a current basis, and recording all transactions pertaining to this Agreement in a form in accordance with generally acceptable accounting principles. Said books and records shall be made available to the City of Moreno Valley, Riverside County, the State of California, the Federal Government and to any authorized representative thereof for purposes of audit and inspection at all reasonable times and places. All such books, payrolls, invoices of materials, and records shall be retained for such periods of time as required by law, provided, however, notwithstanding any shorter period of retention, all books, records, and supporting detail shall be retained for a period of at least three years after Final Acceptance.
- P. Performance. The parties do for themselves, their heirs, executors, administrators, successors and assigns agree to the full performance of all of the provisions herein contained. The Contractor may not, either voluntarily or by action of law, assign any obligation assumed by the Contractor hereunder without prior written consent of the CSD.
- Q. Workers' Compensation. By my signature hereunder, as Contractor, I certify that I am aware of the Provisions of Section 3700, of the Labor Code which require every employer to be insured against liability for Workers' Compensation or to undertake self-insurance in accordance with the Provisions of that code, and I will comply with such Provisions before commencing the performance of the work of this Contract.
- R. Contract Commencement. The effective date of this Contract Agreement shall be the date of the Award of Contract by the CSD.
- S. Licensing. Contractors are required by law to be licensed and regulated by the Contractors' State License Board. Any questions concerning a Contractor may be referred to the

Registrar, Contractors' State License Board, 3132 Bradshaw Road, Sacramento, CA 95826. Mailing address: P.O.Box 26000, Sacramento, CA 95826.

- T. City of Moreno Valley Business License. The Contractor and all subcontractors shall obtain and keep current a City of Moreno Valley Business License prior to commencement and throughout the duration of the Work.
- U. Successors and Assigns. The parties bind themselves, their heirs, executors, administrators, successors and assigns the covenants, agreements and obligations contained in the Contract Documents. The Contractor shall not, either voluntarily or by action of law, assign any right or obligation of the Contractor under the Contract Documents without prior written consent of the CSD.
- V. Unconditional Release of Materials and Labor. Prior to final payment for material and labor, the Contractor shall provide the CSD Unconditional Wavers of Release for all products and associated labor.
- W. Certification. Prior to final payment, the Contractor shall provide a Certification of Compliance letter, from a Certified Playground Inspector (CPSI), stating that all playground materials were installed in compliance with the United States Consumer Product Safety Commission (CPSC) guidelines.
- X. Bonds.

Performance Bond. The Contractor shall furnish a satisfactory Performance Bond meeting all statutory requirements of the State of California on the form provided by the CSD. The bond shall be furnished as a guarantee of the faithful performance of the requirements of the Contact Documents as may be amended from time to time, including, but not limited to, liability for delays and damages (both direct and consequential) to the CSD and the CSD's Separate Contractors and consultants, warranties, guarantees, and indemnity obligations, in an amount that shall remain equal to one hundred percent (100%) of the Contract Price.

Labor and Materials Payment Bond. The Contractor shall furnish a satisfactory Labor and Materials Payment Bond meeting all statutory requirements of the State of California on the form provided by the CSD in an amount that shall remain equal to one hundred percent (100%) of the Contract Price to secure payment of all claims, demands, stop notices, or charges of the State of California, of material suppliers, mechanics, or laborers employed by the Contractor or by any Subcontractor, or any person, form, or entity eligible to file a stop notice with respect to the Work.

All bonds shall be executed by a California-admitted surety insurer. Bonds issued by a California-admitted surety insurer listed on the latest version of the U.S Department of Treasury Circular 570 shall be deemed accepted unless specifically rejected by the CSD. Bonds issued by sureties not listed in Treasury Circular 570 must be accompanied by all documents enumerated in California Code of Civil Procedure Section 995.660(a). The bonds shall bear the same date as the Contract. The attorney-in-fact who executes the required bonds on behalf of the surety shall affix thereto a certified and current copy of the power of attorney. In the event of changes that increase the Contract Price, the amount of each bond shall be deemed to increase and at all times remain equal to the Contract Price. The signatures shall be acknowledged by a notary public. Every bond must display the surety's bond number and incorporate the Contract for construction of the Work by reference. The terms of the bonds shall provide that the surety agrees that no change, extension of time, alteration, or modification of the Contract Documents or the Work to be performed thereunder shall in any way affect its obligations and shall waive notice of any such change, extension of time, alteration, or modification of the Contract Documents. The surety further agrees that it is obligated under the bonds to any successor, grantee, or assignee of the CSD.

Upon the request of any person or entity appearing to be a potential beneficiary of bonds covering payment of obligations arising under the Contract, the Contractor shall promptly furnish a copy of the bonds or shall authorize a copy to be furnished.

Should any bond become insufficient, or should any of the sureties, in the opinion of the CSD, become non-responsible or unacceptable, the Contractor shall, within ten (10)

Calendar Days after receiving notice from the CSD, provide written documentation to the Satisfaction of the CSD that Contractor has secured new or additional sureties for the bonds; otherwise the Contractor shall be in default of the Contract. No further payments shall be deemed due or will be made under Contract until a new surety(ies) qualifies and is accepted by the CSD.

Contractor agrees that the Labor and Materials Payment Bond and Faithful Performance Bond attached to this Agreement are for reference purposes only, and shall not be considered a part of this Agreement. Contractor further agrees that said bonds are separate obligations of the Contractor and its surety, and that any attorney's fee provision contained in any payment bond or performance bond shall not apply to this Agreement. In the event there is any litigation between the parties arising from the breach of this Agreement, each party will bear its own attorneys' fees in the litigation.

**INDEPENDENT CONTRACTOR AGREEMENT
PLAYGROUND EQUIPMENT AT EL POTRERO, FAIRWAY & WESTBLUFF PARKS
PROJECT 12/13-80700045057**

SIGNATURE PAGE TO FOLLOW

Moreno Valley Community Services District

Miracle Recreation Equipment Company

BY: _____
President of the Board of Directors

DATE: _____

License No./
Classification: _____

Expiration Date: _____

Federal I.D. No.: _____

<u>INTERNAL USE ONLY</u>
ATTEST: _____ City Clerk <i>(only needed if Mayor signs)</i>
APPROVED AS TO LEGAL FORM: _____ City Attorney _____ Date
RECOMMENDED FOR APPROVAL: _____ Parks and Community Services Director <i>(if contract exceeds \$15,000)</i> _____ Date

PRINT NAME: _____

SIGNATURE: _____

TITLE: _____

DATE: _____

PRINT NAME: _____

SIGNATURE: _____

TITLE: _____

DATE: _____

SIGNING INSTRUCTIONS TO THE CONTRACTOR:

Signature(s) must be accompanied by a completed notary certificate of acknowledgement attached hereto. A general partner must sign on behalf of a partnership. **Two (2)** corporate officers must sign on behalf of a corporation unless the corporation has a corporate resolution that allows one person to sign on behalf of the corporation; if applicable, said resolution must be attached hereto. The corporate seal may be affixed hereto.

CALIFORNIA ALL-PURPOSE CERTIFICATE OF ACKNOWLEDGMENT

State of California

County of _____

On _____ before me, _____,
(Here insert name and title of the officer)

personally appeared _____,

who proved to me on the basis of satisfactory evidence to be the person(s) whose name(s) is/are subscribed to the within instrument and acknowledgement to me that he/she they executed the same in his/her/their authorized capacity(ies), and that by his/her/their signature(s) on the instrument the person(s), or the entity upon behalf of which the person(s) acted, executed the instrument.

I certify under PENALTY OF PERJURY under the laws of the State of California that the foregoing paragraph is true and correct.

WITNESS my hand and official seal.

Signature of Notary Public

(Notary Seal)

ADDITIONAL OPTIONAL INFORMATION

INSTRUCTIONS FOR COMPLETING THIS FORM

Any acknowledgment completed in California must contain verbiage exactly appears above in the notary section or a separate acknowledgment form must properly completed and attached to that document. The only exception is if a document is recorded outside of California. In such instances, any alternative acknowledgment verbiage as may be printed on such a document so long as the verbiage does not require the notary to do something that is illegal for a notary in California (i.e. certifying the authorized capacity of the signer). Please check the document carefully for proper notarial wording and attach this form if required.

- State and County information must be the State and County where the document signer(s) personally appeared before the notary public for acknowledgment.
- Date of notarization must be the date that the signer(s) personally appeared which must also be the same date the acknowledgment is completed.
- The notary public must print his or her name as it appears within his or her commission followed by a comma and then your title (notary public).
- Print the name(s) of document signer(s) who personally appear at the time of notarization.
- Indicate the correct singular or plural forms by crossing off incorrect forms (i.e. ~~he~~/she/~~they~~, is/~~are~~) or circling the correct forms. Failure to correctly indicate this information may lead to rejection of document recording.
- The notary seal impression must be clear and photographically reproducible. Impression must not cover text or lines. If seal impression smudges, re-seal if a sufficient area permits, otherwise complete a different acknowledgment form.
- Signature of the notary public must match the signature on file with the office of the county clerk.
- Additional information is not required but could help to ensure this acknowledgment is not misused or attached to a different document.
- Indicate title or type of attached document, number of pages and date.
- Indicate the capacity claimed by the signer. If the claimed capacity is a corporate officer, indicate the title (i.e. CEO, CFO, Secretary).
- Securely attach this document to the signed document

DESCRIPTION OF THE ATTACHED DOCUMENT

AGREEMENT PROJECT #12/13-807-0004-50-57

(Title or description of attached document)

(Title or description of attached document continued)

Number of Pages _____

Document Date _____

Additional Information

CAPACITY CLAIMED BY THE SIGNER

- Individual(s)
- Corporate Officer

(Title)

- Partner (s)
- Attorney-in-Fact
- Other _____

BOND NO. _____

**LABOR AND MATERIALS PAYMENT BOND
(100% of Total Contract Amount)**

**Moreno Valley Community Services District of the City of Moreno Valley
PLAYGROUND EQUIPMENT AT EL POTRERO, FAIRWAY & WESTBLUFF PARKS
PROJECT 12/13-80700045057**

KNOW ALL MEN AND WOMEN BY THESE PRESENTS

THAT WHEREAS, the Moreno Valley Community Services District of the City of Moreno Valley, County of Riverside, State of California, known as "CSD," has awarded to Miracle Recreation Equipment Company as Principal hereinafter designated as "Contractor" and have entered into an Agreement whereby the Contractor agrees to construct or install and complete certain designated public improvements, which said Agreement, effective on the date signed by the President of the Board of Directors, and identified as Project No. 12/13-80700045057, and all Contract Documents are hereby referred to and made a part hereof; and

WHEREAS, said Contractor under the terms of said Contract Documents is required to furnish a bond to secure the payment of claims of laborers, mechanics, materialmen, and other persons, as provided by law;

NOW THEREFORE, we the undersigned Contractor and _____, as Surety, are held and firmly bound unto the Moreno Valley Community Services District of the City of Moreno Valley, County of Riverside in the penal sum of three-hundred fifty-six thousand nine-hundred twenty-eight and 11/100 dollars, (\$ 356,928.11), lawful money of the United States, to be paid to the said CSD or its certain attorney, its successors and assigns; for which payment, well and truly to be made, we bind ourselves, our heirs, executors and administrators, successors and assigns, jointly and severally liable (CCP 995.320 (a)(1)), firmly by these presents.

THE CONDITION OF THIS OBLIGATION IS SUCH, that if said Contractor, his or her or its heirs, executors, administrator, successors or assigns, or subcontractors, shall fail to pay any of the persons described in the State of California Civil Code, Section 3181, or amounts due under the Unemployment Insurance Code with respect to work or labor performed by any such claimant, or any amounts required to be deducted, withheld, and paid over to the Franchise Tax Board from the wages of employees of the Contractor and his or her subcontractors, pursuant to Section 13020, of the Unemployment Insurance Code, with respect to such work and labor, that the Surety or Sureties herein will pay for the same in an amount not exceeding the sum specified in this bond, otherwise the above obligation shall be void. In the event suit is brought upon this bond by the CSD or other person entitled to bring such an action and judgement is recovered, the Surety shall pay all costs incurred by the CSD in such suit, including a reasonable attorney fee to be fixed by the court.

This bond shall inure to the benefit of any of the persons described in the State of California Civil Code Section 3181, to give a right of action to such persons or their assigns in any suit brought upon this bond.

(SIGNATURE PAGE FOLLOWS)

Faithful Performance Bond

IN WITNESS WHEREOF, we have hereunto set our hands, and seals on this _____ day of _____ 20____.

CONTRACTOR (Principal)

SURETY

Contractor Name: _____

Name: _____

Address: _____

Address: _____

Telephone No.: _____

Telephone No.: _____

Print Name: _____

Print Name: _____

Attorney-in-Fact

Signature: _____

Signature: _____

Approved as to Form this

_____ day of _____ 20____

City Attorney
City of Moreno Valley

NOTE:

- The bond shall be executed by a California admitted surety insurer (CCP 995.311).
- The bond shall include an attached Notary Certificate for the Attorney-in-Fact.
- The bond shall include an attached Notary Certificate for the Bidder.
- The bond shall include an attached original Power of Attorney only authorizing the Attorney-in-Fact to act for the Surety.
- The bond shall include the address at which the Principal (Bidder) and Surety may be served with notices, papers and other documents.
- The Bidder's and Surety's corporate seal may be affixed hereto.

Faithful Performance Bond

- CALIFORNIA ALL-PURPOSE CERTIFICATE OF ACKNOWLEDGMENT

State of California

County of _____

On _____ before me, _____,
(Here insert name and title of the officer)

personally appeared _____,

who proved to me on the basis of satisfactory evidence to be the person(s) whose name(s) is/are subscribed to the within instrument and acknowledgement to me that he/she they exceeded the same in his/her/their authorized capacity(ies), and that by his/her/their signature(s) on the instrument the person(s), or the entity upon behalf of which the person(s) acted, executed the instrument.

I certify under PENALTY OF PERJURY under the laws of the State of California that the foregoing paragraph is true and correct.

WITNESS my hand and official seal.

Signature of Notary Public

(Notary Seal)

ADDITIONAL OPTIONAL INFORMATION INSTRUCTIONS FOR COMPLETING THIS FORM

Any acknowledgment completed in California must contain verbiage exactly as appears above in the notary section or a separate acknowledgment form must be properly completed and attached to that document. The only exception is if a document is recorded outside of California. In such instances, any alternative acknowledgment verbiage as may be printed on such a document so long as the verbiage does not require the notary to do something that is illegal for a notary in California (i.e. certifying the authorized capacity of the signer). Please check the document carefully for proper notarial wording and attach this form if required.

DESCRIPTION OF THE ATTACHED DOCUMENT

LABOR AND MATERIALS PAYMENT BOND
SIGNATURE PAGE

(Title or description of attached document)

(Title or description of attached document continued)

Number of Pages _____

Document Date _____

Additional Information

- State and County information must be the State and County where the document signer(s) personally appeared before the notary public for acknowledgment.
- Date of notarization must be the date that the signer(s) personally appeared which must also be the same date the acknowledgment is completed.
- The notary public must print his or her name as it appears within his or her commission followed by a comma and then your title (notary public).
- Print the name(s) of document signer(s) who personally appear at the time of notarization.
- Indicate the correct singular or plural forms by crossing off incorrect forms (i.e. ~~he~~/she/~~they~~, is/~~are~~) or circling the correct forms. Failure to correctly indicate this information may lead to rejection of document recording.
- The notary seal impression must be clear and photographically reproducible. Impression must not cover text or lines. If seal impression smudges, re-seal if a sufficient area permits, otherwise complete a different acknowledgment form.
- Signature of the notary public must match the signature on file with the office of the county clerk.
 - ❖ Additional information is not required but could help to ensure this acknowledgment is not misused or attached to a different document.
 - ❖ Indicate title or type of attached document, number of pages and date.
 - ❖ Indicate the capacity claimed by the signer. If the claimed capacity is a corporate officer, indicate the title (i.e. CEO, CFO, Secretary).
- Securely attach this document to the signed document.

CAPACITY CLAIMED BY THE SIGNER

- Individual(s)
- Corporate Officer

(Title)

- Partner (s)
- Attorney-in-Fact
- Other _____

BOND NO. _____

**FAITHFUL PERFORMANCE BOND
(100% of Total Contract Price)**

**Moreno Valley Community Services District of the City of Moreno Valley
PLAYGROUND EQUIPMENT AT EL POTRERO, FAIRWAY & WESTBLUFF PARKS
PROJECT 12/13-80700045057**

KNOW ALL MEN AND WOMEN BY THESE PRESENTS:

THAT WHEREAS, the Moreno Valley Community Services District of the City of Moreno Valley, County of Riverside, State of California, known as "CSD," has awarded to Miracle Recreation Equipment Company as Principal hereinafter designated as "Contractor" and have entered into an Agreement whereby the Contractor agrees to construct or install and complete certain designated public improvements, which said Agreement, effective on the date signed by the President of the Board of Directors, and identified as Project No. 12/13-80700045057, and all Contract Documents are hereby referred to and made a part hereof; and

WHEREAS, said Contractor under the terms of said Contract Documents is required to furnish a bond guaranteeing the faithful performance of said Agreement;

NOW THEREFORE, we the undersigned Contractor and _____, as Surety, are held and firmly bound unto the Moreno Valley Community Services District of the City of Moreno Valley, County of Riverside in the penal sum of three-hundred fifty-six thousand nine-hundred twenty-eight and 11/100 dollars, (\$ 356,928.11), lawful money of the United States, to be paid to the said CSD or its certain attorney, its successors and assigns; for which payment, well and truly to be made, we bind ourselves, our heirs, executors and administrators, successors and assigns, jointly and severally liable (CCP 995.320 (a)(1)), firmly by these presents.

THE CONDITION OF THIS OBLIGATION IS SUCH, that if the above bound Contractor, his or her or its heirs, executors, administrators, successors or assigns, shall in all things stand to and abide by, and well and truly keep and perform the covenants, conditions and provisions in said Contract Documents and any alterations thereof made as therein provided, on his or her or their part, to be kept and performed at the time and in the manner therein specified, and in all respects according to their true intent and meaning, and shall indemnify and save harmless the CSD, its officers, agents and employees, as therein stipulated, then this obligation shall become null and void; otherwise it shall be and remain in full force and effect. In the event suit is brought upon this bond by the CSD and judgement is recovered, the Surety shall pay all costs incurred by the CSD in such suit, including a reasonable attorney fee to be fixed by the court.

The Surety hereby stipulates and agrees that no change, extension of time, alteration, or addition to the terms of the Contract Documents or to the Work to be performed thereunder, or the Provisions accompanying the same shall in any way affect its obligations on this bond, and it does hereby waive notice of any such change, extension of time, alteration or addition to the terms of the Contract Documents or to the Work or the Provisions.

(SIGNATURE PAGE FOLLOWS)

BOND NO. _____

IN WITNESS WHEREOF, we have hereunto set our hands, and seals on this _____ day of _____ 20____.

CONTRACTOR (Principal)

SURETY

Contractor Name: _____

Name: _____

Address: _____

Address: _____

Telephone No.: _____

Telephone No.: _____

Print Name: _____

Print Name: _____

Attorney-in-Fact

Signature: _____

Signature: _____

Approved as to Form this

_____ day of _____ 20____

City Attorney
City of Moreno Valley

NOTE:

- The bond shall be executed by a California admitted surety insurer (CCP 995.311).
- The bond shall include an attached Notary Certificate for the Attorney-in-Fact.
- The bond shall include an attached Notary Certificate for the Bidder.
- The bond shall include an attached original Power of Attorney only authorizing the Attorney-in-Fact to act for the Surety.
- The bond shall include the address at which the Principal (Bidder) and Surety may be served with notices, papers and other documents.
- The Bidder's and Surety's corporate seal may be affixed hereto.

- CALIFORNIA ALL-PURPOSE CERTIFICATE OF ACKNOWLEDGMENT

State of California

County of _____

On _____ before me, _____,
(Here insert name and title of the officer)

personally appeared _____,

who proved to me on the basis of satisfactory evidence to be the person(s) whose name(s) is/are subscribed to the within instrument and acknowledgement to me that he/she they exceeded the same in his/her/their authorized capacity(ies), and that by his/her/their signature(s) on the instrument the person(s), or the entity upon behalf of which the person(s) acted, executed the instrument.

I certify under PENALTY OF PERJURY under the laws of the State of California that the foregoing paragraph is true and correct.

WITNESS my hand and official seal.

Signature of Notary Public

(Notary Seal)

ADDITIONAL OPTIONAL INFORMATION

INSTRUCTIONS FOR COMPLETING THIS FORM

Any acknowledgment completed in California must contain verbiage exactly as appears above in the notary section or a separate acknowledgment form must be properly completed and attached to that document. The only exception is if a document is recorded outside of California. In such instances, any alternative acknowledgment verbiage as may be printed on such a document so long as the verbiage does not require the notary to do something that is illegal for a notary in California (i.e. certifying the authorized capacity of the signer). Please check the document carefully for proper notarial wording and attach this form if required.

DESCRIPTION OF THE ATTACHED DOCUMENT

FAITHFUL PERFORMANCE BOND
SIGNATURE PAGE

(Title or description of attached document)

(Title or description of attached document continued)

Number of Pages _____

Document Date _____

Additional Information

- State and County information must be the State and County where the document signer(s) personally appeared before the notary public for acknowledgment.
- Date of notarization must be the date that the signer(s) personally appeared which must also be the same date the acknowledgment is completed.
- The notary public must print his or her name as it appears within his or her commission followed by a comma and then your title (notary public).
- Print the name(s) of document signer(s) who personally appear at the time of notarization.
- Indicate the correct singular or plural forms by crossing off incorrect forms (i.e. ~~he~~/she/~~they~~, is/~~are~~) or circling the correct forms. Failure to correctly indicate this information may lead to rejection of document recording.
- The notary seal impression must be clear and photographically reproducible. Impression must not cover text or lines. If seal impression smudges, re-seal if a sufficient area permits, otherwise complete a different acknowledgment form.
- Signature of the notary public must match the signature on file with the office of the county clerk.
 - ❖ Additional information is not required but could help to ensure this acknowledgment is not misused or attached to a different document.
 - ❖ Indicate title or type of attached document, number of pages and date.
 - ❖ Indicate the capacity claimed by the signer. If the claimed capacity is a corporate officer, indicate the title (i.e. CEO, CFO, Secretary).
- Securely attach this document to the signed document.

CAPACITY CLAIMED BY THE SIGNER

- Individual(s)
- Corporate Officer

(Title)

- Partner (s)
- Attorney-in-Fact
- Other _____

ATTACHMENT 'A'

SCOPE OF WORKFairway Park:

1. This is a State of California Prevailing Wage Project; certified payroll is required per the Department of Industrial Relations guidelines.
2. Provide and maintain temporary fence (approx.190 l.f.) around area of work (no barb wire allowed).
3. Demo and dispose of all existing play equipment, footings, ramps, rubber surfacing and its base concrete, sand, soil, engineered wood fiber, or other base material. Excavate play pit materials to a depth minimum of 14”.
4. Contractor to provide the CSD a **weight certification and weight in ‘Tons’** for all recyclable material (concrete, steel, rubber, etc.) removed from the project. The certification shall be generated from the disposal or recycler facility. The Contractor shall be careful not to contaminate materials with other foreign matter.
5. Install one (1) concrete ADA ramp with a maximum 4.5% slope (direction of travel) and a 1.5% maximum cross slope. The ramp must extend to the bottom of the play pit and have a minimum 6” high protective edge. All ramps shall be compliant with ADA/Title 24 and have 6’ landings. Ramps shall be reinforced with #4 rebar @ 24” on center. Minimum thickness of concrete shall be no less than 6”. Base material for ramp must be Class-II, compacted to 95%.
6. Install two (2) large sump drains (36” wide x 72” deep), utilizing drainage fabric and ¾” washed gravel and filter fabric. The grade shall slope approximately 2% toward the sumps.
7. Install Kid’s Choice modular play structure with one (1) Integral 18’ x 18’ Playcover and Nexus play equipment.
8. Install a minimum of 1760 square feet of Fibar System 312 (including filter cloth and drainage channels) to a minimum compacted depth of 12”. Contractor shall make allowances for the extra depth created by the drainage slope. The finished surface of Fibar shall be level across the perimeter of the play pit. Compaction shall be using water and a power whacker or equal.
9. Replace/repair turf, plant and or hardscape damage caused by construction vehicles and/or equipment.
10. Contractor to supply product submittals and shop drawings. Concrete shall be Greenbook 560C-3250 PSI for footings and Greenbook 560C-3250 PSI for flatwork. Fly ash will not be permitted on any concrete. Contractor shall compact all footing excavations and flatwork sub base to 90%.
11. Contractor shall notify Underground Service Alert, prior to any excavation.
12. Contractor to provide unconditional releases from all material suppliers and subcontractors.

El Potrero Park:

1. This is a State of California Prevailing Wage Project; certified payroll is required per the Department of Industrial Relations guidelines.
2. Provide and maintain temporary fence (approx. 240 l.f.) around area of work (no barb wire allowed).
3. Demo and dispose of all existing play equipment, footings, ramps, rubber surfacing and its base concrete, sand, soil, engineered wood fiber, or other base material. Excavate play pit materials to a depth minimum of 14”.
4. Contractor to provide the CSD a **weight certification and weight in ‘Tons’** for all recyclable material (concrete, steel, rubber, etc.) removed from the project. The certification shall be generated from the disposal or recycler facility. The Contractor shall be careful not to contaminate materials with other foreign matter.
5. Install one (1) concrete ADA ramp with a maximum 4.5% slope (direction of travel) and a 1.5% maximum cross slope. The ramp must extend to the bottom of the play pit and have a minimum 6” high protective edge. All ramps shall be compliant with ADA/Title 24 and have 6’ landings. Ramps shall be reinforced with #4 rebar @ 24” on center. Minimum thickness of concrete shall be no less than 6”. Base material for ramp must be Class-II, compacted to 95%.
6. Install two (2) large sump drains (36” wide x 72” deep), utilizing drainage fabric and ¾” washed gravel and filter fabric. The grade shall slope approximately 2% toward the sumps.
7. Install Kid’s Choice modular play structure and UPC Rocks and ropes course.
8. Install a minimum of 2003 square feet of Fibar System 312 (including filter cloth and drainage channels) to a minimum compacted depth of 12”. Contractor shall make allowances for the extra depth created by the drainage slope. The finished surface of Fibar shall be level across the perimeter of the play pit. Compaction shall be using water and a power whacker or equal.
9. Replace/repair turf, plant and or hardscape damage caused by construction vehicles and/or equipment.
10. Contractor to supply product submittals and shop drawings. Concrete shall be Greenbook 560C-3250 PSI for footings and Greenbook 560C-3250 PSI for flatwork. Fly ash will not be permitted on any concrete. Contractor shall compact all footing excavations and flatwork sub base to 90%.
11. Contractor shall notify Underground Service Alert, prior to any excavation.
12. Contractor to provide unconditional releases from all material suppliers and subcontractors.

Westbluff Park:

1. This is a State of California Prevailing Wage Project; certified payroll is required per the Department of Industrial Relations guidelines.
2. Provide and maintain temporary fence (approx. 360 l.f.) around area of work (no barb wire allowed).
3. Demo and dispose of all existing play equipment, footings, ramps, rubber surfacing and its base concrete, sand, soil, engineered wood fiber, or other base material. Excavate play pit materials to a depth minimum of 14”.
4. Contractor to provide the CSD a **weight certification and weight in ‘Tons’** for all recyclable material (concrete, steel, rubber, etc.) removed from the project. The certification shall be generated from the disposal or recycler facility. The Contractor shall be careful not to contaminate materials with other foreign matter.
5. Install one (1) concrete ADA ramp with a maximum 4.5% slope (direction of travel) and a 1.5% maximum cross slope. The ramp must extend to the bottom of the play pit and have a minimum 6” high protective edge. All ramps shall be compliant with ADA/Title 24 and have 6’ landings. Ramps shall be reinforced with #4 rebar @ 24” on center. Minimum thickness of concrete shall be no less than 6”. Base material for ramp must be Class-II, compacted to 95%.
6. Install two (2) large sump drains (36” wide x 72” deep), utilizing drainage fabric and ¾” washed gravel and filter fabric. The grade shall slope approximately 2% toward the sumps.
7. Install Kid’s Choice Mega Tower play structure, saddle seats, two (2) bay swing and 2-5 play structure with one (1) 18’ x 18’ Playcover.
8. Install a minimum of 4890 square feet of Fibar System 312 (including filter cloth and drainage channels) to a minimum compacted depth of 12”. Contractor shall make allowances for the extra depth created by the drainage slope. The finished surface of Fibar shall be level across the perimeter of the play pit. Compaction shall be using water and a power whacker or equal.
9. Replace/repair turf, plant and or hardscape damage caused by construction vehicles and/or equipment.
10. Contractor to supply product submittals and shop drawings. Concrete shall be Greenbook 560C-3250 PSI for footings and Greenbook 560C-3250 PSI for flatwork. Fly ash will not be permitted on any concrete. Contractor shall compact all footing excavations and flatwork sub base to 90%.
11. Contractor shall notify Underground Service Alert, prior to any excavation.
12. Contractor to provide unconditional releases from all material suppliers and subcontractors.

ATTACHMENT 'B'

CSD'S RESPONSIBILITY AND PROJECT LOCATIONS

- Provide Contractor access and water to the site.
- Ensure irrigation water is off as necessary for the Contractor to perform their duties. The Contractor shall notify the Park Maintenance Division one working day in advance to have irrigation turned off.



ATTACHMENT 'C'

TERMS OF PAYMENT

1. The Contractor's total compensation shall not exceed \$ 356,928.11 for Fairway Park, El Potrero Park, and Westbluff Park play equipment installed complete, per quote and HGAC contract.
2. The Contractor will submit one invoice to the CSD along with documentation evidencing services completed. At no time will the CSD pay for more services than have been satisfactorily completed and the CSD's determination of the amount due shall be final.
3. The CSD shall pay the Contractor for all invoiced, materials and labor as identified in the contract within thirty (30) days of completion, inspection and certification of compliance with national standards set by the American Society for Testing and Materials (ASTM) and Consumer Safety Commission (CPSC), performed by an approved Certified Playground Safety Inspector (CPSI).
4. Any fees for authorized professional services furnished by the Contractor which have not been paid or contested by the CSD within thirty (30) days of the CSD's receipt and of the invoice for such service will be subject to a late charge of one percent (1%) of the unpaid amount for each month for which payment has not been received by the Contractor. For invoices received prior to acceptance, the acceptance date will be utilized as the invoiced date.

Attachment D

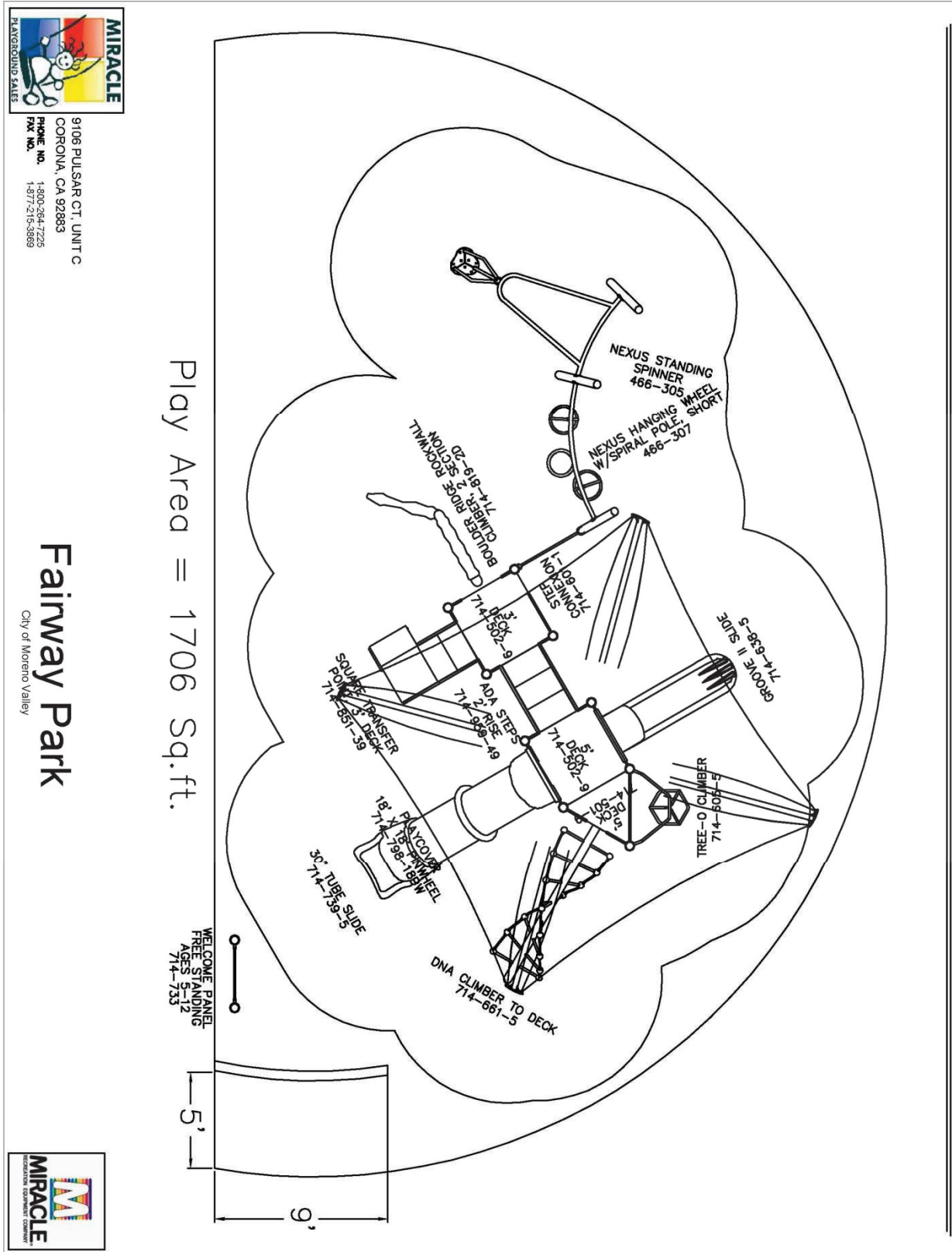

9106 PULSAR CT, UNIT C
 CORONA, CA 92883
 PHONE NO. 1-800-294-7225
 FAX NO. 1-877-216-3869

Fairway Park
 City of Moreno Valley



Attachment E



8845 Solution Center
Chicago IL 60677-8004

Phone # 800-264-7225
Fax # 877-215-3869

E-mail sales@miracleplayground.com
Web Site www.miracle-recreation.com

QUOTATION

Date	Estimate #
6/10/2013	2013-1392

Name / Address
City of Moreno Valley

**ALL PURCHASE ORDERS
MUST HAVE THIS ADDRESS:
8445 Solution Center
Chicago IL 60677-8004**

Project	Terms	Rep	FOB
3 Parks - HGAC	Net 30	Rob	factory

Item	Description	Qty	Rate	Total
Part A				
Miracle	Kids Choice/RNR play structure #CD197478 - El Potrero Park	1	63,927.20	63,927.20T
Miracle	Mega Tower play structure #Westbluff - West Bluff Park	1	146,694.00	146,694.00T
Miracle	Kids Choice play structure #CD197456 - Fairway Park	1	37,436.00	37,436.00T
Part B				
Fibar	Fibar Surfacing - 3 parks	1	20,221.46	20,221.46
Part C				
Freight	Commercial Freight - El Potrero Park	1	5,782.16	5,782.16
Freight	Commercial Freight - Westbluff Park	1	6,586.00	6,586.00
Freight	Commercial Freight - Fairway Park	1	3,195.22	3,195.22
Miracle	Miracle Discount - El Potrero	1	-7,589.50	-7,589.50T
Miracle	Miracle Discount - Westbluff Park	1	-44,004.20	-44,004.20T
Miracle	Miracle Discount - Fairway Park	1	-11,230.80	-11,230.80T
Installation	Installation of play equipment Fairway, Westbluff and El Potrero Parks	1	74,417.16	74,417.16
Installation	Installation of Fibar surfacing	1	6,066.30	6,066.30
Installation	Site work & equipment removal	1	33,608.49	33,608.49

This Quote is Valid for 30 Days	Subtotal
This quote shall not become binding until signed and delivered by both customer and Miracle Recreation "Miracle". To submit this offer, please sign and forward a complete copy of this quote via fax to 877-215-3869 or email sales@miracleplayground.com.	Sales Tax (8.0%)
	Total

THIS QUOTE IS LIMITED TO AND GOVERNED BY THE TERMS CONTAINED HEREIN. Miracle objects to any other terms proposed by the customer in writing or otherwise, as materials alterations, and all such proposed terms shall be void. Customer authorizes Miracle to ship the equipment and agrees to pay Miracle the total amount specified. Shipping terms are FOB the place of shipment via common carrier designated by Miracle. Payment terms are Net 30 days from invoice with approved credit and all charges are due and payable in full at 8445 Solution Center Lockbox 778445 Chicago IL 60677-8004 unless notified otherwise by Miracle in writing. Customer agrees to pay all additional service charges for past due invoices. Customer must provide proper tax exemption certificates to Miracle, and shall promptly pay and discharge all otherwise applicable taxes, license fees, levies and other impositions on the equipment at its own expense. Purchase orders and payments should be made to Miracle Recreation.



8845 Solution Center
Chicago IL 60677-8004

Phone # 800-264-7225
Fax # 877-215-3869

E-mail sales@miracleplayground.com
Web Site www.miracle-recreation.com

QUOTATION

Date	Estimate #
6/10/2013	2013-1392

Name / Address
City of Moreno Valley

ALL PURCHASE ORDERS
MUST HAVE THIS ADDRESS:
8445 Solution Center
Chicago IL 60677-8004

Project	Terms	Rep	FOB
3 Parks - HGAC	Net 30	Rob	factory

Item	Description	Qty	Rate	Total
Miracle	Bonding fees	1	7,000.00	7,000.00
HGAC	All pricing based on HGAC Contract. Please see attached interlocal contract.		0.00	0.00

This Quote is Valid for 30 Days This quote shall not become binding until signed and delivered by both customer and Miracle Recreation "Miracle". To submit this offer, please sign and forward a complete copy of this quote via fax to 877-215-3869 or email sales@miracleplayground.com.	Subtotal	\$342,109.49
	Sales Tax (8.0%)	\$14,818.62
	Total	\$356,928.11

THIS QUOTE IS LIMITED TO AND GOVERNED BY THE TERMS CONTAINED HEREIN. Miracle objects to any other terms proposed by the customer in writing or otherwise, as materials alterations, and all such proposed terms shall be void. Customer authorizes Miracle to ship the equipment and agrees to pay Miracle the total amount specified. Shipping terms are FOB the place of shipment via common carrier designated by Miracle. Payment terms are Net 30 days from invoice with approved credit and all charges are due and payable in full at 8445 Solution Center Lockbox 778445 Chicago IL 60677-8004 unless notified otherwise by Miracle in writing. Customer agrees to pay all additional service charges for past due invoices. Customer must provide proper tax exemption certificates to Miracle, and shall promptly pay and discharge all otherwise applicable taxes, license fees, levies and other impositions on the equipment at its own expense. Purchase orders and payments should be made to Miracle Recreation.

This page intentionally left blank.



*Save Time and Money Buying and Installing
Playground and Playground Surfacing
by Using H-GAC Purchasing Agreements*

PLAYGROUND EQUIPMENT AND SURFACING AVAILABLE

- Miracle Recreation Equipment Company
- HAGS
- Xccent
- Fibar Engineered Wood Fiber
- Fibar Pour In Place Rubber Surfacing

GENERAL INFORMATION

HGACBuy is a "Government-to-Government" procurement service available nationwide. Governmental entities have been procuring products and services through HGACBuy for over 30 years.

As a unit of local government assisting other local governments, HGACBuy strives to make the governmental procurement process more efficient by establishing competitively priced contracts for goods and services, and providing the customer service necessary to help its members achieve their procurement goals. All contracts available to members of HGACBuy have been **awarded by virtue of a public competitive procurement process compliant with state statutes.**

All units of local government, including non-profits providing governmental services, are eligible to join HGACBuy.

USING THE PROGRAM

Types of Participating Users

- Municipalities, Cities, Counties and State Agencies
- Councils of Government
- Schools, School Districts, Colleges, Universities
- Hospitals and Hospital Districts
- Emergency Medical Services and Services Districts

- Volunteer Fire Departments and Rural Fire Prevention Districts
- Special Law Enforcement Jurisdictions
- Judicial Courts & Districts
- Emergency Communications Districts
- Utility Districts (MUDs, WCIDs, Irrigation, etc.)
- Special Districts
- Authorities (Airport, Port, River, Water, Toll Road, etc.)
- State Agencies
- Not-for-Profit Corporations [501(c)(3)] providing government functions and services. (Special requirements apply: See Program Info/Executing an Interlocal Contract with HGACBuy)

The Texas Interlocal Cooperation Act (ILC)

Most States in the United States have either Interlocal Cooperation or Joint Powers authority to allow local governments in those states to join and participate in programs like HGACBuy.

State of California Statutes

California Code

California Government Code

Title 1 General

Division 7 Miscellaneous

Chapter 5 Joint Exercise of Powers

Article 1 Joint Powers Agreements

§ 6500 Government.

As used in this article, "public agency" includes, but is not limited to, the federal government or any federal department or agency, this state, another state or any state department or agency, a county, county board of education, county superintendent of schools, city, public corporation, public district, regional transportation commission of this state or another state, or any joint powers authority formed pursuant to this article by any of these agencies.

§ 6502 Government.

If authorized by their legislative or other governing bodies, two or more public agencies by agreement may jointly exercise any power common to the contracting parties, even though one or more of the contracting agencies may be located outside this state.

It shall not be necessary that any power common to the contracting parties be exercisable by each such contracting party with respect to the geographical area in

which such power is to be jointly exercised. For purposes of this section, two or more public agencies having the power to conduct agricultural, livestock, industrial, cultural, or other fairs or exhibitions shall be deemed to have common power with respect to any such fair or exhibition conducted by any one or more of such public agencies or by an entity created pursuant to a joint powers agreement entered into by such public agencies.

State of Arizona Statutes

Title 11 Counties

Chapter 7 Intergovernmental Operations

Article 3 Joint Exercise of Powers

§ 11-951. Definitions

For the purposes of this article, the term "public agency" shall include the federal government or any federal department or agency Indian tribe, this state, any other state, all departments, agencies, boards and commissions of this state or any other state, counties, school districts, cities, towns, all municipal corporations, and any other political subdivisions of the state or any other state.

§ 11-952. Intergovernmental agreements and contracts

If authorized by their legislative or other governing bodies, two or more public agencies by direct contract or agreement may contract for services or jointly exercise any powers common to the contracting parties and may enter into agreements with one another for joint or cooperative action or may form a separate legal entity, including a nonprofit corporation, to contract for or perform some or all of the services specified in the contract or agreement or exercise those powers jointly held by the contracting parties, except that if two or more school districts arrange to become contracting parties under the terms of this section, such contract shall first be approved by the state board of education

State of Nevada Statutes

Title 27 – Public Property and Purchasing

Chapter 232 Purchasing: Local Governments

General Provisions

§ NRS 332.015 "Local government" defined.

For the purpose of this chapter, unless the context otherwise requires, "local government" means:

1. Every political subdivision or other entity which has the right to levy or receive money from ad valorem taxes or other taxes or from any mandatory assessments, including counties, cities, towns, school districts and other districts organized pursuant to chapters 244, 309, 318, 379, 450, 473, 474, 539, 541, 543 and 555 of NRS.
2. The Las Vegas Valley Water District created pursuant to the provisions of chapter 167, Statutes of Nevada 1947, as amended.
3. County fair and recreation boards and convention authorities created pursuant to the provisions of NRS 244A.597 to 244A.655, inclusive.
4. District boards of health created pursuant to the provisions of NRS 439.370 to 439.410, inclusive.
5. The Nevada Rural Housing Authority.

§ NRS 332.195 Joinder or mutual use of contracts by local governments.

1. A governing body or its authorized representative may join or use the contracts of other local governments located within or outside this state with the authorization of the contracting vendor. The originally contracting local government is not liable for the obligations of the local government which joins or uses the contract.
2. A governing body or its authorized representative may join or use the contracts of the State of Nevada or another state with the authorization of the contracting vendor. The State of Nevada or other state is not liable for the obligations of the local government which joins or uses the contract.

§ NRS 332.115 Contracts not adapted to award by competitive bidding; purchase of equipment by local law enforcement agency or local fire department; purchase of goods commonly used by hospital.

1. Contracts which by their nature are not adapted to award by competitive bidding, including contracts for:
 - (m) Supplies, materials or equipment that are available pursuant to an agreement with a vendor that has entered into an agreement with the General Services Administration or another governmental agency located within or outside this state

In 1971, the Texas Legislature passed the Interlocal Cooperation Act [Texas Government Code, Title 7, Chapter 791] to promote activities among local governments across Texas. Any local government or non-profit providing government services may contract or agree with one or more local governments under the terms of this Act to conduct purchasing and other administrative functions. The following excerpt from the Act states that... "The Interlocal Cooperation Act's purpose is to improve the efficiency

and effectiveness of local governments by authorizing the fullest possible range of inter-governmental contracting authority at the local level including contracts between all political subdivisions of the state and agencies of the state.

Legal Authority

Governmental entities join HGACBuy by execution of an Interlocal Contract (ILC). By executing the ILC, the End User represents and warrants to H-GAC that (1) it is eligible to contract with H-GAC under the Act because it is one of the following: a qualifying non-profit corporation, county, municipality, special district, or other political subdivision of the State of Texas, or another state, and (2) it possesses adequate legal authority to enter into this Contract.

Scope of H-GAC's Professional Services

When participating in HGACBuy, members make their purchase orders out to, and directly pay, the HGACBuy contractor (Miracle Recreation). However, H-GAC does act as the designated purchasing agent on behalf of participating End Users by performing specific services including, but not limited to:

- Conducting research and surveys
- Developing specifications for each product/service
- Soliciting vendor participation
- Issuing specifications documents
- Conducting pre-bid/pre-proposal conferences
- Opening bid/proposal responses
- Evaluating responses
- Issuing Vendor Contracts awarded by the H-GAC Board of Directors
- Certifying contract validity
- Contracts Administration

Interlocal Contract Renewals

Provisions of the Interlocal Cooperation Act provide for annual renewal of Interlocal Contracts. The contract document issued by HGACBuy contains a provision for automatic annual renewal. Unless an updated contract document is requested, or statutory change occurs, the initial enactment could remain in effect in perpetuity. A permanent identification number is assigned to each End User contract.

Purchasing Statutes Applied to H-GAC Competitive Bid Process

Products offered through HGACBuy have been subjected to either the competitive bid or competitive proposal format based on Texas statutes for Councils of Governments under the Local Government Code Chapter 252. The 76th Legislature, Regular Session, added language that stipulates Councils of Governments shall specifically use "municipal bidding statutes". As administrator, H-GAC's rules of governance apply. In evaluating bid and proposal responses, HGACBuy takes into account any prospective contractor's ability to meet performance requirements. Factors considered include number and location of sales/service facilities, depth of staff, qualifications of technical support personnel, and business continuity. Contractors are expected to service all End Users participating in the Program wherever possible, practical, and not contrary to franchise or dealership agreements.

H-GAC Board of Directors Awards All Contracts

The Board of Directors composed of 35 elected officials awards all H-GAC cooperative purchasing contracts. As a political subdivision of the State of Texas, Board agenda are publicly posted in advance of public meetings. Board meetings are customarily held on the third Tuesday of each month in H-GAC Conference Room A, Second floor, 3555 Timmons Lane, Houston. The Houston-Galveston Area Council is one of Texas' 24 regional councils of governments.

Steps To Placing Purchase Orders Through HGACBuy

Step 1: (first time only) Execute the "Interlocal Contract" (ILC) and return 2 wet signed copies to H-GAC via mail. H-GAC will sign two copies and return one to the End User for their records. The ILC may be faxed to 713-993-4548 for expedited processing.

Step 2: Obtain specific product plans and quotes from Miracle Playground Sales, your local Miracle Recreation, HAGS, Fibar and Xccent representative at (800) 264-7225 or sales@miracleplayground.com.

Step 3: Prepare and submit your purchase order directly to:

Miracle Recreation c/o Miracle Playground Sales
9196 Stellar Ct

Corona CA, 92883
(800) 264-7225 Phone
(951) 676-8706 Fax
sales@miracleplayground.com

A copy of the order along with a copy of the Miracle Recreation written quotation shall be faxed or mailed to HGACBuy at FAX: 713-993-4548. Orders should include specific details regarding the purchase (i.e., name of the End User's contact person, shipping/delivery instructions, and installation details, if any). Miracle Recreation will then invoice End User for all purchases, and End User will pay the contractor directly following delivery and acceptance.

NOTE: Performance Bond

HGACBuy's contractual requirements no longer include a Performance Bond, and bid pricing should reflect this cost saving. However, Miracle Recreation must be prepared to offer a Performance Bond to cover any specific order, if so requested by End User. Miracle Recreation shall quote a price of 2.5% of the total order to End User for provision of any requested Performance Bond. If Performance Bond is requested by End User for a particular order, Miracle Recreation agrees to furnish the Performance Bond within ten (10) days of receipt of End User's purchase order.

HGACBuy Order Confirmation

On most contracts, when a copy of a purchase order is received (see Step 3 above), HGACBuy staff prepares an Order Confirmation, which is then sent to the Member and Miracle Recreation - authorizing Miracle recreation to proceed with the order. This Order Confirmation indicates that Miracle Recreation does have a valid contract with HGACBuy for the products contained on the order. Actual pricing is not verified on the Order Confirmation. For pricing verification prior to issuing the purchase order, contact HGACBuy staff.

Remitting End User Payments For Products and Services Rendered

The prompt payment requirements for products and services rendered through cooperative purchasing states that "...upon delivery of the goods and services purchased, and presentation by Miracle Recreation of a properly documented invoice, the End User shall promptly, and in any case within thirty (30) days, pay Miracle

Recreation the full amount of the invoice. All contracts between HGACBuy and Miracle Recreation require prompt payment upon delivery of products/services to an End User.

Ownership Passes Directly From Miracle Recreation to End Users

HGACBuy does not at any time take title to any product. Miracle Recreation assigns ownership directly to End Users.

Reimbursement of HGACBuy's Operational Costs

The HGACBuy program is solely funded through the assessment of an administrative fee paid by Miracle Recreation on each order.

End Users Invited to Attend Pre-Bid Conferences

HGACBuy schedules publicly announced pre-bid/pre-proposal specification conferences with manufacturers, distributors, representatives, and dealers for the various product categories offered. These conferences, held throughout each year, are widely attended by the various industry groups represented in the Program. End Users are invited to attend these conferences also.

3-Way Partnership At Work

The three-way partnership between HGACBuy, Program End Users, and Miracle Recreation is a very important relationship that provides vital links to ensure effective cooperative results. Clear, concise communication is essential to making the partnership effective and successful. The contact path includes all three parties: HGACBuy, End User, and Miracle Recreation.

H-GAC's Role:

HGACBuy's role is to conduct product research and surveys, write technical specifications, conduct pre-bid conferences, open bids, and evaluate responses. After contracts are awarded by the H-GAC Board, HGACBuy certifies contract validity, and administers contracts.

The End User's Role: End Users are expected to consult with Miracle Recreations'

representatives for the purpose of determining the exact requirements needed to serve constituents. End Users work with Miracle Recreation’s representatives to detail and complete all documentation required when submitting purchase orders.

Miracle Recreation’s Role:

HGACBuy relies upon Miracle Recreation and its local representatives to quickly respond to End User inquiries that provide detailed product information and pricing, including priced options for specific products. Miracle Playground Sales will work closely with each End User to meet specific constituent needs.

H-GAC’s Bid Notices

The Program's Coordinator for Specifications & Bids directs the bid/proposal cycle for products and services that HGACBuy desires to place under contract on behalf of Members. The near term schedule of procurements is posted on the HGACBuy website under Bid Notices.

Distribution of H-GAC Product Specifications

Product/service specifications and Invitations To Submit Competitive Bids/Proposals are distributed by email to all prospective responders that HGACBuy is aware of. The documents are also posted on the HGACBuy website, and the legally required notices are posted in newspapers, including minority-emphasis publications.

End User Benefits

HGACBuy offers significant benefits to participating End Users whether large, medium, or small size.

- Expedited procurement
- Volume purchasing discounts
- On-duty professional staff assistance
- Research and development of technical specifications
- Contract administration

Contacting HGACBuy

3555 Timmons Ln, Suite 120
Houston, TX 77027
Phone: 800-926-0234

Fax: 713-993-4548
Web: www.HGACBuy.org

Individual staff phone numbers and emails may be found on the HGACBuy website under Program Staff.

JOINING HGACBUY BY EXECUTING AN INTERLOCAL CONTRACT (ILC)

In order to participate in HGACBuy, you must:

1. Be a state agency, county, municipality, special district, or other political subdivision of a state, or a qualifying non-profit corporation (providing one or more governmental function or service); and
2. Possess legal authority to enter into the Contract.

End User warrants that both requirements are fulfilled by execution of an ILC.

Steps For Completion And Processing:

Step 1:

Print two copies of the appropriate HGACBuy ILC Form and fill in all required information, including the date your governing body authorized the ILC.

Step 2:

Secure signature by an individual with authority to contractually bind your entity.

Step 3:

Send both documents **with original signatures** to HGACBuy at the address indicated on the ILC Form.

Step 4:

HGACBuy will execute both copies of the contract and return one to you.

Special Requirements For Non-Profit Corporations:

Qualifying non-profit corporations providing one or more government services (e.g. Volunteer Fire Departments, Emergency Medical Services) must also submit the following items together with the ILC documents:

Copy of 501(c)(3) Form

Copy of Charter and By-Laws highlighting section(s) demonstrating that your organization performs a governmental service.

A letter describing the governmental service(s) that your organization performs. (This requirement does not apply to Volunteer Fire Departments or organizations providing Emergency Medical Services).

Fax copies of Interlocal Contracts will be accepted and processed subject to the same requirements as original documents.

FREQUENTLY ASKED QUESTIONS

Q: What is H-GAC?

A: The Houston-Galveston Area Council (H-GAC) is a regional council of governments operating under the laws of the State of Texas and governed by a board comprised of 35 elected officials from the 13 county region. The H-GAC Board awards all contracts, which can then be made available to local governments nationwide thru HGACBuy.

Q: How does HGACBuy work?

A: Government entities join by executing an Interlocal Contract to participate in HGACBuy. This document sets out the conditions, requirements and processes through which an entity's purchase orders are received, confirmed to contract and processed.

Q: Can my entity purchase through HGACBuy?

A: The Texas Interlocal Cooperation Act permits joint participation by local governments, states, state agencies, and certain non-profit corporations. Most states have interlocal cooperation authority or other joint power provisions that allow participation in cooperative activities.

Q: I have to advertise for bids therefore I can't purchase thru HGACBuy.

A: HGACBuy uses mass circulation, minority emphasis print media, and Internet

services to post legal notices and bid solicitations. Therefore, posting of public notices to solicit bids and the formal competitive bid process are satisfied thru HGACBuy procedures.

Q: What other services are offered through the HGACBuy program?

A: Researching products, writing specifications, holding pre-bid conferences, assisting with order placement, contacting vendor reps, helping to resolve order issues, and reviewing and certifying purchase orders to confirm compliance with any specific HGACBuy contract.

Q: What is the difference between HGACBuy and some other cooperatives?

A: HGACBuy is a unit of local government and a political subdivision of the State of Texas. The HGACBuy Program is over 30 years old and specializes in high ticket, capital intensive, products and services that require technical, detailed specifications and extensive professional skills to evaluate bid responses. All products offered through HGACBuy have been awarded by virtue of a public competitive process. There are no annual membership dues required to purchase thru HGACBuy.

Q: Where do I find information on products offered through HGACBuy?

A: Access HGACBuy's web site at www.hgacbuy.org for a complete listing of products with descriptions and prices and/or contractors and contacts.

Q: What products are available thru HGACBuy?

A: Primarily, products that are utilized in Public Safety, Public Works, and Communications, in addition to professional consulting, personnel and financing services. A wide variety of capital equipment is under contract, and thru a unique feature of HGACBuy it can be customized through the use of published and unpublished options to fit your specifications and requirements.

Q: Can I purchase on-line?

A: Because of the nature of most of the products and services we have under contract, we prefer that you speak with a contractor's representative and get a detailed price quote before placing an order. This is to insure that you get what you want, configured

like you want it. Use the HGACBuy website to for basic information and to get the contractor's telephone and email address. After you receive your written quotation and have reviewed it, prepare your purchase order to the Contractor and fax a copy to HGACBuy.

Q: What does it cost to join HGACBuy? How is HGACBuy funded?

A: HGACBuy is a self-funded "Enterprise Fund" government agency, self-supported thru an administrative fee assessed to the contractor. An "Order Processing Charge" (Administrative Fee) will appear on quotation forms for purchases of motor vehicles in the State of Texas in accordance with State of Texas, Department of Transportation - Division of Motor Vehicles requirements.

Q: What are the benefits of HGACBuy? I want to inform my elected officials and staff:

A: We give you access to volume purchasing and discounts. • We put over 200 years of combined purchasing experience to work on your behalf. • We write technical specifications eliminate the need to hire consultants for that purpose. • We absorb the costs associated with publishing legal notices. • We offer you an expedited procurement process so you need not be delayed for months preparing specifications and satisfying all of the other requirements for competitive bids and proposals.

CURRENT USERS OF H-GAC

End User	City
Baldwin Park, City of (CA)	Baldwin Park
Berkeley, City of (CA)	Berkeley
Chico, City of (CA)	Chico
Contra Costa Community College District (CA)	Martinez
Coronado, City of (CA)	Coronado
Fortuna, City of (CA)	Fortuna
Fresno, City of (CA)	Fresno
Gardena, City of (CA)	Gardena
Glendale, City of (California)	Glendale
Humboldt Community Services District (CA)	Eureka
Long Beach Public Transportation Co. (CA)	Long Beach
Los Angeles Unified School District (CA)	Pico Rivera
Manteca, City of (CA)	Manteca
Mendocino, County of (CA)	Ukiah

Monrovia, City of (CA)	Monrovia
Palm Springs, City of (CA)	Palm Springs
Placer County Water Agency (CA)	Auburn
Placer, County of (CA)	Auburn
Porterville, City of (CA)	Porterville
Rancho Cucamonga, City of (CA)	Rancho Cucamonga
Riverside, City of (CA)	Riverside
Sacramento, City of (CA)	Sacramento
Salinas, City of (CA)	Salinas
San Buenaventura, City of (CA)	Ventura
San Diego, County of	San Diego
San Luis Obispo, County of (CA)	San Luis Obispo
San Mateo, City of (CA)	San Mateo
San Miguel Consolidated Fire Protection District (CA)	Spring Valley
Shasta County (CA)	Redding
South Tahoe Public Utility District (CA)	South Lake Tahoe
Stanislaus County (CA)	Modesto
State Center Community College (CA)	Fresno
Truckee, Town of (CA)	Truckee
Ukiah, City of (CA)	Ukiah
Ventura, County of (CA)	Ventura
Wasco, City of (CA)	Wasco

End User	City
Avondale, City of (AZ)	Avondale
Buckeye, Town of (AZ)	Buckeye
Casa Grande, City of (AZ)	Casa Grande
Cave Creek, Town of (AZ)	Cave Creek
Chandler, City of	Chandler
Coolidge, City of (AZ)	Coolidge
El Mirage, City of (AZ)	El Mirage
Florence, Town of (AZ)	Florence
Gilbert, Town of (AZ)	Gilbert
Glendale, City of (AZ)	Glendale
Goodyear, City of (AZ)	Goodyear
Lake Havasu City (AZ)	Lake Havasu
Marana, Town of (AZ)	Marana
Maricopa, City of (AZ)	Maricopa
Metro Water District (AZ)	Tucson
Mohave County (AZ)	Kingman
Nogales, City of (AZ)	Nogales
Northwest Fire District (AZ)	Tucson
Oro Valley, Town of (AZ)	Oro Valley

Page, City of (AZ)	Page
Payson, Town of (AZ)	Payson
Peoria, City of (AZ)	Peoria
Phoenix, City of (AZ)	Phoenix
Prescott Valley, The Town of (AZ)	Prescott Valley
Prescott, City of (AZ)	Prescott
Queen Creek, Town of (AZ)	Queen Creek
San Luis, City of (AZ)	San Luis
Scottsdale, City of (AZ)	Scottsdale
Sedona, City of (AZ)	Sedona
Show Low, City of (AZ)	Show Low
Sierra Vista, City of (AZ)	Sierra Vista
Somerton, City of (AZ)	Somerton
Sun City West Fire District (AZ)	Sun City West
Sun Lakes Fire District (AZ)	Sun Lakes
Sunsites-Pearce Volunteer Fire Department (AZ)	Pearce
Surprise, City of (AZ)	Surprise
Tempe, City of (AZ)	Tempe
Tucson Airport Authority (AZ)	Tucson
Wellton, Town of (AZ)	Wellton
Wickenburg, Town of (AZ)	Wickenburg
Yuma County (AZ)	Yuma
Yuma, City of (AZ)	Yuma

End User	City
Carson City, City of (NV)	Carson City
Henderson, City of (NV)	Henderson
Nye County (NV)	Tonopah

PARK AND PLAYGROUND EQUIPMENT CONTRACT INFORMATION

Contract No.: PR11-08

Effective Date: Nov 1, 2008 to Oct 31, 2010

RE: Playground and safety surfacing equipment:

- (1) Equipment shall be in compliance with CPSC safety standards as expressed in CPSC Publication No. 325: Handbook for Public Playground Safety (most recent version) and ASTM F1487: Standard Consumer Safety Performance Specification for Playground Equipment for Public Use (or most current version).
- (2) Playground equipment manufacturers possess IPEMA certification. Surfacing manufacturers shall possess IPEMA certification OR shall provide evidence of compliance to the following ASTM standards: for wood surfacing: F2075: Standard Specification for Engineered Wood Fiber for Use as Playground Safety Surface Under and Around Playground Equipment and F1292: Standard Specification for Impact Attenuation of Surface Systems, Under and Around Playground Equipment (most current versions).
- (3) Dealers shall have capability of passing a formal NPSI-CPSI audit if required by HGAC member (by dealer's in-house CPSI certified staff or by third party CPSI-certified auditor).

PRODUCT CODE	MANUFACTURER - CATALOG/PRICE SHEET	CONTRACTOR	DISCOUNT
PR20	Fibar Systems (The Fibar Group, LLC): Fibar Systems Playground Surfacing Systems Catalog <ul style="list-style-type: none">- Engineered wood fiber systems- Pour In Place Rubber Surfacing	Miracle Recreation	5%
PR25	Hags Aneby AB: Hags USA Catalog	Miracle Recreation	5%
PR36	Miracle Recreation Equip. Co.: Recreation and Playground Catalog	Miracle Recreation	15%
PR87	Xccent, Inc.: Xccent Catalog	Miracle Recreation	5%

PRODUCTS AND SERVICES AVAILABLE

Services in Contract

Installation of Miracle Hags or Xccent – 30% of list price

Freight and Tax added based on dollars, weight and distance

Installation of Fibar Engineered Wood Fiber – quoted per job

Installation of Pour In Place Rubber Surfacing – Included in price above

Related Extra Services

Can be added to contract up to 25% of the list price of the Products and Services in Contract.

GENERAL PURPOSE & EMERGENCY VEHICLES	INFRASTRUCTURE EQUIPMENT & SERVICES	COMMUNICATIONS EQUIPMENT & SERVICES	GROUPS FACILITIES & PARKS EQUIPMENT	PUBLIC WORKS EQUIPMENT	EMERGENCY EQUIPMENT & SUPPLIES	CONSULTING LEASING & STAFFING SERVICES	EMERGENCY PREPAREDNESS & DISASTER RECOVERY
COOPERATIVE ENERGY PURCHASING							

You are here: [Home](#) > [Information About The Program](#) > List of End Users

INFORMATION ABOUT THE PROGRAM

LIST OF END USERS

[Alaska](#) | [Alabama](#) | [Arkansas](#) | [Arizona](#) | [California](#) | [Colorado](#) | [Connecticut](#) | [Delaware](#) | [Florida](#) | [Georgia](#) | [Idaho](#) | [Illinois](#) | [Iowa](#) | [Indiana](#) | [Kansas](#) | [Kentucky](#) | [Louisiana](#) | [Maryland](#) | [Maine](#) | [Massachusetts](#) | [Michigan](#) | [Minnesota](#) | [Missouri](#) | [Mississippi](#) | [Montana](#) | [North Carolina](#) | [North Dakota](#) | [Nebraska](#) | [New Jersey](#) | [New Mexico](#) | [Nevada](#) | [New York](#) | [Ohio](#) | [Oklahoma](#) | [Oregon](#) | [Pennsylvania](#) | [Rhode Island](#) | [South Carolina](#) | [South Dakota](#) | [Tennessee](#) | [Texas](#) | [Utah](#) | [Vermont](#) | [Virginia](#) | [Washington](#) | [West Virginia](#) | [Wisconsin](#) | [Wyoming](#)

End User	City
California	
Big Oak Flat-Groveland Unified School District (CA)	Groveland
Bonita Unified School District (CA)	San Dimas
Borrego Springs Fire Protection District (CA)	Borrego Springs
California Congress of Parents and Teachers 31st District PTSA	Van Nuys
California State Polytechnic University Pomona (CA)	Pomona
California State University Fullerton (CA)	Fullerton
Campbell Union School District (CA)	Campbell
Central School District (CA)	Rancho Cucamonga
Chico Unified School District (CA)	Chico
City of Alameda (CA)	Alameda
City of Albany (CA)	Albany
City of Anaheim (CA)	Anaheim
City of Auburn (CA)	Auburn
City of Baldwin Park (CA)	Baldwin Park
City of Bell Gardens (CA)	Bell Gardens
City of Berkeley (CA)	Berkeley
City of Brentwood (CA)	Brentwood
City of Burbank (CA)	Burbank
City of Calabasas (CA)	Calabasas
City of Carlsbad (CA)	Carlsbad
City of Carmel (CA)	Carmel
City of Chico (CA)	Chico
City of Commerce (CA)	Commerce
City of Corning (CA)	Corning
City of Corona (CA)	Corona
City of Coronado (CA)	Coronado
City of Culver City (CA)	Culver City
City of Department of Airport Los Angeles (CA)	Los Angeles
City of Dinuba (CA)	Dinuba
City of Dixon (CA)	Dixon
City of Eureka (CA)	Eureka
City of Fontana (CA)	Fontana
City of Fortuna (CA)	Fortuna
City of Fountain Valley (CA)	Fountain Valley
City of Fresno (CA)	Fresno
City of Gardena (CA)	Gardena
City of Glendale (CA)	Glendale
City of Imperial Beach (CA)	Imperial Beach
City of Irvine (CA)	Irvine
City of La Cañada Flintridge (CA)	La Cañada Flintridge
City of La Mesa (CA)	La Mesa
City of Lakewood (CA)	Lakewood
City of Live Oak (CA)	Live Oak
City of Long Beach (CA)	Long Beach
City of Los Angeles (CA)	Los Angeles
City of Madera (CA)	Madera
City of Manteca (CA)	Manteca
City of Merced (CA)	Merced
City of Monrovia (CA)	Monrovia
City of Monterey Park (CA)	Monterey Park
City of Moreno Valley (CA)	Moreno Valley
City of Oakland (CA)	Oakland
City of Ontario (CA)	Ontario
City of Orange (CA)	Orange
City of Orinda (CA)	Orinda
City of Oroville (CA)	Oroville
City of Oxnard (CA)	Oxnard
City of Palm Springs (CA)	Palm Springs
City of Palmdale (CA)	Palmdale
City of Pasadena (CA)	Pasadena
City of Porterville (CA)	Porterville
City of Portola (CA)	Portola
City of Rancho Cucamonga (CA)	Rancho Cucamonga
City of Riverside (CA)	Riverside
City of Roseville (CA)	Roseville
City of Sacramento (CA)	Sacramento
City of Salinas (CA)	Salinas
City of San Buenaventura (CA)	Ventura
City of San Clemente (CA)	San Clemente
City of San Diego (CA)	San Diego
City of San Leandro (CA)	San Leandro
City of San Mateo (CA)	San Mateo
City of San Ramon (CA)	San Ramon
City of Santa Barbara (CA)	Santa Barbara
City of Santa Clarita (CA)	Santa Clarita
City of Santa Rosa (CA)	Santa Rosa
City of Sausalito (CA)	Sausalito

City of South Gate (CA)	South Gate
City of South San Francisco (CA)	South San Francisco
City of Stockton (CA)	Stackton
City of Ukiah (CA)	Ukiah
City of Visalia (CA)	Visalia
City of Vista (CA)	Vista
City of Westlake Village(CA)	Westlake Village
City of Wheatland (CA)	Wheatland
City of Woodland (CA)	Woodland
City of Yreka (CA)	Yreka
Cold Spring School District (CA)	Santa Barbara
Community Health Center Network, Inc. (CA)	San Leandro
Contra Costa Community College District (CA)	Martinez
Contra Costa County (CA)	Martinez
County of Kings (CA)	Hanford
County of Mendocino (CA)	Ukiah
County of Nevada (CA)	Nevada City
County of Placer (CA)	Auburn
County of Sacramento (CA)	Sacramento
County of San Benito (CA)	Hollister
County of San Diego (CA)	San Diego
County of San Luis Obispo (CA)	San Luis Obispo
County of Ventura (CA)	Ventura
Denair Community Services District (CA)	Denair
El Dorado Irrigation District (CA)	Placerville
Gold Coast Transit (CA)	Oxnard
Housing Authority of the County of Alameda (CA)	Hayward
Humboldt Community Services District (CA)	Eureka
Korean Churches for Community Development (CA)	Los Angeles
Long Beach Public Transportation Co. (CA)	Long Beach
Long Beach Water Department (CA)	Long Beach
Los Angeles Child Guidance Clinic (CA)	Los Angeles
Los Angeles Unified School District (CA)	Pico Rivera
Milpitas Unified School District (CA)	Milpitas
Mojave Public Utility District (CA)	Mojave
Monterey County (CA)	Salinas
National Community Renaissance of California (CA)	Rancho Cucamonga
North County Fire Protection District (CA)	Fallbrook
Placer County Water Agency (CA)	Auburn
River Oak Center for Children (CA)	Sacramento
Sacramento Area Sewer District (CA)	Sacramento
Sacramento Children's Home (CA)	Sacramento
San Miguel Consolidated Fire Protection District (CA)	Spring Valley
Santa Barbara Unified School District (CA)	Santa Barbara
Santa Cruz Couty (CA)	Watsonville
Shasta County (CA)	Redding
Skid Row Housing Trust (CA)	Los Angeles
Solano County (CA)	Fairfield
South Placer Fire District (CA)	Granite Bay
South Tahoe Public Utility District (CA)	South Lake Tahoe
Southern California Logistics Airport Authority (CA)	Victorville
Southwest Transportation Agency (CA)	Caruthers
St. Vincent de Paul Village, Inc. (CA)	San Diego
Stanislaus County (CA)	Modesto
Stanislaus County Office of Education (CA)	Modesto
State Center Community College (CA)	Fresno
Sunline Transit Agency (CA)	Thousand Palms
Sunnyvale School District (CA)	Sunnyvale
Survivors of Torture, Intl. (CA)	San Diego
Thermalito Water and Sewer District (CA)	Oroville
Town of Apple Valley (CA)	Apple Valley
Town of Hillsborough (CA)	Hillsborough
Town of Los Gatos (CA)	Los Gatos
Town of Truckee (CA)	Truckee
Union Sanitary District (CA)	Union City
Victor Valley Transit Authority (CA)	Hesperia
Vista Hill Foundation (CA)	San Diego
West Bay Sanitary District (CA)	Menlo Park
Wilton Fire Protection District (CA)	Wilton
Yolo County (CA)	Woodland



[Back to Top](#)

Copyright © 2013 H-GAC. All Rights Reserved.

This page intentionally left blank.



INTERLOCAL CONTRACT FOR COOPERATIVE PURCHASING

ILC No. 09-2331 Permanent Number assigned by H-GAC

THIS INTERLOCAL CONTRACT ("Contract"), made and entered into pursuant to the Texas Interlocal Cooperation Act, Chapter 791, Texas Government Code (the "Act"), by and between the Houston-Galveston Area Council, hereinafter referred to as "H-GAC," having its principal place of business at 3555 Timmons Lane, Suite 120, Houston, Texas 77027, and * City of MORENO VALLEY, CA, a local government, a state agency, or a non-profit corporation created and operated to provide one or more governmental functions and services, hereinafter referred to as "End User," having its principal place of business at * P.O. Box 88005, MORENO VALLEY, CA 92552

WITNESSETH

WHEREAS, H-GAC is a regional planning commission and political subdivision of the State of Texas operating under Chapter 391, Texas Local Government Code; and

WHEREAS, pursuant to the Act, H-GAC is authorized to contract with eligible entities to perform governmental functions and services, including the purchase of goods and services; and

WHEREAS, in reliance on such authority, H-GAC has instituted a cooperative purchasing program under which it contracts with eligible entities under the Act; and

WHEREAS, End User has represented that it is an eligible entity under the Act, that its governing body has authorized this Contract on * 5/12/09 (Date), and that it desires to contract with H-GAC on the terms set forth below;

NOW, THEREFORE, H-GAC and the End User do hereby agree as follows:

ARTICLE 1: LEGAL AUTHORITY

The End User represents and warrants to H-GAC that (1) it is eligible to contract with H-GAC under the Act because it is one of the following: a local government, as defined in the Act (a county, a municipality, a special district, or other political subdivision of the State of Texas or any other state), or a combination of two or more of those entities, a state agency (an agency of the State of Texas as defined in Section 771.002 of the Texas Government Code, or a similar agency of another state), or a non-profit corporation created and operated to provide one or more governmental functions and services, and (2) it possesses adequate legal authority to enter into this Contract.

ARTICLE 2: APPLICABLE LAWS

H-GAC and the End User agree to conduct all activities under this Contract in accordance with all applicable rules, regulations, and ordinances and laws in effect or promulgated during the term of this Contract.

ARTICLE 3: WHOLE AGREEMENT

This Contract and any attachments, as provided herein, constitute the complete contract between the parties hereto, and supersede any and all oral and written agreements between the parties relating to matters herein.

ARTICLE 4: PERFORMANCE PERIOD

The period of this Contract shall be for the balance of the fiscal year of the End User, which began * July 1st, 2009 and ends * JUNE 30th, 2010. This Contract shall thereafter automatically be renewed annually for each succeeding fiscal year, provided that such renewal shall not have the effect of extending the period in which the End User may make any payment due an H-GAC contractor beyond the fiscal year in which such obligation was incurred under this Contract.

ARTICLE 5: SCOPE OF SERVICES

The End User appoints H-GAC its true and lawful purchasing agent for the purchase of certain products and services through the H-GAC Cooperative Purchasing Program. End User will access the Program through HGACBuy.com and by submission of any duly executed purchase order, in the form prescribed by H-GAC to a contractor having a valid contract with H-GAC. All purchases hereunder shall be in accordance with specifications and contract terms and pricing established by H-GAC. Ownership (title) to products purchased through H-GAC shall transfer directly from the contractor to the End User.

(over)

ARTICLE 6: PAYMENTS

H-GAC will confirm each order and issue notice to contractor to proceed. Upon delivery of goods or services purchased, and presentation of a properly documented invoice, the End User shall promptly, and in any case within thirty (30) days, pay H-GAC's contractor the full amount of the invoice. All payments for goods or services will be made from current revenues available to the paying party. In no event shall H-GAC have any financial liability to the End User for any goods or services End User procures from an H-GAC contractor.

ARTICLE 7: CHANGES AND AMENDMENTS

This Contract may be amended only by a written amendment executed by both parties, except that any alternations, additions, or deletions to the terms of this Contract which are required by changes in Federal and State law or regulations are automatically incorporated into this Contract without written amendment hereto and shall become effective on the date designated by such law or regulation.

H-GAC reserves the right to make changes in the scope of products and services offered through the H-GAC Cooperative Purchasing Program to be performed hereunder.

ARTICLE 8: TERMINATION PROCEDURES

H-GAC or the End User may cancel this Contract at any time upon thirty (30) days written notice by certified mail to the other party to this Contract. The obligations of the End User, including its obligation to pay H-GAC's contractor for all costs incurred under this Contract prior to such notice shall survive such cancellation, as well as any other obligation incurred under this Contract, until performed or discharged by the End User.

ARTICLE 9: SEVERABILITY

All parties agree that should any provision of this Contract be determined to be invalid or unenforceable, such determination shall not affect any other term of this Contract, which shall continue in full force and effect.

ARTICLE 10: FORCE MAJEURE

To the extent that either party to this Contract shall be wholly or partially prevented from the performance within the term specified of any obligation or duty placed on such party by reason of or through strikes, stoppage of labor, riot, fire, flood, acts of war, insurrection, accident, order of any court, act of God, or specific cause reasonably beyond the party's control and not attributable to its neglect or nonfeasance, in such event, the time for the performance of such obligation or duty shall be suspended until such disability to perform is removed; provided, however, force majeure shall not excuse an obligation solely to pay funds. Determination of force majeure shall rest solely with H-GAC.

ARTICLE 11: VENUE

Disputes between procuring party and Vendor are to be resolved in accord with the law and venue rules of the State of purchase.

THIS INSTRUMENT HAS BEEN EXECUTED IN TWO ORIGINALS BY THE PARTIES HERETO AS FOLLOWS:

* CITY OF MORENO VALLEY
 Name of End User (local government, agency, or non-profit corporation)

* P.O. Box 88005
 Mailing Address

* MORENO VALLEY CA 92552
 City State ZIP Code

* By: [Signature]
 Signature of chief elected or appointed official

Rix SKONBERG 11/30/09
 Typed Name & Title of Signatory Date
 Purchasing & Facilities Mgr.

Houston-Galveston Area Council
 3555 Timmons Lane, Suite 120, Houston, TX 77027

By: [Signature]
 Executive Director

Date: 12-21-09

Attest: [Signature]
 Manager

Date: 15, 2009

*Denotes required fields

rev. 7/07

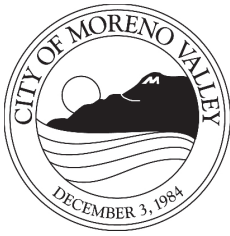

APPROVALS	
BUDGET OFFICER	<i>me</i>
CITY ATTORNEY	<i>SMB</i>
CITY MANAGER	<i>d</i>

Report to City Council

TO: Mayor and City Council, acting in their capacity as President and Board of Directors of the Moreno Valley Community Services District

FROM: Michael McCarty, Director of Parks and Community Services

AGENDA DATE: August 27, 2013

TITLE: AMEND THE CONTRACT WITH THINK TOGETHER, INC., TO OPERATE DAY-TO-DAY ACTIVITIES AND FUNCTIONS INVOLVING THE CITY'S AFTER SCHOOL EDUCATION AND SAFETY (ASES) GRANT PROGRAM FOR FISCAL YEAR 2013-14 THROUGH FISCAL YEAR 2015-16

RECOMMENDED ACTION

Recommendations:

1. Authorize the City Manager to amend the contract entered into with THINK Together, Inc., on April 26, 2011, to operate day-to-day activities and functions of the City's Prop 49 state-funded ASES after school grant program, as outlined within this document.
2. Authorize the additional revenue and expense budgets in the ASES Program Grant Fund (Fund 2202) for the ASES Grant Program in the amount of \$520,050, respectively, upon approval of the contract amendment with THINK Together, Inc.

BACKGROUND

The After School Learning and Safe Neighborhoods Partnership Program began in 1998. Proposition 49 was passed by California voters in 2002, changing the name to After School Education and Safety (ASES) program, and effective July 1, 2006 increasing annual funding from \$121 million up to \$550 million. Applicants awarded an ASES grant receive a three-year renewable direct grant awarded in one-year increments.

As a result of staff's efforts to provide an increased level of service for Moreno Valley youth through diverse funding, staff submitted competitive grant applications in

partnership with Moreno Valley Unified School District (MVUSD) and Val Verde Unified School District (VVUSD) to the After School Partnerships Office, CDE. The City of Moreno Valley is the fiscal agent for the grant. The City of Moreno Valley Parks and Community Services Department received a three-year direct grant that was awarded in three one-year increments of \$4,950,000 from the State Department of Education. Grant funding has been reduced since 2006 directly relating to participation numbers and as a result was at \$4,296,909.

A two-year contract with THINK Together was approved on April 26, 2011 in the amount of \$4,296,909 per year to operate the City's ASES grant program for 2011 through 2013, along with two subsequent automatic 3-year renewals for the next two ASES grant cycles.

DISCUSSION

THINK Together has successfully provided comprehensive after school programming, serving the City's After School Education and Safety Grant (ASES) at 43 sites in MVUSD and VVUSD for the 2011-2012 and 2012-2013 school years. Attendance increased, and there were waiting lists at several of the school sites.

Due to the increased attendance, the Parks and Community Services Department applied for and received from the California Department of Education \$262,941 additional ASES funding to increase the number of students served at eleven school sites for fiscal year 2012-13. An amendment to the THINK Together contract to include an additional \$247,766 was approved by Council on June 26, 2012.

The Parks and Community Services Department applied for additional funding to increase the number of students at nine middle school ASES sites for fiscal year 2013-2014 through fiscal year 2015-2016. The California Department of Education posted the funding results, and the City of Moreno Valley will receive an additional \$520,050 per fiscal year.

Attachment 1 is the amended payment schedule for THINK Together. Also, due to staffing changes with THINK Together, an additional \$30,350 will revert back to the City per the benefit allowance agreement on page 3 of the contract.

ALTERNATIVES

1. Authorize the City Manager to amend the contract with THINK Together, Inc., to operate day-to-day activities and functions of the City's Prop 49 state-funded ASES after school grant program, as outlined within this document.
2. Do not authorize amendment to the contract and provide direction to staff.

FISCAL IMPACT

This amendment will increase the amount for administration of the contract by \$30,350 (2202-50-58-75312-611110); \$489,700 will be added to Other Contractual - Other

(2202-50-58-75312-625099). All grant funds must be used for ASES Grant Expenditures. There is no impact to the General Fund.

Revenue/Expenditure Appropriations

Description	Fund	GL Account No.	Type (Rev/Exp)	Amount
Receipt of Grant	ASES	2202-50-58-75312-486000	Rev	\$520,050
Administration	ASES	2202-50-58-75312-611110	Exp	\$30,350
Contract Services	ASES	2202-50-58-75312-625099	Exp	\$489,700

Budget Adjustments

Description	Fund	GL Account No.	Type (Rev/Exp)	FYs 13/14 and 14/15 Budgets	Proposed FYs 13/14 and 14/15 Adjustments	FYs 13/14 and 14/15 Amended Budgets
Receipt of Grant	ASES	2202-50-58-75312-486000	Rev	\$4,559,850	\$520,050	\$5,079,900
Administration	ASES	2202-50-58-75312-611110	Exp	\$47,700	\$30,350	\$78,050
Contract Services	ASES	2202-50-58-75312-625099	Exp	\$4,461,075	\$489,700	\$4,950,775

SUMMARY

Parks and Community Services Department staff believe that increasing the contract amount with THINK Together is in the best interest of the City. This will allow the City to serve approximately 385 more students. Not only do after school programs offer constructive alternatives to gangs, drugs, and crime, but can also help improve school day attendance, increase academic achievement, and boost graduation rates.

NOTIFICATION

Posting of the agenda.

ATTACHMENTS

Attachment 1: Amended Contract as to form

Prepared By:
Patty Grube
Management Analyst I

Department Head Approval:
Michael McCarty
Director of Parks and Community Services

Council Action	
Approved as requested:	Referred to:
Approved as amended:	For:
Denied:	Continued until:
Other:	Hearing set for:

This page intentionally left blank.

**AMENDMENT TO
THINK TOGETHER, INC., AGREEMENT**

This Second Amendment to the THINK Together, Inc., Agreement (hereinafter referred to as "Agreement") is made and entered into between the Community Services District of the City of Moreno Valley (hereinafter referred to as "CSD"), and THINK Together, Inc., (hereinafter referred to as "Contractor") and is effective the date the CSD signs this Amendment.

Whereas, the CSD and Contractor entered into an Agreement dated July 13, 2011.

Whereas, the Contractor is providing operation of the After School Education and Safety Grant Program (hereinafter referred to as "ASES").

Whereas, the CSD desires to renew the Agreement with the Contractor for the July 1, 2013 to June 30, 2016 grant cycle.

Whereas, the Contractor desires to continue to operate the ASES.

Section 1 – Amendment to THINK Together, Inc., Contract

1.1 Pursuant to Page 1 of the Agreement, the Contractor will continue to provide services, July 1, 2013 to June 30, 2016, for the ASES using the first of two (2) subsequent automatic three (3)-year renewals.

Pursuant to Page 3 of the Agreement, the Contractor will not pay the monthly benefit allowance of \$1,264.58 to one of the Program Coordinator positions and the Sr. Administrative Analyst. The annual amount of \$30,350 will revert back to the CSD. Schedule B has been revised to reflect this change, attached hereto.

Pursuant to Page 4 of the Agreement, the Contractor's compensation shall be changed to 100% of the grant award from California Department of Education (CDE), less \$145,525 for administrative costs, according to Schedule A, attached hereto.

Section 2 – Other Terms to Remain

2.1 Except as otherwise specifically provided in this Amendment, the terms and conditions of the Agreement shall remain in full force and effect.

IN WITNESS HEREOF, the parties have each caused their authorized representative to execute this Agreement.

SIGNATURE PAGE TO FOLLOW:

Community Services District of the
City of Moreno Valley

THINK Together, Inc.

BY: _____
City Manager

BY: _____
Randy Barth

TITLE: _____
Founder and CEO

Date

Date

<u>INTERNAL USE ONLY</u>
ATTEST:
_____ City Clerk <i>(only needed if Mayor signs)</i>
APPROVED AS TO LEGAL FORM:
_____ City Attorney
_____ Date
RECOMMENDED FOR APPROVAL:
_____ Department Head
_____ Date

Schedule A
Payment Schedule

Ten monthly payments, due on the 1st of each month from September 1 through June 1, according to the following:

School Name	Components	Amount Awarded	Total Payment to THINK Together	Monthly Payment Amount (x10)
			(after \$145,525 carve-out)	10%
Armada Elementary	ASES After School Base	\$ 112,500.00	\$ 109,277.19	\$ 10,927.72
Badger Springs Middle	ASES After School Base	150,000.00	145,702.92	14,570.29
Bear Valley Elementary	ASES After School Base	112,500.00	109,277.19	10,927.72
Box Springs Elementary	ASES After School Base	112,500.00	109,277.19	10,927.72
Butterfield Elementary	ASES After School Base	112,500.00	109,277.19	10,927.72
Chaparral Hills Elementary	ASES After School Base	112,500.00	109,277.19	10,927.72
Cloverdale Elementary	ASES After School Base	112,500.00	109,277.19	10,927.72
Creekside Elementary	ASES After School Base	112,500.00	109,277.19	10,927.72
Edgemont Elementary	ASES After School Base	112,500.00	109,277.19	10,927.72
Hendrick Ranch Elementary	ASES After School Base	112,500.00	109,277.19	10,927.72
Hidden Springs Elementary	ASES After School Base	112,500.00	109,277.19	10,927.72
Honey Hollow Elementary	ASES After School Base	112,500.00	109,277.19	10,927.72
La Jolla Elementary	ASES After School Base	112,500.00	109,277.19	10,927.72
Landmark Middle	ASES After School Base	150,000.00	145,702.92	14,570.29
Midland Elementary	ASES After School Base	112,500.00	109,277.19	10,927.72
Moreno Elementary	ASES After School Base	112,500.00	109,277.19	10,927.72
Mountain View Middle	ASES After School Base	150,000.00	145,702.92	14,570.29
Palm Middle	ASES After School Base	150,000.00	145,702.92	14,570.29
Ramona Elementary	ASES After School Base	112,500.00	109,277.19	10,927.72
Ridge Crest Elementary	ASES After School Base	112,500.00	109,277.19	10,927.72
Seneca Elementary	ASES After School Base	98,550.00	95,726.82	9,572.68
Serrano Elementary	ASES After School Base	112,500.00	109,277.19	10,927.72
Sugar Hill Elementary	ASES After School Base	112,500.00	109,277.19	10,927.72
Sunnymead Elementary	ASES After School Base	112,500.00	109,277.19	10,927.72
Sunnymead Middle	ASES After School Base	150,000.00	145,702.92	14,570.29
Sunnymeadows Elementary	ASES After School Base	112,500.00	109,277.19	10,927.72
TownGate Elementary	ASES After School Base	112,500.00	109,277.19	10,927.72
Avalon Elementary	ASES After School Base	112,500.00	109,277.19	10,927.72
Columbia Elementary	ASES After School Base	112,500.00	109,277.19	10,927.72
Lakeside Middle	ASES After School Base	150,000.00	145,702.92	14,570.29
Lasselle Elementary	ASES After School Base	112,500.00	109,277.19	10,927.72
Manuel L. Real Elementary	ASES After School Base	112,500.00	109,277.19	10,927.72
March Middle	ASES After School Base	150,000.00	145,702.92	14,570.29
Mary McLeod Bethune Elementary	ASES After School Base	112,500.00	109,277.19	10,927.72
May Ranch Elementary	ASES After School Base	112,500.00	109,277.19	10,927.72
Mead Valley Elementary	ASES After School Base	112,500.00	109,277.19	10,927.72
Rainbow Ridge Elementary	ASES After School Base	112,500.00	109,277.19	10,927.72
Sierra Vista Elementary	ASES After School Base	112,500.00	109,277.19	10,927.72
Tomas Rivera Middle	ASES After School Base	150,000.00	145,702.92	14,570.29
Triple Crown Elementary	ASES After School Base	112,500.00	109,277.19	10,927.72
Val Verde Elementary	ASES After School Base	112,500.00	109,277.19	10,927.72
Victoriano Elementary	ASES After School Base	112,500.00	109,277.19	10,927.72
Vista Verde Middle	ASES After School Base	68,850.00	66,877.64	6,687.76
		\$5,079,900.00	\$ 4,934,375.00	\$ 493,437.50

Schedule B
Employee Benefit Allowance

Monthly benefit allowance to be paid semi-monthly as part of employees' regular pay:

Employee	Monthly Allowance
Program Coordinator	\$1,264.58

Annual base pay ranges by position:

Current Title	THINK Title	Base Pay Range
Program Coordinator	Quality Assurance Coach	\$45,000-\$49,000

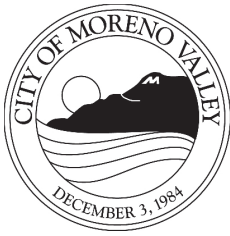

APPROVALS	
BUDGET OFFICER	<i>me</i>
CITY ATTORNEY	<i>SMB</i>
CITY MANAGER	<i>d</i>

Report to City Council

TO: Mayor and City Council, acting in their capacity as President and Board of Directors of the Moreno Valley Community Services District

FROM: Michael McCarty, Director of Parks and Community Services

AGENDA DATE: August 27, 2013

TITLE: ACCEPTANCE OF GRANT MONIES FROM THE CALIFORNIA DEPARTMENT OF EDUCATION, CHILD DEVELOPMENT SERVICES, FOR CHILD CARE SERVICES AND ADOPTION OF THE RESOLUTION TO CERTIFY THE APPROVAL OF THE GOVERNING BOARD

RECOMMENDED ACTION

Recommendations:

1. Authorize the acceptance of grant money in the amount of \$547,461 for Fiscal Year (FY) 2013/2014 from the California Department of Education, Child Development Division, for the purpose of providing school age child care and development services.
2. Adopt Resolution No. CSD 2013-16, A Resolution of the Moreno Valley Community Services District of the City of Moreno Valley, California, certifying the approval of the governing board to enter into a transaction with the California Department of Education for the purpose of providing child care and development services and to authorize the designated personnel to sign contract documents for FY 2013/2014.

BACKGROUND

The State of California appropriated a total of \$6.6 million to be utilized statewide as a continuous funding source for services to school age children, in the range of kindergarten to 14 years of age. However, the Budget Act of 2003 eliminated child care services to children 13 years and older. Of the \$6.6 million allocated statewide, Riverside County was appropriated \$950,000 based on service level needs. In an effort to provide an increased level of services for Moreno Valley youth through diverse funding, staff submitted a competitive grant application to the California Department of

Education, Child Development Division, requesting funding for a licensed after school child care program. The City of Moreno Valley Parks and Community Services Department was one of ten agencies in Riverside County who competed for this funding. The City of Moreno Valley Parks and Community Services Department was awarded funding, and “A Child’s Place” was created.

On November 26, 1996, the City Council authorized the acceptance of a grant in the amount of \$427,683 for the calendar years 1997 and 1998 for the purpose of providing an after school child care program for children ages 5 to 14 years. Since that time, the City has applied for and received grant funding every fiscal year for this program. Although the City must apply for the grant funding each year, when the funding was made available to agencies for youth programs in 1987, those agencies that have received this type of grant funding have continued to receive funding for their youth programs.

DISCUSSION

The focus of the grant submitted by the City of Moreno Valley Parks and Community Services Department was based on the high demands assessed by the Department within its own programs. This included the need for after school care during the traditional school year and full day care on school vacation days. The program utilizes five elementary schools: Creekside, Sunnymead, Rainbow Ridge, and Armada during the school year and Red Maple during school breaks. A Child’s Place is for low-income parents working or going to school and accommodates up to 142 children between the ages of kindergarten through 12 years of age.

A Child’s Place is state licensed and operates under the following conditions. The healthy social and emotional development of every child is addressed by providing activities, schedules, materials, and equipment to ensure that children are both challenged and successful. Programming for the students includes a nutritious snack served daily, arts and crafts, indoor and outdoor games, story time, homework time, and social time. The program also includes field trips with bus transportation, parent conferences, and special parenting classes and programs with topics including health issues, substance abuse, nutrition, personal safety, community awareness, literacy, and more. The program works closely with parents and school site staff to incorporate applicable school rules into the program and provide emotional support for children.

A Child’s Place operates at schools utilizing the “modified traditional” school schedule between the hours of 2:00 p.m. and 6:00 p.m. on school days and 7:00 a.m. to 6:00 p.m. on school vacation days, Monday through Friday.

As part of the City’s policy, the City Council must formally accept this funding from the California Department of Education, Child Development Services and adopt the corresponding resolution.

ALTERNATIVES

1. Authorize the acceptance of grant monies in the amount of \$547,461 for FY 2013/2014 from the California Department of Education, Child Development Division for the purpose of providing school age child care and development services; and approve the proposed resolution to certify the approval of the governing board to enter into this transaction with the California Department of Education for the purpose of providing school age child care and development services.
2. Do not accept grant funding and eliminate the Child Care Grant Program.

FISCAL IMPACT

The proposed grant funds program expenditures on a cost reimbursement basis. The grant funds as well as food program revenue and program fees are used for providing school age child care and development services and are restricted to this program. There is no impact to the General Fund. Funds are budgeted in the FY 2013-2014 Operating Budget (2201-50-58-75011).

SUMMARY

Parks and Community Services Department staff believes that continuing A Child’s Place program is in the best interest of the City. This will allow the City to continue to serve up to 142 low income students after school and during school breaks. Not only do after school programs offer constructive alternatives to gangs, drugs, and crime, but can also help improve school day attendance, increase academic achievement, and boost graduation rates.

NOTIFICATION

Posting of the agenda.

ATTACHMENTS/EXHIBITS

Attachment 1: Resolution

Prepared By:
Patty Grube
Management Analyst

Department Head Approval:
Michael McCarty
Director of Parks and Community Services

Council Action	
Approved as requested:	Referred to:
Approved as amended:	For:
Denied:	Continued until:
Other:	Hearing set for:

This page intentionally left blank.

RESOLUTION NO. CSD 2013-16

A RESOLUTION OF THE MORENO VALLEY COMMUNITY SERVICES DISTRICT OF THE CITY OF MORENO VALLEY, CALIFORNIA, CERTIFYING THE APPROVAL OF THE GOVERNING BOARD TO ENTER INTO A TRANSACTION WITH THE CALIFORNIA DEPARTMENT OF EDUCATION FOR THE PURPOSE OF PROVIDING CHILD CARE AND DEVELOPMENT SERVICES AND TO AUTHORIZE DESIGNATED PERSONNEL TO SIGN CONTRACT DOCUMENTS FOR FY 2013/14.

WHEREAS, the Moreno Valley Community Services District Board of Directors desires to provide school age child care services to the citizens of Moreno Valley during FY 2013/14;

WHEREAS, the Moreno Valley Community Services District Board of Directors further desire to enter into this transaction with the California Department of Education for the purpose of providing child care and development services; and

WHEREAS, the Moreno Valley Community Services District Board of Directors authorize the persons listed to sign the transaction for the Governing Board.

Michael McCarty, Director of Parks and Community Services _____

Mel Alonzo, Parks and Community Services Division Mgr _____

Richard Teichert, Chief Financial Officer _____

NOW, THEREFORE, THE MORENO VALLEY COMMUNITY SERVICES DISTRICT OF THE CITY OF MORENO VALLEY, CALIFORNIA, DOES HEREBY RESOLVE AS FOLLOWS:

1. Accept the grant monies from the California Department of Education, Child Development Division, in the amount of \$547,461 per fiscal year to provide child care services for FY 2013/2014;
2. Adopt a resolution to certify the approval of the governing board to enter into local agreement number/s CCTR-3173, Project Number 33-2186-00-3 with the California Department of Education for the purpose of providing child care and development services;
3. Authorize designated personnel to sign contract documents on behalf of the Governing Board for FY 2013/14.

1
Resolution No. CSD 2013-16
Date Adopted: August 27, 2013

APPROVED AND ADOPTED this 27th day of August, 2013.

Mayor of the City of Moreno Valley,
acting in the capacity of President
of the Moreno Valley Community
Services District

ATTEST:

Jane Halstead, acting in the capacity of
Secretary of the Moreno Valley
Community Services District

APPROVED AS TO FORM:

Suzanne Bryant, City Attorney acting
in the capacity of General Legal
Counsel of the Moreno Valley
Community Services District

Resolution No. CSD 2013-16²
Date Adopted: August 27, 2013

RESOLUTION JURAT

STATE OF CALIFORNIA)
COUNTY OF RIVERSIDE) ss.
CITY OF MORENO VALLEY)

I, Jane Halstead, Secretary of the Moreno Valley Community Services District, Moreno Valley, California do hereby certify that Resolution No. CSD 2013-16 was duly and regularly adopted by the Board of Directors of the Moreno Valley Community Services District at a regular meeting held on the 27th day of August, 2013, by the following vote:

AYES:

NOES:

ABSENT:

ABSTAIN:

(Boardmembers, Vice-President and President)

SECRETARY

(SEAL)

3
Resolution No. CSD 2013-16
Date Adopted: August 27, 2013

This page intentionally left blank.

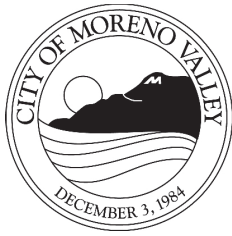

APPROVALS	
BUDGET OFFICER	<i>me</i>
CITY ATTORNEY	<i>SMB</i>
CITY MANAGER	<i>d</i>

Report to City Council

TO: Mayor and City Council, acting in its capacity as President and Members of the Board of Directors of the Moreno Valley Community Services District

FROM: Richard Teichert, Chief Financial Officer

AGENDA DATE: August 27, 2013

TITLE: SECOND EXTENSION OF THE AGREEMENT – PROJECT NO. 2011 TREE TRIM/REMOVAL MAINTENANCE

RECOMMENDED ACTION

Recommendations:

1. Approve the Second Extension of the Agreement (“Second Extension Agreement”) for Project No. 2011, Tree Trim/Removal Services, with West Coast Arborists, Inc., 2200 E. Burton Street, Anaheim, CA 92806 for tree trimming and removal services within Community Services District (CSD) zones D, E-1, E-1A, E-2, E-3, E-4, E-7, E-8, E-12, E-14, E-15, E-16, M and S.
2. Authorize the City Manager to execute the Second Extension Agreement for tree trimming/removal services with West Coast Arborists, Inc.
3. Authorize the issuance of a purchase order for services beginning September 1, 2013 to West Coast Arborists, Inc., in the not-to-exceed (NTE) amount of \$97,050.00. This amount includes \$82,705.00 for base and \$14,345.00 for additional work.
4. Authorize the City Manager to execute subsequent Extensions or Amendments to the Agreement, within Council approved annual budgeted amounts, including the authority to authorize the associated purchase order (P.O.) in accordance with the terms of the Agreement, subject to the approval of the City Attorney.

ADVISORY BOARD/COMMISSION RECOMMENDATION

N/A

BACKGROUND

The Moreno Valley Community Services District (CSD) furnishes parkway, median and open space landscape maintenance services to designated tracts and developments. CSD landscape maintenance areas include:

Zone D (landscape maintenance) services to non-specific plan tracts, which are provided at either a standard or reduced level of landscape maintenance services.

Zone E (extensive landscape maintenance), provides landscape maintenance services at standard or reduced service levels, for the parkways, medians, and landscaped open space areas of specific plan developments. Zone E areas include: E-1 (Towngate), E-1A (Renaissance Park), E-2 (Hidden Springs), E-3 (Moreno Valley Ranch-West), E-3A (Lasselle Powerline Parkway), E-4 (Moreno Valley Ranch-East), E-4A (Daybreak), E-7 (Centerpointe), E-8 (Promontory Park), E-12 (Stoneridge Ranch), E-14 (Mahogany Fields), E-15 (Celebration), and E-16 (Shadow Mountain).

Zone M (Commercial, Industrial, and/or Multifamily Improved Median Maintenance), provides landscape maintenance of certain landscaped median areas citywide.

Zone S (Sunnymead Boulevard) provides median and parkway landscape maintenance to certain improvements along Sunnymead Boulevard.

Maintenance provided to the landscaped CSD zones is performed via contract services by professionally licensed and insured contractors that perform landscape or specialty maintenance services. Landscape and landscape related specialty service agreements are awarded through a competitive Request for Proposal (RFP) process and entered into via an Independent Contractor Agreement. In accordance with the terms of the Agreement, annual extensions of the Agreement may be entered into up to no more than 4 extensions of the original Agreement, based on services being sufficiently performed at or better than the specifications as outlined in the Agreement, with concurrence of both the CSD and Contractor, at the base rate as provided in the Agreement, plus an additional amount for extra or unanticipated work that may be performed during the term of the Agreement or any applicable Extension Agreement.

The not-to-exceed (NTE) amount of the Agreement or Extension Agreement includes an amount for base services and an amount for unanticipated additional work.

“Base services” for tree trimming or removal includes: trimming/pruning or removal of identified trees within designated CSD zones, litter and debris pick-up and disposal, and recycling of greenwaste materials in accordance with federal, state, and local codes. Base services are performed on identified trees within designated CSD zones, contingent upon available program funding.

“Additional work” includes, but is not necessarily limited to, additional labor and/or material costs to trim/prune or remove additional trees that may be required as a result of emergency or hazardous conditions at the unit prices for additional work as specified in the Agreement.

DISCUSSION

On October 17, 2011, the Special Districts Division of the Financial and Management Services Department received proposals from two (2) tree maintenance companies in response to a Request for Proposal (RFP) to provide tree trimming and/or removal services of trees within the CSD zones. On November 15, 2011 upon staff’s evaluation of the proposals and recommendation, the City Manager, acting in the capacity as District Manager to the Board of Directors of the Moreno Valley CSD, with approval as to legal form by the City Attorney, awarded the contract for tree trimming and removal services to West Coast Arborists, Inc., Anaheim, California (the “Contractor”). The amount of the Agreement for the initial contracting term, fiscal year (FY) 2011/12, was \$93,220.00, all of which was designated for base services.

On October 3, 2012, a First Extension Agreement was approved for FY 2012/13 by the City Manager, acting in the capacity as District Manager to the CSD Board, with approval as to legal form by the City Attorney. The Agreement for tree trimming and/or removal services for the CSD zones had a combined base amount of \$75,005.00 and a combined additional work amount of \$7,445.00 for a NTE Agreement amount of \$82,450.00.

The tree trimming and/or removal services have been consistently and satisfactorily performed by the Contractor in accordance with the terms of both the Agreement and the First Extension Agreement, and the Contractor has agreed to further extend the Agreement based upon the same rates and terms of the Agreement as first extended and as identified in this Second Extension Agreement.

Approval of the Extension Agreement for Fiscal Year 2013/14

Approval of the Second Extension Agreement is recommended for authorization in the NTE amount of \$97,050.00 for FY 2013/14. This amount includes \$82,705.00 for base trimming/removal services and an additional work amount of \$14,345.00. This is the second of four possible extensions allowed per the terms of the Agreement.

Authority for City Manager Approval of Extension Agreements for the Balance of Available Extensions to the Agreement

Pursuant to City Council Resolution No. 2008-115, the City Council shall provide approval of procurements greater than \$100,000. Because the current Procurement Policy (Policy #3.18, Section V.B.3) allows the original agreement to be extended for four additional one-year terms, the total potential value of the Agreement is being taken into consideration when determining signature authority. The following table shows a cumulative overview of the costs for the Tree Trim/Removal Agreement, as may be allowed per the terms of the Agreement. Potential extensions are those extensions

which may be allowed, contingent upon satisfactory service by the Contractor and concurrence by the CSD and Contractor to enter into an extension of the Agreement, or the Agreement as Amended.

Project No. 2011 - Tree Trimming / Removal Services						
	FY 2011/12 Original Agreement	FY 2012/13 First Extension ¹	FY 2013/14 Proposed Second Extension ¹	FY 2014/15 Potential Third Extension ²	FY 2015/16 Potential Fourth Extension ²	Cumulative Total
Base	\$ 93,220.00	\$ 75,005.00	\$ 82,705.00	\$ 82,705.00	\$ 82,705.00	\$ 416,340.00
Additional Work	\$ -	\$ 7,445.00	\$ 14,345.00	\$ 14,345.00	\$ 14,345.00	\$ 50,480.00
Total	\$ 93,220.00	\$ 82,450.00	\$ 97,050.00	\$ 97,050.00	\$ 97,050.00	\$ 466,820.00

¹ The First and Proposed Second Extensions include the costs for trimming/removal of identified trees (base) cost and an additional work amount for trimming or removals due to unanticipated Health and Safety issues.

² Extensions beyond 2013/14 are anticipated costs based upon presently known information.

Staff is requesting the City Council, in its capacity as the CSD Board, authorize the City Manager to approve extensions and any necessary amendments, as well as associated purchase orders for all remaining extensions available, in accordance with the terms of the Agreement, subject to the approval of the City Attorney. Such extensions and amendments shall only be entered into upon determination that sufficient funding appropriations and program approvals have been granted by the City Council (CSD Board), demonstration by the Contractor of having satisfactorily performed services, per the terms of the Agreement in the prior year(s) and both the CSD and the Contractor mutually agreeing to extend the Agreement.

ALTERNATIVES

1. Approve the Second Extension Agreement for Project No. 2011 Tree Trim/Removal Services, with West Coast Arborists, Inc., in the form attached hereto for tree trimming and removal services within the CSD zones; authorize the City Manager to execute said Second Extension Agreement for Project No. 2011 Tree Trim/Removal Services, with West Coast Arborists, Inc.; authorize issuance of purchase orders for FY 2013/14 in the NTE amount of \$97,050.00 (\$82,705.00 for base trimming/removal services and \$14,345.00 for additional work) as designated for the various CSD zones; and authorize the City Manager to execute subsequent Extensions or Amendments to the Agreement and authorize the associated purchase orders as may be required in accordance with the terms of the Agreement, subject to the approval of the City Attorney. *By selecting this alternative the CSD Board will allow for necessary tree trimming and removal services of identified trees within the various CSD zones.*
2. Do not approve the Second Extension Agreement for Project No. 2011 Tree Trim/Removal Services, with West Coast Arborists, Inc., in the form attached hereto for tree trimming and removal services within the CSD zones; nor authorize the City Manager to execute said Second Extension Agreement for Project No. 2011 Tree Trim/Removal Services, with West Coast Arborists, Inc.; nor authorize issuance of

purchase orders for FY 2013/14 in the NTE amount of \$97,050.00 (\$82,705.00 for base trimming/removal services and \$14,345.00 for additional work) as designated for each CSD zone; and do not authorize the City Manager to execute subsequent Extensions or Amendments to the Agreement nor authorize the associated purchase orders as may be required in accordance with the terms of the Agreement, subject to the approval of the City Attorney. *By selecting this alternative tree trimming and removal services will be delayed, which in turn may cause an increase in the cost of providing the service and could interfere with the migratory bird nesting season, which for Southern California generally runs each year from January 15 to August 31, as advised by staff from the U.S. Fish and Wildlife Services.*

FISCAL IMPACT

Administration and maintenance of the CSD zones D, E, M and S are funded through a property owner approved parcel charge, which is levied and collected on the property tax bills. Revenue from the parcel charges collected for each of the CSD zones may only be used for landscape maintenance services, which includes tree trimming and removal services, associated with the parkways and medians in these CSD zones. **The costs for these maintenance services have been budgeted, respectively, for each of these CSD zones for the current fiscal year. These actions will not impact the City's General Fund.**

The following table represents the base and additional work costs for FY 2013/14 associated with the Second Extension Agreement for each of the listed CSD zones.

Service Area (Zone) ¹	Contractor	GL Account	2013/14 Base Agreement Amount	2013/14 Additional Work Agreement Amount	2013/14 Total Agreement Amount
D	West Coast Arborists, Inc.	5111-30-79-25704-620910	\$ 18,830.00	\$ 1,545.00	\$ 20,375.00
E-1	West Coast Arborists, Inc.	5013-30-79-25706-620910	5,250.00	750.00	6,000.00
E-1A	West Coast Arborists, Inc.	5013-30-79-25707-620910	-	500.00	500.00
E-2	West Coast Arborists, Inc.	5013-30-79-25708-620910	16,730.00	2,000.00	18,730.00
E-3	West Coast Arborists, Inc.	5013-30-79-25709-620910	15,995.00	2,000.00	17,995.00
E-4	West Coast Arborists, Inc.	5013-30-79-25711-620910	15,505.00	495.00	16,000.00
E-7	West Coast Arborists, Inc.	5013-30-79-25713-620910	3,360.00	640.00	4,000.00
E-8	West Coast Arborists, Inc.	5013-30-79-25714-620910	1,120.00	1,680.00	2,800.00
E-12	West Coast Arborists, Inc.	5013-30-79-25715-620910	1,855.00	1,145.00	3,000.00
E-14	West Coast Arborists, Inc.	5013-30-79-25716-620910	-	750.00	750.00
E-15	West Coast Arborists, Inc.	5013-30-79-25717-620910	1,750.00	500.00	2,250.00
E-16	West Coast Arborists, Inc.	5013-30-79-25718-620910	-	850.00	850.00
M	West Coast Arborists, Inc.	5112-30-79-25719-620910	2,310.00	490.00	2,800.00
S	West Coast Arborists, Inc.	5114-30-79-25720-620910	-	1,000.00	1,000.00
Total			\$ 82,705.00	\$ 14,345.00	\$ 97,050.00

¹ No trees are identified for trimming/removal (base) in E-1A, E-14, E-16, and S. An additional work amount for E-1A, E-14, E-16 and S is being allocated in the event of an unanticipated Health and Safety issue(s) is identified.

CITY COUNCIL GOALS

Public Safety and Community Image and Positive Environment:

The City Council in their capacity as the CSD Board will allow for necessary maintenance of the parkway trees within CSD landscaped parkways, medians and open areas be performed in a safe manner, in accordance with State and Federal regulations, and consistent with approved landscape maintenance program funding, which will help to promote community image and pride.

NOTIFICATION

N/A

ATTACHMENTS

Attachment 1: Second Extension Agreement for Tree Trimming/Removal Services for FY 2013/14

Attachment 2: First Extension Agreement for Tree Trimming/Removal Services for FY 2012/13

Attachment 3: Agreement for Tree Trimming/Removal Services for FY 2011/12

Prepared By:
Sharon Sharp
Senior Management Analyst

Department Head Approval:
Richard Teichert
Chief Financial Officer

Concurred By:
Candace Cassel
Special Districts Division Manager

Council Action	
Approved as requested:	Referred to:
Approved as amended:	For:
Denied:	Continued until:
Other:	Hearing set for:

SECOND EXTENSION AGREEMENT
PROJECT NO. 2011 TREE TRIM/REMOVAL
MAINTENANCE OF PARKWAY AND MEDIAN
LANDSCAPING AND IRRIGATION

THIS AGREEMENT is made and entered into by and between the Moreno Valley Community Services District (“District”) and **West Coast Arborists, Inc.** (“Contractor”).

WHEREAS, the District and Contractor entered into an Independent Contractor Agreement, (hereinafter referred to as “Agreement”), dated November 15, 2011 referencing Project No. 2011 Tree Trim/Removal for the purpose of providing tree trimming and removal services of designated trees within various District parkway and median landscaped areas throughout the City of Moreno Valley; and,

WHEREAS, during the initial term of the Agreement tree trimming and removal services were sufficiently performed, and both District and Contractor mutually agreed to enter into an extension of the Agreement (First Extension Agreement) for the term of July 1, 2012 to June 30, 2013; and,

WHEREAS, tree trimming and removal services provided during the term of the First Extension Agreement were sufficiently performed; and,

WHEREAS, pursuant to the terms of the Agreement, both parties wish to enter into a second extension of the Agreement (Second Extension Agreement) for a period of twelve (12) months under the following terms:

1. The extension period shall commence on **July 1, 2013** and shall terminate on **June 30, 2014**.
2. In accordance with Exhibit D. 1. B. of the Agreement, this Extension shall be considered the second of four possible extensions of the Agreement.
3. For the period of this Second Extension Agreement and except where additional compensation is specifically provided for in the Agreement, the District will pay the Contractor for all work (labor, materials, supplies, equipment, etc.) for the performance of tree trimming/removal services of those trees as identified on Attachment 1-A of this Second Extension Agreement, as incorporated herein by this statement and, consistent with the terms of the Agreement, pay to the Contractor a fee of **\$35.00 per trim** and **\$175.00 per removal** of those trees as listed on Attachment 1 of this Second Extension Agreement. Payment shall be made on a per month basis, one month in arrears, on the last day of the month based upon the total number of trees trimmed and/or removed for the preceding month at the rates stated herein this Second Extension Agreement. The total amount of this Second Extension Agreement for the twelve (12) month extension period shall not exceed **EIGHTY-TWO THOUSAND SEVEN HUNDRED FIVE AND 00/100 DOLLARS (\$82,705.00)** to trim or remove the quantity of trees identified in Attachment 1.

SECOND EXTENSION AGREEMENT
PROJECT NO. RFP NO. 2011 TREE TRIM/REMOVAL
PARKWAY AND MEDIAN
TREE TRIMMING AND REMOVAL

4. Except as provided for in Section 3 herein, the unit prices as set forth in the Additional Work Price List on Exhibit E, Schedule II, Section II on page 65 of the Agreement, shall apply for any additional trees not included herein, which may be added to the project during the term of this Extension Agreement.
5. Notwithstanding Exhibit C. 2 A., of the Agreement, for the period of this Extension and except as specifically approved by subsequent action of the CSD Board (City Council), the Director (the Chief Financial Officer/City Treasurer or their designated appointee) may not authorize additional work pursuant to this Extension in excess of the cumulative total of **FOURTEEN THOUSAND THREE HUNDRED FORTY-FIVE AND 00/100 DOLLARS (\$14,345.00)**.
6. Except as set forth herein, all other terms and conditions of the Agreement shall remain in full force and effect.

SIGNATURE PAGE FOLLOWS

SECOND EXTENSION AGREEMENT
PROJECT NO. RFP NO. 2011 TREE TRIM/REMOVAL
PARKWAY AND MEDIAN
TREE TRIMMING AND REMOVAL

IN WITNESS HEREOF, the parties have each caused their authorized representative to execute this Agreement

Moreno Valley
Community Services District

Contractor: West Coast Arborists, Inc.

By: _____
Title: City Manager, Acting in the capacity of
District Manager to the Moreno Valley
Community Services District

By: _____
Title: (President or Vice President)

Date: _____

Date: _____

<u>INTERNAL USE ONLY</u>
ATTEST:
_____ City Clerk
APPROVED AS TO LEGAL FORM:
_____ City Attorney
_____ Date
RECOMMENDED FOR APPROVAL:
_____ Department Head
_____ Date

By: _____
Title: Corporate Secretary or Assistant
Secretary

Date: _____
Affix Corporate Seal Below

Zone	Street Section	Tree Species	Work to be Performed Trim or Removal	No of Trees to be Trimmed	No of Trees to be Removed	
E-2 Hidden Springs (Cont.)	Paseo area behind homes facing Sycamore Canyon Rd. (near mulch pile)	Pepper	Trim	9	0	
	Paseo area behind homes facing Sycamore Canyon Rd. (near mulch pile)	Oak	Trim	4	0	
	S/s Sycamore Canyon Rd., and Waterfall Ct.	Pepper	Trim	4	0	
	Waterfall Ct. cul de sac	Pepper	Trim	4	0	
	Paseo entrance on Sycamore Canyon Rd. and Lakeside Dr.	Tipawanna	Trim	4	0	
	On south slope, behind houses on Mt. View Rd.	Various	Trim	120	0	
	Throughout Paseo	Various	Removal	0	18	
	Total (E-2)			348	26	
	E-3 MV Ranch - West	E/s of Kitching St., from Camino Marilena to Krameria Ave.	Acacia	Trim	1	0
		E/s of Kitching St., from Krameria Ave. to Iris Ave.	Acacia	Trim	13	0
E/s of Kitching St., from Iris Ave. to Gentian Ave.		Pine	Trim	7	0	
E/s of Kitching St., from Iris Ave. to Gentian Ave.		Acacia	Trim	10	0	
S/s of Gentian Ave. from Kitching St. to Lasselle St.		Acacia	Trim	4	0	
S/w corner from Lasselle St. to Gentian Ave.		Pepper	Trim	1	0	
S/e corner from Lasselle St. and Gentian Ave.		Pepper	Trim	1	0	
W/s of Lasselle St. from Gentian Ave. to Iris Ave.		Pine	Trim	9	0	
E/s of Lasselle St. from Gentian Ave. to Iris Ave.		Pine	Trim	7	0	
E/s of Lasselle St. from Gentian Ave. to Iris Ave.		Palm	Trim	7	0	
E/s of Lasselle St. from Gentian Ave. to the school		Pine	Trim	32	0	
N/s of Iris Ave. from Los Cabos Dr. to Kitching St.		Pine	Trim	31	0	
N/s of Iris Ave. from La Fortuna Ln. to Kitching St.		Palm	Trim	8	0	
S/s of Iris Ave. from La Fortuna Ln. to Kitching St.		Palm	Trim	8	0	
S/s of Iris Ave. from Kitching St. to Lasselle St.		Pine	Trim	24	0	
W/s of Grande Vista Dr. from Iris Ave. to the top of the hill		Acacia	Trim	8	0	
E/s of Grande Vista Dr. from Iris Ave. to the top of the hill		Acacia	Trim	8	0	
N/s of Iris Ave. at the flood channel		Eucalyptus	Removal	0	1	
N/s of Iris Ave, at both corners of Ponderosa St.		Pepper	Trim	2	0	
S/w corner of Iris Ave. and Lasselle St.		Pepper	Trim	1	0	
S/w corner of Iris Ave. and Lasselle St.	Palm	Trim	8	0		
S/e corner of Iris Ave. and Lasselle St.	Pepper	Trim	1	0		
S/e corner of Iris Ave. and Lasselle St.	Palm	Trim	8	0		
N/e corner of Iris Ave. and Lasselle St.	Palm	Trim	3	0		
N/w corner of Iris Ave. and Lasselle St.	Palm	Trim	11	0		
N/e corner of Iris Ave. and Kitching St.	Pepper	Trim	1	0		
S/e corner of Iris Ave. and Kitching St.	Pepper	Trim	1	0		
W/s of Lasselle St. from Iris Ave. to Krameria Ave.	Pine	Trim	53	0		
W/s of Lasselle St. from Krameria Ave. to Arroyo Park	Pine	Trim	76	0		

Item No. B.6

Item No.	Street Section	Tree Species	Work to be Performed Trim or Removal	No of Trees to be Trimmed	No of Trees to be Removed
<p>³ MV Ranch - West (1t.)</p>	<p>W/s of Lasselle St. from Avenida De Plata to Camino Del Rey E/s of Lasselle St. from Kentucky Derby Dr. to Cremello Way S/e corner of Krameria Ave. and Kitching St. N/e corner of Krameria Ave. and Kitching St. Miscellaneous Removals throughout E-3</p>	<p>Pine Pine Palm Palm Various</p>	<p>Trim Trim Trim Trim Removal</p>	<p>15 6 6 6 0 377</p>	<p>0 0 0 0 15 16</p>
<p>E-4 MV Ranch - East</p>	<p>Total (E-3)</p> <p>W/s of John F. Kennedy Dr. from Cactus Ave. to Moreno Beach Dr. W/s of John F. Kennedy Dr. from Cactus Ave. to Moreno Beach Dr. N/s of Moreno Beach Dr. from John F. Kennedy Dr. to Oliver Ave. N/s of Moreno Beach Dr. from John F. Kennedy Dr. to Oliver Ave. E/s of Oliver Ave. from Moreno Beach Dr. to John F. Kennedy Dr. E/s of Oliver Ave. from Moreno Beach Dr. to John F. Kennedy Dr. S/s of John F. Kennedy Dr. from Legendary Dr. to Entrance Miscellaneous Removals throughout E-4</p>	<p>Sycamore Oak Sycamore Pepper Oak Pepper Sycamore Variou</p>	<p>Trim Trim Trim Trim Trim Trim Trim Removal</p>	<p>133 45 77 38 20 9 21 0 343</p>	<p>0 0 0 0 0 0 0 20 20</p>
<p>E-7 Centerpointe</p>	<p>Total (E-4)</p> <p>W/s of Frederick St. from Alessandro Blvd. to Cactus Ave. S/w corner of Alessandro Blvd. and Frederick St. S/w corner of Alessandro Blvd. and Frederick St. S/e corner of Alessandro Blvd. and Frederick St. S/e corner of Alessandro Blvd. and Frederick St. N/w corner of Cactus Ave. and Frederick St. N/w corner of Cactus Ave. and Frederick St. N/e corner of Cactus Ave. and Frederick St. N/e corner of Cactus Ave. and Frederick St. W/s of Frederick St. from Cactus Ave. to Alessandro Blvd.</p>	<p>Crape Myrtle Pepper Palm Pepper Palm Pepper Palm Crape Myrtle</p>	<p>Trim Trim Trim Trim Trim Trim Trim Trim</p>	<p>35 4 3 4 4 4 5 4 5 28 96</p>	<p>0 0 0 0 0 0 0 0 0 0 0</p>
<p>E-8 Promontory Park</p>	<p>Total (E-7)</p> <p>Cactus Ave., between Dusty Coyote Ave. to the E/s of Oliver Ave.</p>	<p>African Sumac</p>	<p>Trim</p>	<p>32 32</p>	<p>0 0</p>
<p>E-12 Stoneridge Ranch</p>	<p>Total (E-8)</p> <p>Nason St., from Dracaea Ave. to Fir Ave. on the E/s</p>	<p>Camphor</p>	<p>Trim</p>	<p>53 53</p>	<p>0 0</p>

Zone	Street Section	Tree Species	Work to be Performed Trim or Removal	No of Trees to be Trimmed	No of Trees to be Removed
E-15 Celebration	Nason St. between Damascus Rd. / Delphinium Ave. & Cactus Ave., W/o Oliver Ave.	Palo Verde	Trim	12	0
	Nason St. between Damascus Rd. / Delphinium Ave. & Cactus Ave., W/o Oliver Ave.	African Sumac	Trim	23	0
	Nason St. between Damascus Rd. / Delphinium Ave. & Cactus Ave., W/o Oliver Ave.	African Sumac	Removal	0	3
	Total (E-15)			35	3
D Tracts	Ironwood Ave. W/o Box Springs Rd.	California Pepper	Trim	13	0
	John F. Kennedy Dr. & Lasselle St. / Kitching St.	Liquid Ambar	Removal	0	5
	Lasselle St. & Lancia St. (W/o Lasselle St.)	Palm	Trim	10	0
	Iris Ave. & Perris Blvd.	Sycamore	Removal	0	1
	Eucalyptus Ave., N/s between Lasselle St. & Sample Ct.	Eucalyptus	Trim	14	0
	Locust Ave. & Twilight Way	Acacia	Trim	9	0
	Locust Ave. & Twilight Way	Acacia	Removal	0	3
	S/s of John F. Kennedy Dr., W/o Perris Blvd.	Bottle Tree	Removal	0	5
	John F. Kennedy Dr. & Lasselle St. / Kitching St.	Liquid Ambar	Removal	0	6
	Alessandro Ave. from Covey Quail Ln. to Indian St.	Palm	Trim	8	0
	Kitching St. & Dracaea Ave., W/s	Liquid Ambar	Removal	0	5
	Cottonwood Ave. & Grape Myrtle Dr. to Kitching St. & Alessandro Blvd.	Liquid Ambar	Removal	0	8
	Eucalyptus Ave. from Adeline Ave. to Tierra Canyon	Camphor	Trim	10	0
	Kitching St. & Iris Ave. (W/s)	Pine	Trim	16	0
	Kitching St. & Iris Ave. (W/s)	Eucalyptus	Trim	6	0
	Kitching St. & Iris Ave. (W/s)	Eucalyptus	Removal	0	2
	E/s Indian St., between Bay Ave. & Indian St.	Camphors	Trim	19	0
	S/s of John F. Kennedy Dr., W/o Perris Blvd.	Liquid Ambar	Removal	0	1
	Kitching St. & Moorland Rd. to Karmeria Ave. & Perris Blvd.	Oak	Trim	20	0
	Lasselle St. & Bay Ave. (E/s of Lasselle St.)	Palm	Trim	22	0
	Lasselle St. & Bay Ave. (E/s of Lasselle St.)	Bottle Tree	Trim	3	0
	Ironwood Ave. E/o Day St.	Liquid Ambar	Removal	0	4
	Ironwood Ave. E/o Day St.	Acacia	Trim	1	0
	Ironwood Ave. & Barcly Dr.	Eucalyptus	Removal	0	5
	Cactus Ave. & Lasselle St.	Liquid Ambar	Removal	0	2
	Fir Ave. & Elmhurst Dr.	Liquid Ambar	Removal	0	4
	Kitching St. & Atwood Ave., also Kitching St. & Eucalyptus Ave.	Plum	Removal	0	3
Kitching St. & Atwood Ave., also Kitching St. & Eucalyptus Ave.	Plum	Removal	0	4	
Nason St., between Dracaea Ave. /Cottonwood Ave./ Athletics Dr. & Letterman St.	Palo Verdes	Trim	24	0	
Nason St., between Dracaea Ave. /Cottonwood Ave./ Athletics Dr. & Letterman St.	Camphors	Trim	50	0	
Redlands Blvd. & Cottonwood Ave.	African Sumac	Trim	12	0	
Redlands Blvd. & Cottonwood Ave.	Chinese Pastiche	Trim	11	0	
	Total (D)		248	58	

Item No. B.6

Item No.	Street Section	Tree Species	Work to be Performed Trim or Removal	No of Trees to be Trimmed	No of Trees to be Removed
3 Medians	Alessandro Blvd. monuments & Old Highway 215 Alessandro Blvd. from Old Highway 215 to Day St. Alessandro Blvd. from Day St. to Elsworth Ave. Alessandro Blvd. from Elsworth Ave. to Frederick St. Alessandro Blvd. from Frederick St. to Graham Ave. Alessandro Blvd. west of Graham Ave.	Jacaranda Various Various Various Various Liquid Ambar	Trim Trim Trim Trim Trim Removal	6 10 16 14 15 0	0 0 0 0 0 1 1
	Total (M - Medians)			1,743	124
	Grand Total			1,743	124

**FIRST EXTENSION AGREEMENT
PROJECT NO. 2011 TREE TRIM/REVOAL
MAINTENANCE OF PARKWAY AND MEDIAN
LANDSCAPING AND IRRIGATION**

THIS AGREEMENT is made and entered into by and between the Moreno Valley Community Services District (hereafter, "District") and **West Coast Arborists, Inc.** (hereafter, "Contractor")

WHEREAS, the District and Contractor entered into an independent contractor agreement, hereinafter referred to as "Agreement", dated November 15, 2011 referencing Project No. 2011 Tree Trim/Removal for the purpose of providing tree trimming and removal of designated trees within various District parkway and median landscaped areas throughout the City of Moreno Valley.

WHEREAS, pursuant to the terms of the Agreement, both parties wish to extend the Agreement.

WHEREAS, the Extension of the Agreement shall be extended for a period of twelve (12) months under the following terms:

1. The extension period shall commence on **July 1, 2012** and shall terminate on **June 30, 2013**.
2. In accordance with Exhibit D, Section 1.B. of the Agreement, this Extension shall be considered the first of four possible extensions of the Agreement.
3. For the period of this Extension and except where additional compensation is specifically provided for in the Agreement, the District will pay the Contractor for all work (labor, materials, supplies, equipment, etc.) for the performance of tree trimming/removal services of those trees as identified on Attachment 1 of this Extension Agreement, and incorporated herein by this statement and shall, consistent with the terms of the Agreement, pay to the Contractor a fee of **\$35.00 per trim and \$175.00 per removal** of those trees listed on Attachment 1 of this Extension Agreement. Payment shall be made per month, one month in arrears, on the last day of the month based upon the total number of trees trimmed and/or removed for the preceding month at the rates stated herein this Extension Agreement. The total amount of this Extension Agreement for the twelve (12) month extension period shall not exceed **SEVENTY FIVE THOUSAND AND FIVE AND 00/100 DOLLARS (\$75,005.00)**.
4. Except as provided for in Section 3 herein, the unit prices as set forth in the Additional Work Price List on Exhibit E, Schedule II, Section II on page 65 of the Agreement, shall apply for any additional trees not included herein which may be added to the project during the period of this Extension Agreement.

EXTENSION AGREEMENT
PROJECT NO. RFP NO. 2011 TREE TRIM/REMOVAL
PARKWAY AND MEDIAN
TREE TRIMMING AND REMOVAL

5. Notwithstanding Exhibit C., Numeral 2, Letter A, of the Agreement, for the period of this Extension and except as specifically approved by subsequent action of the CSD Board (City Council), the Director (the Public Works Director/City Engineer or his designated appointee) may not authorize additional work pursuant to this Extension in excess of the cumulative total of **SEVEN THOUSAND FOUR HUNDRED FORTY-FIVE AND 00/100 DOLLARS (\$7,445.00)**.
6. Except as set forth herein, all other terms and conditions of the Agreement shall remain in full force and effect.

SIGNATURE PAGE FOLLOWS

EXTENSION AGREEMENT
PROJECT NO. RFP NO. 2011 TREE TRIM/REMOVAL
PARKWAY AND MEDIAN
TREE TRIMMING AND REMOVAL

IN WITNESS HEREOF, the parties have each caused their authorized representative to execute this Agreement

Moreno Valley
Community Services District

Contractor: West Coast Arborists, Inc.

By: *Michelle Dawson*
Title: City Manager, Acting in the capacity of
District Manager to the Moreno Valley
Community Services District

By: *[Signature]* Patrick Mahoney
Title: President

Date: 10/3/12

Date: September 20, 2012

INTERNAL USE ONLY

ATTEST:

City Clerk

APPROVED AS TO LEGAL FORM:

[Signature]
Deputy City Attorney

10-1-12
Date

RECOMMENDED FOR APPROVAL:

[Signature]
Department Head

10/2/12
Date

By: *[Signature]* Richard Mahoney
Title: Assistant Secretary

Date: September 20, 2012
Affix Corporate Seal Below

Zone	Street Section	Tree Species	Work to be Performed Trim or Removal	No of Trees to be Trimmed	No of Trees to be Removed
E- 1 TownGate	Frederick Medians, South of Sunnymead Boulevard	Pine	Trim	6	0
	N/s Eucalyptus Ave., from Frederick to Towngate	Sumac	Trim	26	0
	N/s Eucalyptus Ave., from Frederick to Towngate	Liquid Ambar	Trim	10	0
	S/s Eucalyptus Ave., from Towngate to Stanhope	Sumac	Trim	7	0
	S/s Eucalyptus Ave., from Towngate to Stanhope	Liquid Ambar	Trim	1	0
	S/s Eucalyptus Ave., from Towngate to Stanhope	Crape Myrtle	Trim	3	0
	Towngate Medians, from Frederick to Memorial	Brazilian Pepper	Trim	18	0
	Towngate Medians, from Frederick to Memorial	Crape Myrtle	Trim	1	0
	N/s Dracaea Ave., from Brentwood to Elsworth	Pine	Trim	29	0
	E/s Elsworth Ave. from Dracea to Eucalyptus	Pine	Tim	30	0
	Total (E-1)				131
E- 1 A TownGate	S/s Dracea from Arbor Park to Elsworth	Eucalyptus	Trim	12	0
	E/s Arbor Park from Dracea to Eucalyptus	Fern Pine	Trim	3	0
	E/s Arbor Park from Dracea to Eucalyptus	Liquid Ambar	Trim	3	0
	W/s Arbor Park from Eucalyptus to Dracea	Liquid Ambar	Trim	6	0
	W/s Arbor Park from Eucalyptus to Dracea	Camphor	Trim	9	0
	W/s Arbor Park from Eucalyptus to Dracea	Fern Pine	Trim	4	0
	Dracaea from Arbor Park to Day	Eucalyptus	Trim	5	0
	Total (E-1A)				42
E- 2 Hidden Springs	Corner of Sycamore Canyon and Hidden Springs	Oak	Trim	6	0
	E/s of Hidden Springs from Sycamore Canyon to Mesa Springs	Pine	Trim	16	0
	E/s Hidden Springs, from Mesa Springs to Shadow Ridge	Pine	Trim	12	0
	E/s Hidden Springs, from Shadow Ridge to Mountain View	Pine	Trim	17	0
	E/s Hidden Springs, from Shadow Ridge to Mountain View	Tipawanna	Remove	0	1
	E/s Hidden Springs from Mountain Viw to Country Gate	Bottle	Trim	7	0
	E/s corners of Hidden Springs and Country Gate	Camphor	Trim	4	0
	E/s corners of Hidden Springs and Country Gate	Tipawanna	Trim	2	0
	E/s Hidden Spings from Country Gate to Mountain View	Bottle	Trim	31	0
	E/s Hidden Spings from Country Gate to Mountain View	Tipawanna	Trim	2	0
	E/s Hidden Spings from Country Gate to Mountain View	Alder	Trim	2	0
	E/s Hidden Springs from Mountin View to Pigeon Pass	Pine	Trim	1	0
	E/s Hidden Springs from Mountin View to Pigeon Pass	Bottle	Trim	5	0
E/s Hidden Springs from Mountin View to Pigeon Pass	Oak	Trim	1	0	

ATTACHMENT 1

Zone	Street Section	Tree Species	Work to be Performed Trim or Removal	No of Trees to be Trimmed	No of Trees to be Removed
E-2 Hidden Springs (Cont.)	E/s Hidden Springs from Mountin View to Pigeon Pass	Pepper	Trim	5	0
	Hidden Springs Entry Median (all trees)	Eucalyptus	Trim	5	0
	W/s Hidden Springs from Pigeon Pass to Box Spring's Park Entrance	Eucalyptus	Trim	13	0
	W/s Hidden Springs from Pigeon Pass to Box Spring's Park Entrance	Pine	Trim	2	0
	W/s Hidden Springs from Pigeon Pass to Box Spring's Park Entrance	Pepper	Trim	17	0
	W/s Hidden Springs from Box Springs Parkw Entry to Country Gate	Eucalyptus	Trim	5	0
	W/s Hidden Springs from Box Springs Parkw Entry to Country Gate	Alder	Trim	4	0
	W/s Hidden Springs from Box Springs Parkw Entry to Country Gate	Bottle	Trim	7	0
	W/s corner of Country Gate and Hidden Springs	Tipawanna	Trim	2	0
	W/s Hidden Springs from Country Gate to Mountain View	Alder	Trim	14	0
	W/s Hidden Springs from Country Gate to Mountain View	Bottle	Trim	6	0
	W/s Hidden Springs from Country Gate to Mountain View	Tipawanna	Trim	3	0
	W/s Hidden Springs Mountain View to Del Cresta	Tipawanna	Trim	4	0
	W/s Hidden Springs Mountain View to Del Cresta	Bottle	Trim	5	0
	W/s Hidden Springs Mountain View to Del Cresta	Alder	Trim	1	0
	W/s Hidden Springs from Del Cresta to Country Crest	Oak	Trim	4	0
	W/s Hidden Springs from Del Cresta to Country Crest	Alder	Trim	2	0
	W/s Hidden Springs from Del Cresta to Country Crest	Bottle	Trim	36	0
	W/s Hidden Springs from Del Cresta to Country Crest	Bottle	Removal	0	1
	W/s Hidden Springs from Del Cresta to Country Crest	Alder	Removal	0	5
	W/s Pigeon Pass from Hiddden Springs to Hidden Springs	Bottle	Trim	22	0
W/s Pigeon Pass from Hiddden Springs to Hidden Springs	Tipawanna	Trim	16	0	
Paseo Behind 10192 Cartagena Dr.	Eucalyptus	Trim	1	0	
		Total (E-2)		280	7
E-3 MV Ranch - West	E/s of Kitching from Camino Marilena to Krameria	African Sumac	Trim	34	0
	S/s of Krameria from Kitching to Lasselle	African Sumac	Trim	18	0
	S/s of Krameria from Kitching to Lasselle	Oak	Trim	29	0
	S/s of Krameria from Lasselle to College	Oak	Trim	48	0
	N/s of Krameria from Lasselle to Kitching	African Sumac	Trim	43	0
	N/s of Krameria from Lasselle to Kitching	Oak	Trim	48	0
	E/s of Kitching from Krameria to Iris	African Sumac	Trim	22	0
	S/s of Iris from Kitching to Lasselle	African Sumac	Trim	19	0
	N/s of Iris from Los Cabos to Kitching	African Sumac	Trim	20	0
	E/s of Kitching from Iris to Gentian	African Sumac	Trim	36	0
	S/s of Gentian from Kitching to Lasselle	African Sumac	Trim	28	0
	W/s of Lasselle from Calle Agua to Krameria	African Sumac	Trim	13	0

ATTACHMENT 1

Page 2 of 6

Zone	Street Section	Tree Species	Work to be Performed Trim or Removal	No of Trees to be Trimmed	No of Trees to be Removed
E-3 MV Ranch - West (Cont.)	W/s of Lasselle from Krameria to Arroyo Park	African Sumac	Trim	20	0
	W/s of Lasselle from Arroyo Park to Camino Del Rey	Oak	Trim	24	0
	E/s of Lasselle St. from Kentucky Derby to Cremello	Oak	Trim	9	0
	E/s of Lasselle from Via Xavier to Krameria	African Sumac	Trim	14	0
	E/s of Lasselle from Iris to the High School	African Sumac	Trim	13	0
	SEC of Gentian & Lasselle	California Pepper	Trim	1	0
	SEC of Krameria & Kitching	California Pepper	Trim	1	0
	SWC of Gentian & Lasselle	California Pepper	Trim	1	0
	SEC of Iris & Kitching	California Pepper	Trim	1	0
	SWC of Iris & Lasselle	California Pepper	Trim	1	0
	NEC of Iris & Kitching	California Pepper	Trim	1	0
	SEC of Iris & Lasselle	California Pepper	Trim	1	0
	Both corners on the North Side of Iris & Ponderosa	California Pepper	Trim	2	0
	NEC of Krameria & Kitching	California Pepper	Trim	1	0
	Miscellaneous Removals throughout E-4	Misc.	Removals	0	14
Total (E-3)				448	14
E-4 MV Ranch - East	S/s of Iris Ave., from Hammet to Oliver	Pepper	Trim	4	0
	S/s of Iris Ave., from Hammet to Oliver	Pine	Trim	43	0
	S/s of Iris Ave., from Hammet to Oliver	Eucalyptus	Trim	40	0
	E/s of Oliver St., South of Iris Ave.	Pepper	Trim	2	0
	E/s of Oliver St., South of Iris Ave.	Palm	Trim	5	0
	S/s of Iris Ave., from Oliver St. to Via De Lago	Pine	Trim	3	0
	S/E side of Moreno Beach from Via De Lago	Pine	Trim	22	0
	S/E side of Moreno Beach from Via De Lago	Eucalyptus	Trim	14	0
	S/E and S/W corners of John F. Kennedy Dr. & Bayhill	Pepper	Trim	2	0
	S/s of John F. Kennedy Dr. from Bayhill to Championship	Pine	Trim	32	0
	S/s of John F. Kennedy Dr. from Bayhill to Championship	Eucalyptus	Trim	33	0
	S/E and S/W corners of Championship	Pepper	Trim	2	0
	S/E and S/W corners of Championship	Pine	Trim	3	0
	S/s of John F. Kennedy Dr. from Championship to Sevilla	Pine	Trim	33	0
	N/E and N/W corners of Sevilla	Pepper	Trim	2	0
	S/s of John F. Kennedy from Sevilla to Barcelona	Pine	Trim	32	0
	N/E and N/W corners of Barcelona	Pepper	Trim	1	0
	N/E and N/W corners of Barcelona	Pine	Trim	2	0
	S/E corner of Cactus and John F. Kennedy Dr.	Pepper	Trim	1	0
	S/E corner of Cactus and John F. Kennedy Dr.	Palms	Trim	9	0

ATTACHMENT 1

Zone	Street Section	Tree Species	Work to be Performed Trim or Removal	No of Trees to be Trimmed	No of Trees to be Removed
E-4 MV Ranch - East (Cont.)	S/W corner of Cactus and John F. Kennedy Dr.	Pepper	Trim	1	0
	S/W corner of Cactus and John F. Kennedy Dr.	Palms	Trim	11	0
	W/S of John F. Kennedy Dr. from Cactus to Championship	Pine	Trim	8	0
	W/S of John F. Kennedy Dr. from Championship Dr. to Moreno Beach Dr.	Pine	Trim	6	0
	SEC of Moreno Beach Drive and Cactus Ave.	Pepper	Trim	1	0
	SEC of Moreno Beach Drive and Cactus Ave.	Palms	Trim	11	0
	N/s of Iris Ave., from Ve a De Lago to Oliver St.	Pine	Trim	14	0
	N/s of Iris Ave., from Ve a De Lago to Oliver St.	Eucalyptus	Trim	6	0
	Miscellaneous Removals throughout E-3	Misc. Trees	Removals	0	20
		Total (E-4)			343
E-7 Centerpointe	W/S of Frederick from Alessandro Blvd. to Cactus Ave.	Pine	Trim	37	0
	S/W corner of Alessandro Blvd. and Frederick St.	Pepper	Trim	4	0
	S/W corner of Alessandro Blvd. and Frederick St.	Palm	Trim	3	0
	S/E corner of Alessandro Blvd. and Frederick St.	Pepper	Trim	4	0
	S/E corner of Alessandro Blvd. and Frederick St.	Palm	Trim	4	0
	N/W corner of Cactus Ave. and Frederick St.	Pepper	Trim	4	0
	N/W corner of Cactus Ave. and Frederick St.	Palm	Trim	5	0
	N/E corner of Cactus Ave. and Frederick St.	Pepper	Trim	4	0
	N/E corner of Cactus Ave. and Frederick St.	Palm	Trim	5	0
	E/s of Frederick St., from Cactus Ave. to Alessandro Blvd.	Pine	Tim	56	0
	Total (E-7)			126	0
E-8 Promontory Park	Morgan St. and John F. Kennedy Dr.	London Plane	Trim	5	0
	Corner of John F. Kennedy Dr., and Morgan St.	Pear	Trim	1	0
	Morgan St. and John F. Kennedy Dr.	Pear	Removal	0	1
	Total (E-8)			6	1
E-12 Stoneridge Ranch	Bloomfield St.	Palo Verde	Trim	4	0
	Nason St./Fir Ave./Eucalyptus Ave.	Palo Verde	Trim	15	0
	Total (E-12)			19	0
E-16 Shadow Mountain	E/s Pigeon Pass from Sunnymead Pkyway to Outlaw	Holy Oak	Trim	10	0
	E/s Pigeon Pass from Sunnymead Pkyway to Outlaw	Liquid Ambar	Trim	1	0
	E/s Pigeon Pass from Sunnymead Pkyway to Outlaw	Oak	Trim	2	0

ATTACHMENT 1

Zone	Street Section	Tree Species	Work to be Performed Trim or Removal	No of Trees to be Trimmed	No of Trees to be Removed
E-16 Shadow Mountain (Cont.)	E/s Pigeon Pass from Sunnymead Pkyway to Outlaw	Bottle	Trim	6	0
	S/s Presido Hills Dr. to Via Montara	Bottle	Trim	1	0
	S/s Presido Hills Dr. to Via Montara	Liquid Ambar	Trim	5	0
	Presido Hills Medians	Sagleaf Zelkova	Trim	1	0
	N/s Presido Hills from Via Montara to Pigeon Pass	Liquid Ambar	Trim	4	0
	N/s Presido Hills from Via Montara to Pigeon Pass	Bottle	Trim	1	0
	S/s Presido Hills Dr. from Montara to Via Del Norte	Liquid Ambar	Trim/Removal	6	1
	S/s Presido Hills Dr. from Via Del Norte to Epada Creek	Liquid Ambar	Trim	9	0
	S/s Presido Hills Dr. from Via Del Norte to Epada Creek	Oak	Trim	2	0
	W/s Epada Creek	Liquid Ambar	Trim/Removal	3	1
	W/s Via Del Norte from Presido Hills to Sunnymead Parkway	Liquid Ambar	Trim	4	0
	Sunnymead Pkway	Sagleaf Zelkova	Trim	12	0
	E/s Svía Del Norte - Slope behind Trail	Bottle	Trim	3	0
	E/s Svía Del Norte - Slope behind Trail	Holy Oak	Trim	5	0
	E/s Svía Del Norte - Slope behind Trail	Pine	Trim	2	0
	E/s Svía Del Norte - Slope behind Trail	Oak	Trim	2	0
	E/s Svía Del Norte - Slope behind Trail	Pepper	Trim	3	0
	W/s Via Del Norte	Pepper	Removal	0	1
	Total (E-16)				82
DSG-1 Tracts	TR 18283 N/s of Ironwood Ave., between Graham St. & Bayless	Sycamore	Removal	0	1
	TR 19142 Cactus Ave. and Parkwood	Pine	Removal	0	1
	TR 19541 Eucalyptus and Pepperbush St.	Plum	Removal	0	2
	TR 21597 Cactus Ave. and Kitching St. to Jonestown St.	Camphor	Trim	16	0
	TR 31129 Cactus Ave. and Dusty Coyote St.	Sumac African	Trim	20	0
Total (D - DSG-1)				36	4
DSG-2 Tracts	TR 17334 W/o Twilight	Sycamores	Trim	2	0
	TR 17334 W/o Twilight	Pine	Trim	3	0
	TR 17334 W/o Twilight	Queen Palm	Trim	1	0
	TR 17334 Twilight	Pine	Trim	4	0
	TR 17334 Twilight	Queen Palm	Trim	1	0
	TR 17334 W/o Twilight	Pine	Trim	16	0
	TR 17334 W/o Twilight	Palms	Trim	17	0
	TR 19032 Clark St.	Jacaranda	Trim	44	0
	TR 19032 Clark St.	Willow	Trim	1	0
	TR 19032 Clark St.	Pepper	Trim	1	0

ATTACHMENT 1

Zone	Street Section	Tree Species	Work to be Performed Trim or Removal	No of Trees to be Trimmmed	No of Trees to be Removed	
DSG-2 Tracts (Cont.)	TR 19032	Clark St.	Carrotwood	Trim	1	0
	TR 19032	Clark St.	Pine	Trim	10	0
	TR 19208	Along Ironwood Ave.	Palms	Trim	8	0
	TR 19208	Along Ironwood Ave.	Pine	Trim	15	0
	TR 19551	Ironwood Ave./Pigeon Pass Rd.	Sycamore	Trim	30	0
	TR 20525	East to Barbazon	Sycamores	Trim	26	0
	TR 20525	W/o Barbazon	Camphors	Trim	3	0
	TR 20525	Montecello	Camphors	Trim	3	0
	TR 20552	Along Heacock St.	Sycamore	Removal	0	1
	TR 21332	E/o Day St.	Liquid Ambar	Removal	0	1
	TR 21333	Ironwood Ave.	Liquid Ambar	Removal	0	1
	TR 22276	Morrison St., S/o Fir St.	Liquid Ambar	Removal	0	1
	TR 22277	Morrison St./Fir Ave.	Sycamore	Trim	3	0
	TR 22277	Morrison St./Fir Ave.	Pine	Trim	15	0
	TR 22277	Morrison St., N/o Fir St.	Liquid Ambar	Removal	0	1
	TR 22371	Eucalyptus Ave.	Plum	Trim	6	0
	TR 12773	Along Lasselle St, S/o John F. Kennedy Dr.	Liquid Ambar	Removal	0	4
	TR 17867	Lasselle St.	Pine	Trim	10	0
	TR 19434	Along Kitching St.	Liquid Ambar	Removal	0	4
	TR 19685	Lasselle St., Gentian Ave., Kitching St.	Palms	Trim	31	0
	TR 19957	Along Frederick St.	Liquid Ambar	Removal	0	3
	TR 20859	Perris Blvd.	Sycamore	Trim	26	0
	TR 20859	Along Perris Blvd., S/o Krameria Ave.	Sycamore	Removal	0	1
	TR 30027	Dracea Ave., Nason St., Cottonwood Ave.	Jacarandas	Trim	18	0
	TR 32018	Along Cottonwood Ave.	Liquid Ambar	Removal	0	1
			Total (D - DSG- 2 North)		295	18
			Grand Total		1,808	67

ATTACHMENT 1

Page 6 of 6

This page intentionally left blank.

INDEPENDENT CONTRACTOR AGREEMENT

R.F.P. NO. 2011 TREE TRIM/REMOVAL
PROJECT NO. 2011 TREE TRIM/REMOVAL

PARKWAY AND MEDIAN
TREE TRIMMING AND REMOVAL

This Contract Agreement, effective as of the day signed by the City Manager (acting in the capacity of District Manager to the Moreno Valley Community Services District) or Mayor (acting in the capacity of President to the Moreno Valley Community Services District), is made between the Moreno Valley Community Services District, a Community Services District established pursuant to Section 61000 and following of the California Government Code, hereinafter referred to as the "District", and the following named independent contractor, hereinafter referred to as the "Contractor," based upon District policies and the following legal citations:

- A. Government Code Section 53060 authorizes the engagement of persons to perform special services as independent contractors; and
- B. The public interest, convenience, necessity and general welfare will be served by this Agreement.

1. CONTRACTOR INFORMATION:

Contractor's Name	West Coast Arborists, Inc.
Street Address	2200 E. Burton Street
Street Address	
City, State, Zip	Anaheim, CA 92806
Mailing Address	
(If same as Street Address, write same or same as above)	Same as Above
Business Phone (with area code)	(714) 991-1900
Cell or Mobile Phone (with area code)	
Other Contact Number (with area code)	(909) 783-6544
Fax Number	(714) 991-1027
Email Address	www.WCAINC.com
Social Security Number	
Business License Number	
Federal Tax ID Number	95-3250682
Contractor's License Number & Classification	366764 C27/C61/D49

2. CONTRACTOR SERVICES, FEES, AND RELEVANT DATES:

- A. The Contractor's scope of work, responsibilities, requirements, provisions, and additional terms and conditions required to be performed by the Contractor the services of this RFP are described in Exhibit "A" attached hereto and incorporated herein by this reference.

- B. The District's responsibilities, other than payment, are described in Exhibit "B" attached hereto and incorporated herein by this reference.
- C. Payment terms are provided in Exhibit "C" attached hereto and incorporated herein by this reference.
- D. The Contract Starting Date is November 1, 2011 and the Contract Ending Date is June 30, 2012. Any provisions for extending the term of the Contract for subsequent terms are provided in Exhibit "D" attached hereto and incorporated herein by this reference. The District acknowledges that it will not unreasonably withhold approval of the Contractor's requests for extensions of time in which to complete the work required. The Contractor shall not be responsible for performance delays caused by others or delays beyond the Contractor's reasonable control (excluding delays caused by non-performance or unjustified delay by Contractor, his/her/its employees, or subcontractors), and such delays shall extend the time for performance of the work by the Contractor.
- E. Contractor's Proposal, including but not limited to the Bid Schedule, Additional Work Price List, Contract Proposal, Proposed Project Work Schedules, Proposed Annual Material Schedule, Contractor Information, Certification of Non-Discrimination, and List of Subcontractors, are described in Exhibit "E" attached hereto and incorporated by this reference.

3. STANDARD TERMS AND CONDITIONS:

- A. Control of Work. Except for compliance with specifications and performance standards provided for in Exhibit "A," the Contractor is solely responsible for the content and sequence of the work, and will not be subject to control and direction as to the details and means for accomplishing the anticipated results of services. The District will not provide, nor be responsible to provide, any training to the Contractor or his/her/its employees.
- B. Intent of Parties. Contractor is, and at all times shall be, an independent contractor and nothing contained herein shall be construed as making the Contractor or any individual whose compensation for services paid by the Contractor, an agent or employee of the District, or authorizing the Contractor to create or assume any obligation or liability for or on behalf of the District, or entitling the Contractor to any right, benefit, or privilege applicable to any officer or employee of the District.
- C. Subcontracting. Contractor may retain or subcontract for the services of other necessary contractors with the prior written approval of the District. Payment for such services shall be the responsibility of the Contractor. Any and all subcontractors shall be subject to the terms and conditions of this Contract, with the exception that the District shall have no obligation to pay for any subcontractor services rendered. Contractor shall be responsible for paying prevailing wages where required by law [See California Labor Code Sections 1770 through 1777.7].
- D. Legal Considerations. The Contractor shall comply with applicable federal, state, and local laws in the performance of this Contract.

E. Contractor Indemnification. Contractor shall indemnify, defend and hold the City of Moreno Valley (City), the Community Redevelopment Agency of the City of Moreno Valley (RDA), and the Moreno Valley Community Services District (CSD), their officers, agents and employees harmless from any and all claims, damages, losses, causes of action and demands, including reasonable attorney's fees and costs, incurred in connection with or in any manner arising out of Contractor's performance of the work contemplated by this Contract. Acceptance of these terms by both parties constitutes a Contract and signifies that the Contractor is not covered under the City's general liability insurance, employee benefits, or worker's compensation. It further establishes that the Contractor shall be fully responsible for such coverage.

F. District Indemnification. The District agrees to indemnify, defend and save the Contractor and his/her/its officers, agents and employees harmless from any and all liability, claims, damages or injuries to any person, including injury to the City's, RDA's and the District's employees and all claims which arise from or are connected with the negligent performance or failure to perform the services or other obligations of the District under this Contract, or are caused or claim to be caused by the negligent acts of the City, RDA, and the District, their officers, agents or employees, or its subcontractor(s) or any person acting for the District or under its control or direction; provided, however, that this indemnification and hold harmless shall not include any claims arising from the sole negligence or willful misconduct of the Contractor, its officers, agent, employees, or subcontractors.

G. Insurance Requirements. Where determined applicable by the District, Contractor will comply with the following insurance requirements at its sole expense. Insurance companies shall be rated (A Minus: VII—Admitted) or better in Best's Insurance Rating Guide and shall be legally licensed and qualified to conduct business in the State of California:

General Liability Insurance—to protect against loss from liability imposed by law for damages on account of bodily injury, including death, and/or property damage suffered or alleged to be suffered by any person or persons whomever, resulting directly or indirectly from any act or activities of the Contractor, subcontractor, or any person acting for the Contractor or under its control or direction. Such insurance shall be maintained in full force and effect throughout the terms of the Contract and any extension thereof in the minimum amounts provided below:

Bodily Injury	\$1,000,000 per occurrence/ \$2,000,000 aggregate
Property Damage	\$1,000,000 per occurrence/ \$2,000,000 aggregate

Professional Errors and Omission Insurance—such coverage shall not be less than \$1,000,000 per claim and aggregate.

Worker's Compensation Insurance—in such amounts as will fully comply with the laws of the State of California and which shall indemnify, insure and provide legal defense for both the Contractor and the City, RDA, and District, against any loss, claim or damage arising from any injuries or occupational diseases happening to any worker employed by the Contractor in the course of carrying out the

Agreement. This coverage may be waived if the Contractor is determined to be functioning as a sole proprietor and the city provided form "Exception to Worker's Compensation Coverage" is signed, notarized and attached to this Contract

Liability and Property Damage Insurance coverage for owned and non-owned automotive equipment operated on City/RDA/District premises. Such coverage limits shall not be less than \$1,000,000 combined single limit.

Insurance requirements waived with Risk Manager's approval.
By: _____ Date: _____
(Risk Manager)

Insurance requirements modified with Risk Manager's approval and attached hereto as Exhibit "F" and incorporated herein by this reference.

A Certificate of Insurance and appropriate additional insured endorsement evidencing the above applicable insurance coverage shall be submitted to the City's Risk Manager prior to the execution of this Contract. The Certificate of Insurance or an appropriate binder shall bear an endorsement containing the following provisions:

Solely as respect to services done by or on behalf of the named insured for the Moreno Valley Community Services District, it is agreed that the City of Moreno Valley, the Community Redevelopment Agency of the City of Moreno Valley, and the Moreno Valley Community Services District, their officers, employees and agents are included as additional insured under this policy and the coverage(s) provided shall be primary insurance and not contributing with any other insurance available to the City of Moreno Valley, the Community Redevelopment Agency of the City of Moreno Valley, and the Moreno Valley Community Services District, their officers, employees and agents, under any third party liability policy.

The terms of the insurance policy or policies issued to provide the above coverage shall neither be amended to reduce the required insurance limits and coverages nor shall such policies be canceled by the carrier without thirty (30) days prior written notice by certified or registered mail to the City of amendment or cancellation to the District, except that cancellation for non-payment of premium shall require ten (10) days prior written notice by certified or registered mail. In the event the insurance is canceled, the Contractor shall, prior to the cancellation date, submit to the Risk Manager new evidence of insurance in the amounts established.

H. Intellectual Property. Any system or documents developed, produced or provided under this Contract, including any intellectual property discovered or developed by Contractor in the course of performing or otherwise as a result of its work, shall become the sole property of the District unless explicitly stated otherwise in this Contract. The Contractor may retain copies of any and all material, including drawings, documents, and specifications, produced by the Contractor in performance of this Contract. The District and the Contractor agree that to the extent permitted by law, until final approval by the District, all data shall be treated

as confidential and will not be released to third parties without the prior written consent of both parties.

- I. Entire of the Contract. This Contract constitutes the entire agreement between the parties. There are no understandings, agreements, or representations of warranties, expressed or implied, not specified in this Contract. This Contract applies only to the proposal attached. This Contract may be modified or amended either by a subsequent written Contract signed by both parties or as provided for in Section 3, Paragraph K, Notice of Service Level Adjustment. Assignment of this Contract is prohibited without prior written consent.
- J. Termination.
1. Either party may terminate this Contract upon breach of the Contract by the other party. In the event the District terminates the Contract, the Contractor shall perform no further services under the Contract unless the notice of termination authorizes such further work.
 2. The District may terminate this Contract without fault on the part of the Contractor by giving at least ten (10) days written notice to the Contractor. The written notice shall specify the date of termination. Upon receipt of such notice, the Contractor may continue services on the project through the date of termination, provided that no service(s) shall be commenced or continued after receipt of the notice, which is not intended to protect the interest of the District. The District shall pay the Contractor within thirty (30) days after the date of termination for all non-objected to services performed by the Contractor in accordance herewith through the date of termination.
- K. Notice of Service Level Adjustments. A minimum 30 day written notice to the Contractor shall be provided by the District regarding any reduction or addition of service to be provided by the Contractor in accordance with the terms of the Contract. It will be the responsibility of the Contractor to provide a revised schedule of service within 30 days of the receipt of notice and to adjust monthly invoicing in accordance with the terms of the reduction or addition to the service area.
- L. Payment. Payments to the Contractor, pursuant to this Contract will be reported to Federal and State taxing authorities as required. The District will not withhold any sums from compensation payable to Contractor, except as provided for in Exhibit "C". Contractor is independently responsible for the payment of all applicable taxes. Where the payment terms provide for compensation on a time and materials basis, the Contractor shall maintain adequate records to permit inspection and audit of the Contractor's time and materials charges under the Contract. Upon reasonable notice, such records must be made available to the District's agent; however, nothing herein shall convert such records into public records. Such records shall be retained by the Contractor for three (3) years following completion of the services under the Contract.
- M. Restrictions on District / City Employees. The Contractor shall not employ any

District or City employee or official in the work performed pursuant to this Contract. No officer or employee of the District or City shall have any financial interest in this Contract in violation of federal, state, or local laws.

- N. Choice of Law and Venue. The laws of the State of California shall govern the rights, obligations, duties, and liabilities of the parties to this Contract, and shall govern the interpretation of this Contract. Any legal proceeding arising from this Contract shall be brought in the appropriate court located in Riverside County, State of California.
- O. Notices. All notices, requests, demands or other communications ("notice") under this Contract by any party shall be in writing, shall be properly addressed as set forth below (or to such other address as any party may later designate), and shall be sufficiently given on the date: (a) of service if served personally upon the person to whom notice is to be given, (b) receipt is confirmed with the addressee by telephone if a notice is sent by telex, telecopier, facsimile or other telecommunication facility, or (c) of receipt if a notice is sent by courier or by registered or certified mail, return receipt requested, postage prepaid:

To Contractor: 2200 E. Via Burton St., Anaheim, CA 92806
[Mailing Address (Post Office Box, if applicable)]
(714) 991-1900
[Telephone number]
(714) 991-1027
[Fax number]
vgonnale@wcainc.com
[Email address]

With a copy to:
[Attorney for Contractor, if applicable]
[Street Address]
[Post Office Box, if applicable]
[City, State, Zip]
[Telephone number]
[Fax number]
[Email address]

To CSD: MORENO VALLEY COMMUNITY SERVICES DISTRICT
Public Works Department
Special Districts Division
14177 Frederick Street
P. O. Box 88005
Moreno Valley, CA 92552-0805
Attn: Special Districts Division Manager
Telephone number: 951. 413-3480
Fax Number: 951. 413-3498

With a copy to: City Attorney's Office [if applicable]
14177 Frederick Street
P. O. Box 88005
Moreno Valley, CA 92552-0805
Attn: City Attorney
Telephone number: 951. 413-3036
Fax number: 951. 413-3034

SIGNATURE PAGE TO FOLLOW:

SIGNATURE PAGE

IN WITNESS HEREOF, the parties have each caused their authorized representative to execute this Agreement

Moreno Valley Community Services District

By: *Michelle Hausman*
Title: City Manager, acting in the capacity of
for District Manager of the Board of
Directors of the Moreno Valley
Community Services District

Date: 11/15/11

West Coast Arborists, Inc.

By: *[Signature]* Patrick Mahoney
Title: (President or Vice President)

Date: NOVEMBER 1, 2011

INTERNAL USE ONLY

ATTEST:

City Clerk
(For City Council or CSD Board Approvals)

APPROVED AS TO LEGAL FORM:

[Signature]
City Attorney

17 Nov 2011
Date

RECOMMENDED FOR APPROVAL:

[Signature]
Department Head

11.14.11
Date

By: *[Signature]* Richard Mahoney
Title: Corporate Secretary or Assistant
Secretary
(If applicable)

Date: NOVEMBER 1, 2011

Affix Corporate Seal Below
(If applicable)

Attachments

** THE EFFECTIVE DATE OF THE BOND SHALL BE FROM 11-1-11 THROUGH 6-30-12 AND SURETY SHALL NOT BE LIABLE FOR ANY DEFAULTS OR EVENTS ARISING EITHER BEFORE OR AFTER THE EFFECTIVE DATE OF THE BOND. AT SOLE OPTION OF THE SURETY, THE BOND MAY ONLY BE RENEWED BY CONTINUATION OR RENEWAL CERTIFICATE, AND/OR RIDER SETTING FORTH NEW COMMENCEMENT AND EXPIRATION DATES. NON-RENEWAL OF THE BOND, WHETHER OR NOT A BREACH OF CONTRACT, SHALL NOT BE CONSIDERED A BREACH WITHIN THE EFFECTIVE PERIOD OF THE BOND.

IN WITNESS WHEREOF, this instrument has been duly executed by the Principal and Surety above-named, on NOVEMBER 1, 2011.

PRINCIPAL

SURETY

Name: WEST COAST ARBORISTS, INC.

Name: CONTRACTORS BONDING AND INSURANCE COMPANY

Address: 2200 E. VIA BURTON STREET
ANAHEIM, CA 92806

Address: 111 PACIFICA, SUITE 350
IRVINE, CA 92618

Telephone Number: 714/991-1900

Telephone Number: (949) 341-9110

By: 
PATRICK MAHONEY

By: 
MICHAEL D. STONE

Title: PRESIDENT

Title: ATTORNEY-IN-FACT

By: 
RICHARD MAHONEY

By: _____

Title: VICE-PRESIDENT/ASST. SECRETARY Title: _____

Approved as to form this 17th day of Nov, 2011

City Attorney, in the Capacity of General Legal Counsel
to the Moreno Valley Community Services District

(MUST BE ACKNOWLEDGED BEFORE A NOTARY BY BOTH PRINCIPAL AND SURETY)

RISK MANAGEMENT
Approved

 11-15-11
By Date

CALIFORNIA ALL-PURPOSE ACKNOWLEDGMENT

State of California

County of Orange

On 11/3/11 before me, Victor M. Gonzalez, Notary Public
Date Here Insert Name and Title of the Officer

personally appeared Patrick Mahoney and Richard Mahoney
Name(s) of Signer(s)

who proved to me on the basis of satisfactory evidence to be the person(s) whose name(s) is/are subscribed to the within instrument and acknowledged to me that he/she/they executed the same in his/her/their authorized capacity(ies), and that by his/her/their signature(s) on the instrument the person(s), or the entity upon behalf of which the person(s) acted, executed the instrument.

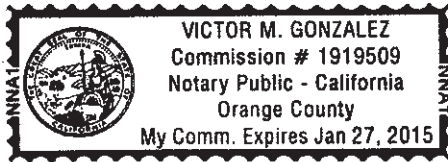

I certify under PENALTY OF PERJURY under the laws of the State of California that the foregoing paragraph is true and correct.

WITNESS my hand and official seal.

Signature *Victor M. Gonzalez*
Signature of Notary Public

Place Notary Seal Above

OPTIONAL

Though the information below is not required by law, it may prove valuable to persons relying on the document and could prevent fraudulent removal and reattachment of this form to another document.

Description of Attached Document

Title or Type of Document: APPENDIX E: BOND FORMS - FAITHFUL PERFORMANCE

Document Date: 11/1/11 Number of Pages: 2

Signer(s) Other Than Named Above: _____

Capacity(ies) Claimed by Signer(s)

Signer's Name: Patrick Mahoney

- Individual
- Corporate Officer — Title(s): President
- Partner — Limited General
- Attorney in Fact
- Trustee
- Guardian or Conservator
- Other: _____

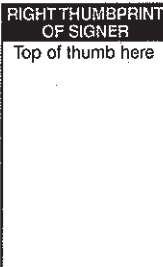

Signer Is Representing: West Coast Arborists, Inc.

Signer's Name: Richard Mahoney

- Individual
- Corporate Officer — Title(s): V.P./Asst. Secretary
- Partner — Limited General
- Attorney in Fact
- Trustee
- Guardian or Conservator
- Other: _____

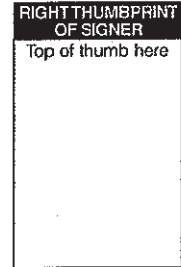

Signer Is Representing: West Coast Arborists, Inc.

CALIFORNIA ALL-PURPOSE CERTIFICATE OF ACKNOWLEDGMENT

State of California

County of RIVERSIDE

On 11/1/11 before me, R. NAPPI "NOTARY PUBLIC"
(Here insert name and title of the officer)

personally appeared MICHAEL D. STONG

who proved to me on the basis of satisfactory evidence to be the person(s) whose name(s) is/are subscribed to the within instrument and acknowledged to me that he/she/they executed the same in his/her/their authorized capacity(ies), and that by his/her/their signature(s) on the instrument the person(s), or the entity upon behalf of which the person(s) acted, executed the instrument.

I certify under PENALTY OF PERJURY under the laws of the State of California that the foregoing paragraph is true and correct.

WITNESS my hand and official seal.

R. Nappi
Signature of Notary Public

(Notary Seal)

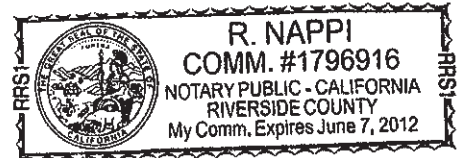

ADDITIONAL OPTIONAL INFORMATION

DESCRIPTION OF THE ATTACHED DOCUMENT

(Title or description of attached document)

(Title or description of attached document continued)

Number of Pages _____ Document Date _____

(Additional information)

CAPACITY CLAIMED BY THE SIGNER

- Individual (s)
 Corporate Officer

(Title)

- Partner(s)
 Attorney-in-Fact
 Trustee(s)
 Other _____

INSTRUCTIONS FOR COMPLETING THIS FORM

Any acknowledgment completed in California must contain verbiage exactly as appears above in the notary section or a separate acknowledgment form must be properly completed and attached to that document. The only exception is if a document is to be recorded outside of California. In such instances, any alternative acknowledgment verbiage as may be printed on such a document, so long as the verbiage does not require the notary to do something that is illegal for a notary in California (i.e. certifying the authorized capacity of the signer). Please check the document carefully for proper notarial wording and attach this form if required.

- State and County information must be the State and County where the document signer(s) personally appeared before the notary public for acknowledgment.
- Date of notarization must be the date that the signer(s) personally appeared which must also be the same date the acknowledgment is completed.
- The notary public must print his or her name as it appears within his or her commission followed by a comma and then your title (notary public).
- Print the name(s) of document signer(s) who personally appear at the time of notarization.
- Indicate the correct singular or plural forms by crossing off incorrect forms (i.e. he/she/they, is /are) or circling the correct forms. Failure to correctly indicate this information may lead to rejection of document recording.
- The notary seal impression must be clear and photographically reproducible. Impression must not cover text or lines. If seal impression smudges, re-seal if a sufficient area permits, otherwise complete a different acknowledgment form.
- Signature of the notary public must match the signature on file with the office of the county clerk.
 - ❖ Additional information is not required but could help to ensure this acknowledgment is not misused or attached to a different document.
 - ❖ Indicate title or type of attached document, number of pages and date.
 - ❖ Indicate the capacity claimed by the signer. If the claimed capacity is a corporate officer, indicate the title (i.e. CEO, CFO, Secretary).
- Securely attach this document to the signed document

BOND NUMBER CF 4281
PREMIUM INCLUDED IN PERFORMANCE BOND
EXECUTED IN DUPLICATE

APPENDIX D: BOND FORMS – MATERIAL AND LABOR

BOND NO.:
MATERIALS AND LABOR BOND

R.F.P. NO. 2011 TREE TRIM/REMOVAL
PROJECT NO. 2011 TREE TRIM/REMOVAL

PARKWAY AND MEDIAN TREE TRIMMING AND REMOVAL

KNOW ALL MEN BY THESE PRESENTS,

THAT WEST COAST ARBORISTS, INC., as Principal,
and CONTRACTORS BONDING AND INSURANCE COMPANY, as Surety, as held
firmly bound unto the Moreno Valley Community Services District, in the just and full amount
of NINETY-THREE THOUSAND TWO HUNDRED TWENTY AND NO/100 dollars (\$ 93,220.00 - -)
(amount in words and figures), for the payment whereof, we hereby bind ourselves, our heirs,
executors, administrators, successors, and assigns, jointly and severally, firmly by these
presents.

Given under our hands and sealed with our seals this 1st day of NOVEMBER, 2011.

The condition of the foregoing obligation is such that,

WHEREAS, the above-named Principal is about to enter into a Contract with the Moreno Valley Community Services District whereby said principal agrees to provide tree trimming and/or removal services as required in accordance with the provisions of PROJECT NO. PMTTRES/11, as provided in said Contract, which said Contract is hereby referred to and made a part hereof to the same extent as if the same were herein specifically set forth;

NOW, THEREFORE, if the said Principal or any subcontractor of said Principal shall fail to pay for any materials, provisions, provider of other supplies, or teams used in, upon, for or about the performance of said work contracted to be done, or for any work or labor thereon of any kind, or for amounts due under the Unemployment Insurance Act with respect to such work or labor, the Surety will pay for the same in an amount not exceeding the sum hereinabove specified, and in case suit is brought hereon, a reasonable attorney's fee to be fixed by the Court, otherwise this bond shall be void and of no effect;

PROVIDED, that no amendment, change, extension of time, alteration, or addition to said Contract or Agreement, or of any feature or item or items or performance required therein or thereunder shall in any manner effect the obligation of the undersigned on or under this bond; and the surety does hereby waive notice of such amendment, limitation of time for bringing action on this bond by the District change, extension of time, alteration or addition to said Contract or Agreement, and of any feature or item or items of performance required herein or thereunder.

This bond shall inure to the benefit of any and all persons entitled to file claims under Sections 3181 through 3187 of the Civil Code of the State of California, and shall give right of action to such persons or their assigns in any suit brought upon this bond.

** THE EFFECTIVE DATE OF THE BOND SHALL BE FROM 11-1-11 THROUGH 6-30-11 AND SURETY SHALL NOT BE LIABLE FOR ANY DEFAULTS OR EVENTS ARISING EITHER BEFORE OR AFTER THE EFFECTIVE DATE OF THE BOND. AT SOLE OPTION OF THE SURETY, THE BOND MAY ONLY BE RENEWED BY CONTINUATION OR RENEWAL CERTIFICATE, AND/OR RIDER SETTING FORTH NEW COMMENCEMENT AND EXPIRATION DATES. NON-RENEWAL OF THE BOND, WHETHER OR NOT A BREACH OF CONTRACT, SHALL NOT BE CONSIDERED A BREACH WITHIN THE EFFECTIVE PERIOD OF THE BOND.

WITNESS our hands this 1st day of NOVEMBER, 20 11.

PRINCIPAL

SURETY

Name: WEST COAST ARBORISTS, INC.

Name: CONTRACTORS BONDING AND INSURANCE COMPANY

Address: 2200 E. VIA BURTON STREET
ANAHEIM, CA 92806

Address: 111 PACIFICA, SUITE 350
IRVINE, CA 92618

Telephone Number: 714/991-1900

Telephone Number: (949) 341-9110

By: [Signature]
PATRICK MAHONEY

By: [Signature]
MICHAEL D. STONG

Title: PRESIDENT

Title: ATTORNEY-IN-FACT

By: [Signature]
RICHARD MAHONEY

By: _____

Title: VICE-PRESIDENT/ASST. SECRETARY Title: _____

Approved as to form this 17th day of Nov, 20 11.

[Signature]
City Attorney, in the Capacity of General Legal Counsel
to the Moreno Valley Community Services District

(MUST BE ACKNOWLEDGED BEFORE A NOTARY BY BOTH PRINCIPAL AND SURETY)

RISK MANAGEMENT
Approved

[Signature] 11-15-11
By Date

CALIFORNIA ALL-PURPOSE ACKNOWLEDGMENT

State of California

County of Orange

On 11/3/11 before me, Victor M. Gonzalez, Notary Public
Date Here Insert Name and Title of the Officer

personally appeared Patrick Mahoney and Richard Mahoney
Name(s) of Signer(s)

who proved to me on the basis of satisfactory evidence to be the person(s) whose name(s) is(are) subscribed to the within instrument and acknowledged to me that he/she/they executed the same in his/her/their authorized capacity(ies), and that by his/her/their signature(s) on the instrument the person(s) or the entity upon behalf of which the person(s) acted, executed the instrument.

I certify under PENALTY OF PERJURY under the laws of the State of California that the foregoing paragraph is true and correct.

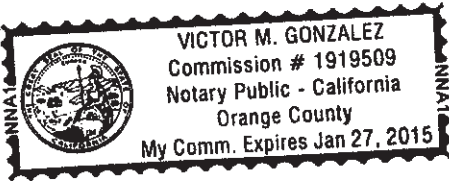

WITNESS my hand and official seal

Signature [Handwritten Signature]
Signature of Notary Public

Place Notary Seal Above

OPTIONAL

Though the information below is not required by law, it may prove valuable to persons relying on the document and could prevent fraudulent removal and reattachment of this form to another document.

Description of Attached Document

Title or Type of Document: APPENDIX D: BOND FORMS - MATERIAL AND LABOR

Document Date: 11/1/11 Number of Pages: 2

Signer(s) Other Than Named Above: _____

Capacity(ies) Claimed by Signer(s)

Signer's Name: Patrick Mahoney

- Individual
- Corporate Officer — Title(s): President
- Partner — Limited General
- Attorney in Fact
- Trustee
- Guardian or Conservator
- Other: _____

RIGHT THUMBPRINT OF SIGNER
 Top of thumb here

Signer Is Representing: West Coast Arborists, Inc.

Signer's Name: Richard Mahoney

- Individual
- Corporate Officer — Title(s): V.P./Asst. Secretary
- Partner — Limited General
- Attorney in Fact
- Trustee
- Guardian or Conservator
- Other: _____

RIGHT THUMBPRINT OF SIGNER
 Top of thumb here

Signer Is Representing: West Coast Arborists, Inc.

CALIFORNIA ALL-PURPOSE CERTIFICATE OF ACKNOWLEDGMENT

State of California

County of RIVERSIDE

On 11/1/11 before me, R. NAPPI "NOTARY PUBLIC"
(Here insert name and title of the officer)

personally appeared MICHAEL D. STONG

who proved to me on the basis of satisfactory evidence to be the person(s) whose name(s) is/are subscribed to the within instrument and acknowledged to me that he/she/they executed the same in his/her/their authorized capacity(ies), and that by his/her/their signature(s) on the instrument the person(s), or the entity upon behalf of which the person(s) acted, executed the instrument.

I certify under PENALTY OF PERJURY under the laws of the State of California that the foregoing paragraph is true and correct.

WITNESS my hand and official seal.

R. Nappi
Signature of Notary Public

(Notary Seal)

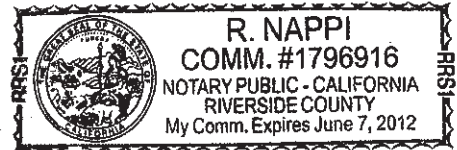

ADDITIONAL OPTIONAL INFORMATION

DESCRIPTION OF THE ATTACHED DOCUMENT

(Title or description of attached document)

(Title or description of attached document continued)

Number of Pages _____ Document Date _____

(Additional information)

CAPACITY CLAIMED BY THE SIGNER

- Individual (s)
 Corporate Officer

(Title)

- Partner(s)
 Attorney-in-Fact
 Trustee(s)
 Other _____

INSTRUCTIONS FOR COMPLETING THIS FORM

Any acknowledgment completed in California must contain verbiage exactly as appears above in the notary section or a separate acknowledgment form must be properly completed and attached to that document. The only exception is if a document is to be recorded outside of California. In such instances, any alternative acknowledgment verbiage as may be printed on such a document so long as the verbiage does not require the notary to do something that is illegal for a notary in California (i.e. certifying the authorized capacity of the signer). Please check the document carefully for proper notarial wording and attach this form if required.

- State and County information must be the State and County where the document signer(s) personally appeared before the notary public for acknowledgment.
- Date of notarization must be the date that the signer(s) personally appeared which must also be the same date the acknowledgment is completed.
- The notary public must print his or her name as it appears within his or her commission followed by a comma and then your title (notary public).
- Print the name(s) of document signer(s) who personally appear at the time of notarization.
- Indicate the correct singular or plural forms by crossing off incorrect forms (i.e. he/she/they, is /are) or circling the correct forms. Failure to correctly indicate this information may lead to rejection of document recording.
- The notary seal impression must be clear and photographically reproducible. Impression must not cover text or lines. If seal impression smudges, re-seal if a sufficient area permits, otherwise complete a different acknowledgment form.
- Signature of the notary public must match the signature on file with the office of the county clerk.
 - ❖ Additional information is not required but could help to ensure this acknowledgment is not misused or attached to a different document.
 - ❖ Indicate title or type of attached document, number of pages and date.
 - ❖ Indicate the capacity claimed by the signer. If the claimed capacity is a corporate officer, indicate the title (i.e. CEO, CFO, Secretary).
- Securely attach this document to the signed document



Contractors Bonding and Insurance Company
 1213 Valley Street
 P.O. Box 9271
 Seattle, WA 98109-0271

POWER OF ATTORNEY

Contractors Bonding and Insurance Company

Know All Men by These Presents:

That this Power of Attorney is not valid or in effect unless attached to the bond which it authorizes executed, but may be detached by the approving officer if desired.

That **Contractors Bonding and Insurance Company**, a Washington corporation, does hereby make, constitute and appoint: Jeremy Pendergast, Rosemary Nappi, Michael D. Stong, jointly or severally.

in the City of Riverside, State of California its true and lawful Agent and Attorney in Fact, with full power and authority hereby conferred, to sign, execute, acknowledge and deliver for and on its behalf as Surety, the following described bond.

Any and all bonds, undertakings, and recognizances in an amount not to exceed Ten Million and 00/100 Dollars (\$10,000,000.00) for any single obligation.

The acknowledgment and execution of such bond by the said Attorney in Fact shall be as binding upon this Company as if such bond had been executed and acknowledged by the regularly elected officers of this Company.

The **Contractors Bonding and Insurance Company** further certifies that the following is a true and exact copy of the Resolution adopted by the Board of Directors of **Contractors Bonding and Insurance Company**, and now in force to-wit:

"All bonds, policies, undertakings, Powers of Attorney or other obligations of the Corporation shall be executed in the corporate name of the Corporation by the President, Secretary, any Assistant Secretary, Treasurer, or any Vice President, or by such other officers as the Board of Directors may authorize. The President, any Vice President, Secretary, any Assistant Secretary, or the Treasurer may appoint Attorneys in Fact or Agents who shall have authority to issue bonds, policies or undertakings in the name of the Corporation. The corporate seal is not necessary for the validity of any bonds, policies, undertakings, Powers of Attorney or other obligations of the Corporation. The signature of any such officer and the corporate seal may be printed by facsimile or other electronic image."

IN WITNESS WHEREOF, the **Contractors Bonding and Insurance Company** has caused these presents to be executed by its Vice President with its corporate seal affixed this 11th day of July, 2011.



Contractors Bonding and Insurance Company

Roy C. Die Vice President

State of Washington }
 County of King } SS

On this 11th day of July, 2011, before me, a Notary Public, personally appeared Roy C. Die, who being by me duly sworn, acknowledged that he signed the above Power of Attorney as the aforesaid officer of the **Contractors Bonding and Insurance Company** and acknowledged said instrument to be the voluntary act and deed of said corporation.

Joseph B. Muller
 Joseph B. Muller Notary Public

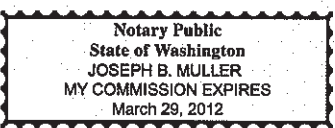

CERTIFICATE

I, the undersigned officer of **Contractors Bonding and Insurance Company**, a stock corporation of the State of Washington, do hereby certify that the attached Power of Attorney is in full force and effect and is irrevocable; and furthermore, that the Resolution of the Company as set forth in the Power of Attorney, is now in force. In testimony whereof, I have hereunto set my hand and the seal of the **Contractors Bonding and Insurance Company** this 10th day of October, 2011.

Contractors Bonding and Insurance Company

Roy C. Die Vice President

EXHIBIT A
R.F.P. NO. 2011 TREE TRIM/REMOVAL
PROJECT NO. 2011 TREE TRIM/REMOVAL

PARKWAY AND MEDIAN
TREE TRIMMING AND REMOVAL

1. SCOPE OF WORK

- A. The work to be performed under this Contract shall include the furnishing of all labor, material, and equipment necessary for the provision of tree trimming and removal services within the boundaries of the various zones of the District as determined in the resolutions of the City Council establishing said zones, and as said boundaries may have been heretofore or may be hereafter altered, and as more particularly shown on the Project Location Maps and described on the tree trimming/removal list as attached at the end of this Exhibit.
- B. The Contractor shall have the duty to perform tree trimming and/or tree removal services. All work shall be performed in accordance with usual and customary horticultural practices to achieve and maintain healthy, viable trees. The Director of Public Works of the City of Moreno Valley, or his/her delegated representative(s), hereinafter designated as "Director" will periodically inspect all the operations and approve or reject the work performed, and methods or materials used, and make changes in work scheduling.
- C. The Contractor shall be responsible for carefully reviewing the site(s), and verifying the trees noted for each location of proposed work is included in the Proposal. The Contractor shall not be relieved of his/her liability under this Contract, nor the District or City be held liable for any loss sustained by the Contractor as a result of any variance between conditions as referred to in the Technical Provisions, and the actual conditions revealed during the examination of the locations of the proposed work.

2. SCHEDULING OF WORK

- A. The Contractor shall adhere to the facilities, equipment and annual work schedules submitted as a part of the Contractor's bid, and incorporated herein by this reference. These schedules, and any approved revisions thereto, shall be used by the District as a basis for determining Contractor's satisfactory performance.
- B. Revisions to facilities, equipment, and annual work schedules shall not be implemented without the prior written approval of the Director. The Contractor shall submit proposed revisions to equipment and annual work schedules in writing to the District at the address as set forth in Section 3, paragraph O. of the Independent Contractor Agreement "Contract" at least ten (10) working days prior to commencing work per the proposed revisions.
- C. Failure to submit proposed revisions to equipment, staffing, or work schedules by the time limits established hereinabove may result in the Contractor becoming

liable to the District for non-performance penalties per Exhibit C, Section 4.

- D. The above provisions shall not be construed to eliminate the Contractor's responsibility for complying with the requirement to notify the Director for additional maintenance as set forth herein.
- E. When inclement weather renders performance per approved schedule unsafe, impractical, or liable to damage landscaping, the Contractor shall adjust his work force in order to accomplish those work items not affected by weather, and shall contact District field staff to inform them of said alternate work assignments. Failure to advise the District may be cause for assessment of non-performance penalties per Exhibit C, Section 4.
- F. For the purposes of this Contract, "Working Days" shall be Mondays through Thursdays, excluding holidays as provided herein. The hours of maintenance service shall be from 7:00 a.m. to 4:30 p.m. on those days maintenance is to be provided pursuant to the work schedule as approved by the Director. Any work the Contractor proposes to perform outside of the days and hours set forth hereinabove, as well as on legal City holidays, shall not be undertaken without the prior written approval of the Director.

The following days have been designated as holidays by the City:

New Year's Day	January 1
Martin Luther King Jr. Day	3rd Monday in January
President's Day	3rd Monday in February
Memorial Day	Last Monday in May
Independence Day	July 4
Labor Day	1st Monday in September
Veteran's Day	November 11
Thanksgiving Day	4th Thursday in November
Day after Thanksgiving	4th Friday in November
Christmas Eve	December 24
Christmas Day	December 25

If a holiday falls upon a Sunday, the following Monday shall be the day the holiday is observed. If a holiday falls upon a Saturday, the preceding Friday shall be the day the holiday is observed. If a scheduled maintenance service day falls on a designated holiday, the Contractor shall submit a proposed make-up day for the Director's approval.

3. FUNCTIONS AND RESPONSIBILITIES

- A. The Director and Contractor shall conduct an inspection of all sites covered under this Contract as soon as practicable after its execution, and prior to commencement of Contractor's operations. This shall include but not be limited to the nature and extent of any deficiencies noted by the Contractor, and acknowledged by the Director. The Contractor is hereby advised that this review

shall serve as the benchmark for the Director's evaluation of Contractor's performance under this Contract. Failure to perform services as required shall result in the District deducting payment in full or part of the Contractor's compensation, as further described in Exhibit C., Section 3.

- B. The Contractor or any subcontractors working under Contractor's direction and control must observe all restrictions on the unauthorized take of migratory birds, as set forth in the U.S. Fish and Wildlife Service Migratory Bird Treaty Act (MBTA), including but not limited to Sections 703-713 and the California Department of Fish and Game Code Sections 3503, 3503.5, and 3513.
- C. The Contractor shall on an ongoing basis maintain a monthly log that records all work performed by the Contractor. Said log shall be in a form and content acceptable to the Director (see Appendix B, Monthly Report Form), and shall be submitted to the Director by the tenth day of each month, one (1) month in arrears. The monthly payment for the work so reported will not be authorized until such report (Monthly Report) is received, and approved by the Director.
- D. The Contractor shall maintain an office at some fixed place, and shall maintain an operable telephone thereat, listed in the telephone directory in Contractor's own name or in the Contractor's company name, and shall at all times employ some responsible person(s) to take the necessary action regarding all inquiries, complaints, and/or emergency calls that may be received from the Director or other authorized individuals or agencies as listed in Exhibit A, Section 3., paragraph F. This person(s) shall be reachable twenty-four (24) hours per day, seven (7) days a week. During normal working hours, the Contractor's Supervisor or employee designated as being responsible for providing maintenance services to the District shall be directly available for immediate notification through some type of reliable electronic means, including but not limited to, mobile or cellular phone, two-way radio, or pager. The Contractor or Contractor's designated employee shall confirm said notification within one (1) hour of receipt. An answering service will be considered an acceptable substitute for coverage only during periods outside of normal working hours, provided Contractor is advised of emergency calls within one (1) hour of receipt of the call by the answering service and within twenty-four (24) hours after receipt of non-emergency calls by the answering service. The above provision for Contractor's communication with the District is the minimum acceptable standard under this Contract. Failure to regularly provide said communication capability may result in the Contractor being assessed non-performance penalties, per Exhibit C., Section 4.
- E. The Contractor shall respond to an emergency call from any of the parties listed below no later than two (2) hours following first notification by facsimile transmission, or in writing, or by telephone. In situations involving emergency repair work after normal working hours, the Contractor shall dispatch qualified personnel, and equipment to reach the site within two (2) hours of first notification. An emergency may be called by the following individuals or agencies at any time:

1. City Manager

5. Special Districts Division Manager

2. Director of Public Works
3. Police Department
4. Fire Department
6. Street Maintenance Supervisor
7. Senior Landscape Services Inspector
8. Landscape Services Inspector

Contractor's emergency response and any necessary corrective work shall be considered Additional Work as defined in Exhibit C., Section 2, unless said emergency is determined to have been caused by an act or omission attributable to the Contractor.

4. CONTRACTOR'S STAFF

- A. The Contractor shall provide sufficient personnel to perform all work in accordance with the Specifications set forth herein. All of the Contractor's maintenance personnel shall be supervised at the work site(s) by a qualified Supervisor in the employ of the Contractor. Work Site Supervisors must be able to demonstrate to the satisfaction of the Director that they possess adequate technical background, and communication skills to perform the intended services. Adequate and competent supervision shall be provided for all work done by the Contractor's employees to ensure accomplishment of high quality work, which will be acceptable to the Director. Any order or communication given to the Work Site Supervisor shall be deemed to have been delivered to the Contractor.
- B. The Contractor and his employees and subcontractors, if any, shall conduct themselves in a proper, professional, and efficient manner at all times, and shall cause the least possible inconvenience to the public.
- C. The Director may require the Contractor to remove from the work site any employee(s) deemed careless, incompetent, or otherwise objectionable, whose continued employment on the job is considered to be contrary to the best interests of the District.
- D. The Contractor shall require each employee performing work under the Contract to adhere to basic public works standards of working attire, including but not limited to wearing of proper clothing, proper shoes, and other gear required by applicable Safety Regulations and/or fertilizer/pesticide label requirements.

Shirts shall be worn at all times, and shall be buttoned. Approved safety vests shall be worn by Contractor's employees when working on parkway medians, monuments, parkways, and other high traffic-hazard areas as determined by the Director. Failure to comply with the above requirements may make the Contractor liable for assessment of non-performance penalties, per Exhibit C., Section 4.

- E. The Contractor shall establish an identification system for Contractor's personnel which clearly indicates to the public the name of the Contractor. The identification system shall be furnished at the Contractor's expense and may include appropriate attire, and/or name badges as specified by the Director.

5. EMPLOYMENT OF APPRENTICES

The provisions of Sections 1777.5, 1777.6, and 1777.7 of the California Labor Code regarding the employment of properly registered apprentices may apply to this Contract if the Contractor, or any subcontractors thereunder, employs workers in any apprentice able craft or trade. It is the Contractor's sole responsibility to comply with the Labor Code sections cited above. Information relative to apprenticeship standards, wage schedules, and other requirements may be obtained from the California Department of Industrial Relations.

6. COMPLAINTS

- A. All complaints shall be responded to as soon as possible after notification, but in all cases within twenty-four (24) hours, to the satisfaction of the Director. If any complaint is not satisfactorily responded to within twenty-four (24) hours, the Director shall be notified immediately of the reason for not remedying the complaint followed by a written report to the Director within five (5) working days. If the complaints are not remedied within the time specified, and to the satisfaction of the Director, the Director may correct the specific complaint by using an alternative source. The total cost incurred by the District to effect necessary remedies will be deducted from the payments owing to the Contractor from the District, per Exhibit C., Section 3.
- B. The Contractor shall maintain a written log of all complaints, the date and time thereof, and the action taken pursuant thereto, or the reason for non-action. Said log shall be submitted to the Director monthly as set forth in Section 3, paragraph C. above.
- C. In addition to the provisions of Section 6., paragraph A. above, in the event of a failure by the Contractor to satisfactorily remedy a complaint in a timely manner or for any other breach of this Contract by Contractor, the District may immediately upon written notice to the Contractor terminate this Contract.

7. SAFETY

- A. The Contractor agrees to perform all work as outlined in the Provisions listed herein in such a manner as to meet all accepted standards for safe practices and to safely maintain equipment, machines, and materials, and prescribe and employ all precautions and safety procedures related to other hazards consequential to the work; and accepts additionally the sole responsibility for complying with all local, State, Federal and other legal requirements including but not limited to, full compliance with the terms of any and all applicable OSHA and Cal/OSHA Safety Orders at all times so as to protect all persons, including Contractor's employees and subcontractors, agents of the District, City, materialmen, vendors, members of the public and others from foreseeable injury, or damage to their property.
- B. The Contractor's operations shall be conducted in such a manner as to cause the least possible obstruction, and inconvenience to public traffic. The Contractor shall furnish, erect and maintain such fences, barriers, lights and warning signs as may be deemed necessary by the Director, or any duly constituted public safety official.

Contractor's work area traffic control, including but not limited to type and placement of signs, barricades, and delineators, shall be in accordance with the "Manual of Uniform Traffic Control Devices, 2010 (or most current) California Supplement".

Contractor's work should not encroach into open lanes of traffic between the hours of 7:00 a.m. and 8:30 a.m., or between the hours of 3:30 p.m. and 6:00 p.m.

- C. The Contractor shall maintain all work sites free of hazards to persons or property resulting from Contractor's operations. The Contractor shall inspect for all potential hazards at said areas under maintenance, and keep a log indicating date inspected, and action taken. Said log shall be submitted to the Director monthly as set forth in Section 3, paragraph C. above. Any hazardous condition noted by the Contractor, which is not a result of Contractor's operations, shall be immediately reported to the Director.
- D. The Contractor shall be responsible for making minor corrections, including but not limited to, filling holes in turf areas, replacing valve box covers, and repairing irrigation systems, so as to protect members of the public or others from injury.

The Contractor shall cooperate fully with the District or City in the investigation of any accidental injury or death occurring on the site, including a complete written report thereof to the Director within five (5) working days following the occurrence.

- E. Failure to comply with the provisions of this section of Exhibit A may result in: payment deduction per Exhibit C, Section 3 of the Contract, or assessment of non-performance penalties per Exhibit C., Section 4. Repeated failure to comply with the provisions of this section may result in contract termination, per Exhibit A, Section 3, paragraph J of the Independent Contract Agreement.

8. ESTIMATED QUANTITIES

The estimated quantities given in the Bid Schedule are approximate only, being given as a basis for the comparison of bids. The District does not expressly or by implication, agree that the actual amount of work will correspond therewith, and reserves the right to increase or decrease the amount of any portion of the work, or to omit portions of the work, or delete any bid items or work, as may be deemed necessary or advisable by the Director.

9. NATIONAL POLLUTANT DISCHARGE ELIMINATION SYSTEM (NPDES) PERMIT - REQUIRED URBAN RUNOFF MANAGEMENT TRAINING

The Contractor shall provide National Pollutant Discharge Elimination System (NPDES) Permit training for Urban Runoff Management to Contractor's employees and subcontractors if any. Failure to provide Urban Runoff Management training is a violation of Order No. R8-2002-0011, NPDES No. CAS 618033 (Municipal Separate Storm Sewer System NPDES Permit), Section XI.I, for each day of which such failure occurs, and shall in addition, be a breach of the Contract with the City of Moreno Valley (City). Contractor understands and agrees that NPDES Permit violations are grounds for enforcement action by the

Environmental Protection Agency, the State/Regional Water Resources Control Board, and the City and may result in permit termination (stop work order), civil and criminal fines, and termination of Contract. By submitting a proposal, the Contractor certifies to the City that Contractor's employees and subcontractors, if any, have been trained for Urban Runoff Management, and sufficient sums are included in the proposal's amount to cover costs of such said training.

10. LICENSES AND PERMITS

The Contractor shall, without additional expense to the District or City, possess all licenses and permits, including but not limited to a valid City Business License, required for the performance of the work under this Contract.

11. PREVAILING WAGE

- A. Pursuant to provision of Section 1773 of the Labor Code of the State of California, the Moreno Valley Community Services District has obtained the general prevailing rate of per diem wages applicable for the work to be done, including but not limited to: straight time, overtime and holiday work; travel and subsistence payments; employee payments of health and welfare, vacation, pension, and similar purposes. Said rate and scale are on file with the Public Works Department of the City of Moreno Valley, and copies will be made available to any interested party on request. These rates shall be the minimum wage rates for this project. Throughout the term of this Contract, the Contractor will be required to post a copy of said rate, and scale as required by the Labor Code.
- B. Pursuant to provisions of Section 1775 of the Labor Code, the Contractor shall forfeit as penalty to the Moreno Valley Community Services District, not more than fifty dollars (\$50.00) for each laborer, workman, or mechanic employed for each calendar day or portion thereof, if such laborer, workman, or mechanic is paid less than the general prevailing rate of wages hereinabove stipulated for any work done under the attached contract, by the Contractor or by any subcontractor under Contractor's direction and control, in violation of the provisions of said Labor Code.

12. PAYROLL RECORDS

- A. The Contractor, and any subcontractor thereunder, shall keep complete and accurate payroll records for each workman employed by Contractor/subcontractor in connection with this Contract, as required by California Labor Code Section 1776.
- B. The Contractor, and any subcontractor thereunder, shall make available to the District upon its request certified payroll records for each workman employed in connection with this contract as required by California Labor Code Section 1776.
- C. The District may withhold from Contractor's progress payments the penal sum of twenty-five dollars (\$25.00) per calendar day (or portion thereof) for each worker employed in connection with this Contract should Contractor, or any subcontractors thereunder, fail to strictly comply with California Labor Code 1776 after receiving written notice of non-compliance.

13. BONDS

Pursuant to Section 3247 of the Civil Code, the Contractor hereby agrees to provide and maintain in full force and effect for the duration of this Contract, two (2) good, and sufficient surety bonds, to wit:

- A. A "Faithful Performance Bond" in the amount of one hundred percent (100%) of the contract price, which shall guarantee the faithful performance of all work, and;
- B. A "Materials and Labor Bond" in the amount of one hundred percent (100%) of the contract price, which shall secure the payment of the claims of labor, mechanics or materialmen for all work performed hereunder.

14. SUBSTITUTION OF SECURITIES

Pursuant to California Public Contract Code Section 22300, the Contractor will be permitted the substitution of securities for any monies withheld by the Moreno Valley Community Services District to ensure performance under Contract. At the request and expense of the Contractor, securities equivalent to the amount withheld shall be deposited with the Moreno Valley Community Services District, or with a state or federally chartered bank as the escrow agent, who shall pay such monies to the Contractor. Securities eligible for substitution under this section shall include those listed in Section 16430 of the Government Code, bank or savings and loan certificates of deposit, interest-bearing demand deposit accounts, and standby letters of credit. The Contractor shall be the beneficial owner of any securities substituted for monies withheld, and shall receive any dividends or interest thereon. The Contractor shall give the District written notice within thirty (30) days after the Contract is awarded that it desires to substitute securities for money that would ordinarily be withheld. If the substituted securities are deposited into an escrow, the escrow shall be governed by a written escrow agreement in a form which is substantially similar to the agreement set forth in Section 22300 of the Public Contract Code.

15. CONTRACTOR'S LIABILITY

- A. The Contractor shall be responsible for all damages to people and/or property that occur as a result of the fault or negligence attributable to Contractor in connection with the performance under this Contract. Any and all restitution or repairs deemed necessary by the Director to remedy such damages shall be furnished and performed at the Contractor's sole expense, and shall be completed within the time limits established by the Director.
- B. Repairs made to sites and site appurtenances that are damaged as a result of Acts of Nature, vandalism, theft, and acts or omissions by third parties or any other occurrence not attributable to the Contractor's operations shall be repaired by the Contractor as Additional Work and compensated as defined in Exhibit C., Section 2.

16. CONTRACTORS LICENSE

Contractors are required by law to be licensed, and regulated by the Contractors' State License Board. Contractor will comply with all applicable licensing laws, and regulations. Any questions concerning a Contractor may be referred to the Registrar, Contractors' State License Board, 9821 Business Park Driver, Sacramento, CA 95827. Mailing address: P.O. Box 26000, Sacramento, CA 95826.

17. TECHNICAL PROVISIONS

A. TREE CARE

1. All trees are to be maintained in a manner that will promote normal, healthy growth.
2. Whenever site conditions permit, trees are allowed to grow to assume their full, natural shape, with the minimum trimming/pruning necessary to assure public safety and tree survival. All tree trimming/pruning shall be done in conformance with ANSI 300-2001, (or most current revision); safety requirements will be per ANSI Z133-1994 (or most current revision) standards. Failure to adhere to this specification without the Director's approval may result in the assessment of non-performance penalties, per Exhibit C., Section 4.
3. Trees shall be pruned as identified and requested in order to:
 - (a) Remove dead, diseased, or damaged branches:
 - (b) Remove unwanted encroachments into the public and/or utility rights-of-way;
 - (c) Correct any condition which the Director has deemed to be hazardous.
4. Trees up to eighteen feet (18') in height shall:
 - (a) Be pruned to enable successful adaptation to their particular site situation;
 - (b) Have no more than one-third (1/3) of living branches removed annually;
 - (c) Be fertilized only as directed by District field staff.
5. Trees over eighteen feet (18') in height shall:
 - (a) Pruned and/or trimmed as necessary to maintain proper site orientation;
 - (b) Pruned and/or trimmed as necessary to remove unwanted encroachments into public, and/or utility rights-of-way;

- (c) Pruned and/or trimmed as necessary to correct any condition which the Director has deemed to be hazardous.
- 6. Trimming/pruning tools shall:
 - (a) Be kept properly sharpened and in proper working order.
 - (b) Be sterilized with five percent (5%) chlorine bleach and water solution before commencing work and between any cuts on any tree known to be diseased.
- 7. The following practices shall not be allowed:
 - (a) Internodal cuts of any kind (a.k.a. "stubbing", "shearing", "tipping" or "topping").
 - (b) Cuts made flush with the trunk or branch. The integrity of the branch collars must be maintained at all times.
 - (c) Use of pruning paint/pruning compound/wound dressing.
 - (d) Use of climbing spurs or gaffs.
- 8. Trees shall be staked/guyed in a manner, and with materials that are acceptable to the Director. Double staking with two (2) lodge pole-type stakes is the minimum District standard.
- 9. Tree stakes, tree ties, and guy wires shall be inspected regularly to ensure against girdling and abrasion, and removed as soon as possible after tree establishment, and site conditions allow.

B. DEBRIS/LITTER

- 1. After pruning, trimming, or other work as required under this Contract, the Contractor shall remove immediately from the site all debris generated as a result of the operations to prune, trim or provide other work as required under this Contract and in the performance of the Contractor's work, and dispose of such debris in a legal manner.
- 2. All hardscape areas, including but not limited to sidewalks, curbs, and gutters shall be maintained in a hazard-free condition.
- 3. From time to time the Director may require Contractor to perform Special Clean-Ups on a site-specific basis. Said Special Clean-Ups shall be considered Additional Work per Exhibit C., Section 2.
- 4. The Contractor shall dispose of all debris and litter, as described in paragraphs 1 and 2 above, off-site, and in a legal manner.
- 5. The Contractor shall notify the Director immediately whenever suspicious and/or hazardous waste materials are discovered within service area sites.

Such materials may include, but are not limited to: discarded motor oil, or other petroleum-based liquids; paint; chemical compounds, including but not limited to pesticides, both liquid and dry; any unknown liquid or dry material in an unmarked container; household appliances; household electronic devices, including but not limited to, televisions, computers and computer monitors; firearms or ammunition. Any such articles shall not be touched, handled, or in any way disturbed or moved from the location where they were discovered. Contractor's staff shall secure the area against entry by any third party until District staff arrives at the site.

6. Failure to adhere to the specifications of this section of the Special Provisions may result in the assessment of non-performance penalties, per Exhibit C., Section 4.

C. GREENWASTE RECYCLING

1. The Public Resources Code (PRC), Division 30, Sections 41000 through 41780 requires that the City of Moreno Valley divert from landfills fifty percent (50%) of the solid waste, including greenwaste, generated within its jurisdiction.
2. For the purposes of this contract, materials defined as "greenwaste" shall include all tree and plant parts (e.g., trimmings, prunings, etc.) removed from contract sites by the Contractor, or any subcontractors thereunder, in performance of contract's Scope of Work.
3. Contractor, or any subcontractor thereunder, shall deposit all greenwaste generated in performance of contract's Scope of Work at a landscape material recycling center, or reuse said greenwaste in some manner. Contractor, or any subcontractor thereunder, shall be solely responsible for all costs incurred in complying with this requirement.
4. The Contractor shall submit a Monthly Greenwaste Report (see Appendix C) as an element of Contractor's Monthly Report, as set forth in Section 3. – Functions and Responsibilities. The Contractor shall provide responses to all information requested therein and shall include, on a separate Monthly Greenwaste Report form, any greenwaste generated through the operations of any subcontractors performing under Contractor's Scope of Work.
5. Failure to adhere to the specifications of this section of the Special Provisions may result in the assessment of non-performance penalties, per Exhibit C., Section 4.

18. PROJECT LOCATION MAPS

Moreno Valley Community Services District Extensive Landscape Maintenance (*Jardineria y mantenimiento general*)

Zone (Zona) E-1 • Towngate

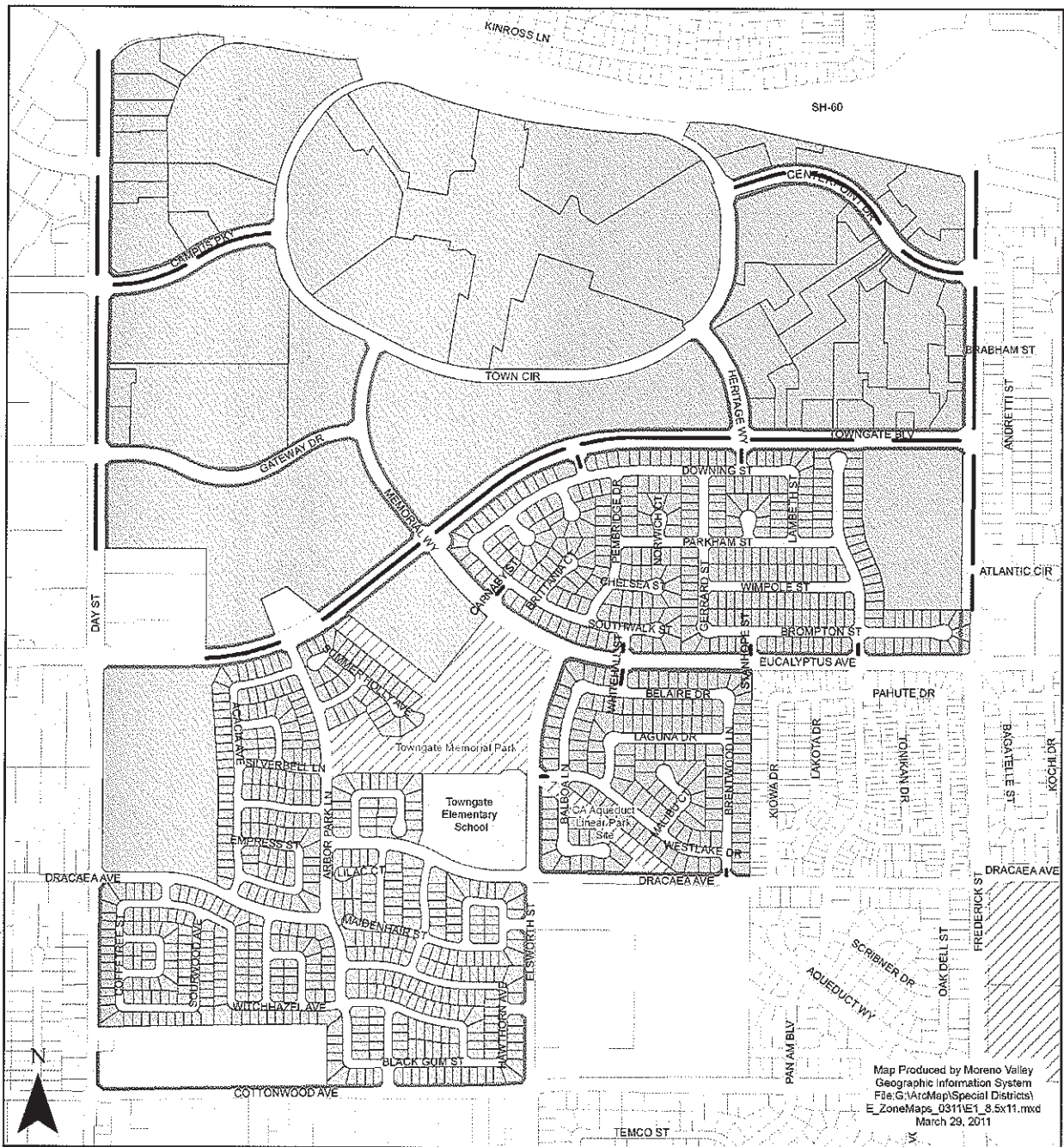

The information shown on this map was compiled from the Riverside County GIS and the City of Moreno Valley GIS. The land shape and facility information on this map is for display purposes only and should not be relied upon without independent verification as to its accuracy. Data and information on this map is subject to update and modification. Riverside County and City of Moreno Valley will not be held responsible for any claims, losses or damages resulting from the use of this map. This map is not to be recycled or resold.

- Landscaped Median (*Medianas Ajardinadas*)
- Landscaped Parkway (*Areas Ajardinadas*)
- Zone E-1 Parcels (*Zona E-1 Parcelas*)



Moreno Valley Community Services District Extensive Landscaping & Irrigation

Zone E-1A • Walls/Internal Landscape Maintenance



The information shown on this map was compiled from the Riverside County GIS and the City of Moreno Valley GIS. The land base and facility information on this map is for display purposes only and should not be relied upon without independent verification as to its accuracy. Data and information on this map is subject to update and modification. Riverside County and City of Moreno Valley will not be held responsible for any claims, losses or damages resulting from the use of this map. This map is not to be recycled or resold.

- CSD Maintained Aterial Walls
- CSD Maintained Landscape and Internal Walls
- Zone E-1A Parcels



Moreno Valley Community Services District Extensive Landscape Maintenance (*Jardinaria y mantenimiento general*)

Zone (Zona) E-2 • Hidden Springs

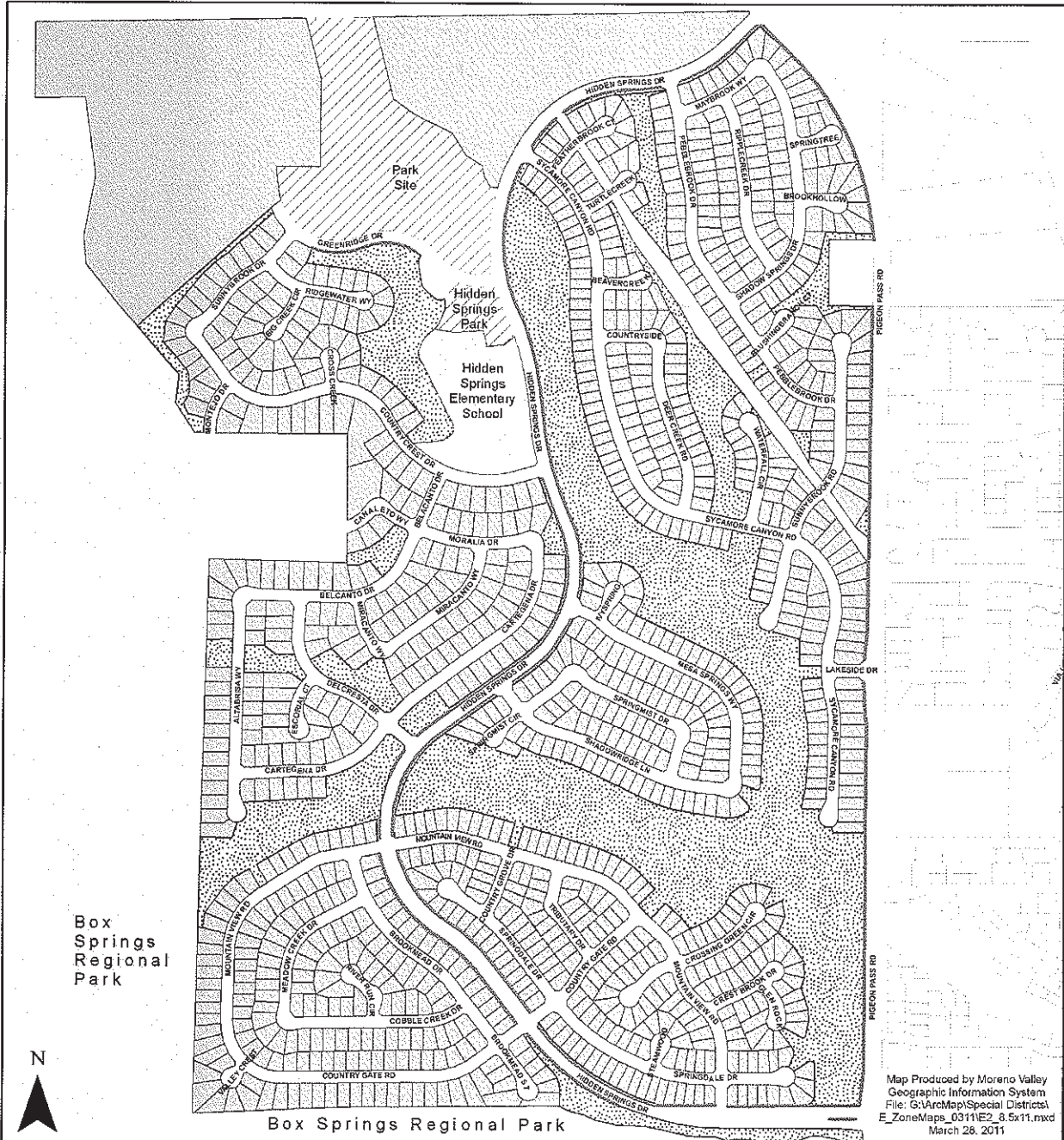

The information shown on this map was compiled from the Riverside County GIS and the City of Moreno Valley GIS. The land base and facility information on this map is for display purposes only and should not be relied upon without independent verification as to its accuracy. Data and information on this map is subject to update and modification. Riverside County and City of Moreno Valley will not be held responsible for any claims, losses or damages resulting from the use of this map. This map is not to be recycled or resold.

- Landscaped Parkway (*Areas Ajardinadas*)
- Landscaped Open Space (*Area abierta Ajardinada*)
- Zone E-2 Properties (*Zona E-2 Propiedades*)



Moreno Valley Community Services District Extensive Landscaping & Irrigation

Zone E-3 • Moreno Valley Ranch - West

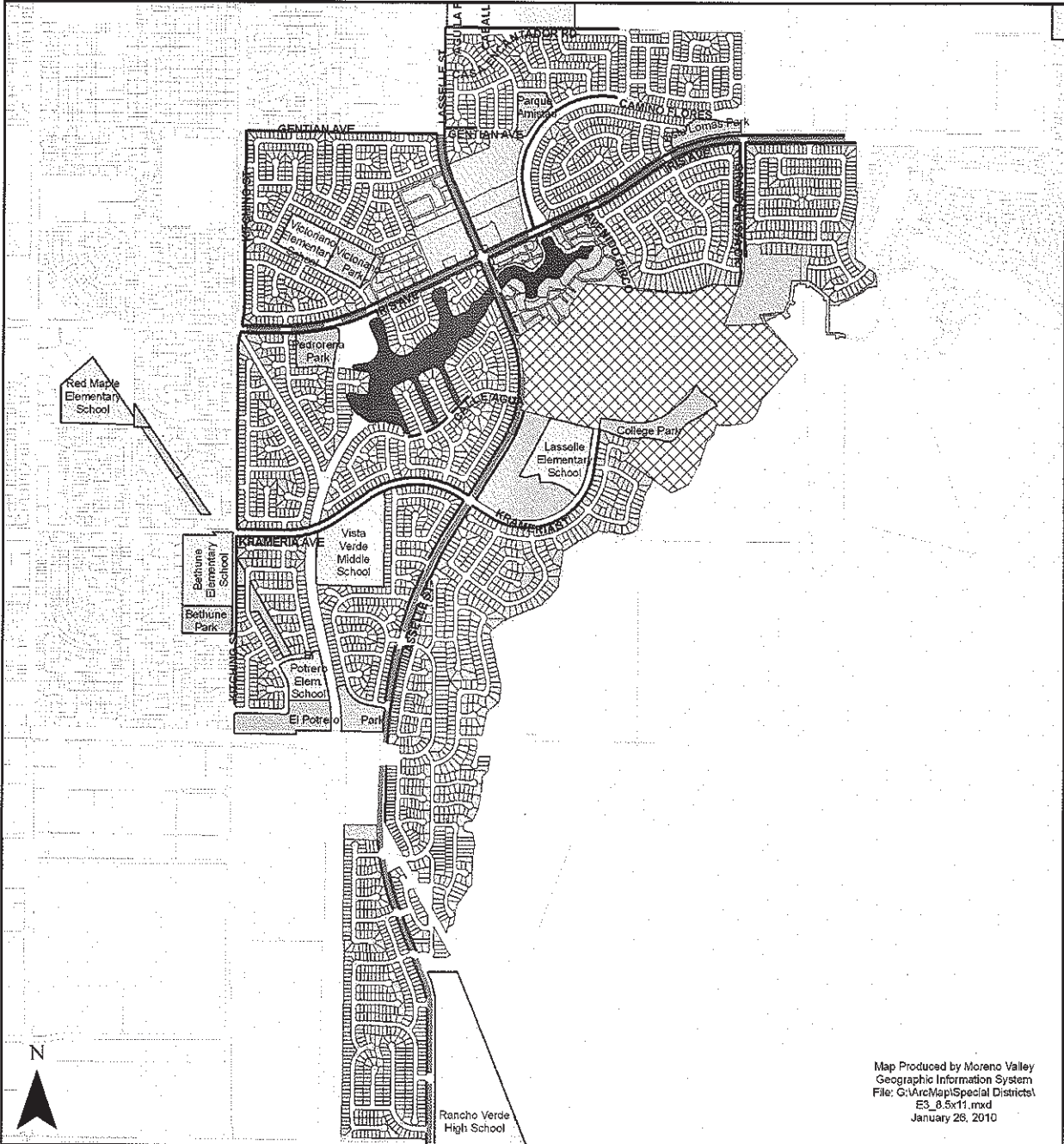

The information shown on this map was compiled from the Riverside County GIS and the City of Moreno Valley GIS. The land base and facility information on this map is for display purposes only and should not be relied upon without independent verification as to its accuracy. Data and information on this map is subject to update and modification. Riverside County and City of Moreno Valley will not be held responsible for any claims, losses or damages resulting from the use of this map. This map is not to be recycled or resold.

- Landscaped Parkway
- Medians
- Not Part of Zone E-3
- Zone E-3 Parcels

Map Produced by Moreno Valley
Geographic Information System
File: G:\ArcMap\Special Districts\
E3_8.5x11.mxd
January 28, 2010



Moreno Valley Community Services District Extensive Landscape Maintenance (*Jardineria y mantenimiento general*)

Zone (Zona) E-4 • Moreno Valley Ranch - East (Este)

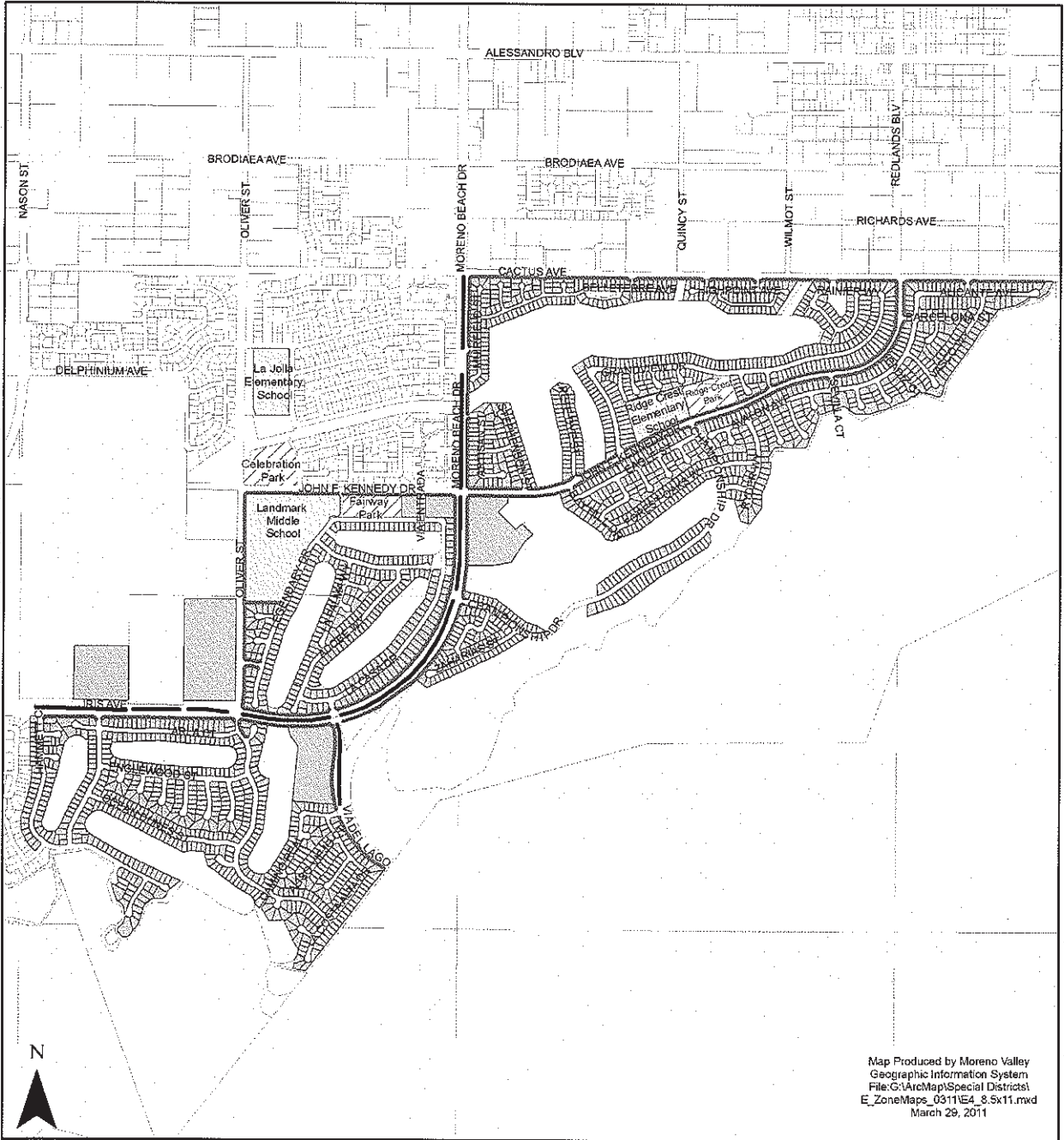

The information shown on this map was compiled from the Riverside County GIS and the City of Moreno Valley GIS. The land base and facility information on this map is for display purposes only and should not be relied upon without independent verification as to its accuracy. Data and information on this map is subject to update and modification. Riverside County and City of Moreno Valley will not be held responsible for any claims, losses or damages resulting from the use of this map. This map is not to be recycled or resold.

- Landscaped Parkway (*Areas Ajardinadas*)
- Landscaped Median (*Medianas Ajardinadas*)
- Zone E-4 Parcels (*Zona E-4 Parcelas*)

Map Produced by Moreno Valley
Geographic Information System
File: G:\ArcMap\Special Districts\
E_ZoneMaps_0311\E4_8.5x11.mxd
March 29, 2011



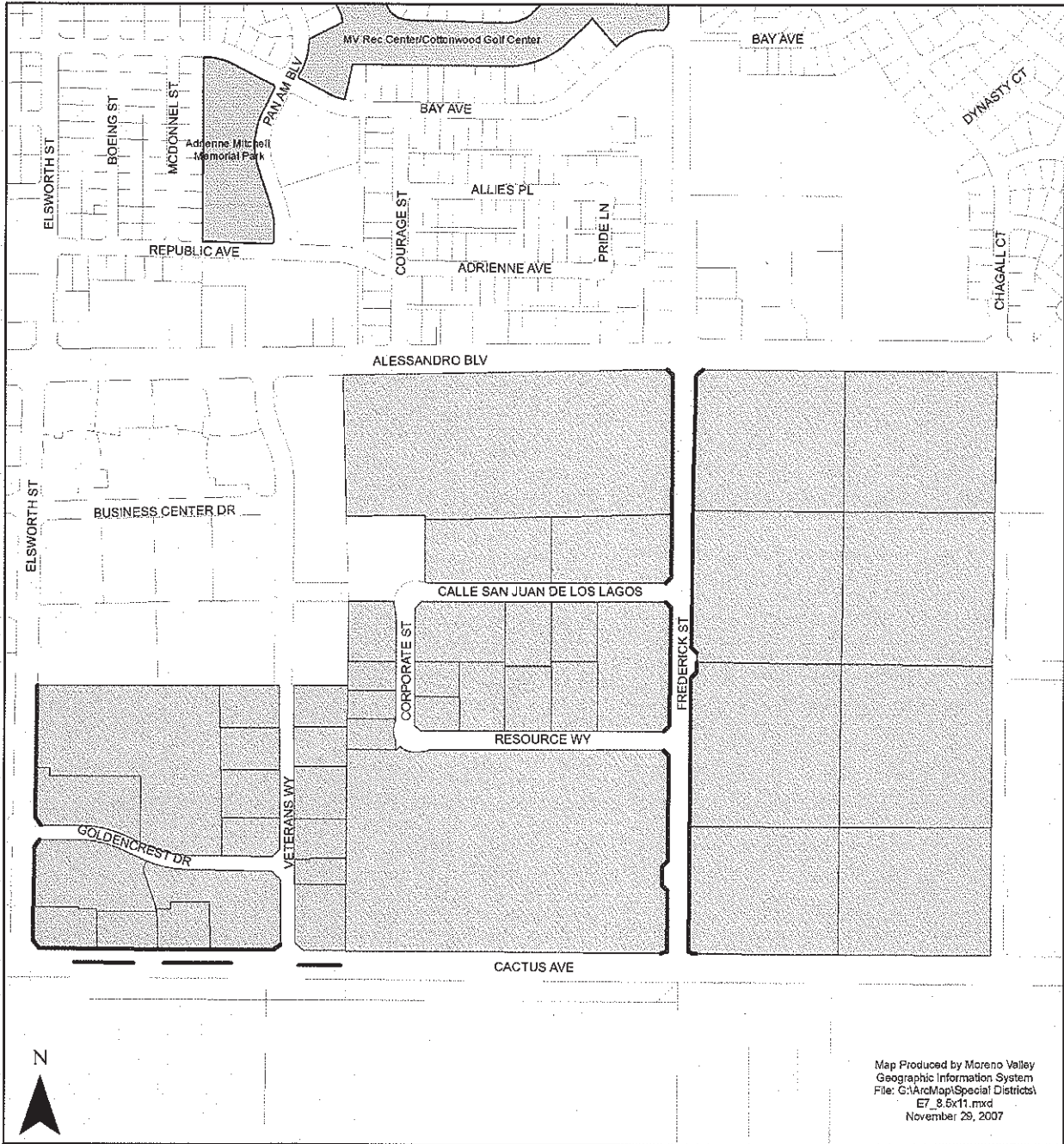

Moreno Valley Community Services District Extensive Landscaping & Irrigation

Zone E-7 • Centerpointe



The information shown on this map was compiled from the Riverside County GIS and the City of Moreno Valley GIS. The land base and facility information on this map is for display purposes only and should not be relied upon without independent verification as to its accuracy. Date and information on this map is subject to update and modification. Riverside County and City of Moreno Valley will not be held responsible for any claims, losses or damages resulting from the use of this map. This map is not to be recycled or resold.

-  Landscaped Median
-  Landscaped Parkway
-  Zone E-7 Parcels



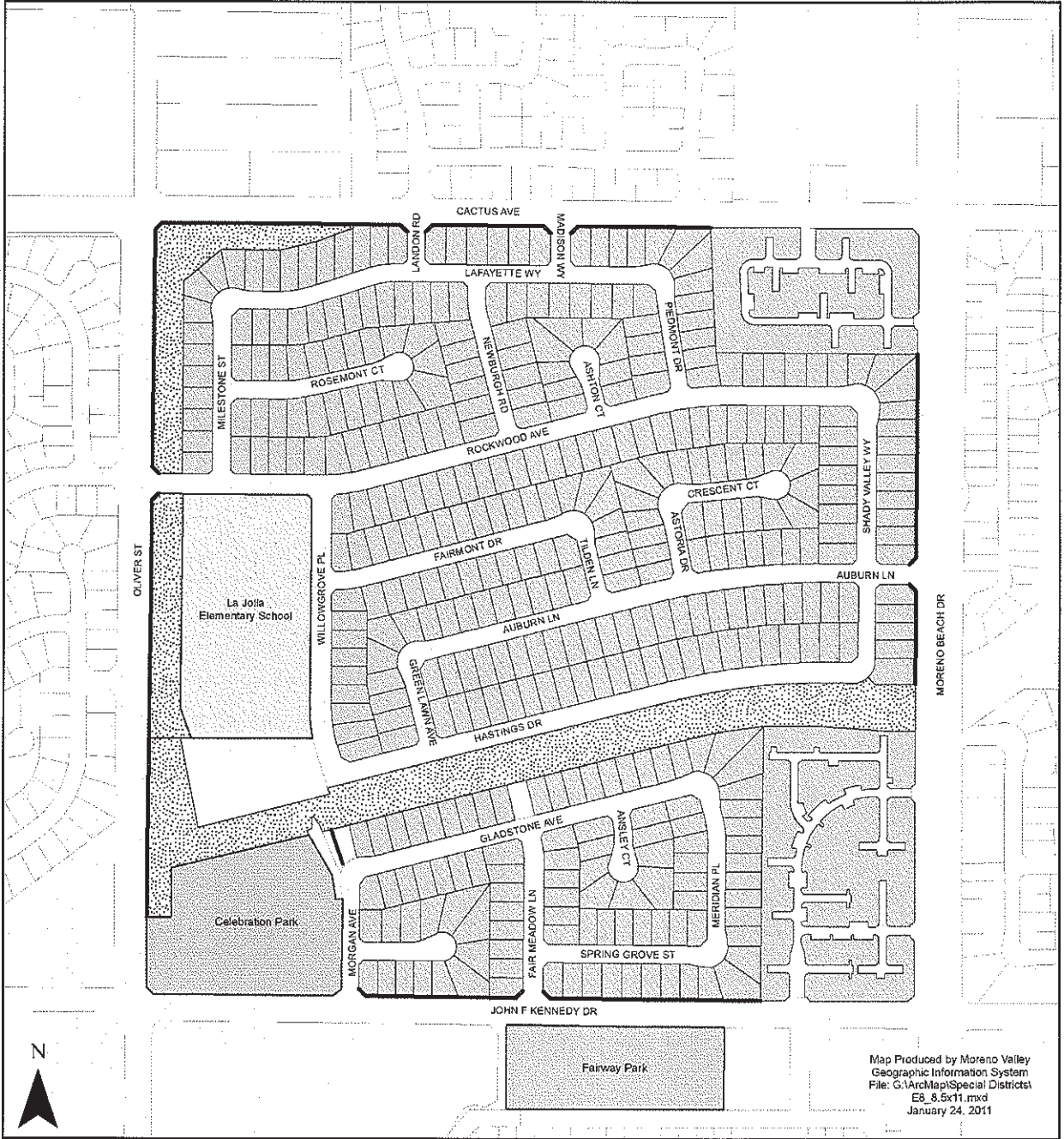

Moreno Valley Community Services District Extensive Landscaping & Irrigation

Zone E-8 • Promontory Park



The information shown on this map was compiled from the Riverside County GIS and the City of Moreno Valley GIS. The land base and facility information on this map is for display purposes only and should not be relied upon without independent verification as to its accuracy. Data and information on this map is subject to update and modification. Riverside County and City of Moreno Valley will not be held responsible for any claims, losses or damages resulting from the use of this map. This map is not to be recycled or resold.

-  Landscaped Parkway
-  Landscaped Open Space
-  Zone E-8 Parcels

Map Produced by Moreno Valley
Geographic Information System
File: G:\ArcMap\Special Districts
E8_8.5x11.mxd
January 24, 2011





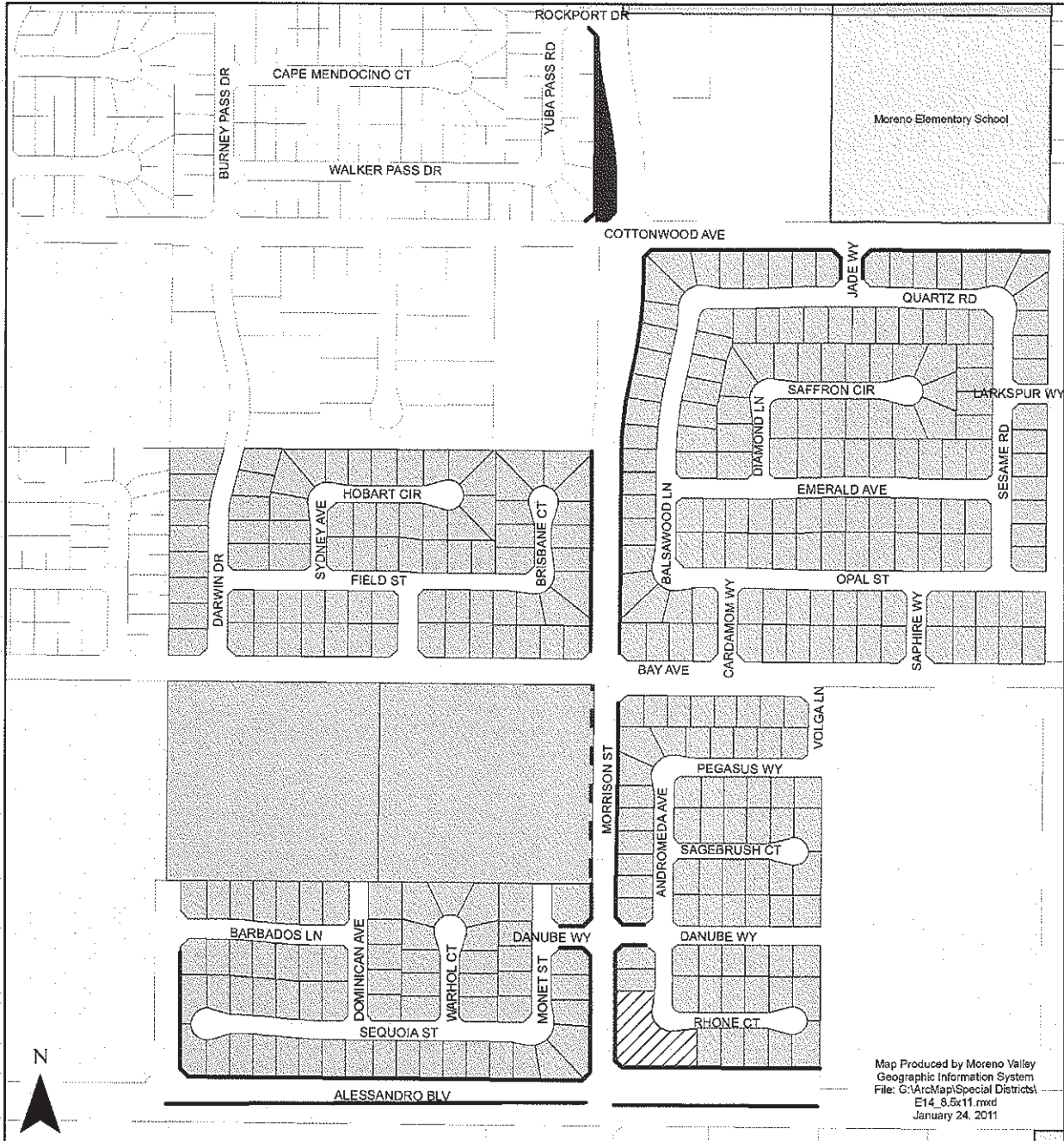

Moreno Valley Community Services District Extensive Landscaping & Irrigation

Zone E-14 • Mahogany Fields

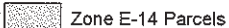

Map Produced by Moreno Valley
Geographic Information System
File: G:\ArcMap\Special Districts
E14_8.5x11.mxd
January 24, 2011

The information shown on this map was compiled from the Riverside County GIS and the City of Moreno Valley GIS. The land base and facility information on this map is for display purposes only and should not be relied upon without independent verification as to its accuracy. Data and information on this map is subject to update and modification. Riverside County and City of Moreno Valley will not be held responsible for any claims, losses or damages resulting from the use of this map. This map is not to be recycled or resold.

-  Landscaped Parkway
-  Future Landscaping
-  Landscaped Median
-  Zone E-14 Parcels
-  Not Part Of E-14 Landscaping
-  Turf Area





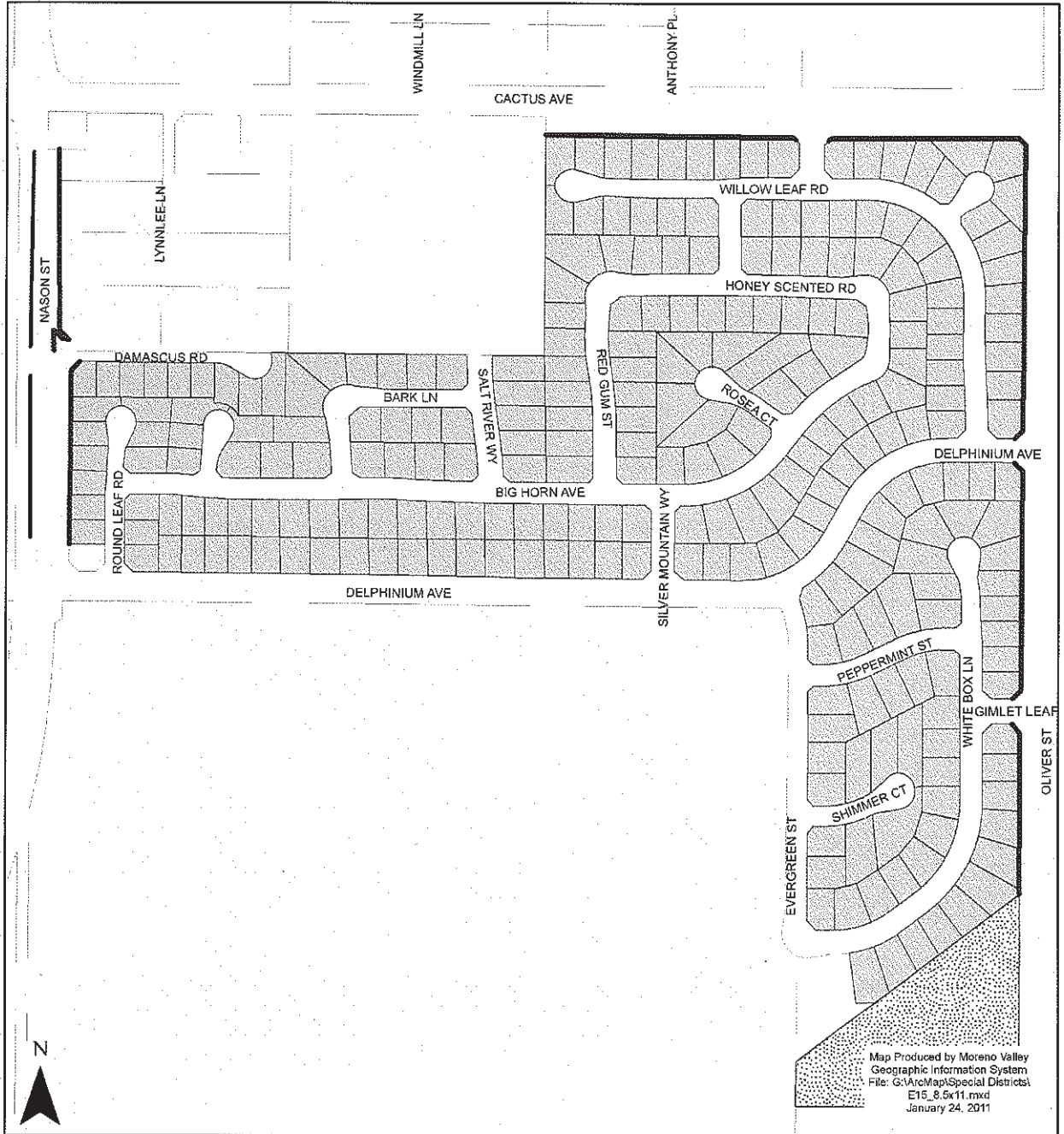

Moreno Valley Community Services District Extensive Landscaping & Irrigation

Zone E-15 • Celebration



Map Produced by Moreno Valley
Geographic Information System
File: G:\ArcMap\Special Districts\
E15_8.5x11.mxd
January 24, 2011

The information shown on this map was compiled from the Riverside County GIS and the City of Moreno Valley GIS. The land base and facility information on this map is for display purposes only and should not be relied upon without independent verification as to its accuracy. Data and information on this map is subject to update and modification. Riverside County and City of Moreno Valley will not be held responsible for any claims, losses or damages resulting from the use of this map. This map is not to be recycled or resold.

-  Landscaped Parkway
-  Landscaped Median
-  Landscaped Open Space
-  Zone E-15 Parcels



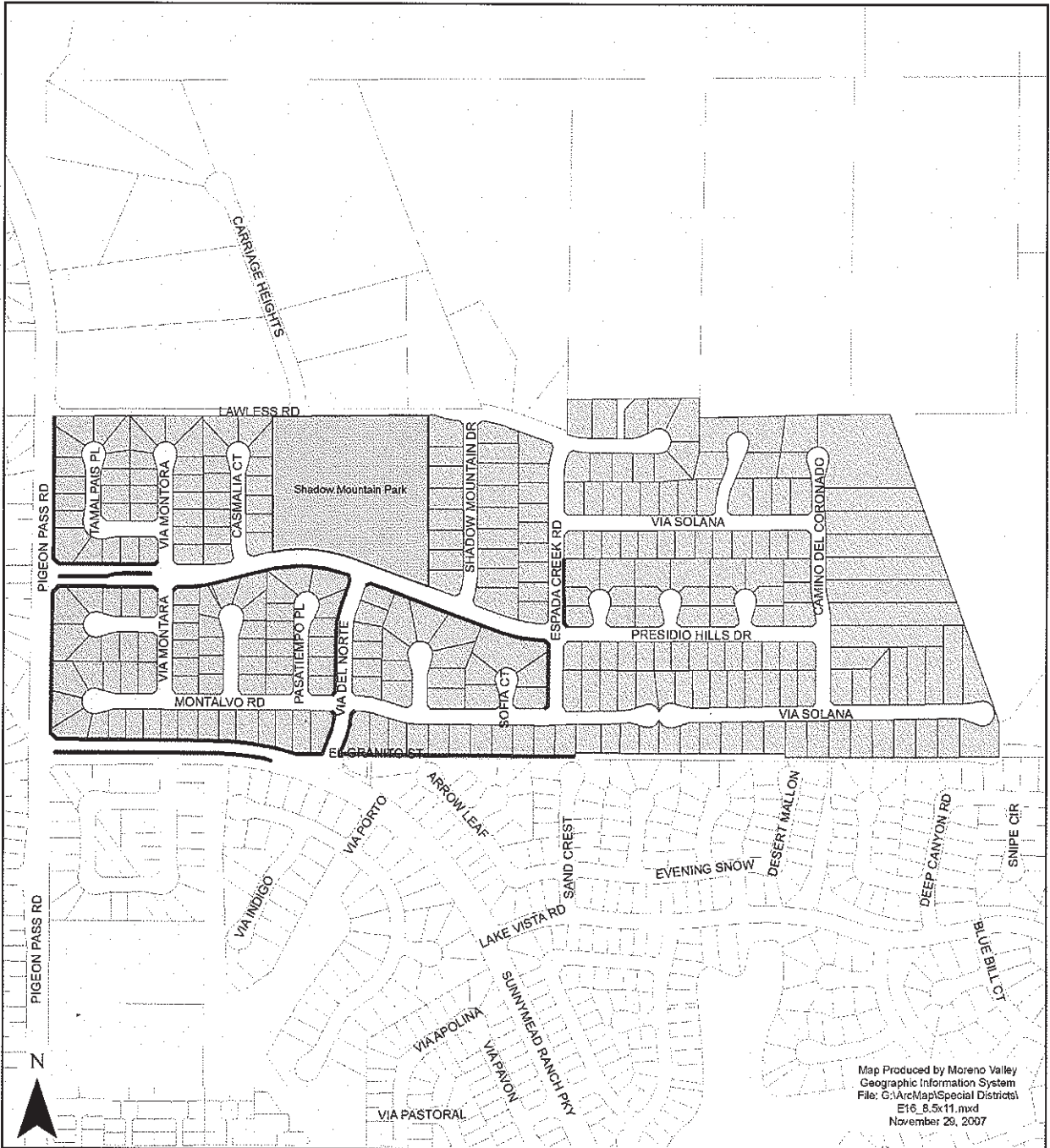

Moreno Valley Community Services District Extensive Landscaping & Irrigation

Zone E-16 • Shadow Mountain



The information shown on this map was compiled from the Riverside County GIS and the City of Moreno Valley GIS. The land base and facility information on this map is for display purposes only and should not be relied upon without independent verification as to its accuracy. Data and information on this map is subject to update and modification. Riverside County and City of Moreno Valley will not be held responsible for any claims, losses or damages resulting from the use of this map. This map is not to be recycled or resold.

-  Landscaped Median
-  Landscaped Parkway
-  Zone E-16 Parcels

Map Produced by Moreno Valley
Geographic Information System
File: C:\ArcMap\Special Districts
E16_8.5x11.mxd
November 29, 2007



**Moreno Valley Community Services District
 Extensive Landscaping & Irrigation**

Zone D-SG1 • Full Service

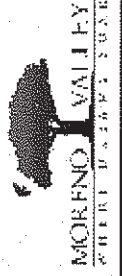
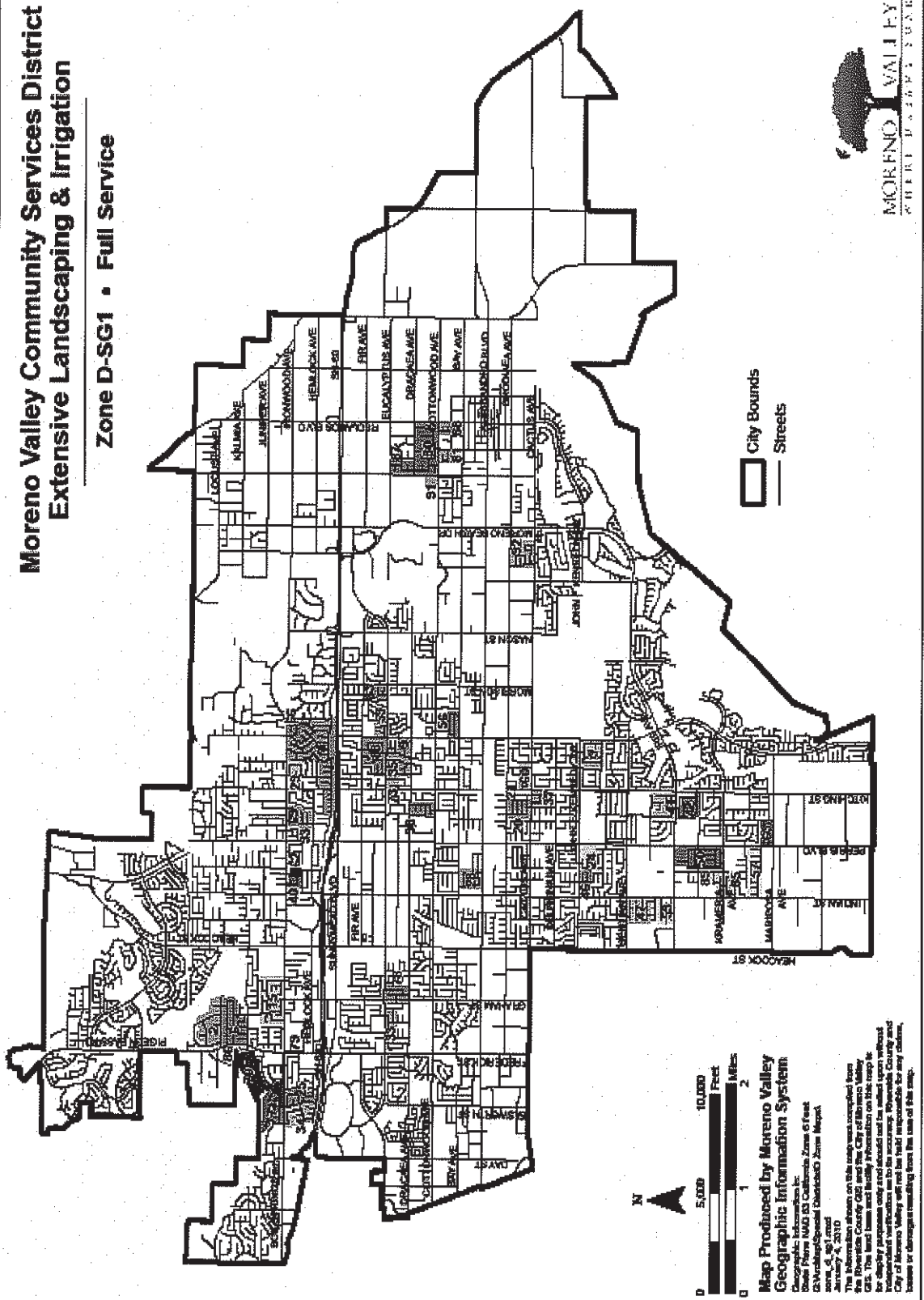

**Moreno Valley Community Services District
 Extensive Landscaping & Irrigation
 Zone D-SG2 - South • Reduced Service**

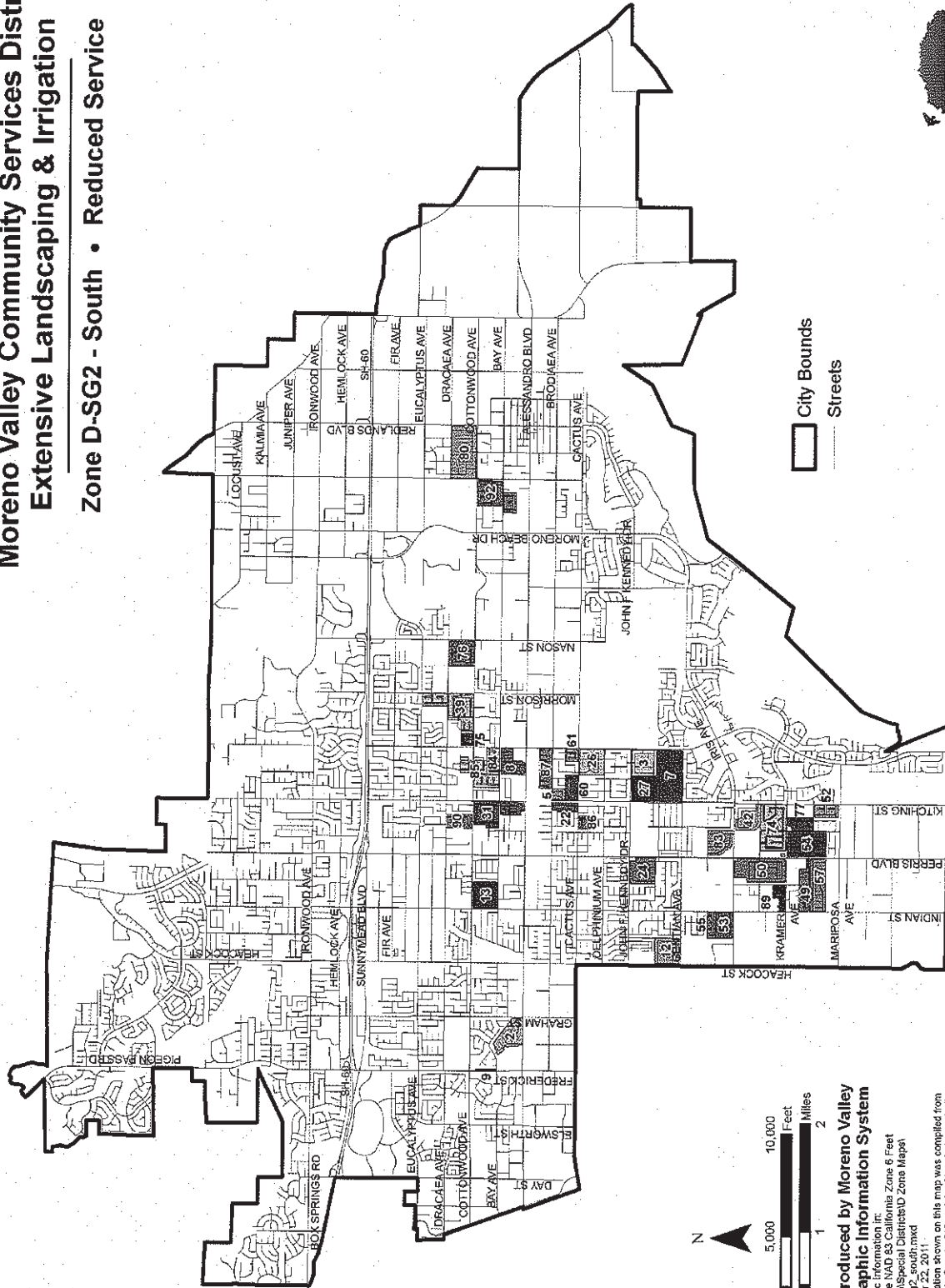

0 5,000 10,000 Feet
 0 1 2 Miles

**Map Produced by Moreno Valley
 Geographic Information System**
 Geographic Information System
 State Plane NAD 83 California Zone 8 Feet
 G:\ArchMap\Special District\ID Zone Map\id
 zone_d_s92_south.mxd
 September 22, 2011

The information shown on this map was compiled from the Riverside County GIS and the City of Moreno Valley GIS. The base and metadata information on this map is derived from the Riverside County GIS. The City of Moreno Valley has not conducted independent verification as to its accuracy. Riverside County and the City of Moreno Valley will not be held responsible for any claims, losses or damages resulting from the use of this map.



Moreno Valley Community Services District Extensive Landscaping & Irrigation

Zone M • Median - Monument - Parkway

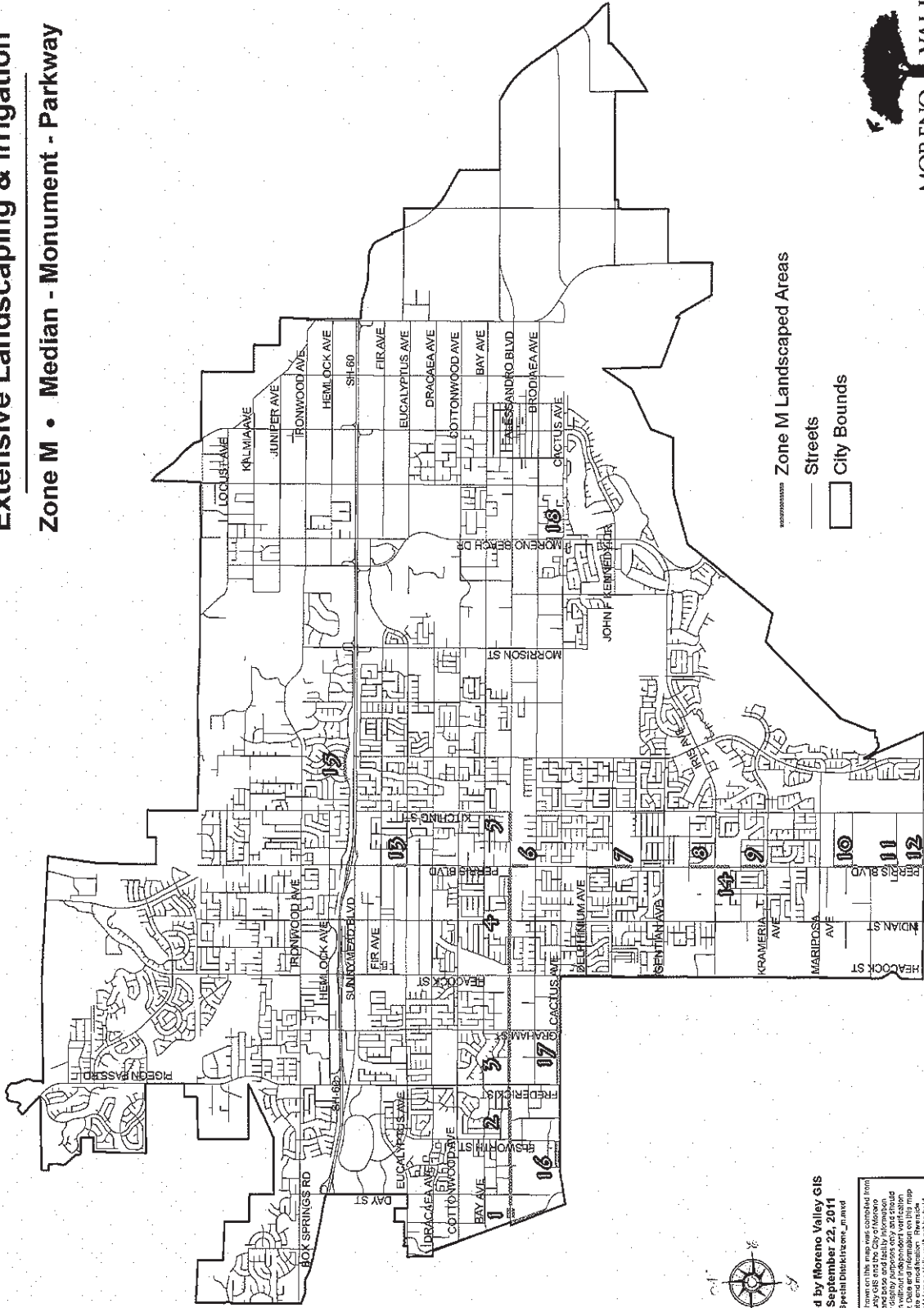

Map Created by Moreno Valley GIS
 Print Date: September 22, 2011
 File: C:\ArcMap\Spatial_Districts\zone_m.aprx

The information shown on this map was compiled from
 Moreno Valley GIS. The land base and facility information
 on this map is for display purposes only and should
 not be used for any other purpose. The information on this map
 is to its accuracy. Data or information on this map
 is the property of Moreno Valley and will not be held
 responsible for any errors, losses or damages
 that may be incurred or arise. This map is
 not to be reproduced or copied.

Moreno Valley Community Services District Extensive Landscaping & Irrigation

Zone M • Medians - Monuments - Parkways

Alessandro Boulevard Medians & Monuments

1. Old Hwy 215 Monuments
 - 17,885 square feet (includes 5,477 sq.ft. turf)
 - 8 trees
 - 4 remote control valves - 1 controller
2. Old Hwy 215 to Frederick Street
 - 60,423 square feet (includes 21,325 sq.ft. turf)
 - 75 trees
 - 32 remote control valves - 2 controllers
3. Frederick Street to Heacock Street
 - 68,445 square feet (includes 34,585 sq.ft. turf)
 - 64 trees
 - 22 remote control valves - 2 controllers
4. Heacock Street to Perris Boulevard
 - 15,009 square feet
 - 4 trees
 - 4 remote control valves - 2 controllers
5. Flaming Arrow Dr to Kitching St
 - 17,470 square feet
 - 21 trees
 - 16 valves - 1 controller

Perris Boulevard Medians

6. South of Alessandro Boulevard
 - 471 square feet
 - 1 tree
 - 2 remote control valves - 1 controller
7. South of John F. Kennedy Drive
 - 1,136 square feet
 - 3 trees
 - 3 remote control valves - 1 controller
8. North of Iris Ave
 - 2,200 square feet
 - 7 trees
 - 4 valves - 1 controller
9. North of Krameria Avenue
 - 3,324 square feet
 - 5 trees
 - 3 valves - 1 controller
10. At San Michele Road
 - 5,335 square feet
 - 10 trees
 - 6 valves - 1 controller
11. Perris Blvd (North of Globe St)
 - 4,110 square feet
 - 8 trees
 - 1 controller
12. Perris Blvd (South of Globe St)
 - 4,950 square feet
 - 12 trees
 - 7 valves - 1 controller

Elder Avenue Retention Basin Parkway

13. South Side of Elder Avenue from Grenville Avenue to Brewster Drive
 - 471 square feet
 - 1 tree
 - 2 remote control valves - 1 controller

Cactus Avenue Medians

14. Cactus Ave. west of Elsworth
 - 2500 square feet
 - 5 trees
 - 4 valves - 1 controller

Print Date: October 4, 2007
File: d:\mval\ppl\ppl\2007\zone_m_ppl.rvt

19. TREE TRIMMING/REMOVAL LIST

Zone	Street Section	Tree Species	Work to be Performed Trim or Removal	No of Trees to be Trimmed	No of Trees to be Removed
E-1 TownGate	N/S Towngate Blvd. from Frederick to Eucalyptus	London Plane	Trim	49	0
	S/S Towngate Blvd. from Frederick to Eucalyptus	London Plane	Trim	52	0
	E/S Day from Eucalyptus to Gateway	Liquid Ambar	Trim	5	0
	E/S Day from Gateway to Campus	Liquid Ambar	Trim	4	0
	E/S Day from Gateway to Campus	Liquid Ambar	Remove	1	1
	E/S Day from Campus to Freeway	Liquid Ambar	Trim	14	0
	Total (E-1)			124	1
E-1 A TownGate	S/S Dracea from Elsworth to Arbor Park	Eucalyptus	Trim	3	0
	N/S Dracea from Elsworth to Arbor Park	Eucalyptus	Trim	6	0
	N/S Dracea from Arbor Park to Day	Eucalyptus	Trim	9	0
	S/S Dracea from Arbor Park to Day	Eucalyptus	Trim	7	0
	Total (E-1A)			25	0
E-2 Hidden Springs	Hidden Springs from Pigeon pass to Mountain View	Sycamore	Trim	8	0
	Hidden Springs from Pigeon pass to Mountain View	Eucalyptus	Trim	1	0
	Hidden Springs from Mountain View to Country Gate	Sycamore	Trim	14	0
	Hidden Springs from Mountain View to Country Gate	Alder	Trim	3	0
	Hidden Springs from Mountain View to Country Gate	Alder	Remove	0	1
	Hidden Springs from Country Gate to Mountain View	Sycamore	Trim	10	0
	Hidden Springs from Country Gate to Mountain View	Alder	Trim	9	0
	Hidden Springs from Country Gate to Mountain View	Alder	Remove	0	1
	Hidden Springs from Mountain View to Shadow Ridge	Tipuana	Trim	1	0
	Hidden Springs from Mountain View to Shadow Ridge	Sycamore	Trim	6	0
	Hidden Springs from Mountain View to Shadow Ridge	Alder	Trim	7	0
	Hidden Springs from Mountain View to Shadow Ridge	Tipuana	Trim	2	0
	Hidden Springs from Shadow Ridge to Mesa Springs	Sycamore	Trim	5	0
	Hidden Springs from Shadow Ridge to Mesa Springs	Tipuana	Trim	3	0
	Hidden Springs from Shadow Ridge to Mesa Springs	Tipuana	Remove	0	3
	Hidden Springs from Mesa Springs to Pebble Brook	Sycamore	Trim	7	0
	Hidden Springs from Mesa Springs to Pebble Brook	Alder	Trim	5	0
	Hidden Springs from Mesa Springs to Pebble Brook	Alder	Remove	0	4
	Hidden Springs from Mesa Springs to Pebble Brook	Pepper	Trim	17	0
	Hidden Springs from Mesa Springs to Pebble Brook	Tipuana	Remove	0	1
	Hidden Springs from Country Crest to Del Cresta	Alder	Trim	13	0
	Hidden Springs from Country Crest to Del Cresta	Alder	Remove	0	6
	Hidden Springs from Country Crest to Del Cresta	Eucalyptus	Trim	1	0

Zone	Street Section	Tree Species	Work to be Performed Trim or Removal	No of Trees to be Trimmed	No of Trees to be Removed	
E-2 Hidden Springs (Cont.)	Hidden Springs from Del Cresta to Box Springs Park	London Plane	Trim	19	0	
	Hidden Springs from Del Cresta to Box Springs Park	Alder	Trim	19	0	
	Hidden Springs from Del Cresta to Box Springs Park	Alder	Remove	0	2	
	Main Paseo entrance on Hidden Springs	Pepper	Trim	1	0	
	Main Paseo entrance on Hidden Springs	Eucalyptus	Trim	1	0	
	N/W corner of Del Cresta and Hidden Springs	Pepper	Trim	7	0	
	S/W corner of Del Cresta and Hidden Springs	Pepper	Trim	10	0	
	North side of Del Cresta and Cartegena dr.	Pepper	Trim	9	0	
	S/W corner of Escorial and Del Cresta	Pepper	Trim	4	0	
	S/E corner of Shadow Ridge and Mesa Springs	Pepper	Trim	3	0	
	S/W corner of Moralla and Belcanto	Pepper	Trim	2	0	
	Paseo main entrance of Hidden Springs	Pepper	Trim	1	0	
	West side of Altabrisa	Pepper	Trim	1	0	
	Total (E-2)				188	18
	E-3 MV Ranch - West	In median North of Iris on Lasselle	London Plane	Trim	2	0
East side of Lasselle North of Iris to Gentian		London Plane	Trim/Removal	23	3	
East side of Lasselle North from Gentian to Casa Encantador		London Plane	Trim/Removal	8	2	
East side of Lasselle North of Casa Encantador to the School		London Plane	Trim	7	0	
West side of Lasselle South from Gentian to Iris		London Plane	Trim	13	0	
West side of Lasselle South from Iris to Calle Agua		London Plane	Trim/Removal	19	9	
West side of Lasselle South from Calle Agua to Krameria		London Plane	Trim	15	0	
North side of Krameria West from Lasselle to Calle Serena		Acacia Baileyana	Removal	0	3	
North side of Krameria West from Lasselle to Calle Serena		London Plane	Removal	0	5	
West side of Lasselle South from Krameria to Yanez Trail		London Plane	Trim	12	0	
West side of Lasselle South from Yanez Trail to Via Xavier		London Plane	Trim/Removal	6	1	
West side of Lasselle South from Via Xavier to Arroyo Park		London Plane	Trim	13	0	
West side of Lasselle South from Arroyo Park to Avenida Plata		London Plane	Trim	4	0	
West side of Lasselle from Avenida Plata to Avenida Classica		London Plane	Trim	12	0	
West side of Lasselle South from Avenida Classica to Camino Del Rey		London Plane	Trim	26	0	
East side of Lasselle North from Kentucky Derby to Cremello		London Plane	Trim	23	0	
East side of Lasselle North from Cremello to Rojo Tierra		London Plane	Trim	5	0	
East side of Lasselle North from Rojo Tierra to Via Xavier		London Plane	Trim	26	0	
East side of Lasselle North from Via Xavier to Krameria		London Plane	Trim	13	0	
In the medians South from Calle Agua to Kentucky Derby		Palms	Trim	92	0	
SEC of Gentian & Lasselle		Peppers	Trim	8	0	
SEC of Gentian & Lasselle		Peppers	Trim	1	0	
SWC of Gentian & Lasselle		Peppers	Trim	1	0	
SWC of Iris & Lasselle	Palms	Trim	8	0		

Zone	Street Section	Tree Species	Work to be Performed Trim or Removal	No of Trees to be Trimmed	No of Trees to be Removed	
E-3 MV Ranch - West (Cont.)	SWC of Iris & Lasselle	Peppers	Trim	1	0	
	SEC of Iris & Lasselle	Palms	Trim	8	0	
	SEC of Iris & Lasselle	Peppers	Trim	1	0	
	NEC of Iris & Lasselle	Palms	Trim	10	0	
	NWC of Iris & Lasselle	Palms	Trim	3	0	
	NEC of Krameria & Kitching	Palms	Trim	4	0	
	NEC of Krameria & Kitching	Peppers	Trim	1	0	
	SEC of Krameria & Kitching	Palms	Trim	6	0	
	SEC of Krameria & Kitching	Peppers	Trim	1	0	
	S/S of Krameria W/of Camino Juanito St.	Oak	Trim	1	0	
	SEC of Iris & Kitching	Palms	Trim	8	0	
	SEC of Iris & Kitching	Peppers	Trim	1	0	
	NEC of Iris & Kitching	Palms	Trim	8	0	
	NEC of Iris & Kitching	Peppers	Trim	1	0	
	Both corners on the North Side of Iris & Ponderosa	Peppers	Trim	2	0	
	Total (E-3)				393	23
	E-4 MV Ranch - East	In median North of JFK to Cactus	London Plane	Trim	35	0
In median North of JFK to Cactus		Oak	Trim	1	0	
East side parkway North of JFK to Artisan		Liquid Ambar	Trim	10	0	
East side parkway North of Artisan to Cactus		London Plane	Trim	25	0	
North from Iris to JFK		Liquid Ambar	Trim	22	0	
East from Legendary to Via Entrada		London Plane	Trim	29	0	
East from Via Entrada to Moreno Beach		Liquid Ambar	Trim	10	0	
East from Via Entrada to Moreno Beach		Oak	Trim	3	0	
On the West side of Moreno Beach from JFK		Liquid Ambar	Trim	6	0	
On the West side of Moreno Beach from JFK		Liquid Ambar	Removal	0	1	
East side of Moreno Beach from Championship to JFK		Liquid Ambar	Trim	11	0	
East side of Moreno Beach from Championship to JFK		Oak	Trim	1	0	
East side of Moreno Beach from Championship to JFK		London Plane	Trim	3	0	
South side of Iris from Oliver to Via Del Lago		Liquid Ambar	Trim	9	0	
South side of Iris from Oliver to Via Del Lago		Liquid Ambar	Trim	4	0	
In the median on Via Del Lago South from Iris/Moreno Beach		Palos Verde	Trim	30	0	
South West & South East corner of JFK/Bay Hill		Pepper	Trim	2	0	
South West & South East corner of JFK/Sevilla		Pepper	Trim	2	0	
West side of Hammet on Iris		Pepper	Trim	1	0	
Various To Be Determined in the Field (Due to raised sidewalks)		Pine & Sycamore	Removals	0	80	
Total (E-4)				204	81	

Zone	Street Section	Tree Species	Work to be Performed Trim or Removal	No of Trees to be Trimmed	No of Trees to be Removed
E-7 Centerpointe	Northwest corner Frederick / Alessandro Northwest corner Frederick / Alessandro Northeast corner Frederick/ Alessandro Northeast corner Frederick/ Alessandro Southwest corner Frederick/Alessandro Southwest corner Frederick/Alessandro Southeast corner Frederick/Alessandro Southeast corner Frederick/Alessandro Median on Cactus east of Veterans Way Median on Cactus east of Veterans Way and Elsworth Cactus Parkway between Veterans Way and Elsworth Elsworth between Cactus/Goldencrest Elsworth north of Goldencrest	Palm	Trim	3	0
		Pepper	Trim	4	0
		Palm	Trim	4	0
		Pepper	Trim	4	0
		Palm	Trim	4	0
		Pepper	Trim	4	0
		Palm	Trim	4	0
		Pepper	Trim	4	0
		London Plane	Trim	4	0
		London Plane	Trim	10	0
		London Plane	Trim	10	0
		Camphor	Trim	7	0
		Camphor	Trim	13	0
		Total (E-7)			
E-8 Promontory Park	Oliver Street - East side from Cactus St. to John F. Kennedy Dr.	Chitalpa	Trim	36	0
		Total (E-8)		36	0
E-14 Mahogany Fields	Cottonwood Ave. S/s on the E and W side of Jade Way Alessandro Blvd., N/s between Darwin Dr. to the end of the tract's parkway Alessandro Blvd., N/s between Darwin Dr. to the end of the tract's parkway	Palo Verde	Trim	6	0
		Hollywood Juniper	Trim	8	0
		Pine	Trim	25	0
		Total (E-14)		39	0
E-15 Celebration	Oliver Street, W/s, Between Cactus Ave. to the water basin Nason Street, E/s, Between Cactus Ave. and Delphinium Ave.	Chitalpa	Trim	42	0
		Palo Verde	Trim	8	0
Total (E-15)				50	0
E-16 Shadow Mountain	North side Sunnymead Parkway from Via Del Norte to Pigeon Pass North side Sunnymead Parkway from Via Del Norte to Pigeon Pass Sunnymead Pkway - Camphors located within the median East side Pigeon Pass from Sunnymead Parkway to Presido Hills East side Pigeon Pass from Sunnymead Parkway to Presido Hills East side Pigeon Pass from Presido Hills to Lawless North Side Presido Hills from Pigeon Pass to Via Montara	Pepper	Trim	4	0
		Sycamore	Trim	21	0
		Camphor	Trim	8	0
		Liquid Ambar	Trim	2	0
		Liquid Ambar	Removal	0	3
		Liquid Ambar	Removal	0	1
		Liquid Ambar	Removal	0	1
Total (E-16)				35	5

Zone	Street Section	Tree Species	Work to be Performed Trim or Removal	No of Trees to be Trimmed	No of Trees to be Removed	
DSG-1 Tracts	TR 31129	London Plane	Trim	3	0	
	TR 22371	Liquid Ambar	Removal	0	1	
	TR 22371	Plum	Removal	0	3	
	TR 19541	Plum	Removal	0	6	
	TR 19541	Liquid Ambar	Removal	0	2	
	TR 20941	Palm	Trim	22	0	
	TR 19474	Palm	Trim	8	0	
	TR 18283	London Plane	Trim/Removal	13	2	
	TR 19862	London Plane	Trim	6	0	
	TR 32715	London Plane	Trim	8	0	
	TR16769	Eucalyptus	Trim	3	0	
	TR 21597	London Plane	Trim	33	0	
	TR 19141	Liquid Ambar	Removal	0	3	
	TR 20120	Liquid Ambar	Removal	0	1	
	Total (D - DSG-1)				96	18
	DSG-2 South Tracts	TR 16770	Liquid Ambar	Removal	0	1
		TR 19937	Oak	Removal	0	1
TR 19852		Oak	Trim	3	0	
TR 19852		Oak	Trim	10	0	
TR 19852		Oak	Trim	5	0	
TR 30027		Palo Verde	Trim	15	0	
TR 30027		Olive	Trim	9	0	
TR 30027		Palo Verde	Trim	8	0	
TR 19518		Pine	Trim	9	0	
TR 19518		Pine	Removal	0	1	
TR 19685		Palm	Trim	3	0	
TR 19685		Palm	Trim	7	0	
TR 19685		Palm	Trim	3	0	
TR 19685		Palm	Trim	3	0	
TR 19685		Palm	Trim	4	0	
TR 20715		Palm	Trim	3	0	
TR 20715		Oak	Trim	2	0	
TR 20715	Oak	Trim	3	0		
TR 20715	Oak	Trim	3	0		

Zone	Street Section	Tree Species	Work to be Performed Trim or Removal	No of Trees to be Trimmed	No of Trees to be Removed	
DSG-2 South Tracts (Continued)	Indian St., W/s between Gentian Ave. and Creekstone Dr.	London Plane	Trim	6	0	
	TR 20552	London Plane	Trim	23	0	
	TR 20552	London Plane	Trim	5	0	
	TR 20404	London Plane	Trim	48	0	
	TR 20404	Pine	Trim	18	0	
	Total (D - DSG-2 North)				198	3
DSG-2 North Tracts	Mathews	Pine	Trim	32	0	
	TR 17033	Pepper	Trim	10	0	
	TR 24721	Eucalyptus	Trim	34	0	
	TR 17334	Palm	Trim	20	0	
	TR 19208	Palm	Trim	8	0	
	TR 28882/18784	Liquid Ambar	Removal	0	10	
	TR 18512/21322	Liquid Ambar	Removal	0	6	
	TR 18930	Pine & Liquid Ambar	Trim	32	0	
	TR 17176	Pepper	Trim	11	0	
	TR 22276/22277	Liquid Ambar	Trim	5	0	
	TR 21333	Eucalyptus & Pine	Trim	32	0	
	Total (D - DSG-2 South)				184	16
	Zone M - Medians	San Michelle Rd.			1	0
Alessandro Blvd., W/s between Frederick St. and City Limit				14	0	
Veterans Way				0	1	
Total (M - Medians)				15	1	
Grand Total				1,662	166	

EXHIBIT B: District Responsibilities

R.F.P. NO. 2011 TREE TRIM/REMOVAL
PROJECT NO. 2011 TREE TRIM/REMOVAL

PARKWAY AND MEDIAN
TREE TRIMMING AND REMOVAL

1. CONTRACT SUPERVISION

- A. The Contract shall be administered on behalf of the District by the Director of Public Works of the City of Moreno Valley, or his/her delegated representative(s), hereinafter designated as "Director."
- B. The Director will decide all questions which may arise as to the manner of performance and completion per schedule, acceptable fulfillment of the Contract by the Contractor, interpretation of the Specifications, and compensation to include completion of work by alternate sources.

2. IRRIGATION SYSTEMS

The District shall manage the operation of all automatically controlled irrigation systems, including but not limited to irrigation controller programming and scheduling adjacent to the tree trimming sites. .

3. UTILITIES

It shall be the District's duty to provide the utilities necessary for irrigation (e.g., water, electricity and communications), and to maintain their appurtenances (e.g., water and electrical meters and backflow devices). The District will pay the water, electricity, and communications costs used in the sites covered by this Contract. The Contractor shall report any interruption of these services for whatever reason immediately upon Contractor's observation of same to the Director.

4. CONTRACTED LANDSCAPE MAINTENANCE SCHEDULES

The District shall provide the Contractor with a schedule of routine landscape maintenance operations at the site(s) in question. The Contractor shall provide a Tree Trimming Schedule as necessary to accommodate the other landscape maintenance activities. The Contractor's Tree Trimming Schedule must be submitted to the Director for approval within ten (10) working days after the effective date of the Contract.

EXHIBIT C: Payment Terms
R.F.P. NO. 2011 TREE TRIM/REMOVAL
PROJECT NO. 2011 TREE TRIM/REMOVAL

PARKWAY AND MEDIAN
TREE TRIMMING AND REMOVAL

1. CONTRACTOR'S COMPENSATION

A. The Contractor will be paid monthly based on the number of trees trimmed/removed per site, for the work performed satisfactorily under this Contract. By the tenth of each month the Contractor will electronically submit to the Director detailed reports for the: 1) maintenance performed, 2) Greenwaste, 3) complaints received, 4) hazards noted, 5) chemicals used in the prior month 5) a detailed invoice for services in accordance with the Contract price for the work performed, which shall become the basis for payment. No payment(s) shall be made until the reports, listed herein, have been submitted and approved. The Contractor will submit all original invoices to Accounts Payable staff at AccountsPayable@moval.org.

Accounts Payable questions can be directed to (951) 413-3073.

Copies of invoices and reports will be submitted to the Special Districts Division of the Public Works Department at specialdistricts@moval.org. Calls may also be directed to the Special Districts Division at (951) 413-3480.

B. The Contractor will obtain, and keep current during the term of this Contract, the required City of Moreno Valley business license. Proof of a current City of Moreno Valley business license will be required prior to any payments by the City. Any invoice not paid because the proof of a current City of Moreno Valley business license has not been provided will not incur any fees, late charges, or other penalties. Complete instructions for obtaining a City of Moreno Valley business license are located at http://www.moval.org/do_biz/biz-license.shtml.

C. Except where additional compensation is specifically provided for in this Contract, the District will pay the Contractor for all trees trimmed/removed (this cost includes labor, material, supplies, equipment, etc. as necessary to perform such service) under this Contract and shall be based upon the total number of trees trimmed and/or removed per area per month, one (1) month in arrears, on the last day of the month. The total contract amount for the twelve (12) month contract term shall not exceed Ninety-three thousand, two hundred and twenty dollars and zero/100 (\$93,220.00), except as provided for in Section 2 below.

D. The Contractor agrees that City payments will be received via Automated Clearing House (ACH) Direct Deposit and that the required ACH Authorization form will be completed prior to any payments by the City. Any invoice not paid because the completed ACH Authorization Form has not been provided will not incur any fees, late charges, or other penalties. The ACH Authorization Form is located at:

- E. The minimum information required on all invoices includes:
1. Vendor Name, Mailing Address and Phone Number
 2. Invoice Date
 3. Vendor Invoice Number
 4. City – provided Reference Number (Project No. and Title)
 5. Detailed work hours by class title (e.g. Manager, Technician, or Specialist), services performed, and rates, explicit portion of a contract amount or detailed billing information is sufficient to justify the invoice amount: single or lump sum amounts without detail are not acceptable.
- F. The City shall pay the Contractor for all invoiced, authorized professional services within thirty (30) days of receipt of the invoice for the same.

2. **ADDITIONAL WORK**

- A. During the term of this Contract the District may, at its discretion, authorize the Contractor to perform certain Additional Work as included in Section 2., paragraph C. herein this Exhibit, ("Additional Work"), in addition to the work set forth in Exhibit A, Contractor's Scope of Work.

If the District determines it to be in the District's best interest, said Additional work may include: Acts of God (e.g., earthquake damage, storm damage), vandalism, theft, and acts or omissions by third parties.

Compensation for all such Additional Work shall be calculated either: at the prices set forth by the Contractor in Exhibit E, Schedule II, Section II, Additional Work Price List, or at a price based on the Contractor's written estimate (lump sum, time and materials, or cost plus basis), as determined by the Director. Except as set forth in Section 2, paragraph B. below, the Contractor shall not perform any such Additional Work without first obtaining express written authorization from the District.

- B. Notwithstanding the above requirement for prior written authorization, when a condition exists wherein there is imminent danger of injury to the public or damage to property, the District may verbally authorize the work to be performed upon receiving a verbal estimate from the Contractor. Within twenty-four (24) hours after receiving a verbal authorization, the Contractor must submit a written estimate to the District for written approval. Whenever immediate action is required to prevent impending injury, death, or property damage to the facilities being maintained, the District may, after reasonable attempt to notify the Contractor, cause such action to be taken by the District or City's work force.

- C. The Contractor shall maintain as Additional Work, at a unit price comparable to tree trimming and removals described herein, additional trims and removals that the District may add to this Contract. .
- D. Except as specifically approved by subsequent action of the District Board of Directors, the Director may not authorize Additional Work pursuant to paragraphs A., B., and C. above in excess of the cumulative total of \$0.00 for each contract year during the term of this Contract.

3. PAYMENT DEDUCTIONS

The District may deduct payment to such extent as may be necessary to protect the District from loss due to:

- A. Work required in the General or Special Provisions which is: not performed, or; not performed to the standards set forth therein, or; not performed at or within the time(s) specified therein, or; is incomplete;
- B. Claims filed or reasonable evidence indicating probable filing of claims by laborers, materialmen, subcontractors, or third parties.

4. NON-PERFORMANCE PENALTIES

The Contractor may become liable for payment of non-performance penalties for failure to: provide adequate communications; provide adequate work area safety; complete operations in a timely manner as set forth in the General Provisions; submit notifications or reports required by the Contract, or General or Special Provisions at the intervals and/or frequencies set forth therein, or; perform work as required by the General or Special Provisions at the intervals and/or frequencies as set forth therein, or as set forth in Contractor's approved work schedule, or as directed by the District. For each of the categories set forth hereinabove, the penal sum of \$100.00 (one hundred dollars) per working day will be assessed for each working day the deficiencies remain uncorrected.

If non-performance penalties are to be assessed, the Contractor will be notified immediately in writing by electronic mail, facsimile transmission, or written and mailed correspondence or by telephone.

The Contractor will not be assessed non-performance penalties for delays caused by the District, or by the owner of a utility to provide for the removal or relocation of utility facilities.

EXHIBIT D: Term of Contract
R.F.P. NO. 2011 TREE TRIM/REMOVAL
PROJECT NO. 2011 TREE TRIM/REMOVAL

PARKWAY AND MEDIAN
TREE TRIMMING AND REMOVAL

1. TERM OF CONTRACT

- A. Following approval by both parties, the Contract will commence on November 1, 2011, and shall terminate on June 30, 2012.
- B. At the expiration of its term, the Contract may be extended for up to four (4) additional twelve (12) month periods with the concurrence of both parties. Written notice of the District's intent to invoke this subsection of the Contract (Exhibit D., Section 1., paragraph B.) shall be given to the Contractor at least thirty (30) days prior to the expiration of the initial term of the Contract or any extension thereof.
- C. In considering the option to extend the Contract, as set forth in paragraph B. above, the District shall determine the following:

That the Contractor's performance during the preceding twelve months has been satisfactory, and;

That any request for increase of Contractor's compensation is based on an annual inflation adjustment based on the percentage increase calculated for the previous calendar year in the Los Angeles-Riverside-Orange County Regional Consumer Price Index for All Urban Consumers, as published by the Department of Labor's Bureau of Labor Statistics.

- D. It should be noted that multiyear contracts may be continued each fiscal year only after funding appropriations and program approvals have been granted by the City Council of the City of Moreno Valley and the City Council acting in the capacity as President and Members of the Board of Directors of the Moreno Valley Community Services District. (CSD) In the event that the City Council and/or the City Council acting in the capacity as President and Members of the Board of Directors for the CSD does not grant necessary funding appropriations and/or program approval, the affected multiyear contract becomes null and void, effective July 1st of the fiscal year for which such approvals have been denied.

EXHIBIT E: PROPOSAL SUBMITTAL DOCUMENTS

R.F.P. NO. 2011 TREE TRIM/REMOVAL
PROJECT NO. 2011 TREE TRIM/REMOVAL

PARKWAY AND MEDIAN
TREE TRIMMING AND REMOVAL

SCHEDULE I

R.F.P. NO. 2011 TREE TRIM/REMOVAL
PROJECT NO. 2011 TREE TRIM/REMOVAL

PARKWAY AND MEDIAN
TREE TRIMMING AND REMOVAL

ATTACH ADDITIONAL SHEETS AS NECESSARY FOR COMPLETE RESPONSES

I. VENDOR INFORMATION

A. COMPANY NAME: West Coast Arborists, Inc.

TYPE

- Sole proprietor _____
- Partnership _____
- Corporation x _____

B. COMPANY ADDRESS/PHONE NUMBER

MAIN OFFICE ADDRESS:

2200 E. Via Burton St.

Anaheim, CA 92806

MAIN OFFICE PHONE NUMBER: 714-991-1900

SATELLITE OFFICE ADDRESS (if applicable):

Regional Office

21718 Walnut Ave.

Grand Terrace, CA 92313

SATELLITE OFFICE PHONE NUMBER 909-783-6544

C. CONTRACTOR'S LICENSING INFORMATION:

LICENSE NUMBER/CLASSIFICATION/NAME STYLE: 366764 C27/C61/D49

NUMBER OF YEARS OPERATING UNDER ABOVE LICENSE/NAME STYLE: 39

LICENSE EXPIRATION DATE: 12/31/2012

CURRENT LICENSE STATUS: Good Standing

PRIOR ACTIONS AGAINST THIS LICENSE? Yes / No

IF YES, LIST CITATION TYPE AND HOW RESOLVED: N/A

D. COMPANY'S FEDERAL IDENTIFICATION NO.: 95-3250682

E. NAME AND TITLE OF COMPANY OFFICERS:

Patrick Mahoney, President

Richard Mahoney, Secretary

Rose Epperson, Treasurer

F. NUMBER OF YEARS COMPANY HAS PERFORMED TREE TRIMMING AND REMOVAL SERVICES: 40+

G. NUMBER OF YEARS COMPANY HAS PERFORMED TREE TRIMMING AND REMOVAL SERVICES FOR PUBLIC AGENCIES: 39

H. CURRENT TREE TRIMMING AND/OR TREE REMOVAL MAINTENANCE SERVICE OPERATIONS

THE DISTRICT RECOGNIZES THAT THE INFORMATION PROVIDED TO THIS QUESTION (QUESTION H.) IS PROPRIETARY IN NATURE, AND THEREFORE, THE DISTRICT WILL KEEP THIS INFORMATION CONFIDENTIAL TO THE EXTENT PERMITTED BY LAW.

TOTAL TREE TRIMMING/REMOVAL CONTRACTS: 200+

PERCENTAGE OF TOTAL CONTRACTS WITH PUBLIC AGENCIES: 95%

TOTAL DOLLAR VALUE OF TREE TRIMMING/REMOVAL CONTRACTS: \$48 million

1. NUMBER OF EMPLOYEES COMMITTED TO TREE TRIMMING/REMOVAL OPERATIONS

SUPERVISORS: <u>20</u>	AVERAGE WAGE SCALE: \$ <u>60,000</u> /YR. *
TECHNICIANS: <u>10</u>	AVERAGE WAGE SCALE: \$ <u>35.00</u> /Hr.*
FOREMEN: <u>118</u>	AVERAGE WAGE SCALE: \$ <u>30.00</u> /Hr.*
LABORERS: <u>344</u>	AVERAGE WAGE SCALE: \$ <u>20.00</u> /Hr.*

*Use fully burdened rate (e.g., taxes, insurance, benefits, OH &P) - This is a prevailing wage project.

2. TYPE & NUMBER OF VEHICLES & POWER EQUIPMENT COMMITTED TO TREE TRIMMING/REMOVAL OPERATIONS:

A. MOTOR VEHICLES Please refer to attachment "III" Section B.

• TYPE: _____	NUMBER: _____
• TYPE: _____	NUMBER: _____
• TYPE: _____	NUMBER: _____
• TYPE: _____	NUMBER: _____

B. POWER EQUIPMENT

Please refer to attachment "III" Section B.

- TYPE: _____ NUMBER: _____
- TYPE: _____ NUMBER: _____
- TYPE: _____ NUMBER: _____
- TYPE: _____ NUMBER: _____

II. REFERENCES

ATTACH RESPONSES ON ADDITIONAL SHEETS - ONE SHEET PER REFERENCE

1. LIST A MINIMUM OF THREE (3) REFERENCES FOR PUBLIC AGENCY LANDSCAPE MAINTENANCE CONTRACTS THAT ARE EITHER CURRENT AND/OR HAVE BEEN SUCCESSFULLY COMPLETED WITHIN THE LAST TWO (2) YEARS.
2. REFERENCE RESPONSES MUST INCLUDE:
 - A. NAME AND ADDRESS OF AGENCY;
 - B. NAME AND TELEPHONE NUMBER OF AGENCY;
 - C. PERSON RESPONSIBLE FOR ADMINISTERING CONTRACT;
 - D. CONTRACT NAME(S) / NUMBER(S);
 - E. ANNUAL CONTRACT AMOUNT(S);
 - F. NUMBER OF TREES TRIMMED/REMOVED PER CONTRACTS(S);
 - G. LOCATION(S) OF CONTRACT AREAS – WE MAY VISIT SITE(S);
 - H. LENGTH OF CONTRACT(S).
3. THE FOLLOWING REFERENCE QUESTIONS WILL BE ASKED OF EACH AGENCY REFERENCED:
 - A. How many (number) of contracts and years under contract?
 - B. What are/were the Scope of the contract(s), No. of trees serviced. Locations(s)
 - C. What are/were the Contract amount(s)?
 - D. Do/did they have adequate (quantity/quality) staffing?
 - E. How are/were the Training/Technical skills (e.g., Use and Operation of Equipment/Safety)?
 - F. Does staff have the ability to comprehend/speak English?
 - G. How are/were the appearance, uniforms, and use of safety equipment?
 - H. Do/did they have availability of additional personnel for extra work/special projects?
 - I. Is/was the equipment used in good working order?
 - J. Do/did they have an effective in-company communications system?
 - K. How is/was the knowledge of project/contract standards?
 - L. Do/did they have the ability to respond to complaints/requests in a timely fashion?
 - M. Are/were they willing to resolve questions, disputes, and deficiencies short of “formal” sanctions (e.g., monetary penalties, contract deductions, liquidated

- damages, claims against bonds)?
- N. How accurate & timely is/was billing/invoicing?
 - O. Have Contract(s) been successfully completed to term?
 - P. Would you accept future proposals/bids from this company?

III. PROPOSED FACILITIES, EQUIPMENT, & STAFFING

- A. **Facilities** – List the facility(ies) location and/or address where work crews and equipment will be dispatched. Use additional sheets as necessary to provide a full and comprehensive response.

The Project Manager, Supervisor, and Customer Service Representative will dispatch crews and equipment from the Regional Office located in Grand Terrace. Other various day to day tasks as related to billing and contract management will be managed from the Corporate office in Anaheim. Further detail and organization is attached.

- B. List the equipment, motor vehicles, and tools, in the areas below that will be furnished to execute work tasks specified in the Contract, General Provisions, and Special Provisions. Indicate with (S) any listed equipment to be shared with another contract/ project. Use additional sheets as necessary to provide a full and comprehensive response.

1. **Equipment:**

A complete list of designated equipment is attached.

2. **Motor Vehicles:**

A complete list of designated motor vehicles that will be available for this project is attached.

3. **Tree Trimming /Pruning/Removal Equipment:**
(list both powered and hand equipment/tools)

Chain saws, pole saws, hand saw, pole pruner, ladder, chipper, grinder, blower, shovels, broom, rakes, chipper feeder

- C. **Staff:** - List the employees, both labor and supervision, to be routinely assigned to execute work tasks specified in the Contract, General Provisions, and Special Provisions. Be sure to note by title any applicable licenses/certifications held by assigned personnel. Indicate with (S) if listed personnel are to be shared with another contract/project. Use additional sheets as necessary to provide a full and comprehensive response.

A description and background of pertinent staff that will be assigned to this project is attached. Staff includes those in Management, IT, specific Project Team Members, and Crew leaders.

1. **Tree Trimming/Maintenance:**
(List labor, administrative, and field supervisory personnel. Include any ISA or equivalent certified personnel)

Please see attached.

IV. PROPOSED PROJECT WORK SCHEDULES

The following page contains a blank Annual Schedule Sheet. Proposers are to complete this schedule sheet by writing in their proposed schedule for performing the work as described in Exhibit A. Use additional sheets as necessary to provide a full and comprehensive response.

A. ANNUAL SCHEDULE SHEET

1. List all tasks specified to be performed for each area, as identified in Exhibit E, in the box corresponding to the months of the year in which you propose to perform the tree trimming/removals and associated services.
2. Be sure to include administrative tasks such as report submittals, meetings, etc.
3. Fill in the schedule sheet for the entire year. Schedule sheets that are not completed for the entire year will be considered to be non-responsive.

PROPOSED PROJECT WORK SCHEDULES
PROJECT NO. 2011 TREE TRIM/REMOVAL
ANNUAL SCHEDULE SHEET

<p>JANUARY</p> <p>2012</p> <p>E-7 & Zone M Monthly Report & Meeting</p>	<p>FEBRUARY</p> <p>2012</p> <p>DSG 2- South & E-14 Monthly Report & Meeting</p>	<p>MARCH</p> <p>2012</p> <p>DSG 2 North Monthly Report & Meeting</p>
<p>APRIL</p> <p>2012</p> <p>E-4 Monthly Report & Meeting</p>	<p>MAY</p> <p>2012</p> <p>E-8 & E-15 Monthly Report & Meeting</p>	<p>JUNE</p> <p>2012</p> <p>E-3 & DSG I Monthly Report & Meeting</p>
<p>JULY</p> <p>2012</p> <p>Monthly Report & Meeting * Contract Renewal * Start of New Schedule</p>	<p>AUGUST</p> <p>2012</p> <p>* New Schedule TBD</p>	<p>SEPTEMBER</p> <p>2012</p> <p>* New Schedule TBD</p>
<p>OCTOBER</p> <p>2012</p> <p>* New Schedule TBD</p>	<p>NOVEMBER</p> <p>2011</p> <p>E-2 & E-16 Monthly Report & Meeting</p>	<p>DECEMBER</p> <p>2011</p> <p>E-1 & E-1A Monthly Report & Meeting</p>

V. COMMUNICATIONS, TRAFFIC SAFETY, & GREENWASTE RECYCLING

A. Communications:

The General Provisions require that the selected Contractor possess, and maintain an effective company-wide communications system. The Contractor must also designate responsible staff to be available on a twenty-four (24) hour basis to receive, and respond to emergency calls.

Describe your company's internal communications system, both in the office and in the field, and how it will enable your company to provide the communication capability as required in Exhibit A, Section 3, letter E, (Functions and Responsibilities). Also, describe how your company will provide the required twenty-four (24) hour communication capability. Use additional sheets as necessary to provide a full, and comprehensive response.

Emergency Response is available 24 hours a day 7 days a week.

Communication is an essential key in the day to day operations; from administrative personnel to field crews. Employees are provided with: cell phone, Nextel radio, email, and/or Sprint EVO tablet.

Prior to commencement of work the Area Manager will make arrangements to inspect all sites under contract and will review the proposed Work Schedule and suggested maintenance requirements with City staff.

The Project Team's goal is to provide efficient communication with the city at all times. The Area Manager and Supervisor will work together in delegating crews while the Customer Service Representative will provide City staff with daily "morning locations" when crews are working within city limits. Adequate up-to-date work records are recorded daily and are available online on WCA's inventory software program, ArborAccess. Adequate work records reflect the billing process. Further details are provided in the attachment.

B. Traffic Safety:

The General Provisions require that the selected Contractor provide safe and effective work area traffic control, per Caltrans' "Manual On Uniform Traffic Control Devices 2010 (or most current) California Supplement, Part 6, Temporary Traffic Control". Please describe your company's general traffic control practices and training, and how your company intends, if selected, to conduct work area traffic control operations to provide service for this project. Use additional sheets as necessary to provide a full and comprehensive response.

Please refer to attachment.

C. Greenwaste Recycling:

AB 939 mandates that the City of Moreno Valley divert from landfills fifty percent (50%) of the solid waste, including greenwaste, generated within its jurisdiction. Please describe your company's program to insure that the City receives credit for the greenwaste that will be generated from executing the project's Scope of Work (Exhibit A). Be sure to include the name(s), address(es) and phone number(s) of the recycling facility(ies) that will be accepting the greenwaste generated from your operations on the project. If planning to use any recycled greenwaste products (mulch, compost, soil amendments, etc.) on the project, please give name/address/phone information of the producer if different from those listed above. Use additional sheets as necessary to provide a full and comprehensive response.

Please refer to attachment.

III. PROPOSED FACILITIES, EQUIPMENT, & STAFFING

A. PROPOSED FACILITIES

HEADQUARTERS

Contact: Victor Gonzalez, Vice President– Marketing
2200 E. Via Burton Street
Anaheim, CA 92806

Phone: (714) 991-1900
Fax: (714) 991-1027
Email: vgonzalez@wcainc.com

REGIONAL OFFICE

Contact: Ernesto Macias, Area Manager
21718 Walnut Avenue
Grand Terrace, CA 92313

Phone: (909) 783-6544
Fax: (909) 783-6574
Email: emacias@wcainc.com

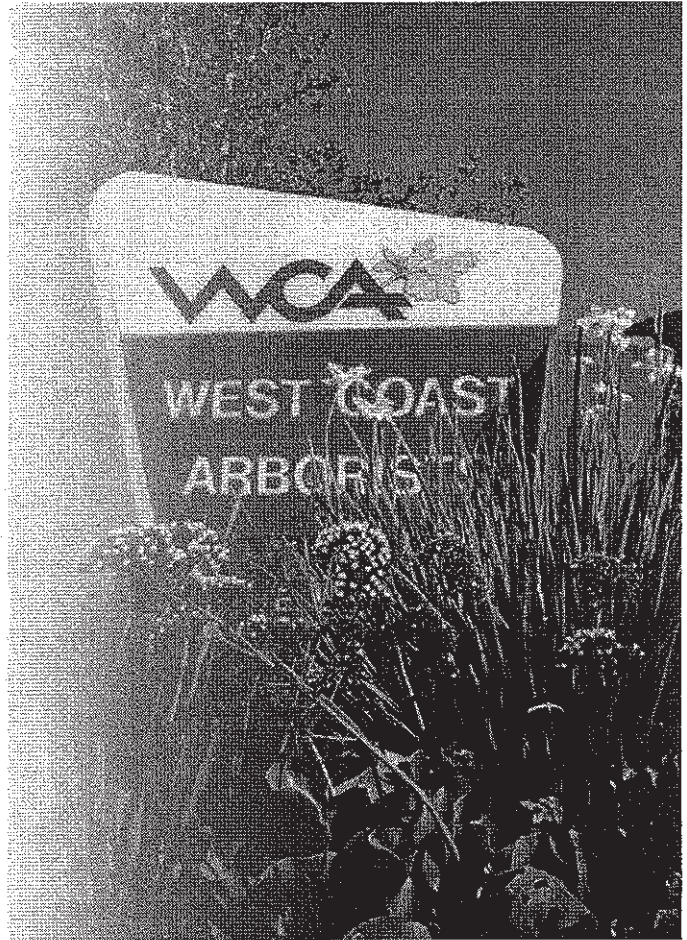

B. EQUIPMENT

Introduction

Our modern fleet consists of nearly 700 vehicles that undergo daily inspection by each driver. All equipment is kept serviced and free of graffiti at all times and is painted and detailed on a regular basis. We have a credit line of \$2 million dollars for the acquisition of new equipment.

WCA's policy is that all employees hold a valid, insurable Driver's License. We are enrolled in the DMV's Employee Pull Notice Program which provides us with a means of promoting driver safety through ongoing review of the driving records of commercial drivers. Our company has been assigned CHP Carrier Number CA68562 in the California Highway Patrol's Management Information System of Terminal Evaluation Records (MISTER), which is an automated file pertaining to the motor carriers operating in the State of California. MISTER gives the CHP immediate access to emergency information about our company and enhances the CHP's capability to monitor the overall safety operations of our company.

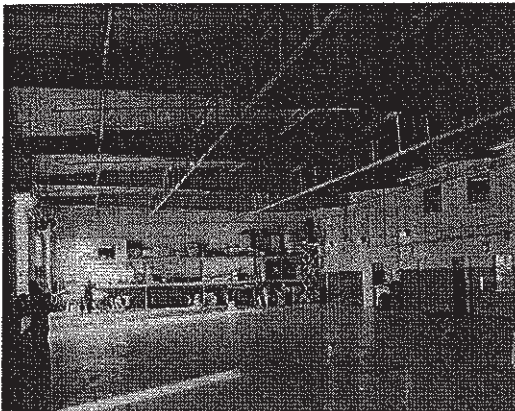
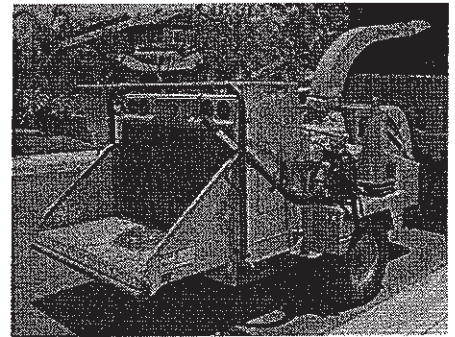

Maintenance Facility

Equipment Maintenance Facility

- We have a state-of-the-art full service Maintenance Department at our corporate headquarters
- WCA has 30 full-time mechanics on staff and a full-time Preventive Maintenance Manager
- 90-day detailed inspections are performed by the WCA Maintenance Department
- Attached are certifications for each aerial tower assigned to the the City. Additional and/or replacement certified aerial towers are readily available for this contract.

PROJECT EQUIPMENT

We currently have more than 700 pieces of fairly new equipment that enables us to replace equipment immediately should there be any unforeseen mechanical problems. We employ thirty full-time mechanics that perform an in-house fleet maintenance program. Each vehicle is schedule for service and inspection every ninety days. This allows our equipment to be in good operating condition necessary for accomplishing the City's needs. Upon request a full list can be made available.

III. PROPOSED FACILITIES, EQUIPMENT, & STAFFING

We believe the success of the project is partly attributed to the dedicated pieces of equipment assigned to the City of Moreno Valley. In addition to aerial lift devices, dump trucks, flatbed trucks and roll-off trucks and containers, we also have additional equipment for use in the City such as cranes, loaders, and special aerial lift devices for higher elevated trees. Specific vehicles and equipment that will be dedicated to the City of Moreno Valley are listed

Year	Make	Model	Body Type	VIN / Serial
2010	Toyota	Prius	Sedan	JTDKN3DUXA1082372
2009	Toyota	Prius	Sedan	JTDKB20U693491865
2009	GMC	C7500 /HI-RANGER 5FC-60	Boom Truck	1GDJ7C1G19F408770
2009	GMC	C7500 /HI-RANGER 5FC-60	Boom Truck	1GDJ7C1G49F408813
2009	GMC	C7500 /HI-RANGER 5FC-60	Boom Truck	1GDJ7C1G29F409099
2009	GMC	C7500 /HI-RANGER 5FC-60	Boom Truck	1GDJ7C1G19F408722
2009	GMC	C7500 /HI-RANGER 5FC-60	Boom Truck	1GDJ7C1G39F409029
2008	GMC	C7500 /HI-RANGER 5FC-60	Boom Truck	1GDJ7C1G29F407417
2008	GMC	C7500 /HI-RANGER 5FC-60	Boom Truck	1GDJ7C1G69F407484
2008	Chevy	2500 Service Truck	Truck	1GBHC24KX8E100837
2006	Dodge	Ram 2500	Pickup	3D7KR26D86G202972
2006	Dodge	Ram 2500	Pickup	3DJKR26D56G249229
2006	Dodge	Ram 2500	Pickup	3D7KR26D26G251701
2006	Dodge	Ram 2500	Pickup	3D7KR26DX6G265801
2006	Dodge	Ram 2500	Pickup	3D7KR26D76G275864
2006	Dodge	Ram 1500	Pickup	3C7KR26D56G275863
2006	Dodge	Ram 2500	Pickup	3D7KR26D56G277872
2006	Dodge	Ram 2500	Pickup	3D7KR26D36G275862
2007	GMC	C7500	Dump Truck	1GDJ7C1G17F409091
2007	GMC	C7500	Dump Truck	1GDJ7C1G27F409228
2007	GMC	C6500	Dump Truck	1GDJ7C1G68F402915
2007	GMC	C6500	Dump Truck	1GDJ7C1G68F403143
2007	GMC	C6500	Dump Truck	1GDJ7C1G18F402921
2007	GMC	C6500	Dump Truck	1GDJ7C1GX8F403209
2004	Ford	F450	Flatbed	1FDXF46SX4ED21724
2007	Vermeer	BC1800XL	Brush Chipper	1VRY131Z281002255
2006	Vermeer	BC1400	Brush Chipper	1VRU1614661003409
2006	Vermeer	BC1400	Brush Chipper	1VRU1614861003136
2006	Vermeer	BC1800	Brush Chipper	1VRY131Z361001337
2006	Vermeer	BC1800XL	Brush Chipper	1VRY131Z861001334
2006	Vermeer	BC1800XL	Brush Chipper	1VRY131ZX61001321
2005	Vermeer	BC1800XL	Brush Chipper	1VRY131Z151000752
2007	Vermeer	802	Stump Grinder	1VR2161J561000279
2005	Vermeer	752	Stump Grinder	1VRN151U051001197
2005	Vermeer	1102	Stump Grinder	1VRN1513451002005
2002	Dosko	691SP	Grinder	0105-02-4356
2005	Caterpillar	287	Skid Steer Loader	0CNY00926
2006	Bobcat	S185	Loader	530314834
2005	Bobcat	S185	Loader	525022994
2002	Bobcat	773T	Loader	519023882

III. PROPOSED FACILITIES, EQUIPMENT, & STAFFING

EQUIPMENT LIST SUMMARY

- Pick Up Trucks 170
- Aerial Lift Devices 170
- Arrowboards 35
- ATVs 2
- Backhoe 1
- Brush Chippers 112
- Cranes 4
- Dump Trucks 101
- Flat Beds 14
- Forklifts 3
- Stump Grinders 28
- Loaders 35
- Rubber Track Loader 1
- Root Pruners 2
- Rolloff Trucks 27
- Saw Mill 1
- Log Skidder 1

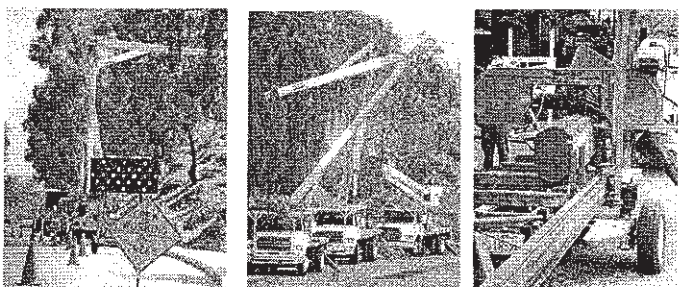
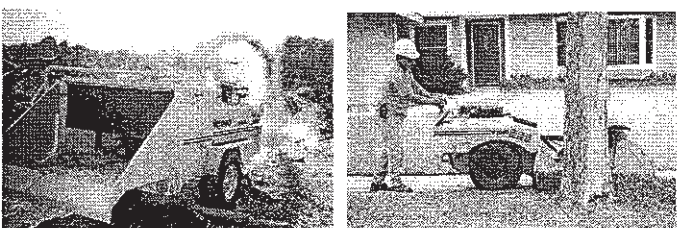
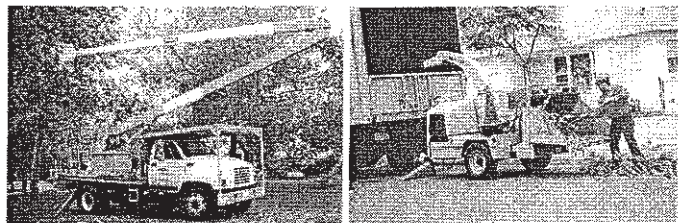
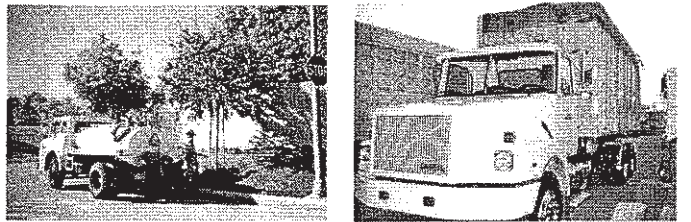
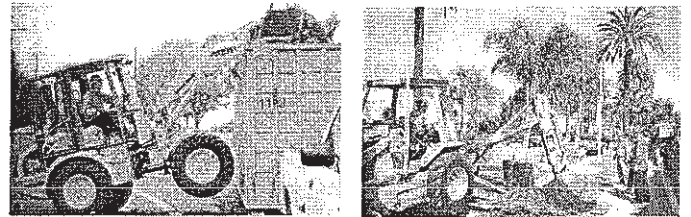
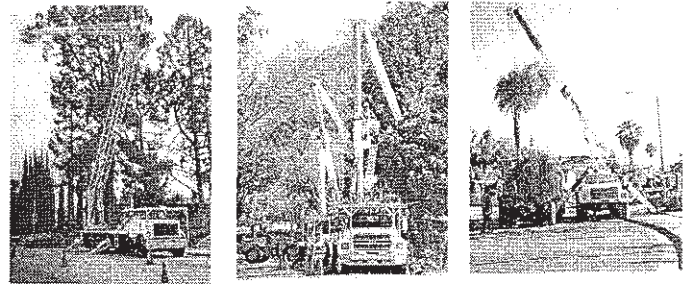

III. PROPOSED FACILITIES, EQUIPMENT, & STAFFING

C. STAFFING

PATRICK O. MAHONEY President

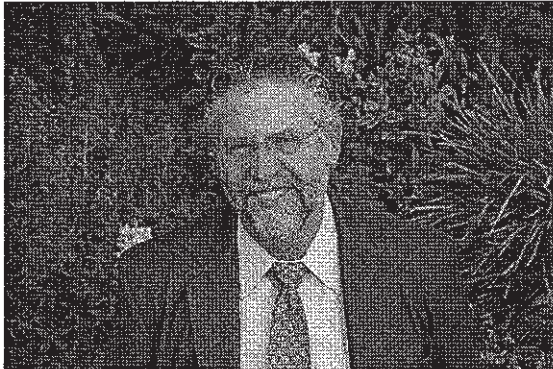

Professional Registration
California State Contractors License
#313843, Class C61 & C27
ISA, Certified Arborist #WE-1172A



Mr. Mahoney founded West Coast Arborists, Inc. in 1972. As President and Chief Executive Officer, Mr. Mahoney oversees the complete operation of the company. Under his direction the company has grown from 3 employees and 2 trucks to over 550 employees with a 500 plus unit fleet. In December of 2009, the Anaheim Chamber of Commerce honored Patrick as the "Business Champion of the Year" for 2009. The Business Champion of the Year Award recognizes an individual who uses their professional expertise and talents in activities that promote business and the Anaheim community.

Professional Affiliation

Founder - So. California Tree Trimmers Jamboree
Past President and Honorary Lifetime Member - Western Chapter ISA
Served 1989-97 - ISA Certification Committee
Award of Merit - Western Chapter ISA, 1997
Award of Achievement - ISA, 1998
Society of Commercial Arborists
Municipal Arborists Association
Street Tree Seminar
Tree Care Industry Association
Maintenance Superintendents Association
Utility Arborists Association
California Oak Foundation
The Palm Society

ROSE M. EPPERSON Vice President



Professional Registration
California State Contractors License
#654265, Class C61 & D49
ISA, Certified Arborist #WE-1045A
American Society of Association Executive
B.S., Business Administration, *Argosy University, Costa Mesa, CA*

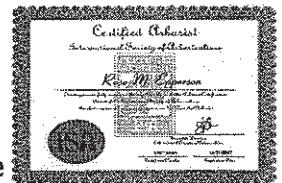

Mrs. Epperson has been with West Coast Arborists, Inc. since August 1979, and she has been a director at WCA since 1992. Her experience lies in accounting and administration. She is responsible for administrative and accounting functions on a corporate level. She has been involved in the implementation and management of our computerized accounting, estimating and job costing programs.

RICHARD MAHONEY **Vice President**



Professional Registration
ISA, Certified Arborist #WE-1171A
B.S., Business Administration, *University of Houston*, Houston, Texas



Mr. Mahoney has been with West Coast Arborists, Inc. since 1974 and has over 30 years experience in the tree care industry. He is responsible for internal operations, management of our fleet including maintenance and repairs, as well as overseeing facilities, supplies and purchasing. Prior to his present position with WCA, he spent two years as Vice President of Operations for Golden Coast Environmental Services, a computer oriented urban forestry consulting firm in Irvine, CA. With extensive background in information systems management, Mr. Mahoney oversees the computer operations of WCA. In addition he has served as a member of the Board of Directors since 1978. He receives a minimum of 25 hours credit annually in arboriculture continuing education credits.

RANDY THOMPSON **Vice President/Area Manager**



Professional Registration
ISA, Certified Arborist #WE-1043A

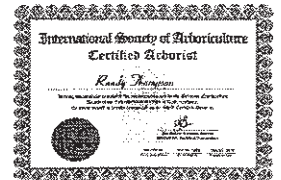

Mr. Thompson has been with West Coast Arborists, Inc. since September of 1978. He has over 30 years experience in the arboriculture field. Responsibilities within the company are broad. He is responsible for estimating, scheduling, contract administration, personnel and daily operations. As an Area Manager, he is responsible for field operations, customer service, and management of crews throughout Orange County. Through his employment he has gained valuable experience in computer estimating, tree inventory systems, and costing programs which are essential in the efficient operation of tree care crews. He receives a minimum of 25 hours credit annually in arboriculture continuing education credits.

ANDREW R. TROTTER **Vice President, Field Operations Manager**



Professional Registration
ISA, Certified Utility Arborist #WE-642AU
California Urban Forests Council, Certified Urban Forester #103
TCIA, Certified Tree Care Safety Professional, #142
Wildlife Training Institute, Certified Wildlife Protector #533

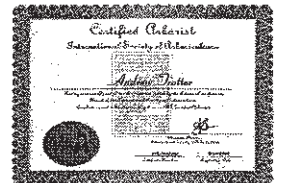

Mr. Trotter has been with West Coast Arborists, Inc. since August of 1982. Prior to that, he had eight years experience in the tree care industry. After working as a Foreman for eight years, Mr. Trotter was promoted to Field Operations Manager in March of 1990. As Field Operations Manager, he supervises all of the field operations as well as overseeing our safety, training, nursery and wood recycling facility. He has been an industry leader in many key projects including United Voices for Healthier Communities Great Clean Air Planting Project, Toolkit for Developing Urban Forest Management Plans and the Western Chapter ISA's annual "Workday" fundraiser.

III. PROPOSED FACILITIES, EQUIPMENT, & STAFFING

DEBORAH DEPASQUALE Vice President, Contract Services



Professional Registration

ISA, Certified Arborist #WE-3812A

B.A., Entrepreneurial Management minor in Political Science, *California State University Fullerton*, Fullerton, CA Employee of the Year, WCA 1995

Ms. DePasquale has been with West Coast Arborists, Inc. since November of 1993. Before that time, she worked as a consultant for WCA and was a Senior Account Executive for a finance company for five years. Her responsibilities include managing Customer Service, Billing, Administration and Human Resources. Ms. DePasquale has over 20 years computer experience and 17 years in the tree care industry. She receives a minimum of 25 hours credit annually in arboriculture continuing education credits.

CHRISTOPHER CRIPPEN Vice President, MIS



Professional Registration

Microsoft Certified Professional

Mr. Crippen has been with West Coast Arborists, Inc. since October of 1995. At that time, he had four years experience as a computer programmer for an insurance company. As a computer programmer, he supports the tree inventory software created by WCA, as well as customizes each software package for each County. In addition, he maintains the inventory databases compiled by the Inventory Specialists. He has over 18 years computer programming experience

and over 14 years experience in the tree care industry.

VICTOR GONZALEZ Vice President, Marketing

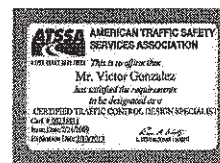

Professional Registration

ISA, Certified Arborist #WE-7175A

ATSSA, Certified Traffic Control Designer #00236811

B.S., Engineering Technology – Construction Management, *California State University, Long Beach*, Long Beach, CA Employee of the Year, WCA 2009

Mr. Gonzalez has been with West Coast Arborists, Inc. since June of 1999. During the previous two years, he worked as a Public Works Inspector for a private engineering firm serving cities in Orange and Los Angeles Counties. Before that time, he served the City of Bellflower for four years as an Executive Assistant to the Director of Public Services. His responsibilities included contract administration, project management, and customer service within the Public Services Department. He has over seven years of city government and public works experience and 11 years in the tree care industry. He is a member of the firm's Management Team that provides strategic leadership and business development. He leads the sales force in developing its customer base and strategic marketing plans. He oversees the procurement of company's annual insurance policy coverage and oversees contracts with nearly 200 customers including all contract negotiations.

III. PROPOSED FACILITIES, EQUIPMENT, & STAFFING

REBECCA MEJIA Arborist



Professional Registration

ISA, Certified Arborist #WE-2355A

B.S., Urban Forestry and Natural Resource Management, *Cal Poly San Luis Obispo*, San Luis Obispo, CA

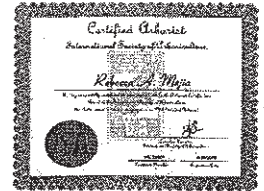

Mrs. Mejia has been with West Coast Arborists since November of 1995. Before that time, she worked for the U.S. Department of Forestry as a Recreation Technician. Her current responsibilities as a Consulting

Arborist include preparing Arborist Reports, Tree Appraisals and performing Tree Hazard Evaluations for our clients. In addition, she develops master street tree planting programs and recommends species. Mrs. Mejia currently has over 15 years experience in the tree care industry. She receives a minimum of 25 hours credit annually in arboriculture continuing education credits.

BRIAN KOCH Inventory Specialist



Professional Registration

ISA, Certified Arborist #WE-341A

B.S., Ornamental Horticulture, *Cal Poly Pomona*, Pomona, CA

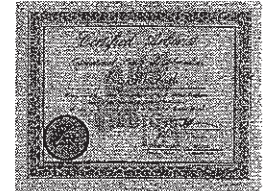

Mr. Koch has been with West Coast Arborists, Inc. since November of 2000. Before that time, he worked for Davey Resource Group as a Data Collector inventorying trees throughout North America including Hawaii. His responsibilities include collecting tree site information for

building databases. In addition, he develops master street tree planting programs and recommends species. Mr. Koch currently has over 25 years experience in the tree care industry and is member of the ISA and the Southern California Turfgrass Council. He receives a minimum of 25 hours credit annually in arboriculture continuing education credits.

RENE PORTILLO Safety Trainer



Professional Registration

ISA, Certified Tree Worker #579C

ISA, Certified Utility Arborist #WE-2038AU

ATSSA, Certified Traffic Control Supervisor #00227843

TCIA, Certified Tree Care Safety Professional #CTSP-137

NCCCO, Certified Crane Operator #051223269



Mr. Portillo has been with West Coast Arborists, Inc. since September of 1993. As the Safety Trainer, he is responsible development, implementation and review of in-house training programs utilized for new hire and existing employees. These programs include administering certification training, crew leader training, commercial license, etc. He is also responsible for the Injury and Illness Prevention Program (IIPP), crew safety audits as well as follows up on safety improvement plans if accidents or incidents occur. Mr. Portillo has over 18 years experience in the tree care industry. He receives a minimum of 40 hours credit annually in arboriculture continuing education credits.

III. PROPOSED FACILITIES, EQUIPMENT, & STAFFING

PROJECT TEAM

ERNESTO MACIAS

Area Manager, South East Inland Empire



Professional Registration

ISA, Utility Certified Arborist #WE-7120AU

Mr. Macias has been with WCA since August of 2011. Before that time, he worked with The Davey Tree Expert Company. Mr. Macias started as a Groundman and worked his way up. After 8 years he was promoted to an Account Manager where he managed over 120 employees and was responsible for day to day operations. Today at WCA, Mr. Macias is responsible for field operations and management of crews in both

Riverside and San Bernardino counties. He is also involved in scheduling, evaluation and production of street tree maintenance. Mr. Macias has over 15 years' experience in the tree care industry.

ANGEL RINCON

Site Supervisor

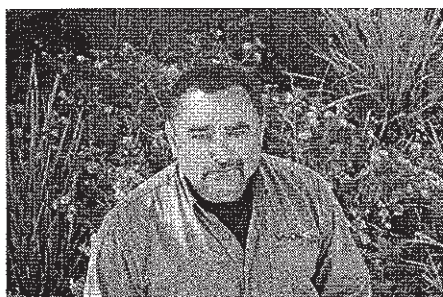

Professional Registration

ISA, Certified Treeworker Climber #1116C

WCA Qualified Arborist

Mr. Rincon has been with West Coast Arborists, Inc. since 1998 and has over 20 years field experience in the industry. As Site Supervisor, Angel is a full-time employee and speaks fluent English. He is responsible for reviewing the day's activities, assisting the Area Manager in scheduling,

and insuring proper safety procedures are being followed. As Supervisor, Angel is to communicate with city officials and other interested parties on a daily basis. Report and resolve malfunctions, damage, or industrial injury. He assists in employee training programs, maintains records, and files daily reports and receipts.

ESTHER CADMAN

Office Manager/Customer Service Representative

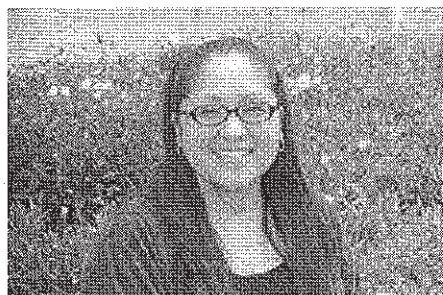

As the CSR (Customer Service Representative), Esther is responsible for providing support to the Area Manager, Site Supervisor, and crew. The CSR is to act as a liaison between the company and it's clients as well as the general public. The CSR is responsible for responding to Customer Service inquiries and facilitating contracting functions, such as: mapping underground service alert, data entry, field book preparation, list preparation, public relations, errands, etc.

PEST CONTROL ADVISOR AND APPLICATOR

California Agriculture Production Consultants Association (CAPCA) is a professional association that promotes and educates the licensed Pest Control Advisor (PCA), thereby fostering the highest quality pest management standards while recognizing our responsibility to the public, our employees, and the environment.

Jason Davlin, Pest Control Applicator #PA-30-00170

Paul Webb, Pest Control Advisor #QL02023

PROJECT TEAM FOR CITY OF MORENO VALLEY:

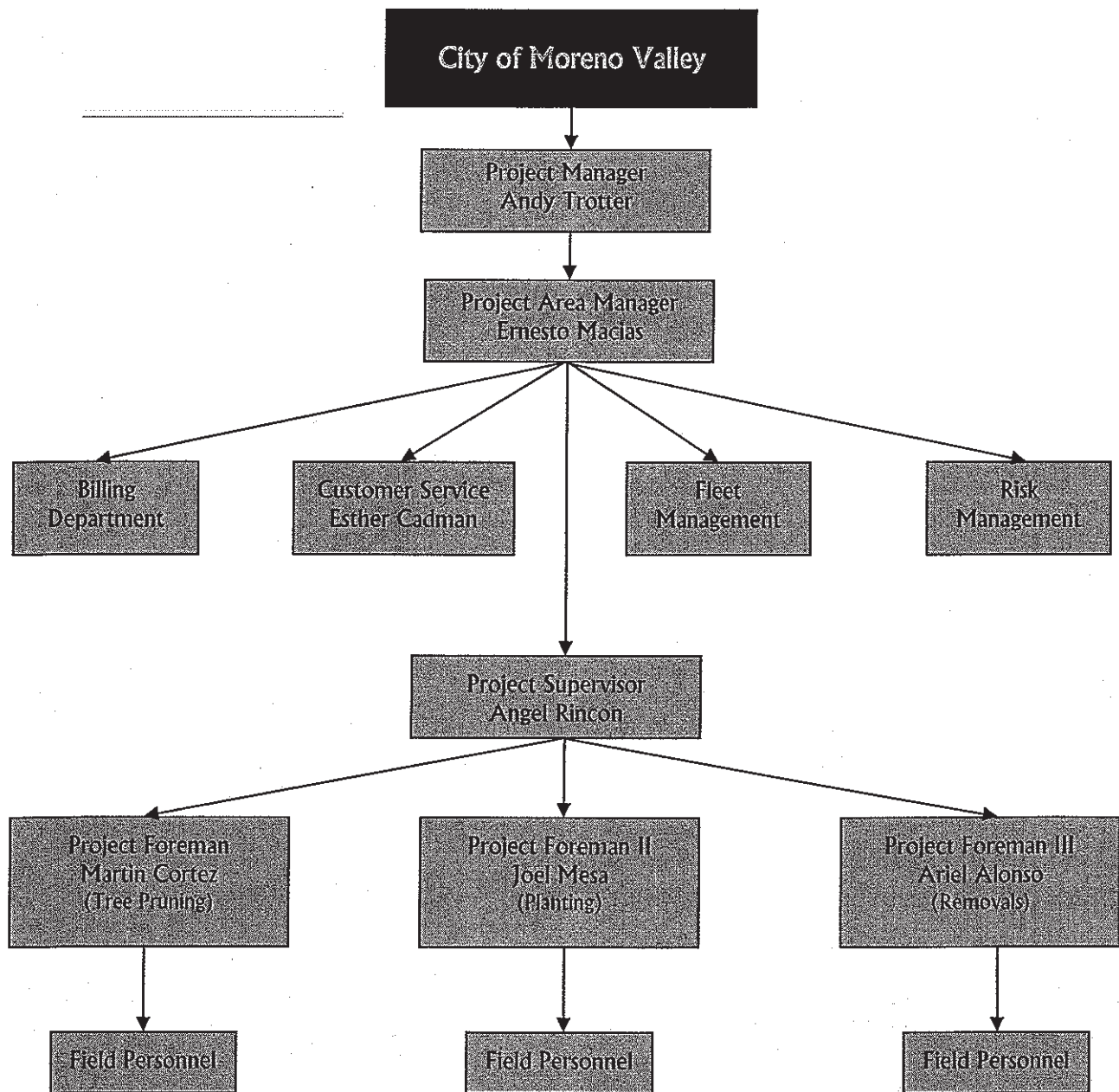

III. PROPOSED FACILITIES, EQUIPMENT, & STAFFING

CERTIFIED ARBORISTS

International Society of Arboriculture Arborist Certification provides an educationally challenging program designed to upgrade the knowledge and proficiency levels in the tree care profession. Having an I.S.A. Certified Arborist oversee the project is vital for the quality and craftsmanship of proper urban tree care. Our Arborists accumulate 10 Continuing Education Units (CEUs) annually, which help to ensure that they are keeping up with the latest research and techniques. Below is a list of our I.S.A. Certified Arborists:

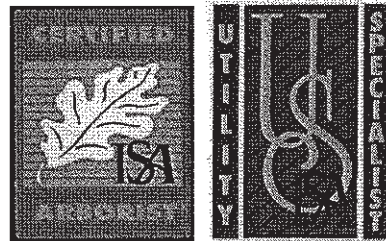

J. Nick Alago *	WE-4396AU	Brian Koch	WE-0341A	Michael Palat *	WE-6541AU
Robert Barr	WE-1401A	Lita Lira	WE-1906A	Lorenzo Perez	WE-7443A
Joseph Bartolo *	WE-2034AU	Ignacio Lopez	WE-7329A	Jason Pinegar *	WE-2039AU
David Cooper	WE-0497A	Jorge Magana	WE-3460A	Rene Portillo *	WE-2038AU
Jason Davlin	WE-7628A	Patrick Mahoney	WE-1172A	Frank Quinn	WE-1085A
Deborah DePasquale	WE-3812A	Richard Mahoney	WE-1171A	Adan Reynaga	WE-7786A
Al Epperson *	WE-0719AU	Gail Manzanedo	WE-3858A	Rene Rosales	WE-7941A
Rose Epperson	WE-1045A	Rebecca Mejia	WE-2355A	Randy Thompson	WE-1043A
James Goss	WE-1042A	Filandro Menjivar *	WE-7014AU	Robert Thompson *	WE-0915A
Victor Gonzalez	WE-7175A	Hector Montes	WE-8079A	Andrew Trotter *	WE-0642AU
Felix Hernandez	WE-2037A	Michael Morris	WE-1095A	Jeffery Williams	WE-1100A
Steve Hunt	WE-1044A	Herminio Padilla *	WE-7552A	J. Charles Working	WE-1592A

* denotes Utility Specialist designation

CERTIFIED TREEWORERS

The purpose of the ISA Treeworker Certification is to establish a meaningful standard of skill and work quality, to establish and measure a level of training and knowledge, to encourage continuing education, and to promote safe work practices. In an effort to provide the best possible urban tree care, WCA hires, trains and assigns Certified Tree Workers for our projects. This insures that a minimum level of training and knowledge for arboriculture has been obtained and that safe work practices and overall safety will be performed. We ensure continuing education and training for those Tree Workers who may wish to gain knowledge in arboriculture or who may want to become Certified Arborists. Below is a list of our Western Chapter I.S.A. Certified Tree Workers:



Jose Luis Abalos	1472	Faustino Espinosa	1510	Jose I. Mancilla	1299	Adan Reynaga	0435
Jose Aguayo	1050	Pedro B. Fuentes	1547	Juan Marquez	0430	Hugo Angel Rincon	0614
Nelson Aguirre	1460	Gabriel Gamino	1051	Eduardo Martinez	1087	Joel M. Rivera	1206
Ariel Alonso	0489	Felix Garcia	1003	Joel Martinez	1447	Adam Rodriguez	0493
Jose A. Alvarez	1497	Ventura Gomez	1190	Marcos R. Martinez	1661	Jose Rodriguez	0594
Salvador Avelar	1278	Antonio Gradilla	0971	Varaquiuel Martinez	0431	Teodoro Rodriguez	1207
Eduardo Avila	0420	Jose Guardado	1665	Filandro Menjivar	1075	Valentin Roman	1402
Saul G. Avila	0421	Raymundo Gutierrez	1074	Alberto J. Monterosa	1400	Rene Rosales	1259
Manuel Barragan	1461	Fausto Guzman	1116	Hector Montes	1296	Isaias Sanchez	1073
Martin Barrera	1136	Felix Hernandez	0424	Jesus A. Montes	0583	Salustio Sanchez	1508
Eugene Barrientos	1712	Pedro A. Hernandez	1503	Michael Morris	0240	Enrique Sandoval	1272
Juan Becerra	0637	Rafael Hernandez	1192	Rene Nunez	1141	Salomon Silva	0858
Manuel Briano	1606	Steve Hunt	0426	Jorge Orozco	1026	Ruben Soriano	1286
Jose Abel Cancino	1663	Elijio Ibarra-Cardoso	1070	Joel Ortiz	0993	Miguel Angel Soto	1432
Manuel Candelario	0577	Carlos Ixta	1052	Juan Ortiz	1505	Juan Tellez	1656
Agustin Carrillo	1097	Jorge Jiminez	0990	Demetrio Oseguro	1008	Robert Thompson	0219
Antonio Castellanos	0491	Jose Jiminez	1076	Marco A. Padilla	1603	Jose Irene Vega	1174
Ruben Comejo	1110	Lita Lira	0426	Aurelio Paz-Guzman	1191	Jose Trinidad Vega	1164
Camerino Coronel	1297	Alfredo A. Lopez	0925	Celestino Perez	1120	Marco A. Vergara	1465
Jose Luis Coronel	0851	Armando Lopez	1255	Lorenzo Perez	0781	Francisco Villanueva	1552
Leonel Cortez	1188	Francisco Lopez	0992	Rene Portillo	0579	Cesario Wenceslao	1011
Pedro Cuevas	1001	Juan Lopez	1431	Martin Quintero	0644	Jeffery Williams	0437
Jorge Duenas	1002	Sergio Lopez Rivera	1103	Francisco Ramirez	1009	J. Charles Working	0647
J. Refugio Escamilla	1268	Miguel Maclas	1024	Ramon Ramirez	1069	Walter E. Zaldana	1529
				Daniel Rivas	1609		

III. PROPOSED FACILITIES, EQUIPMENT, & STAFFING

CERTIFIED URBAN FORESTER

The California Urban Forests Council's Certified Urban Forester program recognizes, encourages, and enhances the education, experience and professional status of urban forestry professionals, while providing agencies, organizations, and companies that utilize their services a benchmark for identifying qualified professionals. The Certified Urban Forester Program grants certification to individuals who meet both educational and professional prerequisites and have compiled with the requirements, including passing a required certification examination. The requirements correspond to knowledge, abilities, skills and experience commensurate with the professional practice of urban forestry.

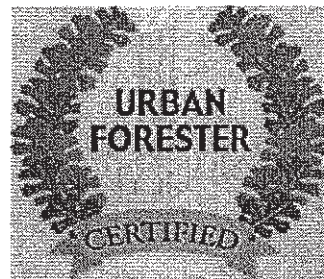

Andrew R. Trotter, Certified Urban Forester #103, California Urban Forests Council

CERTIFIED TREECARE SAFETY PROFESSIONAL

The Tree Care Industry Association (TCIA) accredits tree companies, develops safety and education programs, establishes standards of tree care practice and provides management information for arboricultural firms around the world. Our purpose for having Certified Treecare Safety Professionals (CTSP) is to improve worker safety by empowering and encouraging the development of a culture of safety. Currently, WCA has the greatest number of Certified Treecare Safety Professionals in the state of California and they are listed as follows:

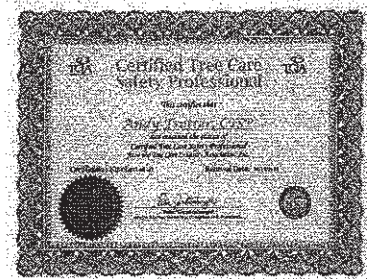

- Andrew R. Trotter, Certified Treecare Safety Professional #142
- Frank Quinn, Certified Treecare Safety Professional #562
- Angel Rincon, Certified Treecare Safety Professional #763
- Hermínio Padilla, Certified Treecare Safety Professional #139
- James Charles Working, Certified Treecare Safety Professional #141
- Juan Marquez, Certified Treecare Safety Professional #143
- Rene Portillo, Certified Treecare Safety Professional #137
- Veronica King, Certified Treecare Safety Professional #140



ATSSA CERTIFIED TRAFFIC CONTROL

The American Traffic Safety Services Association (ATSSA) provides quality roadway safety education and training. Their progressive and innovative approach to training and education has made them the state-recognized leader in traffic control safety. The following employees hold designated certifications:



- | | |
|--|--|
| Victor Gonzalez, Traffic Control Design Specialist #00236811 | Jason Pinegar, Traffic Control Design Specialist #236727 |
| Rene Portillo, Traffic Control Supervisor #00227843 | Hermínio Padilla, Traffic Control Technician #00228618 |
| Juan Marquez, Traffic Control Technician #00228625 | Romualdo Gaeta, Traffic Control Technician #00233729 |
| Chuck Working, Traffic Control Technician #00228622 | Robert Barr, Traffic Control Technician #00228623 |

CERTIFIED CRANE OPERATOR

As of June 1, 2005, crane operators in California must be certified, as required by 8 California Code of Regulations §5006.1. The regulations require certification of fixed and mobile crane operators. West Coast Arborists, Inc. currently has five certified crane operators and is currently training other WCA employees for the certification.

- | | |
|------------------------------------|-------------------------------------|
| Hector Montes, NCCCO #060123869 | Joseph Nick Alago, NCCCO #051223266 |
| Hermínio Padilla, NCCCO #060325578 | Michael Morris, NCCCO #051223268 |
| Jason Pinegar, NCCCO #050820987 | Rene Portillo, NCCCO #051223269 |
| Jeffery Williams, NCCCO #080339583 | Steve Hunt, NCCCO #050518883 |



A. COMMUNICATIONS

INTRODUCTION

West Coast Arborists includes with its comprehensive tree maintenance program a well defined quality control plan that incorporates certified personnel assigned to this project, safety, pruning specifications and guidelines, equipment, hours of operation, public relations, traffic control, work descriptions and communication systems. We believe in following this plan to help ensure the quality of work and the level of service expected.

PROJECT MANAGER

Andrew R. Trotter will act as the Project Manager for this project. Mr. Trotter holds ISA Certified Arborist Number 642. With over thirty years experience in the tree care industry, Mr. Trotter will provide overall supervision and coordination of the Area Manager and Field Operations. He has full authority to act on behalf of West Coast Arborists, Inc. on all contract matters.

PROJECT AREA MANAGER

The Project Area Manager for this contract will hold an ISA Certified Arborist certificate. With several years of experience in the tree care industry, the Project Area Manager will provide exclusive field supervision and crew management to the City for the length of the contract. They will be the central point of contact with the City and will work cooperatively with City staff, local residents and business owners. During the past thirty years, our Project Area Managers have successfully worked with several cities and established a familiarity with the community and logistics of each City respectively.

Daily Supervision

Daily supervision will consist of, but is not limited to:

- Report to the City Inspector with location of crew and maintain an open line of communication
- Supervise crew personnel to insure proper pruning standards are followed in a safe manner
- Traffic control setup and maintenance of coned area
- Insure City streets are left free of any debris at end of each work day
- Maintain record of work completed each day
- Maintain good public relations at all times
- Immediate notification to City Inspector upon damage of personal property including a plan for corrective measures to take place within 48 hours

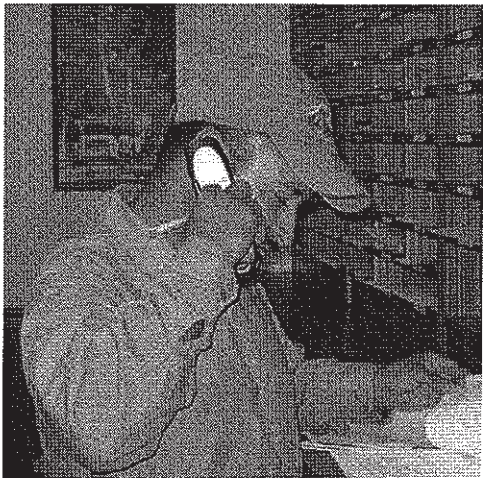

Weekly Supervision

Weekly supervision will consist of, but is not limited to:

- Weekly inspection of work completed
- Meeting with the City to review work schedule and progress
- Insure standards of pruning are performed in accordance with specifications provided by the City
- Maintain open communication with City Inspector and field crew

PROJECT WORK FORCE



- WCA is a professional organization and employ only the highest standard of tree care professionals
 - All employees will comply with any applicable laws of the State, County, City and/or political subdivision of such state without limitations while under contract
 - WCA does not discriminate against employees or applicants because of race, color, religion, sex, pregnancy, national origin, ancestry, age, marital status, or physical handicap
 - Equal opportunity will be extended to all persons in all aspects of the employer-employee relationship, including but not limited to hiring, transfer, promotion, training, compensation, layoff, recall or termination
 - Employment decisions comply with all applicable laws prohibiting discrimination and comply with Title VII of the Civil Rights Act of 1992 and all federal, state and municipal laws pertaining thereto
- Any employee who is found to be incompetent, troublesome, disorderly or otherwise objectionable, or who fails or refuse to perform work properly and acceptable, will immediately be removed from working on this project

HOURS OF WORK AND OPERATION

All regular tree care will be performed between the hours of 7:00 a.m. and 5:00 p.m., Monday through Friday. In accordance with the City's specifications, we are prepared to perform work during the weekend and evenings. With our large number of employees, we are able to create special weekend teams and night teams that are accustomed to performing during those shifts. Oftentimes these special shifts help to alleviate traffic and pedestrian congestion that may otherwise occur during normal business hours.

SCHEDULING OF WORK

The project shall conform to the City's schedule of performance. We recommend equal distribution of work throughout the course of the fiscal year. West Coast Arborists, Inc. will notify the City of any changes in the start date of each tree maintenance operation at least 24 hours in advance, weather permitting. Our company tracks lists according to work type and prioritizes accordingly. West Coast Arborists, Inc. will provide door hangers that explain the tree maintenance process (acceptable to the City) and distribute the notifications to citizens prior to the start of pruning operations in said area. Work shall be conducted in a cooperative manner as to cause the least amount of possible interference with or annoyance to others. Service request pruning is done on an "as needed" basis and is performed to rectify and immediate problem, a full trim will be completed during the grid pruning cycle. The Area Manager is responsible for scheduling the work, a detailed workflow process is shown on the following page, outlining how work is processed and scheduled.

THE WORKFLOW PROCESS

When work is ordered from WCA we follow standard procedures for each. Shown below are flowcharts for pruning, removals and planting:

GRID PRUNING FLOWCHART

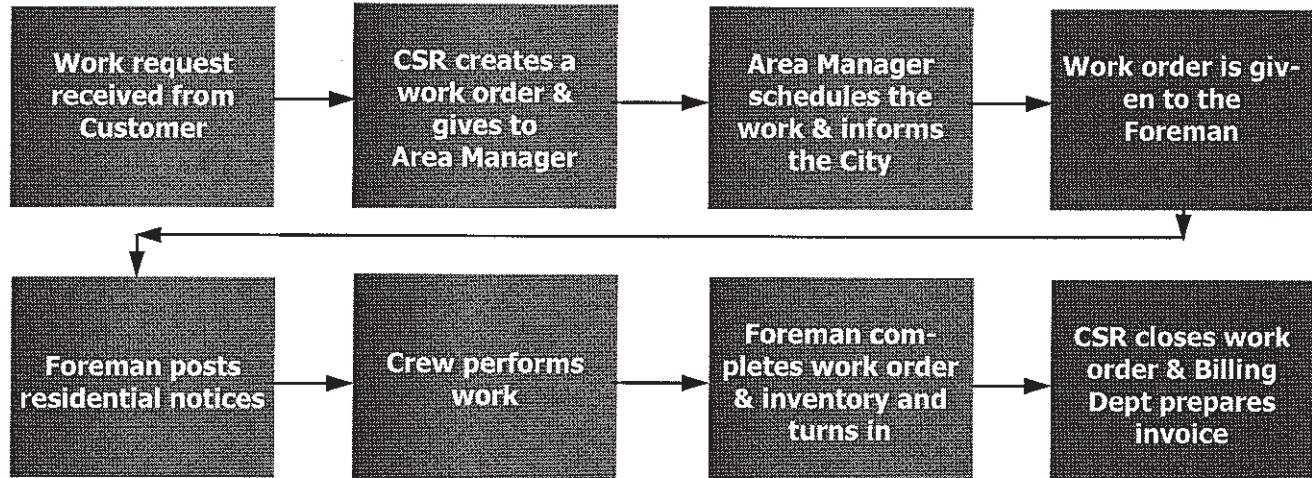

REMOVAL FLOWCHART

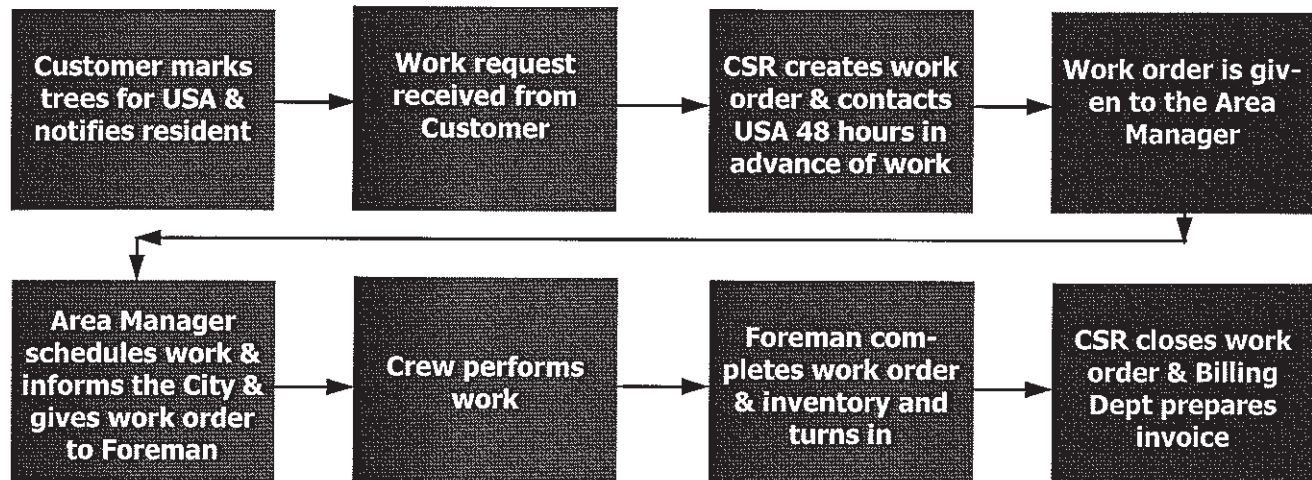

PLANTING FLOWCHART

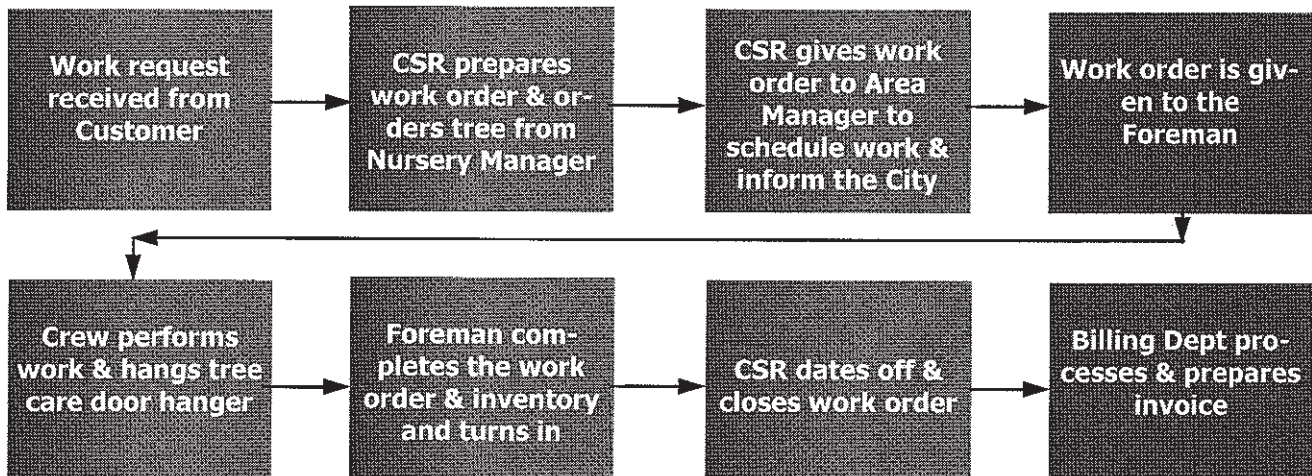

PUBLIC NOTIFICATION

Prior to commencement of grid pruning, WCA will prepare a sample door hanger notice and present it to City staff for approval. Upon approval, we will have the pruning door hangers printed and post them within twenty-four (24) hours prior to the commencement of work, or as directed by the City. Tree planting door hangers will be hung after the tree has been planted. When requiring a response pertaining to tree planting, we will send a letter along with a return postcard to the resident and respectfully request their input. The City should notify WCA if they would like a mailer sent. We will print all notices (and photos for tree planting operations) and distribute them to the residents utilizing a mail addressing software program. Each notice will be sent utilizing City letterhead and envelopes. For special projects and/or routine maintenance, we can also submit a press release to the community newspaper for a more comprehensive outreach. We understand the City may modify the procedure to which to notify residents.

SAMPLE NOTICE

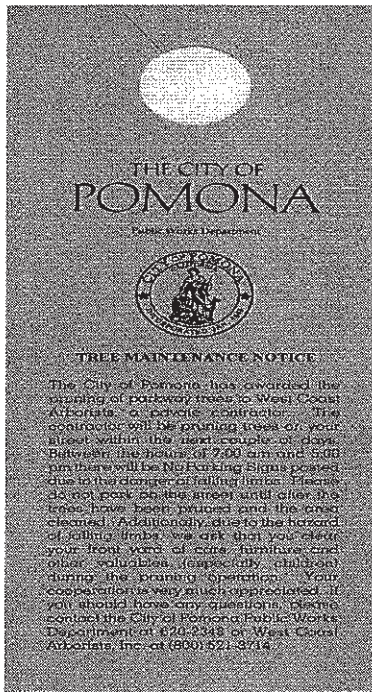

Emergency tree removal operation

COMMUNICATION SYSTEMS

- WCA uses a technologically modern and reliable communications system
- NEXTEL® Digital Radio/Blackberry® email and Internet issued to Area Managers and management team
- NEXTEL® Digital Radio issued to Foremen for maintaining communication with the City and WCA office
- Unlimited access to voicemail message boxes that immediately page the NEXTEL® Digital Phone Systems
- Sprint EVO tablets

EMERGENCY RESPONSE

West Coast Arborists has an Area Manager on call 24 hours a day, 7 days a week, including holidays. The toll free number is 866-LIMB-DOWN (866-546-2369). This number will be provided to the City, Police Department and Fire Department. We will be prepared for emergency calls on a 7-day, 24-hour basis. Our emergency response team will do what is necessary to render the hazardous tree or tree-related condition safe until the following workday. Should the emergency call out occur during normal business hours, contact your Area Manager or Customer Service Representative and one of our teams will respond to the scene and perform the necessary work.

B. TRAFFIC SAFETY

West Coast Arborists, Inc. will set up all traffic control procedures in accordance with the Work Area Traffic Control Handbook (W.A.T.C.H.) and State of California Manual of Traffic Controls as well as the City Traffic and Safety Operating Rules. During the progression of work, WCA will make adequate provisions to insure the normal flow of traffic over the public streets and park roads. Every effort will be made to keep commercial driveways and passageways open to the public during business hours. High visibility arrowboard(s) will be used when needed. Prior to use, the City will approve traffic safety equipment and devices. Pedestrian and vehicular traffic shall be allowed to pass through the work areas only under conditions of safety and with as little inconvenience and delay as possible. Unless the work area is totally barricaded or otherwise kept safe, at least one worker will serve to coordinate safe operations on the ground at all times when work operations are in progress.

EMPLOYEE TRAINING PROGRAM

West Coast Arborists, Inc. provides an extensive in-house training curriculum for all employees to broaden their knowledge of the arboriculture field of study. Included in this training are the ISA standards, both Treeworker and Arborist study programs, and a variety of Tree Care Industry Association home study programs. We also offer training courses to our staff in areas of customer service satisfaction, maintaining professional conduct, and Qualified Line Clearance Trimmer Training.

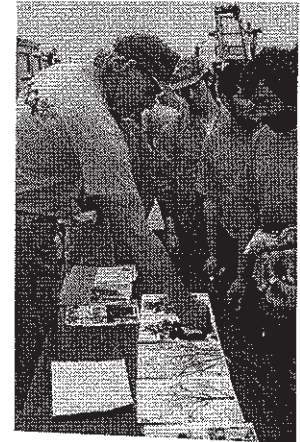

SAFETY PROGRAM



Safety standards are top priority at West Coast Arborists, Inc. Our line of work demands that all work is performed in a manner that provides the maximum safety to the general public as well as our employees. Our crews are instructed to follow the safety standards of ANSI Z133.1 as well as Cal-OSHA requirements. We have one of the most extensive safety training programs in the industry. We provide our employees with state-of-the-art training tools and instructional sessions company wide. Our insurance carriers and Cal-OSHA have recognized us repeatedly for outstanding safety training efforts. We have a full time Safety Trainer that is

professionally trained in the field of horticulture. He brings several years experience to the company as well as expertise in training new and existing employees. He administers I.S.A. certification training, in-house crew leader training programs, and new hire orientation training.

C. GREENWASTE RECYCLING

RECYCLING PROGRAM

WCA's commitment to be a socially responsible corporate partner to our customers and communities is exemplified in our Recycling Program. With the steadily-increasing concern for the ecological health of our communities, West Coast Arborists, Inc. has embarked on a landfill diversion process where all material is taken to recycling facilities where it is used in the production of soil amendments. We are committed to taking all recyclable materials removed from the trees trimmed for the duration of this project to a recycling center for processing. Verification of amounts recycled will be obtained and reported by West Coast Arborists, Inc. via ArborAccess for the purpose of meeting the goals of the State for reducing landfill usage.



RECYCLED PRODUCTS:

M U L C H

Mulch is made from coarse ground branches and leaves. It should be spread on the ground at a rate of six to twelve inches for best effect. Fresh mulch will deplete nitrogen from the surface of the soil which will reduce unwanted weeds. Once the mulch has decayed, it returns nitrogen which helps build the quality of soil for plants. A large amount of tree debris is processed by

West Coast Arborists and used in large scale mulching projects for establishing native plants in open space areas.



C O M P O S T

Compost is made from fine ground branches, leaves or other organic material. When mixed with oxygen and water, the organic material will decay or "compost." A finished compost is excellent for turning into the top layer of soil and will add nitrogen and increase the water holding capacity of soil. You can make compost at home in a pile in your yard or in a bin that you make or purchase. Large scale composting is done at regional recycling facilities.

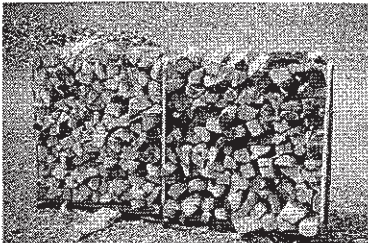

F I R E W O O D

Firewood is traditionally the most common use of large branches and logs. Firewood is used to heat homes during winter months. West Coast Arborists takes logs to a yard in Irvine where a firewood retailer splits and resells the fire-

wood to local residents.

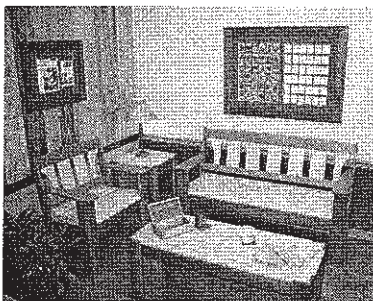

L O G S T O L U M B E R

Currently West Coast Arborists is looking for new and better ideas for the use of tree logs. An old idea with a new approach is converting city trees into usable lumber. WCA worked on a twelve month trial program with the California Department of Forestry and Fire Protection to create an environmentally sound and socially responsible alternative to importing lumber from other areas, reducing our demand on trees from natural forests. WCA has demonstrated its

ASSEMBLY BILL 939 (AB939)

The management of solid waste has become a major issue in California and throughout the country. Not only are we producing an increasing amount of solid waste each year, but we are running out of places to put it. Because of the concern about water and air pollution associated with landfills, the opportunities to develop additional disposal capacity are limited.

To address these issues, the Governor of California signed into law on September 29, 1989, Assembly Bill 939 (AB 939). The law fundamentally restructured the state's approach to solid waste management. AB 939 established an integrated waste management hierarchy in the following order of importance:

- Source reduction
- Recycling and composting
- Environmentally safe transformation and land disposal of solid wastes

AB 939 requires that each California county and incorporated city prepare a Source Reduction and Recycling Elements (SRRE) report which shows how they will meet solid waste diversion goals of 50 percent by the year 2000 and beyond.

West Coast Arborists, Inc., offers a multitude of waste diversion opportunities to cities including mulch, compost, firewood and logs to lumber. In an effort to provide cities with valued information pursuant to AB 939 requirements, we provide immediate reporting capabilities through ArborAccess at no additional cost.

SAMPLE RECYCLING REPORT

CITY OF TUSTIN				Green Waste Recycling Report	
From 1/1/06 to 1/31/06				By Individual Customer - All Job #	
Date	Job #	Truck	Recycling Site	Material	Weight
01/03/06	8499	R17	TIERRA VERDE RECYCLING	BRUSH	8.33
01/04/06	8498	D40	CVT RECYCLING	PALM	6.21
01/04/06	8499	R09	TIERRA VERDE RECYCLING	BRUSH	13.73
01/06/06	8499	D40	TIERRA VERDE RECYCLING	CHIP	4.86
01/10/06	8497	D40	TIERRA VERDE RECYCLING	PALM	4.54
01/11/06	8497	D40	TIERRA VERDE RECYCLING	CHIP	5.17
01/12/06	8499	D40	CVT RECYCLING	CHIP	5.92
01/12/06	8499	D40	TIERRA VERDE RECYCLING	CHIP	6.85
01/12/06	8499	D40	TIERRA VERDE RECYCLING	CHIP	6.80
01/13/06	8499	D40	TIERRA VERDE RECYCLING	CHIP	7.43
01/16/06	8497	D40	TIERRA VERDE RECYCLING	CHIP	3.53
01/17/06	8791	R17	TIERRA VERDE RECYCLING	BRUSH	5.20
01/17/06	8497	D40	CVT RECYCLING	CHIP	5.49
01/18/06	8497	D40	TIERRA VERDE RECYCLING	CHIP	5.79
01/19/06	8497	D40	TIERRA VERDE RECYCLING	CHIP	6.51
01/19/06	8499	R09	CVT RECYCLING	PALM	10.61
01/19/06	8499	R09	TIERRA VERDE RECYCLING	BRUSH	7.12
01/20/06	8497	D40	TIERRA VERDE RECYCLING	CHIP	5.73
01/24/06	8497	D62	CVT RECYCLING	CHIP	5.00
01/24/06	8497	D40	TIERRA VERDE RECYCLING	CHIP	6.09
01/25/06	8497	D62	TIERRA VERDE RECYCLING	CHIP	7.44
01/26/06	8497	D62	CVT RECYCLING	CHIP	6.25
01/27/06	8497	D40	TIERRA VERDE RECYCLING	PALM	5.98
TOTAL					150.58

VII. CERTIFICATION OF NON-DISCRIMINATION

Pursuant to California Labor Code Section 1735, as added by Chapter 643 statutes of 2039, and as amended,

No discrimination shall be made in the employment of persons upon Public Works because of race, religion creed, color, national origin, ancestry, physical handicaps, mental condition, marital status or sex of such persons, except as provided in Section 12940, of the California Labor Code and every Contractor of Public Works violating this section is subject to all penalties imposed for a violation of the Chapter.

I certify that I have read, and understand the foregoing:

SIGNATURE _____

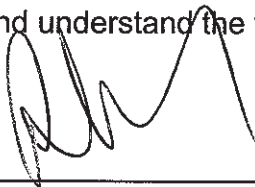

PRINTED NAME Patrick Mahoney

TITLE President

COMPANY NAME West Coast Arborists, Inc.

DATE 10/15/11

VIII. PROPOSAL AFFIRMATION

With regard to the information provided hereinabove (Exhibit E: Proposal Submittal Documents), I affirm that:

- All information provided is true and correct to the best of my knowledge, and;
- I understand that a materially false statement willfully or fraudulently made in connection with this proposal may result in the termination of any Contract between the Moreno Valley Community Services District and West Coast Arborists, Inc., and further, the aforesaid company may be barred from participation in future District contracts and be subject to possible criminal prosecution, and;
- I have legal authority to bind West Coast Arborists, Inc. to the terms of this affirmation (See "INSTRUCTION TO PROPOSER", Section D. – Signature of Contract Proposal).

FOR PROPOSAL TO BE VALID, THIS SHEET MUST BE FILLED OUT (PRINTED), SIGNED AND DATED

SIGNATURE _____

PRINTED NAME Patrick Mahoney

TITLE President

COMPANY NAME West Coast Arborists, Inc.

DATE 10/15/11

SCHEDULE II

R.F.P. NO. 2011 TREE TRIM/REMOVAL
PROJECT NO. 2011 TREE TRIM/REMOVAL

PARKWAY AND MEDIAN
TREE TRIMMING AND REMOVAL

I. BID SCHEDULE

PROPOSER: West Coast Arborists, Inc.

(Company Name)

<u>ZONE</u>	<u>NO. OF TRIMS</u>	<u>COST PER TRIM</u>	<u>NO. OF REMOVALS</u>	<u>COST PER REMOVAL</u>	<u>TOTAL COST TRIM/REMOVAL</u>
E-1	124	35.00	1	175.00	4,515.00
E-1A	25	75.00	0	350.00	1,875.00
E-2	188	35.00	18	175.00	9,730.00
E-3	393	35.00	23	175.00	17,780.00
E-4	204	35.00	81	175.00	21,315.00
E-7	75	35.00	0	350.00	2,625.00
E-8	36	75.00	0	700.00	2,700.00
E-12	0	125.00	0	1500.00	0.00
E-14	39	75.00	0	350.00	2,925.00
E-15	50	35.00	0	700.00	1,750.00
E-16	35	75.00	5	175.00	3,500.00
DSG-1	96	35.00	18	175.00	6,510.00
DSG-2N	184	35.00	16	175.00	9,240.00
DSG-2S	198	35.00	3	175.00	7,455.00
S	0	225.00	0	1500.00	0.00
M	15	75.00	1	175.00	1,300.00
TOTALS	1,662	64,170.00	216 166	29,050.00	93,220.00

The Total Amount of the Proposal In:

Figures: \$93,220 and 00 /100's Dollars

Words: Ninety Three Thousand, Two Hundred Twenty and 00 /100's Dollars

The Contractor shall furnish all labor, equipment, and materials necessary to provide parkway and median tree trimming/removal services as set forth in Exhibit A: Scope of Work of this Contract, and; any and all addenda issued prior to the opening of Proposals; any Change Orders issued after the execution of the Independent Contractor Agreement and its attached exhibits.

Addendum No(s) 1 & 2  has/have been received and is/are made a part of this proposal.

(AUTHORIZED SIGNATURE AND TITLE) 10/15/11
(DATE)

II. ADDITIONAL WORK PRICE LIST

THE FOLLOWING PRICES ARE HEREBY MADE A PART OF THIS AGREEMENT

Prices for Additional Work, include:

UNIT PRICES (Includes all labor and materials)

- | | | | | |
|----|-------------------------------------|---|--------------------|-------------------|
| 1. | Tree Trimming (per Service Request) | | | |
| | a. 0" – 6" dbh | @ | \$ <u>35.00</u> | ea |
| | b. 7" – 15" dbh | @ | \$ <u>75.00</u> | ea |
| | c. 16" – 23" dbh | @ | \$ <u>125.00</u> | ea |
| | d. 24" & larger dbh | @ | \$ <u>225.00</u> | ea |
| 2. | Tree & Stump Removal | @ | \$ <u>20.00</u> | ea |
| | | | Per inch dbh | |
| 3. | Stump Removal Only | @ | \$ <u>7.00</u> | ea |
| | | | Per inch dbh | |
| 4. | 3 man crew with equipment | @ | \$ <u>180.00</u> | per hr. |
| 5. | 3 man crew with equipment | @ | \$ <u>1,440.00</u> | per 8 hr. day |
| 6. | Emergency Response | @ | \$ 80.00 | per man/ per hour |
| 7. | Specialty Equipment w/ Operator | @ | \$ 120.00 | per hour |
| | -Crane & 95' Aerial Tower | | | |

PROPOSER: West Coast Arborists, Inc.

(Company Name)

III. CONTRACT PROPOSAL

The undersigned declares that he/she has carefully examined the location(s) of the proposed work, that he/she has examined the Specifications and has read the accompanying Instructions to Proposers, and hereby proposes and agrees, if this proposal is accepted, to enter into a Contract with the District for the good and faithful performance thereof, to furnish all material and do all work required to complete the said work in accordance with the Specifications, in the time and manner therein prescribed, for the unit cost and lump sum amounts set forth in the proposal and as listed as follows. The undersigned further declares that the representations made herein are made under penalty of perjury.

TOTAL BASE COMPENSATION AMOUNT (FROM Exhibit E, Section 1 (Schedule II) A. "Bid Schedule"):

Ninety Three Thousand, Two Hundred Twenty

(Dollar Amount in Words)

\$ \$93,220.00

(Dollar Amount in Figures)

Date: 10/15/11

Proposer: West Coast Arborists, Inc.

(Company Name)

By:

(Signature)

Title: President

State License Number and Classification: 366764 C27/C61/D49

If a corporation, complete the following:

INCORPORATED UNDER LAWS OF THE STATE OF California

PRESIDENT Patrick Mahoney

(Corporate Seal)

SECRETARY Richard Mahoney

IV. AFFIRMATION OF PROPOSAL GUARANTEE

The undersigned also affirms that:

Accompanying this proposal is a cashier's check, or a certified check, or a Proposal Surety Bond for 10% the amount of bid _____, payable to the Moreno Valley Community Services District, which is deemed to constitute liquidated damages, if, in the event this proposal is accepted, the undersigned shall fail to execute the Contract and furnish satisfactory bonds under the conditions and within the time specified in this proposal, otherwise said cashier's check, certified check or Proposal Surety Bond is to be returned to the undersigned.

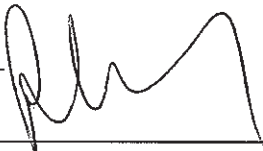
Dated 10/13/2011
Signature of Proposer _____ 

By Patrick Mahoney

Address of Proposer 2200 E. Via Burton St.
Anaheim, CA 92806

Telephone Number of Proposer (714) 991-1900

Names and Addresses of Members of the Company:
Patrick Mahoney, President- 191 Cobblestone Ln., Anaheim, CA 92806
Richard Mahoney, Secretary- 565 Peralta Hills Dr., Anaheim, CA 92807
Rose Epperson, Treasurer-32622B Success Valley Dr., Porterville, CA 93257

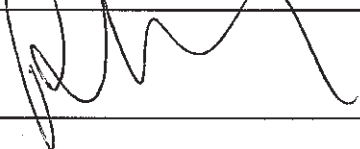
(If a Corporation)
Signature of Proposer _____ 

By Patrick Mahoney

Title President

Business Address 2200 E. Via Burton St.
Anaheim, CA 92806

Affirmation of Proposal Guarantee (cont.)

Incorporated Under Laws of the State of

California

State License Number and Classification

366764 C27/C61/D49

PRESIDENT

Patrick Mahoney

SECRETARY

Richard Mahoney

TREASURER

Rose Epperson

(Corporate Seal)

Proposal Surety Bond (cont.)

PRINCIPAL

Name: WEST COAST ARBORISTS, INC.

Address: 2200 E. VIA BURTON STREET

ANAHEIM, CA 92806

Tel. No.: 714/991-1900

By: PATRICK MAHONEY, PRESIDENT

CORPORATE SURETY

Name: CONTRACTORS BONDING AND INSURANCE COMPANY

Address: 111 PACIFICA SUITE 350

IRVINE, CA 92618

Tel. No.: (949) 341-9110

By: 
Attorney-in-Fact
MICHAEL D. STONG

SIGNING INSTRUCTIONS

- The Bond shall be executed by an admitted Surety insurer (CCP 995.311) and the Surety must be registered as an admitted insurer in at least one county in the State of California.
- The Bond shall include attached Notary Certificates for the Attorney-in-Fact and the Principal.
- The Bond shall include an attached original Power of Attorney only authorizing the Attorney-in-Fact to act for the Surety (CCP 1305).
- The Bond shall include the address at which the Principal and Surety may be served with notices, papers and other documents (CCP 995.320 (a)(2)).

If any of the above items are omitted, the proposal will be considered non-responsive and will be rejected.

CALIFORNIA ALL-PURPOSE CERTIFICATE OF ACKNOWLEDGMENT

State of California

County of RIVERSIDE

On 10/13/11 before me, R. NAPPI "NOTARY PUBLIC"
(Here insert name and title of the officer)

personally appeared MICHAEL D. STONG

who proved to me on the basis of satisfactory evidence to be the person(s) whose name(s) is/are subscribed to the within instrument and acknowledged to me that he/she/they executed the same in his/her/their authorized capacity(ies), and that by his/her/their signature(s) on the instrument the person(s), or the entity upon behalf of which the person(s) acted, executed the instrument.

I certify under PENALTY OF PERJURY under the laws of the State of California that the foregoing paragraph is true and correct.

WITNESS my hand and official seal.

R. Nappi
 Signature of Notary Public

(Notary Seal)

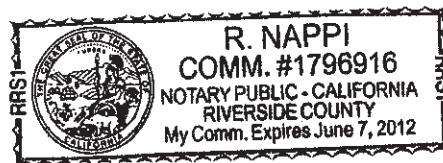

ADDITIONAL OPTIONAL INFORMATION

DESCRIPTION OF THE ATTACHED DOCUMENT

(Title or description of attached document)

(Title or description of attached document continued)

Number of Pages _____ Document Date _____

(Additional information)

CAPACITY CLAIMED BY THE SIGNER

Individual (s)

Corporate Officer

(Title)

Partner(s)

Attorney-in-Fact

Trustee(s)

Other _____

INSTRUCTIONS FOR COMPLETING THIS FORM

Any acknowledgment completed in California must contain verbiage exactly as appears above in the notary section or a separate acknowledgment form must be properly completed and attached to that document. The only exception is if a document is to be recorded outside of California. In such instances, any alternative acknowledgment verbiage as may be printed on such a document so long as the verbiage does not require the notary to do something that is illegal for a notary in California (i.e. certifying the authorized capacity of the signer). Please check the document carefully for proper notarial wording and attach this form if required.

- State and County information must be the State and County where the document signer(s) personally appeared before the notary public for acknowledgment.
- Date of notarization must be the date that the signer(s) personally appeared which must also be the same date the acknowledgment is completed.
- The notary public must print his or her name as it appears within his or her commission followed by a comma and then your title (notary public).
- Print the name(s) of document signer(s) who personally appear at the time of notarization.
- Indicate the correct singular or plural forms by crossing off incorrect forms (i.e. ~~he/she/they~~, is/are) or circling the correct forms. Failure to correctly indicate this information may lead to rejection of document recording.
- The notary seal impression must be clear and photographically reproducible. Impression must not cover text or lines. If seal impression smudges, re-seal if a sufficient area permits, otherwise complete a different acknowledgment form.
- Signature of the notary public must match the signature on file with the office of the county clerk.
 - ❖ Additional information is not required but could help to ensure this acknowledgment is not misused or attached to a different document.
 - ❖ Indicate title or type of attached document, number of pages and date.
 - ❖ Indicate the capacity claimed by the signer. If the claimed capacity is a corporate officer, indicate the title (i.e. CEO, CFO, Secretary).
- Securely attach this document to the signed document



Contractors Bonding and Insurance Company
 1213 Valley Street
 P.O. Box 9271
 Seattle, WA 98109-0271

POWER OF ATTORNEY

Contractors Bonding and Insurance Company

Know All Men by These Presents:

That this Power of Attorney is not valid or in effect unless attached to the bond which it authorizes executed, but may be detached by the approving officer if desired.

That **Contractors Bonding and Insurance Company**, a Washington corporation, does hereby make, constitute and appoint: Jeremy Pendergast, Rosemary Nappi, Michael D. Stong, jointly or severally.

in the City of Riverside, State of California its true and lawful Agent and Attorney in Fact, with full power and authority hereby conferred, to sign, execute, acknowledge and deliver for and on its behalf as Surety, the following described bond.

Any and all bonds, undertakings, and recognizances in an amount not to exceed Ten Million and 00/100 Dollars (\$10,000,000.00) for any single obligation.

The acknowledgment and execution of such bond by the said Attorney in Fact shall be as binding upon this Company as if such bond had been executed and acknowledged by the regularly elected officers of this Company.

The **Contractors Bonding and Insurance Company** further certifies that the following is a true and exact copy of the Resolution adopted by the Board of Directors of **Contractors Bonding and Insurance Company**, and now in force to-wit:

"All bonds, policies, undertakings, Powers of Attorney or other obligations of the Corporation shall be executed in the corporate name of the Corporation by the President, Secretary, any Assistant Secretary, Treasurer, or any Vice President, or by such other officers as the Board of Directors may authorize. The President, any Vice President, Secretary, any Assistant Secretary, or the Treasurer may appoint Attorneys in Fact or Agents who shall have authority to issue bonds, policies or undertakings in the name of the Corporation. The corporate seal is not necessary for the validity of any bonds, policies, undertakings, Powers of Attorney or other obligations of the Corporation. The signature of any such officer and the corporate seal may be printed by facsimile or other electronic image."

IN WITNESS WHEREOF, the **Contractors Bonding and Insurance Company** has caused these presents to be executed by its Vice President with its corporate seal affixed this 11th day of July, 2011.



Contractors Bonding and Insurance Company

Roy C. Die Vice President

State of Washington }
 County of King } SS

On this 11th day of July, 2011, before me, a Notary Public, personally appeared Roy C. Die, who being by me duly sworn, acknowledged that he signed the above Power of Attorney as the aforesaid officer of the **Contractors Bonding and Insurance Company** and acknowledged said instrument to be the voluntary act and deed of said corporation.

Joseph B. Muller
 Joseph B. Muller Notary Public

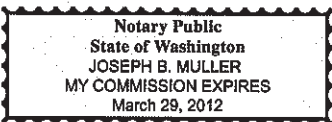

CERTIFICATE

I, the undersigned officer of **Contractors Bonding and Insurance Company**, a stock corporation of the State of Washington, do hereby certify that the attached Power of Attorney is in full force and effect and is irrevocable; and furthermore, that the Resolution of the Company as set forth in the Power of Attorney, is now in force. In testimony whereof, I have hereunto set my hand and the seal of the **Contractors Bonding and Insurance Company** this 13th day of October, 2011.

Contractors Bonding and Insurance Company

Roy C. Die Vice President

0475572032912

A0059511

VI. NON-COLLUSION AFFIDAVIT

STATE OF CALIFORNIA)
COUNTY OF Orange)§

(NAME) Patrick Mahoney, affiant
being first duly sworn, deposes and says:

That he or she is President of
(sole owner, partner or other proper title)

West Coast Arborists, Inc. the party making the
(Contractor)

foregoing bid, that the bid is not made in the interest of, or on behalf of, any undisclosed person, partnership, company, association, organization, or corporation; that the bid is genuine and not collusive or sham; that the bidder has not directly or indirectly induced or solicited any other bidder to put in a false or sham bid, and has not directly or indirectly colluded, conspired, connived, or agreed with any bidder or anyone else to put in a sham bid, or that anyone shall refrain from bidding; that the bidder has not in any manner, directly or indirectly, sought by agreement, communication, or conference with anyone to fix the bid price of the bidder or any other bidder, or to fix any overhead, profit, or cost element of the bid price, or of that of any other bidder, or to secure any advantage against the public body awarding the contract of anyone interested in the proposed contract; that all statements contained in the bid are true; and, further, that the bidder has not, directly or indirectly, submitted his or her bid price or any breakdown thereof, or the contents thereof, or divulged information or data relative thereto, or paid, and will not pay, any fee to any corporation, partnership, company association, organization, bid depository, or to any member or agent thereof to effectuate a collusive or sham bid (Public Contract Code Section 7106).

Bidder's Name: West Coast Arborists, Inc.

Bidder's Address: 2200 E. Via Burton St.

Anaheim, CA 92806

Telephone No.: (714) 991-1900

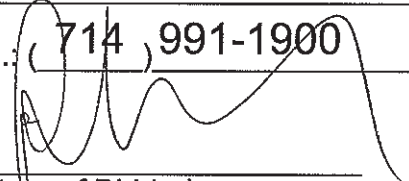
(Signature of Bidder)

President
(Title) 

ALL SIGNATURES MUST BE NOTARIZED

APPENDIX A: PREVAILING WAGE DETERMINATION

GENERAL PREVAILING WAGE DETERMINATION MADE BY THE DIRECTOR OF INDUSTRIAL RELATIONS
PURSUANT TO CALIFORNIA LABOR CODE PART 7, CHAPTER 1, ARTICLE 2, SECTIONS 1770, 1773 AND 1773.1

CRAFT: ## LANDSCAPE MAINTENANCE LABORER

DETERMINATION: SC-LML-2008-1

ISSUE DATE: February 22, 2008

EXPIRATION DATE OF DETERMINATION: December 31, 2008* Effective until superseded by a new determination issued by the Director of Industrial Relations. Contact the Division of Labor Statistics and Research at (415) 703-4774 for the new rates after 10 days from the expiration date, if no subsequent determination is issued.

LOCALITY:	Employer Payments						Straight-Time Hours	Total Hourly Rate	Overtime 1 1/2X Rate
	Basic Hourly Rate	Health and Welfare	Pension	Vacation	Holiday	Training			
Imperial	\$8.00	-	-	^a 0.115	0.17	-	8	^b 8.285	^b 12.285
Inyo, Mono and San Bernardino	8.00	-	-	0.30	0.17	-	8	8.47	12.47
Kern	8.00	-	-	^a 0.16	0.17	-	8	^b 8.33	^b 12.33
Los Angeles	10.00	-	-	^d 0.27	0.46	-	8	^b 10.73	^b 15.73
Orange	8.00	0.89	-	^a 0.115	0.14	-	8	^b 9.145	^b 13.145
Riverside	8.00	-	-	^f 0.11	0.11	-	8	^b 8.22	^b 12.22
San Diego	8.00	-	-	^e 0.20	0.16	-	8	^b 8.36	^b 12.36
San Luis Obispo	8.00	-	-	0.22	0.115	-	8	8.335	12.335
San Luis Obispo	8.00	-	-	0.24	0.12	-	8	8.36	12.36
San Luis Obispo	8.00	-	-	^g 0.15	0.15	-	8	8.30	12.30
San Luis Obispo	8.00	-	-	^h 0.16	0.16	-	8	8.32	12.32
Santa Barbara	8.00	-	-	^h 0.12	0.12	-	8	^b 8.24	^b 12.24
San Luis Obispo	8.00	-	-	ⁱ 0.13	0.13	-	8	^b 8.26	^b 12.26
Ventura	8.00	-	-	0.115	0.16	-	8	8.275	12.275
Ventura	8.00	2.97	-	^j 0.19	0.26	-	8	^b 11.42	^b 15.42

Craft is not apprenticeable.

NOTE: If there are two rates, the first rate is for routine work, the second rate is for complex work.

^{*}\$0.22 after 3 years of service.

^f\$0.22 after 4 years of service.

^bComputation is based on the first years of employment. This rate should be increased by any applicable vacation increase as stated in other footnotes.

^g\$0.40 after 3 years of service.

^h\$0.23 after 2 years of service.

^c\$0.31 after 2 years of service.

ⁱ\$0.27 after 2 years of service.

^j\$0.38 after 3 years of service.

^d\$0.54 after 2 years of service; \$0.81 after 3 years of service.

^k\$0.29 after 2 years of service.

^e\$0.24 after 3 years of service; \$0.37 after 7 years of service.

^l\$0.31 after 2 years of service.

RECOGNIZED HOLIDAYS: Holidays upon which the general prevailing hourly wage rate for Holiday work shall be paid, shall be all holidays in the collective bargaining agreement, applicable to the particular craft, classification, or type of worker employed on the project, which is on file with the Director of Industrial Relations. If the prevailing rate is not based on a collectively bargained rate, the holidays upon which the prevailing rate shall be paid shall be as provided in Section 6700 of the Government Code. You may obtain the holiday provisions for the current determinations on the Internet at <http://www.dir.ca.gov/DLSR/PWD>. Holiday provisions for current or superseded determinations may be obtained by contacting the Prevailing Wage Unit at (415) 703-4774.

TRAVEL AND/OR SUBSISTENCE PAYMENT: In accordance with Labor Code Sections 1773.1 and 1773.9, contractors shall make travel and/or subsistence payments to each worker to execute the work. You may obtain the travel and subsistence provisions for the current determinations on the Internet at <http://www.dir.ca.gov/DLSR/PWD>. Travel and subsistence provisions for current or superseded determinations may be obtained by contacting the Prevailing Wage Unit at (415) 703-4774.

APPENDIX B: MONTHLY REPORT FORM

MONTHLY REPORT
 MORENO VALLEY COMMUNITY SERVICES DISTRICT MONTH OF

PROJECT NO. _____
 _____, 20____

LOCATION OF TREES TRIMMED/REMOVED	NUMBER OF TREES TRIMMED/REMOVED	COMPLAINTS • DATE(S) RECEIVED • COMPLAINT/ACTION • DATE CORRECTED	HAZARDS • DATE(S) NOTED • HAZARD TYPE • MVCSD NOTIFIED • DATE CORRECTED
WEEK 1			
WEEK 2			
WEEK 3			
WEEK 4			
WEEK 5			

APPENDIX C: GREENWASTE REPORT FORM
MORENO VALLEY COMMUNITY SERVICES DISTRICT
-MONTHLY GREENWASTE REPORT-
FOR

MONTH: _____ YEAR: _____

1. Source of greenwaste (Project No./Location): _____

2. Amount of greenwaste generated from above source (by weight): _____ LBS. -or- TONS.

3. Name, address, and phone number of recycle accepting greenwaste:

- Company Name: _____

- Address: _____

- Phone Number: (_____) _____

4. Amount of greenwaste-source products (mulch, compost, top dressing, and soil amendments, etc.) furnished to Project (by weight): _____ LBS. -or- TONS.

5. Name, address, and phone number of recycle supplying greenwaste-source products to Project (if different from No. 3 above):

CONTRACTOR: _____

ADDRESS: _____

PHONE: (_____) _____

This page intentionally left blank.

**MINUTES - REGULAR MEETING OF JULY 9, 2013 (Report
of: City Clerk Department)**

Recommendation: Approve as submitted.

SEE AGENDA ITEM A.2

This page intentionally left blank.

**MINUTES - REGULAR MEETING OF JULY 9, 2013 (Report
of: City Clerk Department)**

Recommendation: Approve as submitted.

SEE AGENDA ITEM A.2

This page intentionally left blank.

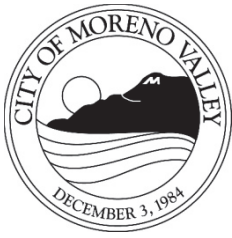

APPROVALS	
BUDGET OFFICER	<i>me</i>
CITY ATTORNEY	<i>SMB</i>
CITY MANAGER	<i>d</i>

Report to City Council

TO: Mayor and City Council

FROM: Richard Teichert, Chief Financial Officer

AGENDA DATE: August 27, 2013

TITLE: PUBLIC MEETING REGARDING THE MAIL BALLOT PROCEEDING FOR APN 291-650-011 BALLOTING FOR NPDES

RECOMMENDED ACTION

Recommendations: That the City Council:

1. Accept public comments regarding the mail ballot proceeding for Assessor Parcel Number (APN) 291-650-011 for approval of the National Pollutant Discharge Elimination System (NPDES) maximum commercial/industrial regulatory rate.

ADVISORY BOARD/COMMISSION RECOMMENDATION

N/A

BACKGROUND

To comply with the 1972 Federal Clean Water Act, Land Development, a division of the Public Works Department, requires that new development projects participate in the appropriate NPDES regulatory rate to fund federally mandated programs. The City Council adopted the residential regulatory rate on June 10, 2003, and the commercial/industrial regulatory rate on January 10, 2006.

Conditions of Approval for APN 291-650-011 require that the property owner provide a funding source to help support the Stormwater Management program. Approving the NPDES maximum commercial/industrial regulatory rate through a mail ballot proceeding fulfills this requirement.

DISCUSSION

In compliance with Proposition 218, which requires that any new or proposed increase in property-related assessments, fees, or charges be submitted to property owners for approval, a mail ballot proceeding is being conducted to give the property owner of APN 291-650-011 the option to approve or oppose the collection of the NPDES maximum commercial/industrial regulatory rate on the property tax bill or as a monthly charge on a utility bill. Property owners are given two opportunities to address the legislative body regarding the charge(s) they are being balloted on. These two opportunities are the Public Meeting on August 27, 2013 and the Public Hearing on September 10, 2013, when the results of the ballot proceeding will be announced.

Public agencies are to obtain Permits to discharge urban stormwater runoff from municipally owned drainage facilities, including streets, highways, storm drains, and flood control channels. New development projects are subject to the current NPDES Permit requirements for stormwater management as mandated by the Federal Clean Water Act. If approved by the property owner, the City will annually inspect site design, source and treatment control Best Management Practices, monitor maintenance records for those on-site facilities, and perform annual inspections of the affected areas to ensure compliance with federally mandated NPDES Permit requirements, as administered by the State. Provided the mail ballot is approved, the City will also be authorized to levy the NPDES maximum commercial/industrial regulatory rate on the annual property tax bill or as a monthly charge on a utility bill.

ALTERNATIVES

1. **Accept public comments** regarding the mail ballot proceeding for APN 291-650-011 for approval of the NPDES Maximum Commercial/Industrial Regulatory Rate. *By accepting public comment, the City complies with Proposition 218 state statutes for providing public comment.*
2. **Do not accept public comments** regarding the mail ballot proceeding for APN 291-650-011 for approval of the NPDES Maximum Commercial/Industrial Regulatory Rate. *This alternative would be contrary to state statutes and would require the noticing period for the mail ballot proceeding to begin again.*

FISCAL IMPACT

For fiscal year (FY) 2013/14, the NPDES Maximum Commercial/Industrial Regulatory Rate is \$223 per parcel. Beginning FY 2014/15, the NPDES Maximum Commercial/Industrial Regulatory Rate shall be subject to an annual adjustment based on the percentage change calculated for the previous year in the Los Angeles-Riverside-Orange County Regional Consumer Price Index for All Urban Consumers, as published by the Department of Labor's Bureau of Labor Statistics.

The NPDES rates collected from property owners support the current Permit programs and reduce the level of General Fund support necessary to remain in

compliance with unfunded federal mandates, as administered by the State. Funds collected from the NPDES rates are restricted for use only within the Stormwater Management program.

CITY COUNCIL GOALS

Advocacy

Management of the stormwater will ensure that water pollutants are discharged in compliance with federal mandates and City policies.

Revenue Diversification and Preservation

The NPDES maximum commercial/industrial regulatory rate provides funding for program costs, which includes administration.

SUMMARY

The action before the City Council is to accept public comments regarding the mail ballot proceeding for APN 291-650-011.

NOTIFICATION

The property owner of APN 291-650-011 has been given a 45-day noticing period to review the ballot documents. The documents included a notice to the property owner, map of the project area, ballot, instructions for marking and returning the ballot, and a postage-paid envelope for returning the ballot to the City Clerk. (See Attachment 1.)

Newspaper advertising for the August 27, 2013, Public Meeting and September 10, 2013, Public Hearing was published in The Press-Enterprise on August 8, 2013. Additionally, the Public Hearing notification was published on August 22 and will be published again on August 29, 2013.

ATTACHMENTS

Attachment 1: Miguel's Jr mail ballot packet

Prepared by:
Jennifer Terry,
Management Analyst

Department Head Approval:
Richard Teichert
Chief Financial Officer

Concurred by:
Candace E. Cassel,
Special Districts Division Manager

Concurred by:
Mark W. Sambito, P.E.
Engineering Division Manager

Council Action	
Approved as requested:	Referred to:
Approved as amended:	For:
Denied:	Continued until:
Other:	Hearing set for:

TEL: 951.413.3480
 FAX: 951.413.3498
 WWW.MOVAL.ORG



14331 FREDERICK STREET, SUITE 2
 P. O. BOX 88005
 MORENO VALLEY, CA 92552-0805

SDG Investments LLC
 P.O. Box 1083
 Corona, CA 92878

July 3, 2013

NOTICE TO PROPERTY OWNER-MAIL BALLOT PROCEEDING FOR THE NATIONAL POLLUTANT DISCHARGE ELIMINATION SYSTEM (NPDES) MAXIMUM COMMERCIAL/INDUSTRIAL REGULATORY RATE FOR APN 291-650-011

******* OFFICIAL BALLOT ENCLOSED *******

Introduction

In November of 1996, California voters passed Proposition 218 ("The Right to Vote on Taxes Act"). As a result, any new or proposed increase in a property-related charge requires approval of the charge by the property owner of record. In compliance with Proposition 218 legislation, the City of Moreno Valley Special Districts Division is conducting a mail ballot proceeding to provide the owner of Assessor's Parcel Number (APN) 291-650-011 the opportunity to express support for or opposition to the approval of the NPDES Maximum Commercial/Industrial Regulatory Rate and services. Approval of the NPDES Maximum Commercial/Industrial Regulatory Rate through a mail ballot proceeding will fulfill the Conditions of Approval to provide a funding source for the NPDES program.

Background

The City shall provide the services necessary to meet mandates of the Federal Clean Water Act. The current NPDES Permit, as administered by the State, regulates the volume and amount of pollutants in stormwater runoff from all development types. NPDES Maximum Commercial/Industrial Regulatory Rate provides financial support for inspecting site design, source and treatment control Best Management Practices, monitoring maintenance records for those on-site facilities, and performing annual inspections of the affected areas to ensure compliance with federally mandated NPDES Permit requirements, as administered by the State.

Services Provided

In compliance with the Federal Clean Water Act, the City of Moreno Valley shall annually inspect site design, source and treatment control Best Management Practices, verify monitoring and maintenance records for those on-site facilities, and perform annual inspections of the affected areas to ensure compliance with federally mandated NPDES Permit requirements.

How is the Amount of the Charge Determined?

Each fiscal year (FY), the City of Moreno Valley shall determine the type of services necessary to comply with NPDES Permit requirements and levy the rate applicable for that service. The rate levied shall not exceed the rate previously approved by the property owner.

Proposed Charge

For FY 2013/14, the NPDES Maximum Commercial/Industrial Regulatory Rate is \$223 per parcel. The total amount of the NPDES rates levied for FY 2012/13 for the program as a whole was \$409,809.00.

Annual Adjustment

Beginning in FY 2014/15, the NPDES Maximum Commercial/Industrial Regulatory Rate shall be subject to an annual adjustment based on the percentage change calculated for the previous year in the Los Angeles-Riverside-Orange County Regional Consumer Price Index for All Urban Consumers, as published by the Department of Labor's Bureau of Labor Statistics.

Duration of the Charge

Upon approval of the NPDES Maximum Commercial/Industrial Regulatory Rate, the annual levy amount will be assessed to APN 291-650-011 (and any division thereof) and shall be placed on the Riverside County property tax bill or as a monthly charge on a utility bill. The NPDES Maximum Commercial/Industrial Regulatory Rate will be levied each following year at the proposed rate, which may include an annual inflation adjustment.

Public Hearing

To provide information concerning this mail ballot proceeding the City has scheduled one (1) Public Meeting and one (1) Public Hearing, which will be held at the **Moreno Valley City Hall Council Chamber located at 14177 Frederick Street, Moreno Valley.**

<u>Public Meeting</u>	<u>Public Hearing</u>
Tuesday, August 27, 2013 6:00 P.M. (Or As Soon Thereafter As The Matter May Be Called)	Tuesday, September 10, 2013 6:00 P.M. (Or As Soon Thereafter As The Matter May Be Called)

Tabulation of returned ballots will commence after the close of the Public Hearing. All ballots received shall be tabulated under the direction of the City Clerk in compliance with the current Policy For Conducting Mail Ballot Proceedings Policy #1.12.

Effect if Approval of the Charges is Approved

Approval of the NPDES Maximum Commercial/Industrial Regulatory Rate will be confirmed if the ballot is marked in favor of the NPDES rate. Approving the NPDES Maximum Commercial/Industrial Regulatory Rate through a mail ballot proceeding will fulfill the Conditions of Approval to provide a funding source for the NPDES program.

Effect if Approval of the Charges is Not Approved

Not approving the NPDES Maximum Commercial/Industrial Regulatory Rate to meet federally mandated NPDES Permit requirements may result in noncompliance with the Conditions of Approval. If the returned valid ballot is marked opposing the NPDES rate, then the rate will not be levied on the property tax bill.

For More Information

If you have any questions about the proposed program, the annual rate, or about the mail ballot proceeding process, please contact Jennifer Terry, Management Analyst, Special Districts, a

Division of the Financial and Management Services Department, Monday through Thursday from 7:30 a.m. to 6:00 p.m. at 951.413.3505 or via email at JenniferT@moval.org.

Completing Your Ballot

The enclosed ballot shall be submitted to the City Clerk in support of or opposition to the proposed program and annual charge. Please follow the instructions listed below to complete and return your ballot. Procedures for the completion, return, and tabulation of the ballot are also on file in the City Clerk's office.

1. Mark the enclosed ballot in support of or opposition to the proposed program and annual rate **by placing a mark in the corresponding box.**
2. Sign your name on the ballot. Ballots received without signature(s) will be considered invalid *and will not be counted.*
3. Mail or personally deliver your completed ballot in a sealed envelope to the City Clerk's office, 14177 Frederick Street, Moreno Valley, California, 92553. For your convenience, a postage-paid envelope has been included for return of the ballot.
4. Ballot(s) must be **received** by the City Clerk prior to the close of the Public Hearing to be held on **Tuesday, September 10, 2013**, at the Moreno Valley City Hall Council Chamber. The Public Hearing will be held at 6:00 p.m. or as soon thereafter as the matter may be called. Ballots received after the close of the Public Hearing cannot be legally counted.

Ballot Marks

Appropriate ballot markings include any one of the following for either the YES/Approved or NO/Not Approved blank box:



A check mark substantially inside a box;



An X mark substantially inside a box;



A dot or oval mark substantially inside a box;



A completely shaded or filled mark substantially inside a box;



A line, single or dashed, or combination of lines, through the box area. Lines may be any one of the following marks: horizontal, vertical, or diagonal. The mark may either run from side to side or corner to corner. All valid lines must be substantially within the box area and not marking any part of another blank box on the ballot;



A circle around the box and/or associated clause; or



A square or rectangle around the box and/or associated clause.

Balloting marks shall not extend past one box area into any portion of another nor surround the perimeter or any portion of more than one box area. Markings that extend past one box area into any portion of another or surround the perimeter or any portion of more than one box area shall be considered invalid and not counted.

Ballot Mark Revisions (Changes): An error or desire to revise (change) a selection made on the ballot may be completed and returned any time **prior** to the conclusion of public testimony at the Public Hearing. **The revision must be initialed by the record owner(s) of property. Initials must be clearly printed and placed at the right top corner of the revised selection.**

Miguel's Jr Restaurant PA12-0055

- Median
- - - Landscaped Areas
- APN
- 291650011
- ~ Roads
- ▭ Parcels
- ▭ City Boundary

Map reflects all changes indicated on Riverside County Assessor Maps as of July 1, 2013.

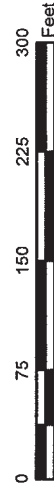

G:\V\PSDAMiguel's Jr PA12-0055.mxd

The information shown on this map was compiled from the Riverside County GIS and the City of Moreno Valley GIS. The land base and facility information on this map is for display purposes only and should not be relied upon without independent verification as to its accuracy. Data and information on this map is subject to update and modification. Riverside County and City of Moreno Valley will not be held responsible for any claims, losses or damages resulting from the use of this map. This map is not to be recycled or resold.

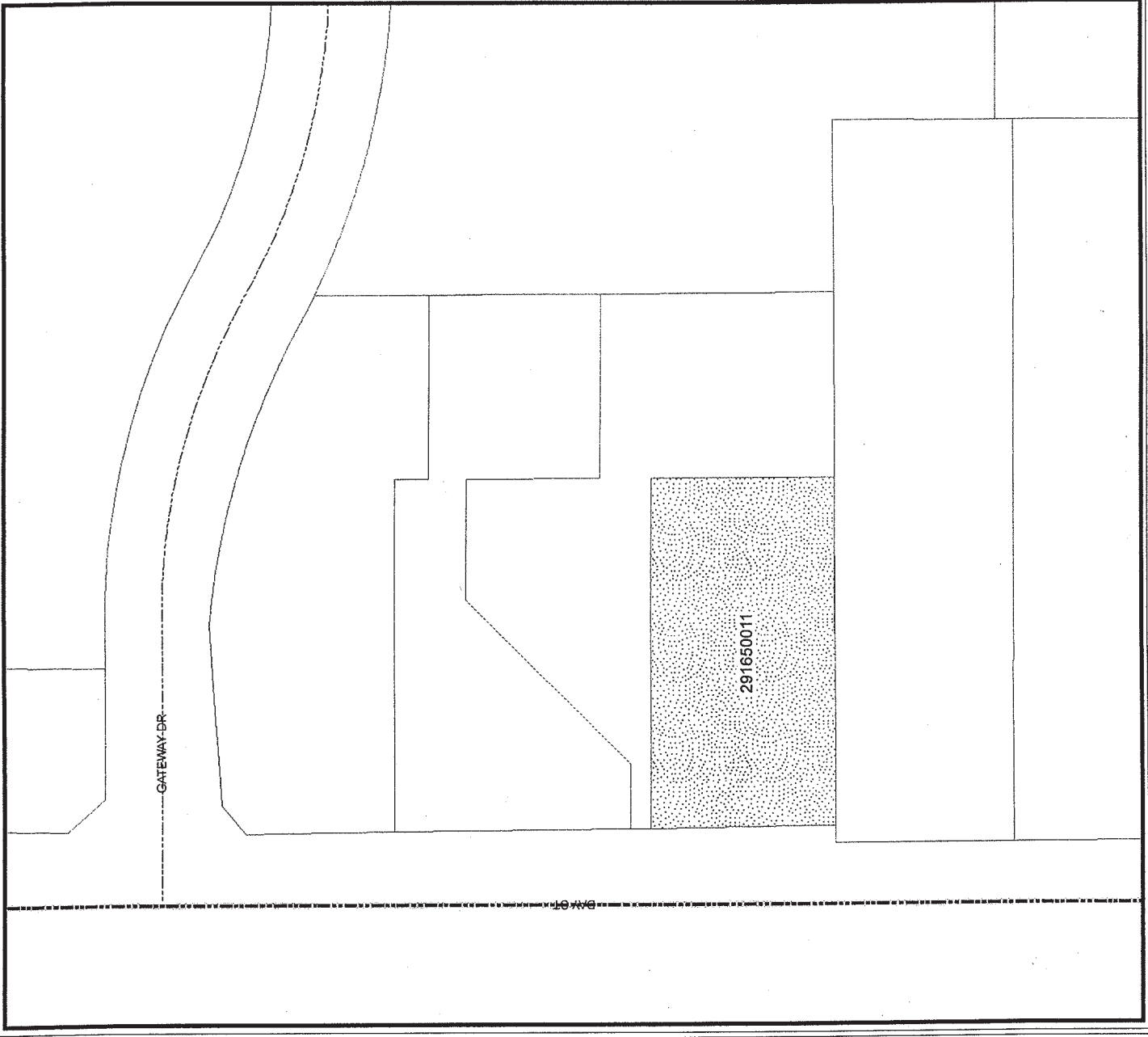

COMMON INTEREST, COMMERCIAL, INDUSTRIAL AND QUASI-PUBLIC USE NPDES RATE SCHEDULE
 Adopted by the City Council on January 10, 2006

LEVEL 1		LEVEL II	
NPDES Administration <i>(Not covered by CSA 152)</i>		Site Design, Source Control and Treatment Control BMPs Monitoring and Maintenance	
Costs associated with personnel, administration and management of the storm water management program. Administrative tasks include development and filing of various stormwater reports and data collection and management.	Level I is levied on all parcels conditioned for the NPDES Rate Schedule.	Costs associated with stormwater and non-stormwater runoff monitoring, inspection of the project's site design, source control and treatment control BMPs; evaluation of site stormwater compliance activities, review of site-specific technical reports and treatment control BMP maintenance records.	
Fiscal Year (FY) 2005/2006 - Base Year Calculation, subject to an annual inflation factor based on the Los Angeles-Riverside-Orange County Regional Consumer Price Index for All Urban Consumers, as published by the Department of Labor's Bureau of Labor Statistics		Per Month	Per Year
PROPOSED PARCEL RATE	\$2.67	\$32.00	
		PROPOSED PARCEL RATE	Per Month \$12.58
			Per Year \$151.00

Inflation Factor Adjustments

- FY 2006/2007 - 4.5% = (\$33.00 & \$158.00)
- FY 2007/2008 - 3.1% = (\$34.00 & \$163.00)
- FY 2008/2009 - 4.2% = (\$35.00 & \$170.00)
- FY 2009/2010 - no change = (\$35.00 & \$170.00)
- FY 2010/2011 - no change = (\$35.00 & \$170.00)
- FY 2011/2012 - 3.8% = (\$36.00 & \$176.00)
- FY 2012/2013 - 2.7% = (\$37.00 & \$181.00)
- FY 2013/2014 - 2.0% = (\$38.00 & \$185.00) rounded to the nearest dollar

**OFFICIAL MAIL BALLOT for
Assessor's Parcel Number (APN) 291-650-011**

**National Pollutant Discharge Elimination System (NPDES)
Maximum Commercial/Industrial Regulatory Rate**

YES* — as property owner of APN 291-650-011, I approve the NPDES Maximum Commercial/Industrial Regulatory Rate and services. For fiscal year (FY) 2013/14, the NPDES Maximum Commercial/Industrial Regulatory Rate is \$223 per parcel. Upon approval of the maximum regulatory rate, the annual levy amount shall be placed on the Riverside County property tax bill or as a monthly charge on a utility bill. Beginning FY 2014/15, the maximum regulatory rate shall be subject to an annual adjustment based on the percentage change calculated for the previous year in the Los Angeles-Riverside-Orange County Regional Consumer Price Index for All Urban Consumers, as published by the Department of Labor's Bureau of Labor Statistics. The City will annually inspect site design, source and treatment control Best Management Practices, verify monitoring and maintenance records for those on-site facilities, and perform annual inspections of the affected areas to ensure compliance with federally mandated NPDES Permit requirements, as administered by the State.

NO** — as property owner of APN 291-650-011, I do not approve the NPDES Maximum Commercial/Industrial Regulatory Rate and services. I understand that not approving the NPDES Maximum Commercial/Industrial Regulatory Rate to fund federally mandated NPDES Permit requirements shall result in noncompliance with the project's Conditions of Approval. The NPDES maximum commercial/industrial regulatory rate shall not be levied on the Riverside County property tax bill.

Assessor Parcel Number	YES*	NO**	NPDES Maximum Commercial/Industrial Regulatory Rate
291-650-011 (and any division thereof)	<input type="checkbox"/>	<input type="checkbox"/>	\$223

This ballot must be received by the City Clerk of the City of Moreno Valley prior to the close of the Public Hearing to be held on September 10, 2013, at the Moreno Valley City Hall Council Chamber, 14177 Frederick Street, Moreno Valley, California. The Public Hearing will be held at 6:00 p.m. or as soon thereafter as the matter may be called.

PROPERTY OWNER SIGNATURE DATE

Please remember to mark the appropriate box, sign and date the ballot and return to the City Clerk's office in the enclosed envelope prior to the close of the September 10, 2013 Public Hearing

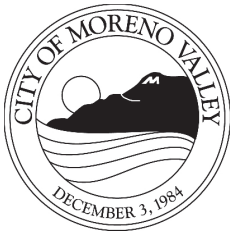

APPROVALS	
BUDGET OFFICER	<i>me</i>
CITY ATTORNEY	<i>SMB</i>
CITY MANAGER	<i>d</i>

Report to City Council

TO: Mayor and City Council

FROM: Thomas M. DeSantis, Assistant City Manager

AGENDA DATE: August 27, 2013

TITLE: MONTHLY REPORT: MORENO VALLEY ANIMAL SHELTER ADOPTION RATE

RECOMMENDED ACTION

Recommendations: That the City Council:

1. Receive and file the Monthly Report: Moreno Valley Animal Shelter Adoption Rate for the periods of May 1, 2013 to May 31, 2013 and June 1, 2013 to June 30, 2013.

BACKGROUND

The City Council has challenged staff to increase adoptions and decrease euthanasia rates at the Moreno Valley Animal Shelter. Ongoing evaluation of programs and services, along with increasing public awareness will remain key elements to our success in increasing adoptions of homeless pets from our Shelter.

DISCUSSION

As a follow up to the December 18, 2012 City Council Study Session on Animal Shelter operations, Mayor Owings asked that monthly staff reports be prepared to keep the public informed of the City's progress and the ongoing need to increase pet adoptions and other programs to reduce the number of homeless animals euthanized.

The May and June 2013 reports reveal a Placement (Returned to Owners, Transfer or Adoption) Rate of 41% and 38% respectively, which represents an increase over last year's Placement Rate by 11% for May and 8% for June. Other factors which are noteworthy include:

- The number of cats taken in at the Shelter during May and June 2013 continue to increase each month which is expected during the breeding season. The good news is the intake of cats has declined when compared to May and June 2012 by 5% and 7% respectively.
- The number of dogs taken in at the Shelter during May and June 2013 declined as compared to May and June 2012 by 14% and 28% respectively.
- The number of dog adoptions during May and June 2013 increased as compared to a year ago in May and June 2012 by 54% and 49% respectively.
- The number of cat adoptions remained unchanged in June 2013 as compared to June 2012. There was a decrease in the number of cat adoptions by 22% in May 2013 as compared to May 2012.
- The number of dogs euthanized decreased in May 2013 by 47% when compared to May 2012. Dogs euthanized in June 2013 also decreased by 35% compared to June 2012.
- The number of cats euthanized decreased in May 2013 by 16% compared to May 2012 although experienced a minor increase of 2% in June 2013 compared to June 2012.
- The 16 pets for which adoptive homes could not be found in May 2013 constituted just over 3% of all pets euthanized in our Shelter while in June 2013, the 24 pets not adopted accounted for 4% of all pets euthanized.

Staff wishes to thank the following Moreno Valley businesses who have sponsored and promoted the Moreno Valley Animal Shelter during the 2013 ASPCA Rachael Ray \$100 K Challenge:

- Bud's Tire & Wheel
- Costco Wholesale – Moreno Valley
- Estates Furniture
- Family Music Room
- Moreno Valley Mall
- Visterra Credit Union
- Yogurtland
- Steer 'n Stein
- Zapata's Mexican Restaurant
- Merck Home Again Microchips
- Olive Garden
- Lasselle Place Apartments
- White's Bikes
- Your Villa Shopping Guide
- City News Group – Moreno Valley City News
- Pop 'n Mama Organic Kettle Corn

These local businesses partnering with the Moreno Valley Animal Shelter is a great example of a public-private partnership that benefits local business, the community and our pets from the Animal Shelter.

The Animal Shelter would like to thank the Parks and Community Services Department for allowing adoptable pets to be highlighted at the City's Summer Concert Series and Movies in the Park. In addition the Animal Shelter would like to thank the City Manager's Office, Media and Communications for their efforts in highlighting the Animal Shelter during the 2013 ASPCA Rachael Ray \$100K Challenge.

June Events

During June 2013, the first month of the ASPCA Rachael Ray \$100K Challenge, the Animal Shelter participated in 8 special adoption events, both on site and at off-site locations, realizing an increase of 49% in the number of dogs adopted along with a 35% reduction in the euthanasia of dogs as compared to June 2012.

July Events

The Animal Shelter participated in the following special events:

- Pet Adoption Event – Moreno Valley Animal Shelter – Sunday, July 7th.
- Moreno Valley Mall's Concert Series – Every Wednesday evening from 6:30 p.m. to 8:30 p.m. on July 10th, 17th, 24th & 31st.
- Movies at the Park hosted by the Parks and Community Services Department every Thursday evening at the CRC Park on July 11th, 18th and 25th.
- 4th of July Parade – Winner of the 2013 Chamber of Commerce Award

CITY COUNCIL GOALS

Positive Environment. Create a positive environment for the development of Moreno Valley's future.

ATTACHMENTS

Attachment 1 – Moreno Valley Animal Shelter Intake /Disposition Report – May 2013

Attachment 2 – Moreno Valley Animal Shelter – May 2013 – Euthanasia Statistics

Attachment 3 – Moreno Valley Animal Shelter Intake / Disposition Report – June 2013

Attachment 4 – Moreno Valley Animal Shelter – June 2013 – Euthanasia Statistics

Prepared By:
Steve Fries
Animal Services Division Manager

Department Head Approval:
Thomas M. DeSantis
Assistant City Manager

Council Action	
Approved as requested:	Referred to:
Approved as amended:	For:
Denied:	Continued until:
Other:	Hearing set for:

**Moreno Valley Animal Shelter
Intake / Disposition Report – May 2013**
Report Date 6/1/2013

Intake	Dogs	Cats	Other	Total
Owner Surrender	48	6	0	54
Live Stray	458	302	27	787
Confiscated (Cruelty/Neglect/Aggressive)	9	2	0	11
Returns	8	3	0	11
Quarantine	2	1	0	3
DOAs	65	53	19	137
On-Hand at Shelter 5/1/13	206	83	4	293
Total	796	450	50	1,296

Disposition	Dogs	Cats	Other	Total
On – Hand At Shelter 6/1/13	211	112	6	329
Escaped/Stolen	3	9	0	12
DOAs	65	53	19	137
Died in Kennel	0	2	0	2
Died at Vet	1	0	0	1
Foster	4	13	0	17
Euthanized	203	249	15	467*
Transfer	0	0	9	9**
Return to Owners	79	3	0	82**
Adopted	230	9	1	240**
Total	796	450	50	1,296

Summary Statistics: The statistics below reflect outcomes on the number of pets placed vs. those which could not be adopted. Figures are based upon the total number of pets available for placement, and does not reflect the number of animals which remained on-hand, or those which were deceased upon arrival and/or while under care. These categories are marked with * above. For the month of May 2013, the number of pets upon which statistics are calculated totaled: 798

*Euthanasia Rates: 59% (467) See Detailed Report
 Unadopted: 3.4% (16)
 Contagious Disease 28.3% (132)
 Medical/Behavioral/Other: 68.3% (319)

**Placement Rate: 41% (331) Reflects Return to Owners, Transfer, Adopted

This page intentionally left blank.

**Moreno Valley Animal Shelter
May 2013 – Euthanasia Statistics**

Outcome Sub-Type	Dogs	Cats	Others	Total
Medical/Vet Rec.	75	22	15	112
Owner Requested	5	0	0	5
Contagious Disease	85	47	0	132
Feral	0	98	0	98
Aggressive Behavior Observed	21	0	0	21
Not Adopted*	16	0	0	16
Other**	1	82	0	83
Total	203	249	15	467

*Not Adopted: euthanized for considerations such as placement potential, time in shelter, humane considerations.

** Other-Cats: too young/newborns-impounded w/o their mothers per Food & Agricultural Code 17006.

This page intentionally left blank.

**Moreno Valley Animal Shelter
Intake / Disposition Report – June 2013**
Report Date 7/1/2013

Intake	Dogs	Cats	Other	Total
Owner Surrender	61	36	1	98
Live Stray	459	293	33	785
Confiscated (Cruelty/Neglect/Aggressive)	24	0	0	24
Returns	7	1	0	8
Quarantine	3	0	0	3
DOAs	41	38	21	100
On-Hand at Shelter 6/1/13	211	112	6	329
Total	806	480	61	1,347

Disposition	Dogs	Cats	Other	Total
On – Hand At Shelter 6/1/13	190	63	1	254
Escaped/Stolen	2	15	0	17
DOAs	41	38	21	100
Died in Kennel	4	3	0	7
Died at Vet	0	0	0	0
Foster	4	15	1	20
Euthanized	254	314	19	587*
Transfer	0	0	14	14**
Return to Owners	78	1	0	79**
Adopted	233	31	5	269**
Total	806	480	61	1,347

Summary Statistics: The statistics below reflect outcomes on the number of pets placed vs. those which could not be adopted. Figures are based upon the total number of pets available for placement, and does not reflect the number of animals which remained on-hand, or those which were deceased upon arrival and/or while under care. These categories are marked with * above. For the month of June 2013, the number of pets upon which statistics are calculated totaled: 949

*Euthanasia Rates: 62% (587) See Detailed Report
 Unadopted: 4% (24)
 Contagious Disease 30% (176)
 Medical/Behavioral/Other: 66% (387)

**Placement Rate: 38% (362) Reflects Return to Owners, Transfer, Adopted

This page intentionally left blank.

**Moreno Valley Animal Shelter
June 2013 – Euthanasia Statistics**

Outcome Sub-Type	Dogs	Cats	Others	Total
Medical/Vet Rec.	100	20	15	135
Owner Requested	6	4	1	11
Contagious Disease	101	75	0	176
Feral	0	107	0	107
Aggressive Behavior Observed	22	0	1	23
Not Adopted*	24	0	0	24
Other**	1	108	2	111
Total	254	314	19	587

*Not Adopted: euthanized for considerations such as placement potential, time in shelter, humane considerations.

** Other-Cats/Dogs/Others: too young/newborns-impounded w/o their mothers per Food & Agricultural Code 17006.

This page intentionally left blank.

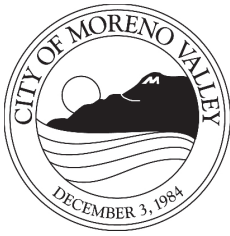

APPROVALS	
BUDGET OFFICER	<i>me</i>
CITY ATTORNEY	<i>SMB</i>
CITY MANAGER	<i>d</i>

Report to City Council

TO: Mayor and City Council

FROM: Jane Halstead, City Clerk

AGENDA DATE: August 27, 2013

TITLE: APPOINT A VOTING DELEGATE AND ALTERNATE DELEGATES FOR THE LEAGUE OF CALIFORNIA CITIES (LCC) 2013 ANNUAL CONFERENCE BUSINESS MEETING

RECOMMENDED ACTION

Recommendation: That the City Council:

1. Appoint a voting delegate, and first and second alternate delegates for the League of California Cities (LCC) 2013 Annual Conference business meeting.

BACKGROUND

The League of California Cities Annual Conference is scheduled for September 18 - 20, 2013, in Sacramento. At this meeting, the League membership will consider and take action on resolutions that establish League policy. The City must designate a voting delegate and may appoint up to two alternate voting delegates, one of whom may vote in the event that the designated voting delegate is unable to serve. Designation of a voting delegate must be done by City Council action.

Council Members Victoria Baca, Jesse L. Molina, and Richard A. Stewart are attending the Conference.

ALTERNATIVES

1. Appoint a voting delegate and first and second alternate delegates for the League of California Cities (LCC) 2013 Annual Conference business meeting.
2. Do not appoint a voting delegate and first and second alternate delegates for the League of California Cities (LCC) 2013 Annual Conference business meeting (not recommended by staff).

NOTIFICATION

Agenda publication

ATTACHMENTS

1. 2013 Annual Conference Voting Delegate/Alternate Form
2. 2013 Annual Conference Resolution Packet

Prepared By:
Cindy Miller
Executive Assistant to the Mayor/City Council

Department Head Approval:
Jane Halstead
City Clerk

Council Action	
Approved as requested:	Referred to:
Approved as amended:	For:
Denied:	Continued until:
Other:	Hearing set for:



CITY: _____

2013 ANNUAL CONFERENCE
VOTING DELEGATE/ALTERNATE FORM

Please complete this form and return it to the League office by Friday, September 13, 2013. Forms not sent by this deadline may be submitted to the Voting Delegate Desk located in the Annual Conference Registration Area. Your city council may designate one voting delegate and up to two alternates.

In order to vote at the Annual Business Meeting (General Assembly), voting delegates and alternates must be designated by your city council. Please attach the council resolution as proof of designation. As an alternative, the Mayor or City Clerk may sign this form, affirming that the designation reflects the action taken by the council.

Please note: Voting delegates and alternates will be seated in a separate area at the Annual Business Meeting. Admission to this designated area will be limited to individuals (voting delegates and alternates) who are identified with a special sticker on their conference badge. This sticker can be obtained only at the Voting Delegate Desk.

1. VOTING DELEGATE

Name: _____

Title: _____

2. VOTING DELEGATE - ALTERNATE

Name: _____

Title: _____

3. VOTING DELEGATE - ALTERNATE

Name: _____

Title: _____

PLEASE ATTACH COUNCIL RESOLUTION DESIGNATING VOTING DELEGATE AND ALTERNATES.

OR

ATTEST: I affirm that the information provided reflects action by the city council to designate the voting delegate and alternate(s).

Name: _____ E-mail _____

Mayor or City Clerk _____ Phone: _____
(circle one) (signature)

Date: _____

Please complete and return by Friday, September 13, 2013

League of California Cities
ATTN: Mary McCullough
1400 K Street
Sacramento, CA 95814

FAX: (916) 658-8240
E-mail: mmccullough@cacities.org
(916) 658-8247

This page intentionally left blank.

July 23, 2013

TO: Mayors, City Managers and City Clerks
League Board of Directors

RE: Annual Conference Resolutions Packet
Notice of League Annual Meeting

Enclosed please find the 2013 Annual Conference Resolutions Packet.

Annual Conference in Sacramento. This year's League Annual Conference will be held September 18 - 20 in Sacramento. The conference announcement has previously been sent to all cities and we hope that you and your colleagues will be able to join us. More information about the conference is available on the League's Web site at www.cacities.org/ac. We look forward to welcoming city officials to the conference.

Annual Luncheon/Business Meeting - Friday, September 20, 12:00 p.m. The League's Annual Business Meeting will be held at the Hyatt Regency Hotel.

Resolutions Packet. At the Annual Conference, the League will consider the two resolutions introduced by the deadline, Saturday, July 20, 2013, midnight. These resolutions are included in this packet. New this year, resolutions submitted to the General Assembly must be concurred in by five cities or by city officials from at least five or more cities. These letters of concurrence are included with this packet. We request that you distribute this packet to your city council.

We encourage each city council to consider the resolutions and to determine a city position so that your voting delegate can represent your city's position on each resolution. A copy of the resolutions packet is posted on the League's website for your convenience: www.cacities.org/resolutions.

The resolutions packet contains additional information related to consideration of the resolutions at the Annual Conference. This includes the date, time and location of the meetings at which resolutions will be considered.

Voting Delegates. Each city council is encouraged to designate a voting delegate and two alternates to represent their city at the Annual Business Meeting. A letter asking city councils to designate their voting delegate and two alternates has already been sent to each city. Copies of the letter, voting delegate form, and additional information are also available at: www.cacities.org/resolutions.

Please Bring This Packet to the Annual Conference
September 18 - 20 — Sacramento



*Annual Conference
Resolutions Packet*

115th Annual Conference



*Sacramento
September 18 - 20, 2013*

ANNUAL CONFERENCE MEETING SCHEDULE FOR RESOLUTIONS

1. Policy Committee Meetings

Wednesday, September 18, 2013
Sheraton Grand Hotel
1230 J Street, Sacramento

Public Safety: 9:00 a.m. – 10:30 a.m.
Environmental Quality: 10:30 a.m. – 12:00 p.m.

2. General Resolutions Committee

Thursday, September 19, 2013, 1:00 p.m.
Sacramento Convention Center
1400 J Street, Sacramento

3. Annual Business Meeting and General Assembly Luncheon

Friday, September 20, 2013, 12:00 p.m.
Hyatt Regency Hotel
1209 L Street, Sacramento

INFORMATION AND PROCEDURES

RESOLUTIONS CONTAINED IN THIS PACKET: The League bylaws provide that resolutions shall be referred by the president to an appropriate policy committee for review and recommendation. Resolutions with committee recommendations shall then be considered by the General Resolutions Committee at the Annual Conference.

This year, two resolutions have been introduced for consideration by the Annual Conference and referred to the League policy committees.

POLICY COMMITTEES: Two policy committees will meet at the Annual Conference to consider and take action on resolutions referred to them. The committees are Environmental Quality and Public Safety. These committees will meet on Wednesday, September 18, 2013, at the Sheraton Grand Hotel in Sacramento. The sponsors of the resolutions have been notified of the time and location of the meetings.

GENERAL RESOLUTIONS COMMITTEE: This committee will meet at 1:00 p.m. on Thursday, September 19, at the Sacramento Convention Center, to consider the reports of the two policy committees regarding the two resolutions. This committee includes one representative from each of the League's regional divisions, functional departments and standing policy committees, as well as other individuals appointed by the League president. Please check in at the registration desk for room location.

ANNUAL LUNCHEON/BUSINESS MEETING/GENERAL ASSEMBLY: This meeting will be held at 12:00 p.m. on Friday, September 20, at the Hyatt Regency Hotel.

PETITIONED RESOLUTIONS: For those issues that develop after the normal 60-day deadline, a resolution may be introduced at the Annual Conference with a petition signed by designated voting delegates of 10 percent of all member cities (47 valid signatures required) and presented to the Voting Delegates Desk at least 24 hours prior to the time set for convening the Annual Business Session of the General Assembly. This year, that deadline is 12:00 p.m., Thursday, September 19. If the petitioned resolution is substantially similar in substance to a resolution already under consideration, the petitioned resolution may be disqualified by the General Resolutions Committee.

Resolutions can be viewed on the League's Web site: www.cacities.org/resolutions.

Any questions concerning the resolutions procedures may be directed to Meg Desmond at the League office: mdesmond@cacities.org or (916) 658-8224

GUIDELINES FOR ANNUAL CONFERENCE RESOLUTIONS

Policy development is a vital and ongoing process within the League. The principal means for deciding policy on the important issues facing cities is through the League's eight standing policy committees and the board of directors. The process allows for timely consideration of issues in a changing environment and assures city officials the opportunity to both initiate and influence policy decisions.

Annual conference resolutions constitute an additional way to develop League policy. Resolutions should adhere to the following criteria.

Guidelines for Annual Conference Resolutions

1. Only issues that have a direct bearing on municipal affairs should be considered or adopted at the Annual Conference.
2. The issue is not of a purely local or regional concern.
3. The recommended policy should not simply restate existing League policy.
4. The resolution should be directed at achieving one of the following objectives:
 - (a) Focus public or media attention on an issue of major importance to cities.
 - (b) Establish a new direction for League policy by establishing general principals around which more detailed policies may be developed by policy committees and the board of directors.
 - (c) Consider important issues not adequately addressed by the policy committees and board of directors.
 - (d) Amend the League bylaws (requires 2/3 vote at General Assembly).

LOCATION OF MEETINGS

Policy Committee Meetings

Wednesday, September 18, 2013
Sheraton Grand Hotel
1230 J Street, Sacramento

Public Safety: 9:00 a.m. – 10:30 a.m.
Environmental Quality: 10:30 a.m. – 12:00 p.m.

General Resolutions Committee

Thursday, September 19, 2013, 1:00 p.m.
Sacramento Convention Center
1400 J Street, Sacramento

Annual Business Meeting and General Assembly Luncheon

Friday, September 20, 2013, 12:00 p.m.
Hyatt Regency Hotel
1209 L Street, Sacramento

KEY TO ACTIONS TAKEN ON RESOLUTIONS

Resolutions have been grouped by policy committees to which they have been assigned.

Number	Key Word Index	Reviewing Body Action		
		1	2	3
		1 - Policy Committee Recommendation to General Resolutions Committee 2 - General Resolutions Committee 3 - General Assembly		

ENVIRONMENTAL QUALITY POLICY COMMITTEE

		1	2	3
1	Water Bond Funds			

PUBLIC SAFETY POLICY COMMITTEE

		1	2	3
2	Public Safety Realignment			

Information pertaining to the Annual Conference Resolutions will also be posted on each committee's page on the League website: www.cacities.org. The entire Resolutions Packet will be posted at: www.cacities.org/resolutions.

KEY TO ACTIONS TAKEN ON RESOLUTIONS (Continued)

KEY TO REVIEWING BODIES

1. Policy Committee
2. General Resolutions Committee
3. General Assembly

Action Footnotes

- * Subject matter covered in another resolution
- ** Existing League policy
- *** Local authority presently exists

KEY TO ACTIONS TAKEN

- A - Approve
- D - Disapprove
- N - No Action
- R - Refer to appropriate policy committee for study
- a - Amend
- Aa - Approve as amended
- Aaa - Approve with additional amendment(s)
- Ra - Amend and refer as amended to appropriate policy committee for study
- Raa - Additional amendments and refer
- Da - Amend (for clarity or brevity) and Disapprove
- Na - Amend (for clarity or brevity) and take No Action
- W - Withdrawn by Sponsor

Procedural Note: Resolutions that are approved by the General Resolutions Committee, as well as all qualified petitioned resolutions, are reported to the floor of the General Assembly. In addition, League policy provides the following procedure for resolutions approved by League policy committees but *not* approved by the General Resolutions Committee:

Resolutions initially recommended for approval and adoption by all the League policy committees to which the resolution is assigned, but subsequently recommended for disapproval, referral or no action by the General Resolutions Committee, shall then be placed on a consent agenda for consideration by the General Assembly. The consent agenda shall include a brief description of the basis for the recommendations by both the policy committee(s) and General Resolutions Committee, as well as the recommended action by each. Any voting delegate may make a motion to pull a resolution from the consent agenda in order to request the opportunity to fully debate the resolution. If, upon a majority vote of the General Assembly, the request for debate is approved, the General Assembly shall have the opportunity to debate and subsequently vote on the resolution.

2013 ANNUAL CONFERENCE RESOLUTIONS

RESOLUTION REFERRED TO ENVIRONMENTAL QUALITY POLICY COMMITTEE

- 1. RESOLUTION CALLING UPON THE GOVERNOR AND THE LEGISLATURE TO WORK WITH THE LEAGUE OF CALIFORNIA CITIES IN PROVIDING ADEQUATE FUNDING AND TO PRIORITIZE WATER BONDS TO ASSIST LOCAL GOVERNMENT IN WATER CONSERVATION, GROUND WATER RECHARGE AND REUSE OF STORMWATER AND URBAN RUNOFF PROGRAMS.**

Source: Los Angeles County Division

Concurrence of five or more cities/city officials: Cities of Alhambra; Cerritos; Claremont; Glendora; Lakewood; La Mirada; La Verne; Norwalk; Signal Hill; Mary Ann Lutz, Mayor, city of Monrovia.

Referred to: Environmental Quality Policy Committee

Recommendations to General Resolutions Committee: Approve

WHEREAS, local governments play a critical role in providing water conservation, ground water recharge and reuse of stormwater infrastructure, including capture and reuse of stormwater for their citizens, businesses and institutions; and

WHEREAS, local governments support the goals of the Clean Water Act to ensure safe, clean water supply for all and the U.S. Environmental Protection Agency has encouraged local governments to implement programs to capture, infiltrate and treat stormwater and urban runoff with the use of low impact development ordinances, green street policies and programs to increase the local ground water supply through stormwater capture and infiltration programs; and

WHEREAS, local governments also support the State's water quality objectives, specifically Section 13241 of the Porter-Cologne Water Quality Control Act, on the need to maximize the use of reclaimed and water reuse and the Regional Water Quality Control Boards and the State Water Resources Board encourage rainwater capture efforts; and

WHEREAS, the State's actions working through the water boards, supported by substantial Federal, State and local investments, have led to a dramatic decrease in water pollution from wastewater treatment plants and other so-called "point sources" since 1972. However, the current threats to the State's water quality are far more difficult to solve, even as the demand for clean water increases from a growing population and an economically important agricultural industry; and

WHEREAS, the State's Little Hoover Commission found in 2009 that more than 30,000 stormwater discharges are subject to permits regulating large and small cities, counties, construction sites and industry. The Commission found that a diverse group of water users – the military, small and large businesses, home builders and local governments and more – face enormous costs as they try to control and limit stormwater pollution. The Commission concluded that the costs of stormwater clean up are enormous and that the costs of stormwater pollution are greater, as beach closures impact the State's economy and environmental damage threatens to impair wildlife; and

WHEREAS, at the same time that new programs and projects to improve water quality are currently being required by the U.S. EPA and the State under the National Pollution Discharge Elimination System (NPDES) permits and the Total Daily Maximum Load (TMDL) programs, many local governments find that they lack the basic infrastructure to capture, infiltrate and reuse stormwater and cities are facing difficult economic challenges while Federal and State financial assistance has been reduced due to the impacts of the recession and slow economic recovery; and

WHEREAS, cities have seen their costs with the new NPDES permit requirements double and triple in size in the past year, with additional costs anticipated in future years. Additionally, many local businesses have grown increasingly concerned about the costs of retrofitting their properties to meet stormwater and runoff requirements required under the NPDES permits and TMDL programs; and

WHEREAS, the League of California Cities adopted water polices in March of 2012, recognizing that the development and operation of water supply, flood control and storm water management, among other water functions, is frequently beyond the capacity of local areas to finance and the League found that since most facilities have widespread benefits, it has become the tradition for Federal, State and local governments to share their costs (XIV, Financial Considerations); and the League supports legislation providing funding for stormwater and other water programs; and

WHEREAS, the Governor and the Legislature are currently contemplating projects for a water bond and a portion of the bond could be directed to assist local government in funding and implementing the goals of the Clean Water Act and the State's water objectives of conserving and reusing stormwater in order to improve the supply and reliability of water supply; and now therefore let it be

RESOLVED by the General Assembly of the League of California Cities, assembled in Sacramento on September 20, 2013, that the League calls for the Governor and the Legislature to work with the League and other stakeholders to provide adequate funding for water conservation, ground water recharge and capture and reuse of stormwater and runoff in the water bond issue and to prioritize future water bonds to assist local governments in funding these programs. The League will work with its member cities to educate federal and state officials to the challenges facing local governments in providing for programs to capture, infiltrate and reuse stormwater and urban runoff.

//////////

Background Information on Resolution No. 1

Source: Los Angeles County Division

Background:

In order to meet the goals of both the Federal Clean Water Act and the State's Porter-Cologne Water Quality Control Act, which seek to ensure safe clean water supplies, cities provide critical water conservation, ground water recharge and reuse of stormwater infrastructure, including capture and reuse of stormwater for their citizens, businesses and institutions.

Working with the State's Regional Water Quality Control Boards and the State Water Resources Board through the National Pollution Discharge Elimination System (NPDES) permitting process and Total Maximum Daily Load (TMDL) Programs, California's cities implement programs to capture, infiltrate and treat stormwater and urban runoff with the use of low impact development ordinances, green streets policies and other programs to increase the local ground water supply.

These actions have led to a dramatic decrease in water pollution from wastewater treatment plants and other so-called "point sources" since the adoption of the Clean Water Act in 1972. However, current threats to the State's "non-point sources" of pollution, such as stormwater and urban runoff are far more difficult to solve, even as the demand for clean water increases from a growing population and an economically important agricultural industry.

Current Problem Facing California's Cities

The Little Hoover Commission found in 2009 that more than 30,000 stormwater discharges are subject to permits regulating large and small cities, counties, construction sites and industry. The Commission found that a diverse group of water users – the military, small and large businesses, home builders and local governments and more – face enormous costs as they try and control and limit stormwater pollution. The Commission concluded that the costs of stormwater clean up are enormous and that the costs of stormwater pollution are greater as beach closures impact the state's economy and environmental damage threatens to impair wildlife.

Additionally, new programs and projects to improve water quality are currently being required by the U.S. EPA and the State under the NPDES permits and the TMDL programs. Many local governments find that they lack the basic infrastructure to capture, infiltrate and reuse stormwater and the cities are facing difficult economic challenges while Federal and State financial assistance has been reduced due to the impacts of the recession and slow economic recovery.

Cities have seen their costs with the new NPDES permit requirements triple in size in the past year, with additional costs anticipated in future years. Additionally, many local businesses have grown increasingly concerned about the costs of retrofitting their properties to meet stormwater and runoff requirements required under the NPDES permits and TMDL programs.

In Los Angeles County alone, reports commissioned by the Los Angeles County Flood Control District estimate the costs of achieving region-wide compliance for implementing TMDL programs in the NPDES permits required by the Los Angeles Regional Water Quality Control Board (LARWQCB) will be in the tens of billions of dollars over the next twenty years. Additionally, failure to comply with the LARWQCB's terms could result in significant Clean Water Act fines, state fines and federal penalties anywhere from \$3,000- \$37,500 per day. Violations can also result in third-party litigation. Such costs are not confined to Los Angeles County and are being realized statewide.

Clearly, compliance with the NPDES permit and TMDL programs will be expensive for local governments over a long period of time and cities lack a stable, long-term, dedicated local funding source to address this need. Many cities are faced with the choice of either cutting existing services or finding new sources of revenue to fund the NPDES and TMDL programs.

Los Angeles County Division Resolution

The Division supports strong League education and advocacy at both the State and Federal levels to help cities face the challenges in providing programs to capture, infiltrate and reuse stormwater and urban runoff. While Los Angeles County cities and other regions seek to secure local funding sources to meet the Clean Water Act and the State's water objectives, it will simply not be enough to meet the enormous costs of compliance. The Los Angeles County Division strongly believes that State and Federal cooperation are necessary to fund programs to secure and reuse stormwater in order to improve water supply and reliability throughout the state.

The Division calls for the League to engage in discussions on 2014 State Water Bond to assist cities in funding and implementing the goals of the Clean Water Act and the State's Water objectives. This resolution does not support the 2014 bond issue, since the League and individual cities will need to make this decision at a later time upon review of the final language. However, the Governor and Legislature have reopened discussions for the 2014 water bond and funding of urban runoff and stormwater programs has taken a back seat in past bond issues, such as Proposition 84. In May, Assembly Speaker John Perez appointed a Water Bond Working Group which recently outlined a new set of Priorities and Accountability Measures for developing a water bond that would gain the support of 2/3 of the Legislature and voters. One of the priorities identified by the committee included, "Regional Self Reliance/Integrated Regional Water

Management,” posing the question if stormwater capture should be included in any future bonds. The Division believes the opportunity to advocate for funding in the bond is now.

//////////

League of California Cities Staff Analysis on Resolution No. 1

Staff: Jason Rhine; (916) 658-8264
Committee: Environmental Quality

Summary:

This resolution seeks to call upon the Governor and the Legislature to work with the League of California Cities in providing adequate funding and to prioritize water bonds to assist local governments in water conservation, ground water recharge and reuse of stormwater and urban runoff programs.

Background:

In 2009, the State Legislature passed and Governor Arnold Schwarzenegger signed a package of legislation that included four policy bills and an \$11.1 billion water bond (The Clean, and Reliable Drinking Water Supply Act). The water bond included the following major spending proposals:

- \$455 million for drought relief projects, disadvantaged communities, small community wastewater treatment improvements and safe drinking water revolving fund
- \$1.4 billion for "integrated regional water management projects"
- \$2.25 billion for projects that "support delta sustainability options"
- \$3 billion for water storage projects
- \$1.7 billion for ecosystem and watershed protection and restoration projects in 21 watersheds
- \$1 billion for groundwater protection and cleanup
- \$1.25 billion for "water recycling and advanced treatment technology projects"

The \$11.1 billion bond also included nearly \$2 billion in earmarks. Projects slated for funding included:

- \$40 million to educate the public about California's water
- \$100 million for a Lake Tahoe Environmental Improvement Program for watershed restoration, bike trails and public access and recreation projects
- \$75 million for the Sierra Nevada Conservancy, for public access, education and interpretive projects
- \$20 million for the Baldwin Hills Conservancy to be used to buy more land
- \$20 million for the Bolsa Chica Wetlands for interpretive projects for visitors

The water bond was originally scheduled to appear on the 2010 ballot as Proposition 18. However, due to significant criticism over the size of the bond, the amount of earmarked projects, and a lack of public support, the Legislature has voted twice to postpone the ballot vote. The water bond is now slated for the November 4, 2014 ballot.

It is unclear whether or not the water bond will actually appear on the November 2014 ballot. In recent months, pressure has been mounting to postpone the water bond yet again or significantly rewrite the water bond to drastically reduce the overall size of the bond and remove all earmarks. The Legislature has until the summer of 2014 to act.

Fiscal Impact:

Unknown. This resolution does not seek a specified appropriation from a water bond.

Existing League Policy:

In 2008, the League formed a new Water Task Force to consider updates and revision to the Water Guidelines the League drafted and adopted 20 years earlier. These new Guidelines were formally approved by the League board of directors in Feb. 2010. Below are the most pertinent policy and guiding principles related to the proposed resolution. To view the entire water policy guidelines, go to www.cacities.org/waterpolicyguidelines.

General Principles

- The League supports the development of additional groundwater and surface water storage, including proposed surface storage projects now under study if they are determined to be feasible, including but not limited to: environmentally, economically, and geographically relating to point of origin. Appropriate funding sources could include, but are not limited to user fees, bonds and federal funding.
- The League supports state water policy that allows undertaking aggressive water conservation and water use efficiency while preserving, and not diminishing, public and constitutional water rights.

Water Conservation

- The League supports the development of a statewide goal to reduce water use by 20% by 2020 through the implementation of fair and equitable measures consistent with these principles.
- Accomplishing water conservation and water use efficiency goals will require statewide action by all water users, including residential, commercial, industrial and agricultural water users, local and regional planning agencies, state and federal agencies, chambers of commerce, and business, commercial and industrial professional and trade associations.

Water Recycling

- Wherever feasible, water recycling should be practiced in urban, industrial and agricultural sectors. This includes increasing the use of recycled water over 2002 levels by at least one million acre-feet/year (afy) by 2020 and by at least two million afy by 2030.
- Increased recycling, reuse and other refinements in water management practices should be included in all water supply programs.

Water Storage

- The development of additional surface facilities and use of groundwater basins to store surface water that is surplus to that needed to maintain State Water Resource Control Board (SWRCB) Bay-Delta estuary water quality standards should be supported.

Groundwater

- The principle that local entities within groundwater basins (i.e., cities, counties, special districts, and the regional water quality control boards) working cooperatively should be responsible for and involved in developing and implementing basin wide groundwater, basin management plans should be supported. The plans should include, but not be limited to: a) protecting groundwater quality; b) identifying means to correct groundwater overdraft; c) implementing better irrigation techniques; d) increasing water reclamation and reuse; and e) refining water conservation and other management practices.
- Financial assistance from state and federal governments should be made available to requesting local agencies to develop and implement their groundwater management plans.

Financial Considerations

- It is recognized that the development and operation of water supply, water conveyance, flood control and stormwater management, water storage, and wastewater treatment facilities is frequently beyond the capability of local areas to finance;

- The League supports legislation to provide funding for stormwater, water and wastewater programs, including a constitutional amendment which would place stormwater fees in the category of water and wastewater fees, for the purposes of Proposition 218 compliance.

Support:

New this year, any resolutions submitted to the General Assembly must be concurred in by five cities or by city officials from at least five or more cities. Those submitting resolutions were asked to provide written documentation of concurrence. The following letters of concurrence were received: cities of Alhambra; Cerritos; Claremont; Glendora; Lakewood; La Mirada; La Verne; Norwalk; Signal Hill; and Mary Ann Lutz, Mayor, city of Monrovia. A letter of support was also received from the California Contract Cities Association.

RESOLUTION REFERRED TO PUBLIC SAFETY POLICY COMMITTEE

- 2. RESOLUTION CALLING UPON THE GOVERNOR AND LEGISLATURE TO ENTER INTO DISCUSSIONS WITH THE LEAGUE AND CALIFORNIA POLICE CHIEFS' ASSOCIATION REPRESENTATIVES TO IDENTIFY AND ENACT STRATEGIES THAT WILL ENSURE THE SUCCESS OF PUBLIC SAFETY REALIGNMENT FROM A LOCAL MUNICIPAL LAW ENFORCEMENT PERSPECTIVE.**

Source: Public Safety Policy Committee

Concurrence of five or more cities/city officials: Cities of Arroyo Grande, Covina; Fontana; Glendora; Monrovia; Ontario; Pismo Beach; and Santa Barbara

Referred to: Public Safety Policy Committee

Recommendation to General Resolutions Committee: Approve

WHEREAS, in October 2011 the Governor proposed the realignment of public safety responsibilities from state prisons to local government as a way to address recent court orders in response to litigation related to state prison overcrowding, and to reduce state expenditures; and

WHEREAS, the Governor stated that realignment needed to be fully funded with a constitutionally protected source of funds if it were to succeed; and

WHEREAS, the Legislature enacted the realignment measures, AB 109 and AB 117, and the Governor signed them into law without full constitutionally protected funding and liability protection for stakeholders; and

WHEREAS, California currently has insufficient jail space, probation officers, housing and job placement programs, medical and mental health facilities, lacks a uniform definition of recidivism; and utilizes inappropriate convictions used to determine inmate eligibility for participation in the realignment program; and

WHEREAS, since the implementation of realignment there have been numerous issues identified that have not been properly addressed that significantly impact municipal police departments' efforts to successfully implement realignment; and

WHEREAS, ultimately many of these probationers who have severe mental illness are released into communities where they continue to commit crimes that impact the safety of community members and drain the resources of probation departments and police departments throughout the state; and

WHEREAS, an estimated 30 counties were operating under court-ordered or self-imposed population caps before realignment, and the current lack of bed space in county jails has since led to many convicted probationers being released early after serving a fraction of their time; with inadequate to no subsequent supervision, leaving them free to engage in further criminal offenses in our local cities; and

WHEREAS, there is increasing knowledge among the offender population which offenses will and will not result in a sentence to state prison, and many offenders, if held in custody pending trial, that would be sentenced to county jail are ultimately sentenced to time served due to overcrowding in county facilities; and

WHEREAS, there are inadequate databases allowing local police departments to share critical offender information among themselves, with county probation departments, and with other county and state law enforcement entities; and

WHEREAS, local police departments have not received adequate funding to properly address this new population of offenders who are victimizing California communities; and now therefore let it be

RESOLVED by the General Assembly of the League of California Cities, assembled in Sacramento on September 20, 2013, to request the Governor and State Legislature to immediately enter into discussions with League representatives and the California Police Chiefs' Association to address the following issues:

1. The need to fully fund municipal police departments with constitutionally protected funding to appropriately address realignment issues facing front-line law enforcement;
2. Amend appropriate sections of AB 109 to change the criteria justifying the release of non-violent, non-serious, non-sex offender inmates (N3) inmates to include their total criminal and mental history instead of only their last criminal conviction;
3. Establish a uniform definition of recidivism with the input of all criminal justice stakeholders throughout the state;
4. Enact legislation that will accommodate the option for city police officers to make ten (10) day flash incarcerations in city jails for probationers who violate the conditions of their probation;
5. Establish oversight procedures to encourage transparency and accountability over the use of realignment funding;
6. Implement the recommendations identified in the California Little Hoover Commission Report #216 dated May 30, 2013;
7. Provide for greater representation of city officials on the local Community Corrections Partnerships. Currently AB 117 provides for only one city official (a police chief) on the seven-member body, six of which are aligned with the county in which the partnership has been established. As a result, the counties dominate the committees and the subsequent distribution of realignment funds.
8. Provide, either administratively or by legislation, an effective statewide data sharing mechanism allowing state and local law enforcement agencies to rapidly and efficiently share offender information to assist in tracking and monitoring the activities of AB 109 and other offenders.

//////////

Background Information on Resolution No. 2

Source: Public Safety Policy Committee

Background:

In October 2011 the Governor proposed the realignment of public safety tasks from State Prisons to local government as a way to address certain judicial orders dealing with State prison overcrowding and to reduce State expenditures. This program shifts the prisoner burden from State prisons to local counties and cities.

When the Governor signed into law realignment he stated that realignment needed to be fully funded with constitutionally protected source of funds to succeed. Nonetheless, the law was implemented without full constitutional protected funding for counties and cities; insufficient liability protections to local agencies; jail space; probation officers; housing and job placement programs; medical and mental health facilities; and with an inappropriate definition of N3 (non-serious, non-sexual, non-violent) criminal convictions used to screen inmates for participation in the program.

Two-thirds of California's 58 counties are already under some form of mandated early release. Currently, 20 counties have to comply with maximum population capacity limits enforced by court order, while another 12 counties have self-imposed population caps to avoid lawsuits.

At this time no one knows what the full impact of realignment will ultimately be on crime. We hope that crime will continue to drop, but with the current experience of the 40,000 offenders realigned since October 2011, and an estimated additional 12,000 offenders being shifted from State prison to local jails and community supervision by the end of fiscal year 2013-14, it will be very difficult to realize lower crime rates in the future.

Beginning in October 2011, California State prisons began moving N3 offenders into county jails, the county probation and court systems, and ultimately funneled them into community supervision or alternative sentencing program in cities where they will live, work, and commit crime.

Note: There is currently no uniform definition of recidivism throughout the state and no database that can deliver statistical information on the overall impact realignment has had on all cities in California. Because of this problem we have used data from Los Angeles County.

The March 4, 2013 report to the Los Angeles County Criminal Justice Coordination Committee (CCJCC) shows a strong effort and progress in addressing the realignment mandate. However, there is insufficient funding.

The report also states the jail population continues to be heavily influenced by participants housed locally. On September 30, 2012, the inmate count in the Los Angeles County Jail was 15,463; on January 31, 2013, the count was 18,864. The realignment population accounted for 32% of the Jail population; 5,743 offenders sentenced per Penal Code Section 1170 (h) and 408 parole violations.

By the end of January 2013, 13,535 offenders were released on Post Release Community Supervision (PRCS) to Los Angeles County including prisoners with the highest maintenance costs because of medical and drug problems and mental health issues costing counties and local cities millions of dollars in unfunded mandates since the beginning of the program. Prisoners with prior histories of violent crimes are also being released without proper supervision. That is why sections of **AB 109 must be amended to change the criteria used to justify the release of N3 inmates to include an offender's total criminal and mental history instead of only their last criminal conviction.** Using the latter as the key criteria does not provide

an accurate risk assessment of the threat these offenders pose to society if they are realigned to county facilities, or placed on Post Release Community Supervision.

Chief Jerry Powers from the Los Angeles County Probation Department recently stated the release criteria for N3 offenders “has nothing to do with reality.” He said initially the State estimated the population of released PRCS offenders would be 50% High Risk, 25% Medium Risk and 25% Low Risk. The reality is 3% are Very High Risk, 55% are High Risk, 40% are Medium Risk and only 2% are Low Risk offenders. He said the High Risk and serious mentally ill offenders being released “are a very scary population.” One of the special needs offenders takes the resources of 20-30 other offenders.

Assistant Sheriff Terri McDonald who is the county Jail Administrator recently stated the Jail has only 30 beds for mentally ill offenders being released – when in fact she actually needs 300 beds to accommodate the volume of serious mentally ill offenders being released that require beds.

Los Angeles County data shows 7,200 released offenders have had some sort of revocation. This number is expected to increase because of a significant increase in the first four months of year two of realignment that totals 83% of the entire first year of the program; 4,300 warrants were issued for offenders; 6,200 offenders have been rearrested; and 1,400 prosecuted. Data reveals one in 10 offenders will test positive for drugs during the first 72 hours after being released knowing they are required to report to a probation officer during that time. Only one in three offenders will successfully complete probation.

There are more than 500 felony crimes that qualify State prison inmates for release under realignment. They will be spending their time in cities with little, if any, supervision.

////////

League of California Cities Staff Analysis on Resolution No. 2

Staff: Tim Cromartie (916) 658-8252
Committee: Public Safety Policy Committee

Summary:

This Resolution seeks to outline the deficiencies in the State’s current public safety realignment policy, as implemented in 2011 by AB 109, and to identify policy changes that will assist State, county and municipal law enforcement entities to cope with the expanded universe of offenders that are now being directed to county facilities, resulting in increased related impacts on both local communities and municipal law enforcement.

Background:

This resolution was brought to the Public Safety Policy Committee by individual members of that committee who are increasingly concerned about municipal public safety impacts resulting from county jail overcrowding, a problem that has intensified with realignment, resulting in certain categories of offenders doing no jail time or being sentenced to time served. This has created a climate in which some offenses receive little or no jail time, accompanied by a growing body of anecdotal evidence that property crimes have correspondingly increased, with some, such as auto theft, being committed in serial fashion. Increased criminal activity has strained the resources of many local police departments already struggling to more closely coordinate information sharing with county probation offices to effectively monitor offenders on post-community release supervision.

In addition, there is growing concern about the criteria established for determining which offenders are eligible for post-release community supervision (the non-violent, non-serious, non-sex offenders). There is so much concern that a May 2013 report of California’s Little Hoover Commission recommended adjusting

the criteria to examine an offender's total criminal history rather than merely his or her last known offense, as a means of more accurately assessing the risk he or she might pose to the community.

Implementation of the realignment policy is handled in part by the Community Corrections Partnerships established by AB 109, which currently have only one city representative, compared to at least four county-level representatives.

Fiscal Impact:

Unknown impact on the State General Fund. This resolution seeks to establish increased and constitutionally protected funding for city police departments (and county sheriff's departments, to the degree they are contracted to provide police services for cities), but does not specify a dollar amount for the revenue stream. At a minimum, it would entail an annual revenue stream of at least the amount provided for cities for front-line law enforcement in the State's 2013-14 Budget, \$27.5 million, indefinitely – although that revenue stream has never been formally identified by the Brown Administration as having any direct connection to realignment.

Existing League Policy:

Related to this resolution, existing policy provides:

- The League supports policies establishing restrictions on the early release of state inmates for the purpose of alleviating overcrowding, and limiting parole hearing opportunities for state inmates serving a life sentence, or paroled inmates with a violation.
- The League supports increasing municipal representation on and participation in the Community Corrections Partnerships, which are charged with developing local corrections plans.
- In addition, the Strategic Priorities for 2012, as adopted by the League Board of Directors, included the promotion of local control for strong cities. The resolution's objectives of locking in ongoing funding for front-line municipal law enforcement, and increasing city participation in the Community Corrections Partnerships, are consistent with promoting local control.

Support:

New this year, any resolutions submitted to the General Assembly must be concurred in by five cities or by city officials from at least five or more cities. Those submitting resolutions were asked to provide written documentation of concurrence. The following cities/city officials have concurred: cities of Arroyo Grande; Covina; Fontana; Glendora; Monrovia; Ontario; Pismo Beach; and Santa Barbara.

LETTERS OF CONCURRENCE

Resolution #1
Water Bond Funds

City of Alhambra
Office of the Mayor and City Council

July 1, 2013

Bill Bogaard
President
League of California Cities
1400 K Street, Suite 400
Sacramento, CA 95814

RE: Los Angeles County Division Annual Conference Resolution

Dear President Bogaard:

The City of Alhambra supports the Los Angeles County Division's effort to submit a resolution for consideration by the General Assembly at the League's 2013 Annual Conference in Sacramento.

The Division's resolution seeks to address a critical funding need for cities working to meet the State's water quality objectives and storm water management plans by providing direction for the League to educate state leaders and advocate for funding during discussions on the 2014 Water Bond. The City of Alhambra is anticipating spending \$24,101.96 this year to start the development of the Enhanced Watershed Plan and monitoring plan. Prior to 2016, the City anticipates spending \$1,169,000 for full capture device on our storm drain catch basins. In the future, it is estimated the city may need \$34 million dollars to finance the required infrastructure to meet the new permit guidelines. We also anticipate needing to hire additional staff to monitor and maintain the program. None of these costs have a dedicated funding source.

As members of the League, our city values the policy development process provided to the General Assembly. We appreciate your time on this issue. Please feel free to contact Mary Chavez, Director of Public Works, at (626) 570-5067 if you have any questions.

Very truly yours,

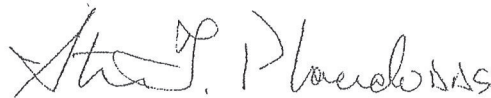

Steven Placido, DDS
Mayor

cc: Jennifer Quan, League of California Cities



Gateway
to the
San Gabriel Valley

111
South First Street
Alhambra
California
91801

626
570-5010

FAX
281-2248



CITY OF CERRITOS

CIVIC CENTER • 18125 BLOOMFIELD AVENUE
P.O. BOX 3130 • CERRITOS, CALIFORNIA 90703-3130
PHONE: (562) 916-1310 • FAX: (562) 468-1095
CELL PHONE: (562) 547-1732
E-mail: bbarr90703@aol.com
WWW.CERRITOS.US



OFFICE OF THE MAYOR
BRUCE W. BARROWS

July 8, 2013

Bill Bogaard
President
League of California Cities
1400 K Street, Suite 400
Sacramento, CA 95814

RE: Los Angeles County Division Annual Conference Resolution

President Bogaard: *Bill*

The City of Cerritos supports the Los Angeles County Division's effort to submit a resolution for consideration by the General Assembly at the League's 2013 Annual Conference in Sacramento.

The Division's resolution seeks to address a critical funding need for cities working to meet the State's water quality objectives and storm water management plans by providing direction for the League to educate state leaders and advocate for funding during discussions on the 2014 Water Bond. The City of Cerritos expended \$866,000 in the Fiscal Year 2011-2012 for compliance with required stormwater programs. Future expenditures are expected to be over \$1.5 million annually, as the City will be required to begin construction of costly stormwater capital improvements.

As members of the League our city values the policy development process provided to the General Assembly. We appreciate your time on this issue. Please feel free to contact Art Gallucci, City Manager at (562)916-1301 or agallucci@cerritos.us, if you have any questions.

Sincerely,

Bruce W. Barrows
MAYOR

cc: Ling-Ling Chang, President, Los Angeles County Division c/o
Robb Korinke, Executive Director, Los Angeles County Division, robb@laciities.org



CITY OF CLAREMONT

City Hall
207 Harvard Avenue
P.O. Box 880
Claremont, CA 91711-0880
Fax: (909) 399-5492
Website: www.ci.claremont.ca.us
Email: contact@ci.claremont.ca.us

City Council • (909) 399-5444
Corey Calaycay
Joseph M. Lyons
Opanyi K. Nasiali
Sam Pedroza
Larry Schroeder

July 1, 2013

Bill Bogaard
President
League of California Cities
1400 K Street, Suite 400
Sacramento, CA 95814

President Bogaard:

**RE: Los Angeles County Division Proposed Resolution for LCC Approval
At The 2013 Annual Conference**

The City of Claremont supports the Los Angeles County Division's effort to submit a resolution for consideration by the General Assembly at the League's 2013 Annual Conference in Sacramento.

The Division's resolution seeks to address a critical funding need for cities working to meet the State's water quality objectives and storm water management plans by providing direction for the League to educate state leaders and advocate for funding during discussions on the 2014 Water Bond.

As members of the League, our City values the policy development process provided to the General Assembly and appreciates your time on this issue. If you have any questions, please feel free to contact Tony Ramos, City Manager, at (909) 399-5441.

Sincerely,

Opanyi Nasiali
Mayor

c: Jennifer Quan, League of California Cities

v:/TMoreno/City Council/Letters/LCC Annual Conf Approval Ltr-ON-July'13



CITY OF GLENDORA CITY HALL

(626) 914-8200

116 East Foothill Blvd., Glendora, California 91741
www.ci.glendora.ca.us

July 15, 2013

Bill Bogaard, President
League of California Cities
1400 K Street, Suite 400
Sacramento, CA 95814

RE: Los Angeles County Division Annual Conference Resolution

President Bogaard:

The City of Glendora supports the Los Angeles County Division's effort to submit a resolution for consideration by the General Assembly at the League's 2013 Annual Conference in Sacramento.

The Division's resolution seeks to address a critical funding need for cities working to meet the State's water quality objectives and storm water management plans by providing direction for the League to educate state leaders and advocate for funding during discussions on the 2014 Water Bond.

As members of the League our city values the policy development process provided to the General Assembly. We appreciate your time on this issue. Please feel free to contact me, if you have any questions.

Sincerely,

Joe Santoro, Mayor

cc: Ling-Ling Chang, President, Los Angeles County Division c/o Robb Korinke,
Executive Director, Los Angeles County Division, robb@lacity.org
Jennifer Quan, Regional Public Affairs Manager, League of California Cities -
jqun@cacities.org

PRIDE OF THE FOOTHILLS

Todd Rogers
Vice Mayor

Jeff Wood
Council Member

Diane DuBois
Council Member

Ron Piazza
Council Member

July 2, 2013

CITY OF LAKEWOOD

CALIFORNIA

Steve Croft
Mayor

Mr. Bill Bogaard
President
League of California Cities
1400 K Street, Suite 400
Sacramento, California 95814

RE: Los Angeles County Division Annual Conference Resolution - Support

Dear President Bogaard:

The City of Lakewood supports the Los Angeles County Division's effort to submit a resolution for consideration by the General Assembly at the League's 2013 Annual Conference in Sacramento.

The Division's resolution seeks to address a critical funding need for cities working to meet the State's water quality objectives and storm water management plans by providing direction for the League to educate state leaders and advocate for funding during discussions on the 2014 Water Bond.

For Lakewood, the initial cost alone to prepare the Watershed Management Plan (WMP), Coordinated Integrated Management Plan (CIMP), and Reasonable Assurance Modeling for the three watersheds that Lakewood is a part of is estimated to be \$153,167. This cost does not include administration costs, monitoring costs, construction costs, or inspection costs, which are estimated to be in the millions of dollars.

As members of the League our city values the policy development process provided to the General Assembly. We appreciate your time on this issue. Please feel free to contact Paolo Beltran, Senior Management Analyst, at (562) 866-9771, extension 2140, or email at pbeltran@lakewoodcity.org, if you have any questions.

Sincerely,

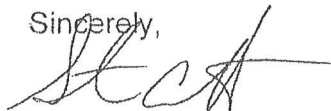

Steve Croft
Mayor

cc: Ling-Ling Chang, President, Los Angeles County Division c/o
Robb Korinke, Executive Director, Los Angeles County Division,
robb@iacities.org

Lakewood



CITY OF LA MIRADA
DEDICATED TO SERVICE

13700 La Mirada Boulevard
La Mirada, California 90638
P.O. Box 828
La Mirada, California 90637-0828
Phone: (562) 943-0131 Fax: (562) 943-1464
www.cityoflamirada.org

July 15, 2013

LETTER OF SUPPORT

Bill Bogaard
President
League of California Cities
1400 K Street, Suite 400
Sacramento, CA 95814

SUBJECT: LOS ANGELES COUNTY DIVISION ANNUAL CONFERENCE RESOLUTION

Dear President Bogaard:

On behalf of the City of La Mirada, I am writing to express support for the League of California Cities, Los Angeles County Division's effort to submit a resolution for consideration by the League's General Assembly at the September 2013 Annual Conference in Sacramento.

The Division's resolution seeks to address a critical funding need for local governments working to meet Federal and State objectives to protect water resources and storm water management plans. The resolution also provides direction for the League to educate State leaders and advocates for the inclusion of storm water funding in the State's proposed 2014 Water Bond.

Like many cities, the City of La Mirada does not have the basic infrastructure to capture, filter, and reuse storm water, and Federal and State funding to assist in providing this infrastructure has been reduced in recent years as a result of the economic recession. Compliance with the MS-4 permit and other storm water regulations could cost the City millions, and reduce funding for other vital City services such as infrastructure and public safety. The City could also face steep fines, penalties, and third party lawsuits if it is unable to meet the National Pollutant Discharge Elimination Systems (NPDES) permit requirements. Receiving State funding could help alleviate the financial burden placed on local governments to meet storm water requirements.

As a member of the League, our City values the policy development process provided to the General Assembly. Please contact Jeff Boynton, Deputy City Manager, at (562) 943-0131 if you have any questions.

Sincerely,

CITY OF LA MIRADA

Steve De Ruse
Mayor

TER:jb:vdr

cc: Ling-Ling Chang, President, Los Angeles County Division
Robb Korinke, Executive Director, Los Angeles County Division



CITY OF LA VERNE CITY HALL

3660 "D" Street, La Verne, California 91750-3599
www.ci.la-verne.ca.us

July 2, 2013

Bill Bogaard, President
League of California Cities
1400 K Street, Suite 400
Sacramento, CA 95814

RE: Los Angeles County Division Annual Conference Resolution

President Bogaard:

The City of La Verne supports the Los Angeles County Division's effort to submit a resolution for consideration by the General Assembly at the League's 2013 Annual Conference in Sacramento.

The Division's resolution seeks to address a critical funding need for cities working to meet the State's water quality objectives and storm water management plans by providing direction for the League to educate state leaders and advocate for funding during discussions on the 2014 Water Bond. While the City is still in the process of identifying the costs associated with meeting the new requirements of the MS-4 PERMIT, it is expected these measures will far exceed existing local resources.

As members of the League, our city values the policy development process provided to the General Assembly. We appreciate your time on this issue. Please feel free to contact our City Manager, Bob Russi at 909-596-8726, if you have any questions.

Sincerely,

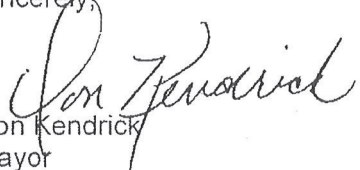
Don Kendrick
Mayor

cc: Jennifer Quan, League of California Cities
JR Ranells, Senior Management Analyst

U:\My Documents\CITY COUNCIL\DON KENDRICK\Support 2013 League Conf Reso.doc

SISTER CITIES
Acapulco, Mexico
Etchmiadzin, Armenia
Skopelos, Greece

General Administration 909/596-8726 • Water Customer Service 909/596-8744 • Parks & Community Services 909/596-8700
Public Works 909/596-8741 • Finance 909/596-8716 • Community Development 909/596-8706 • Building 909/596-8713
Police Department 909/596-1913 • Fire Department 909/596-5991 • General Fax 909/596-8737

LUIGI VERNOLA
Mayor
MARCEL RODARTE
Vice Mayor
CHERI KELLEY
Councilmember
MICHAEL MENDEZ
Councilmember
LEONARD SHRYOCK
Councilmember
MICHAEL J. EGAN
City Manager



12700 NORWALK BLVD., P.O. BOX 1030, NORWALK, CA 90651-1030 * PHONE: 562/929-5700 * FACSIMILE: 562/929-5773 * WWW.NORWALKCA.GOV

July 2, 2013

Bill Bogaard, President
League of California Cities
1400 K Street, Suite 400
Sacramento, CA 95814

RE: Los Angeles County Division Annual Conference Resolution

Dear President Bogaard:

The city of Norwalk supports the Los Angeles County Division's effort to submit a resolution for consideration by the General Assembly at the League's 2013 Annual Conference in Sacramento.

The Division's resolution seeks to address a critical funding need for cities working to meet the State's water quality objectives and storm water management plans by providing direction for the League to educate state leaders and advocate for funding during discussions on the 2014 Water Bond. The cost of compliance with the new storm water permit is in the millions of dollars. The Watershed Management Plan alone will cost close to \$1M. Implementation of projects in the near future based on that Watershed Management Plan could potentially cost the City of Norwalk \$5 - \$10 million annually.

As members of the League our City values the policy development process provided to the General Assembly. We appreciate your time on this issue. Please feel free to contact Mike Egan, City Manager, at (562) 929-5772 if you have any questions.

Sincerely,

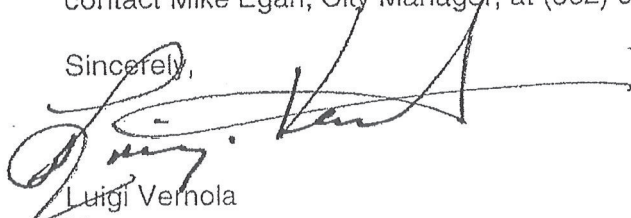

Luigi Vernola
Mayor

cc: Ling-Ling Chang, President, Los Angeles County Division c/o
Robb Korinke, Executive Director, Los Angeles County Division, robb@lacity.org



CITY OF SIGNAL HILL

2175 Cherry Avenue • Signal Hill, California 90755-3799

June 27, 2013

Bill Bogaard
President
League of California Cities
1400 K Street, Suite 400
Sacramento, CA 95814

RE: Los Angeles County Division Annual Conference Resolution

President Bogaard:

The city of Signal Hill supports the Los Angeles County Division's effort to submit a resolution for consideration by the General Assembly at the League's 2013 Annual Conference in Sacramento.

The Division's resolution seeks to address a critical funding need for cities working to meet the State's water quality objectives and storm water management plans by providing direction for the League to educate state leaders and advocate for funding during discussions on the 2014 Water Bond. The city of Signal Hill currently budgets for \$755,000 annually for compliance with required stormwater programs, which represents over 4% of the entire General Fund. Future expenditures are expected to be over \$1.5 million annually, as the City will be required to begin construction of costly stormwater capital improvements.

As members of the League our city values the policy development process provided to the General Assembly. We appreciate your time on this issue. Please feel free to contact Ken Farfsing, City Manager at (562) 989-7302 or kfarfsing@cityofsignal.org, if you have any questions.

Sincerely,

Michael J. Noll
Mayor

CC: Ling-Ling Chang, President, Los Angeles County Division c/o
Robb Korinke, Executive Director, Los Angeles County Division, robb@lacities.org

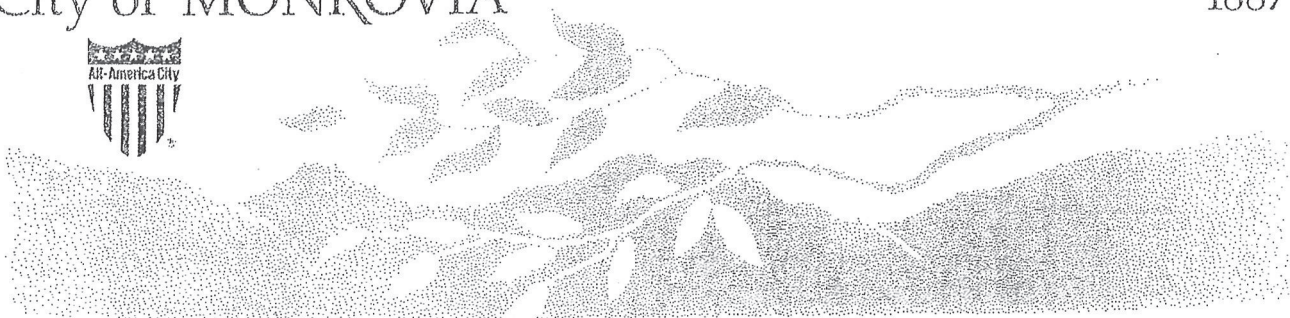

Office of the Mayor and the City Council

July 2, 2013

Bill Bogaard
President
League of California Cities
1400 K Street, Suite 400
Sacramento, CA 95814

SUBJECT: Los Angeles County Division Annual Conference Resolution

Dear President Bogaard:

As Mayor of the City of Monrovia, I support the Los Angeles County Division's effort to submit a resolution for consideration by the General Assembly at the League's 2013 Annual Conference in Sacramento.

The Division's resolution seeks to address a critical funding need for cities working to meet the State's water quality objectives and storm water management plans by providing direction for the League to educate state leaders and advocate for funding during discussions on the 2014 Water Bond. The City is anticipating millions of dollars in stormwater permit compliance costs over the next five years – funds the City currently does not have available. Funding assistance is vital in order for the City to meet stormwater permit requirements.

As members of the League, our City values the policy development process provided to the General Assembly. We appreciate your time on this issue. Please feel free to contact Heather Maloney, Senior Management Analyst, at (626) 932-5577 or hmaloney@ci.monrovia.ca.us, if you have any questions.

Sincerely,

A handwritten signature in cursive script that reads "Mary Ann Lutz".

Mary Ann Lutz,
Mayor

cc: City Council
Ling-Ling Chang, President, Los Angeles County Division c/o
Robb Korinke, Executive Director, Los Angeles County Division, robb@lacities.org
Laurie K. Lile, City Manager
Ron Bow, Director of Public Works



EXECUTIVE BOARD

PRESIDENT
STEVE TYE
Diamond Bar

VICE PRESIDENT
VICTOR MANALO
Artesia

SECRETARY/TREASURER
GUSTAVO CAMCHO
Pico Rivera

PAST PRESIDENT
DIANE J. MARTINEZ
Paramount

DIRECTOR AT LARGE
JEFF WOOD
Lakewood

DIRECTOR AT LARGE
SANDRA ARMENTA
Rosemead

BUDGET & AUDIT COMMITTEE
MICHAEL DAVITT
La Cañada Flintridge

BY-LAWS COMMITTEE
LOU LA MONTE
Malibu

CITY MGRS/ADM. COMMITTEE
JIM DESTEFANO
Diamond Bar

LEGAL/CITY-COUNTY
CONTRACTS COMMITTEE
NANCY TRAGARZ
Walnut

LEGISLATIVE COMMITTEE
SAM PEDROZA
Claremont

MEMBERSHIP COMMITTEE
ANDREW SAREGA
La Mirada

RESOLUTIONS COMMITTEE
BARU SANCHEZ
Cudahy

SELECTIONS COMMITTEE
LIZ REILLY
Duarte

SPECIAL EVENTS COMMITTEE
JAMES R. BOZAJIAN
Calabasas

ASSOCIATE MEMBERS COMMITTEE
FRANK V. ZERUNYAN
Rolling Hills Estates

EXECUTIVE DIRECTOR
SAM OLIVITO

June 20, 2013

Bill Bogaard
President
League of California Cities
1400 K Street, Suite 400
Sacramento, CA 95814

RE: Los Angeles County Division Annual Conference Resolution

President Bogaard:

The California Contract Cities Association supports the Los Angeles County Division's effort to submit a resolution for consideration by the General Assembly at the League's 2013 Annual Conference in Sacramento.

The Division's resolution seeks to address a critical funding need for cities working to meet the State's water quality objectives and storm water management plans by providing direction for the League to educate state leaders and advocate for funding during discussions on the 2014 Water Bond. All of the 58 cities we represent can ill afford this increasingly expensive ongoing cost.

As members of the League our association values the policy development process provided to the General Assembly. We appreciate your time on this issue. Please feel free to contact our office at (562) 622-5533 if you have any questions.

Sincerely,

Steve Tye
CCCA President

CC: Ling-Ling Chang, President, Los Angeles County Division c/o
Robb Korinke, Executive Director, Los Angeles County Division, robb@lacity.org

LETTERS OF CONCURRENCE

Resolution #2

Public Safety Realignment

OFFICE OF THE
MAYOR



300 East Branch Street
Arroyo Grande, CA 93420
Phone: (805) 473-5400
FAX: (805) 473-0386
agcity@arroyogrande.org
www.arroyogrande.org

July 17, 2013

Bill Bogaard, President
League of California Cities
1400 K Street, Suite 400
Sacramento, CA 95814

RE: Public Safety Realignment Resolution

Dear President Bogaard:

On behalf of the City of Arroyo Grande, I am writing to express support for the League of California Cities' Public Safety Resolution, which will be submitted for consideration by the League's General Assembly at the September 2013 Annual Conference in Sacramento.

The League's Resolution seeks to highlight a number of deficiencies with the current public safety realignment policy, and what funding and policy changes need to occur in response. The resolution specifically calls out the need for ongoing local law enforcement funding related to realignment, as well as modification of the criteria for which offenders are eligible for post-release community supervision, i.e. a non-violent, non-serious, non-sex offender criteria that focuses on total criminal history rather than merely the last recorded offense.

As a member of the League, our City values the policy development process provided to the General Assembly. Please contact our City Manager, Steve Adams, at (805)473-5404, if you have any questions.

Sincerely,

Tony Ferrara

Mayor, City of Arroyo Grande



CITY OF COVINA

125 East College Street • Covina, California 91723-2199
www.covinaca.gov

July 17, 2013

Bill Bogaard, President
League of California Cities
1400 K Street, Suite 400
Sacramento, California 95814

RE: Public Safety Realignment Resolution

Dear President Bogaard:

On behalf of the City of Covina, I am writing to express support for the League of California Cities' Public Safety Resolution, which will be submitted for consideration by the League's General Assembly at the September 2013 Annual Conference in Sacramento.

The League's Resolution seeks to highlight a number of deficiencies with the current public safety realignment policy, and what funding and policy changes need to occur in response. The resolution specifically calls out the need for ongoing local law enforcement funding related to realignment, as well as modification of the criteria for which offenders are eligible for post-release community supervision, i.e. a non-violent, non-serious, non-sex offender criteria that focuses on total criminal history rather than merely the last recorded offense.

As a member of the League, our City values the policy development process provided to the General Assembly. Please contact Daryl Parrish, City Manager, at (626) 384-5410, if you have any questions.

Sincerely,

Walter Allen III
Mayor, City of Covina

The City of Covina provides responsive municipal services and manages public resources to enhance the quality of life for our community.



Mayor Acquanetta Warren



July 17, 2013

Bill Bogaard, President
League of California Cities
1400 K Street, Suite 400
Sacramento, California 95814

RE: Public Safety Realignment Resolution

Dear President Bogaard:

On behalf of the City of Fontana, I am writing to express support for the League of California Cities' Public Safety Resolution, which will be submitted for consideration by the League's General Assembly at the September 2013 Annual Conference in Sacramento.

The League's Resolution seeks to highlight a number of deficiencies with the current public safety realignment policy, and what funding and policy changes need to occur in response. The resolution specifically calls out the need for ongoing local law enforcement funding related to realignment, as well as modification of the criteria for which offenders are eligible for post-release community supervision, i.e. a non-violent, non-serious, non-sex offender criteria that focuses on total criminal history rather than merely the last recorded offense.

As a member of the League, our City values the policy development process provided to the General Assembly. Please contact Ken Hunt City Manager, at (909)350-7654, if you have any questions.

Sincerely,

Mayor, City of Fontana

AW/ac



CITY OF GLENDORA CITY HALL

(626) 914-8201

OFFICE OF THE MAYOR

116 East Foothill Blvd., Glendora, California 91741

FAX (626) 914-8221

www.ci.glendora.ca.us

July 19, 2013

Bill Bogaard, President
League of California Cities
1400 K Street, Suite 400
Sacramento, California 95814

RE: Public Safety Realignment Resolution

Dear President Bogaard:

On behalf of the City of Glendora, I am writing to express support for the League of California Cities' Public Safety Resolution, which will be submitted for consideration by the League's General Assembly at the September 2013 Annual Conference in Sacramento.

The League's Resolution seeks to highlight a number of deficiencies with the current public safety realignment policy, and what funding and policy changes need to occur in response. The resolution specifically calls out the need for ongoing local law enforcement funding related to realignment, as well as modification of the criteria for which offenders are eligible for post-release community supervision, i.e. a non-violent, non-serious, non-sex offender criteria that focuses on total criminal history rather than merely the last recorded offense.

As a member of the League, our City values the policy development process provided to the General Assembly. Please contact Chris Jeffers, City Manager, at cjeffers@ci.glendora.ca.us or (626) 914-8201, if you have any questions.

Sincerely,

City of Glendora

Joe Santoro
Mayor

PRIDE OF THE FOOTHILLS



Office of the Mayor and the City Council

July 19, 2013

Bill Bogaard, President
League of California Cities
1400 K Street, Suite 400
Sacramento, California 95814

RE: PUBLIC SAFETY REALIGNMENT RESOLUTION

Dear President Bogaard:

As Mayor of the City of Monrovia, I am writing to express support for the League of California Cities' Public Safety Resolution, which will be submitted for consideration by the League's General Assembly at the September 2013 Annual Conference in Sacramento.

The League's Resolution seeks to highlight a number of deficiencies with the current public safety realignment policy, and what funding and policy changes need to occur in response. The resolution specifically calls out the need for ongoing local law enforcement funding related to realignment, as well as modification of the criteria for which offenders are eligible for post-release community supervision, i.e. a non-violent, non-serious, non-sex offender criteria that focuses on total criminal history rather than merely the last recorded offense.

As a member of the League, our City values the policy development process provided to the General Assembly. Please contact Laurie Lile, City Manager, at (626) 932-5501, if you have any questions.

Sincerely,

Mary Ann Kutz
Mayor

cc: City Council
James Hunt, Police Chief

CITY OF



ONTARIO

303 EAST "B" STREET, CIVIC CENTER

ONTARIO

CALIFORNIA 91764-4105

(909) 395-2000
FAX (909) 395-2070

PAUL S. LEON
MAYOR

CHRIS HUGHES
CITY MANAGER

JIM W. BOWMAN
MAYOR PRO TEM

July 18, 2013

MARY E. WIRTES, MMC
CITY CLERK

ALAN D. WAPNER
DEBRA DORST-PORADA
PAUL VINCENT AVILA
COUNCIL MEMBERS

JAMES R. MILHISER
TREASURER

Bill Bogaard, President
League of California Cities
1400 K Street, Suite 400
Sacramento, California 95814

RE: Public Safety Realignment Resolution

Dear President Bogaard:

On behalf of the City of Ontario, I am writing to express support for the League of California Cities' Public Safety Resolution, which will be submitted for consideration by the League's General Assembly at the September 2013 Annual Conference in Sacramento.

The League's Resolution seeks to highlight a number of deficiencies with the current public safety realignment policy, and what funding and policy changes need to occur in response. The resolution specifically calls out the need for ongoing local law enforcement funding related to realignment, as well as modification of the criteria for which offenders are eligible for post-release community supervision; i.e., a non-violent, non-serious, non-sex offender criteria that focuses on total criminal history rather than merely the last recorded offense.

As a member of the League, our City values the policy development process provided to the General Assembly. Please contact Chris Hughes, City Manager, at (909) 395-2010, if you have any questions.

Sincerely,

PAUL S. LEON
Mayor



From the Office of the Mayor
Shelly Higginbotham
760 Mattie Road
Pismo Beach, CA 93449
(805) 235-6604
shigginbotham@pismo-beach.org

July 18, 2013

Bill Bogaard, President
League of California Cities
1400 K Street, Suite 400
Sacramento, California 95814

RE: Public Safety Realignment Resolution

Dear President Bogaard:

On behalf of the City of Pismo Beach, I am writing to express support for the League of California Cities' Public Safety Resolution, which will be submitted for consideration by the League's General Assembly at the September 2013 Annual Conference in Sacramento.

The League's Resolution seeks to highlight a number of deficiencies with the current public safety realignment policy, and what funding and policy changes need to occur in response. The resolution specifically calls out the need for ongoing local law enforcement funding related to realignment, as well as modification of the criteria for which offenders are eligible for post-release community supervision, i.e. a non-violent, non-serious, non-sex offender criteria that focuses on total criminal history rather than merely the last recorded offense.

As a member of the League, our City values the policy development process provided to the General Assembly. Please contact James R. Lewis, City Manager, at (805) 773-7007, if you have any questions.

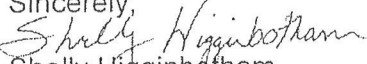
Sincerely,

Shelly Higginbotham
Mayor



City of Santa Barbara

Office of Mayor

HSchneider@SantaBarbaraCA.gov

www.SantaBarbaraCA.gov

July 19, 2013

Helene Schneider
Mayor

Bill Bogaard, President
League of California Cities
1400 K Street, Suite 400
Sacramento, California 95814

City Hall
735 Anacapa Street
Santa Barbara, CA
93101-1990

RE: Public Safety Realignment Resolution

Dear President Bogaard:

Mailing Address:
P.O. Box 1990
Santa Barbara, CA
93102-1990

Tel: 805.564.5323
Fax: 805.564.5475

On behalf of the City of Santa Barbara, I am writing to express support for the League of California Cities' Public Safety Resolution, which will be submitted for consideration by the League's General Assembly at the September 2013 Annual Conference in Sacramento.

The League's Resolution seeks to highlight a number of deficiencies with the current public safety realignment policy, and what funding and policy changes need to occur in response. The resolution specifically calls out the need for ongoing local law enforcement funding related to realignment, as well as modification of the criteria for which offenders are eligible for post-release community supervision, i.e. a non-violent, non-serious, non-sex offender criteria that focuses on total criminal history rather than merely the last recorded offense.

It is important to our City, that such state-mandated programs remain fully-funded and that the regulations do not impede our law enforcement officers' ability to use their professional discretion in protecting our community.

As a member of the League, our City values the League's leadership and policy direction on this issue.

Sincerely,

Helene Schneider,
Mayor

cc: Dave Mullinax, League of California Cities



Please consider the environment before printing this letter.

This page intentionally left blank.

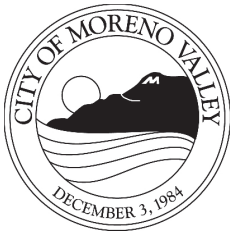

APPROVALS	
BUDGET OFFICER	<i>me</i>
CITY ATTORNEY	<i>SMB</i>
CITY MANAGER	<i>d</i>

Report to City Council

TO: Mayor and City Council

FROM: Jane Halstead, City Clerk

AGENDA DATE: August 27, 2013

TITLE: 2013 COUNCIL COMMITTEE PARTICIPATION APPOINTMENTS TO VACANT POSITIONS

RECOMMENDED ACTION

Recommendations: That the City Council:

1. Appoint Council Member Victoria Baca to serve as the City of Moreno Valley's representative on the March Joint Powers Commission (MJPC).
2. Appoint Council Member Jesse L. Molina to serve as the City of Moreno Valley's alternate representative on the Riverside County Transportation Commission (RCTC).
3. Appoint Council Member Victoria Baca to serve as the City of Moreno Valley's alternate representative on the Riverside Transit Agency (RTA).
4. Appoint Council Member Jesse L. Molina to serve as the City of Moreno Valley's alternate representative on the Western Riverside Council of Governments (WRCOG).
5. Appoint Council Member Jesse L. Molina to serve on the City of Moreno Valley's Economic Development Subcommittee.
6. Appoint Council Member Jesse L. Molina to serve on the City of Moreno Valley's Finance Subcommittee.
7. Appoint Council Member Victoria Baca to serve as the alternate on the City of Moreno Valley's Public Safety Subcommittee.

BACKGROUND

Mayor Owings compiled the 2013 Council Committee Participation list to fill the vacant positions due to the resignation of City Council District 4 representative Marcelo Co.

It was also determined it would be appropriate for the City Council to make a separate motion for each agency that pays a stipend.

NOTIFICATION

Publication of the Agenda

ATTACHMENTS

1. 2013 Council Committee Participation – Mayor’s Recommendations for Vacant Positions
2. 2013 Meeting Schedule

Prepared By:
Cindy Miller
Executive Assistant to the Mayor/City Council

Department Head Approval:
Jane Halstead
City Clerk

Council Action	
Approved as requested:	Referred to:
Approved as amended:	For:
Denied:	Continued until:
Other:	Hearing set for:

**CITY COUNCIL
2013 COUNCIL COMMITTEE PARTICIPATION
Mayor's Recommendations to Fill Vacant Positions**

CITY COUNCIL ADVISORY COMMISSIONS/ BOARDS:

	<i>Primary</i>	<i>Alternate</i>
Arts Commission	BACA	STEWART
Environmental and Historical Preservation Board	BACA	STEWART
Library Commission	BACA	STEWART
Parks & Recreation Commission	BACA	STEWART
Recreational Trails Board	MOLINA	BACA
Senior Citizens' Board	MOLINA	STEWART
Traffic Safety Commission	STEWART	MOLINA

CITY COUNCIL SUBCOMMITTEES:

Economic Development Subcommittee	OWINGS/ MOLINA	BACA
Finance Subcommittee	OWINGS/ MOLINA	STEWART
Public Safety Subcommittee	OWINGS/MOLINA	BACA

INTER-AGENCY:

March Joint Powers Commission (JPC)	OWINGS/ BACA	MOLINA
School Districts/City Joint Task Force	MOLINA/STEWART	BACA
*Riverside County Habitat Conservation Agency (RCHCA)	MOLINA	STEWART
*Riverside County Transportation Commission (RCTC)	OWINGS	MOLINA
*Riverside Transit Agency (RTA)	MOLINA	BACA
*Western Riverside Council of Governments (WRCOG)	OWINGS	MOLINA
*Western Riverside County Regional Conservation Authority (RCA)	MOLINA	STEWART

* Mayor participation or designee

Approved:

This page intentionally left blank.

2013 MEETING SCHEDULE

Appointing Authority	Committee	Meeting Time	Meeting Schedule	Meeting Location	Meeting Address	Stipend
CITY ADVISORY BOARDS/COMMISSIONS						
Mayor	Arts Commission	6:30 p.m.	4th Wednesday of each month	Conference and Rec Center	14075 Frederick Street Moreno Valley	N/A
Mayor	Environmental and Historical Preservation Board	7:00 p.m.	2nd Monday of each odd numbered month	Council Chamber	14177 Frederick Street Moreno Valley	N/A
Mayor	Recreational Trails Board	5:00 p.m.	4th Wednesday of each odd numbered month	Senior Center	14075 Frederick Street Moreno Valley	N/A
Mayor	Library Commission	7:00 p.m.	3rd Thursday of each month	Library	25048 Alessandro Blvd. Moreno Valley	N/A
Mayor	Parks and Recreation Commission	6:00 p.m.	2nd Thursday of each odd numbered month	Conference and Rec Center	14075 Frederick Street Moreno Valley	N/A
Mayor	Senior Citizens' Board	3:00 p.m.	3rd Monday of each month	Senior Community Center	25075 Fir Avenue Moreno Valley	N/A
Mayor	Traffic Safety Commission	6:00 p.m.	1st Wednesday of each month	Council Chamber	14177 Frederick Street Moreno Valley	N/A
COUNCIL SUBCOMMITTEES						
Mayor	Economic Development Subcommittee		Generally 2nd Thurs. of each month	Council Chamber	14177 Frederick Street	N/A
Mayor	Finance Subcommittee		No established time/day	Training Room	14177 Frederick Street	N/A
Mayor	Public Safety Subcommittee	10:00 a.m.	Generally on a Monday of each month	Training Room	14177 Frederick Street	N/A
INTER-AGENCIES						
Mayor	League of California Cities (LCC)	6:00 p.m.	2nd Monday of odd numbered month	Varies	Varies	N/A
Mayor	Riverside County Division					
Mayor	Riverside County Habitat Conservation Agency (RCHCA)	10:00 a.m.	Quarterly, 3rd Thursday Feb., May, Sept., Nov.	County Admin Center	Board Chamber, Riverside	\$100 per meeting
Mayor	Western Riverside County Regional Conservation Authority (RCA)	12:30 p.m.	1st Monday of each month	County Admin Center	4080 Lemon St., 1st Floor Board Chamber, Riverside	\$100 per meeting Mileage @ IRS rate
Mayor	School Districts/City Joint Task Force	12:00 p.m. - 1:00 p.m.	About every six weeks,	Conference and Rec Center	14075 Frederick Street Moreno Valley	N/A
Mayor	March Joint Powers Commission (MJPC)	8:30 a.m.	3rd Wed. of each month	JPA Conference Center	23533 Meyer Drive, Riverside	\$100 per meeting
MJPA	Operations Assurance Task Force	8:30 a.m.	1st Wed. of each month Study Session	JPA Conference Center	23533 Meyer Drive, Riverside	\$100 per meeting
Mayor	Riverside Transit Agency (RTA)	2:00 p.m.	Will meet as needed 4th Thursday of each month	RTA Office	1825 3rd Street, Riverside	\$100 per meeting \$150 per day \$600 cap per month
RTA	RTA Operations Committee	1:00 p.m.	1st Wednesday of each month	RTA Office	1825 3rd Street, Riverside	\$150 per day \$600 cap per month
TA	RTA Transportation NOW (T-NOW)	11:30 a.m.	3rd Thursday of each month	Council Chamber	14177 Frederick Street Moreno Valley	\$150 per day \$600 cap per month

Item No. G.4

2013 MEETING SCHEDULE

pointing Authority	Committee	Meeting Time	Meeting Schedule	Meeting Location	Meeting Address	Stipend
ER-AGENCIES (cont.)						
or	Riverside County Transportation Commission (RCTC)	9:30 a.m.	2nd Wednesday of each month	County Admin Center	4080 Lemon St., 1st Floor Board Chambers, Riverside	\$100 per day, 4 days a month max
CTC	Mobile Source Air Pollution Reduction Review Committee (MSRC)	2:00 p.m.	3rd Thursday of each month	SCAQMD Headquarters	21885 E. Copley Dr., Conf. Room CC8, Diamond Bar	\$100 per day, 4 days a month max
RCTC	RCTC Metrolink Briefings	9:30 a.m.	Wed. prior to SCRRRA meeting, 4th Fri. of month	County Admin Center	4080 Lemon St, 3rd Floor, Riverside (Or Teleconference)	\$100 per day, 4 days a month max
RCTC	RCTC Programs and Projects	1:30 p.m.	4th Monday of each month	County Admin Center	4080 Lemon St., 1st Floor, Board Chambers, Riverside	\$100 per day, 4 days a month max
RCTC	Southern California Regional Rail Authority (SCRRRA) Board	10:00 a.m.	4th Friday of each month	SCAG Offices	818 W. 7th St., 12th Floor Los Angeles	\$100 per day, 4 days a month max
RCTC	Southern California Regional Rail Authority (SCRRRA) Committee	10:00 a.m.	2nd Friday of each month	SCRRRA Offices	700 S. Flower, Suite 2600 Los Angeles	\$100 per day, 4 days a month max
Mayor	Western Riverside Council of Governments Executive Committee (WRCOG)	2:00 p.m.	1st Monday of each month	County Admin Center	4080 Lemon Street, 1st Floor Board Chambers, Riverside	\$150 per meeting
WRCOG	Administrative & Finance Subcommittee	12:00 p.m.	2nd Wednesday of each month	County Admin Center	4080 Lemon St., 4th Floor, Conf. Room A, Riverside	\$150 per meeting
WRCOG	Southern California Association of Governments (SCAG) Membership and Communication Subcommittee	8:30 a.m. - 10:30 a.m.	3rd Tuesday of each month prior to Regional Council	SCAG Offices	818 West 7th Street, Riverside B Room, Los Angeles	\$120 per day, cap of 8 meetings per month
WRCOG	Southern California Association of Governments (SCAG) Community, Economic, and Human Dev. (CEHD)	10:00 a.m. - 12:00 p.m.	1st Thursday of each month	SCAG Offices	818 West 7th Street, Los Angeles	\$120 per day, cap of 8 meetings per month
WRCOG	Southern California Association of Governments (SCAG) Regional Council	12:15p.m. - 2:00 p.m.	1st Thursday of each month	SCAG Offices	818 West 7th Street, San Bernardino Room, Los Angeles	\$120 per day, cap of 8 meetings per month
WRCOG	Southern California Association of Governments (SCAG) Transportation Committee (TC)	10:00 a.m. - 12:00 p.m.	1st Thursday of each month	SCAG Offices	818 West 7th Street, San Bernardino Room, Los Angeles	\$120 per day, cap of 8 meetings per month
County of Riverside	Airport Land Use Commission (ALUC)	9:00 a.m. - 11:00 a.m.	2nd Thursday of each month	County Admin Center	County Administration Center 4080 Lemon Street Board Room - 1st Floor	\$150 per day
SUBCOMMITTEES						
	Moreno Valley Chamber of Commerce Legislative Action Committee	7:30 a.m.	2nd Friday of each month	Brandon's Diner	24626 Sunnymead Blvd. Moreno Valley	N/A
	Riverside Housing Development Corporation (RHDC) Board	No Regular Meeting	Meet approximately three times a year		4250 Brockton Avenue Riverside	TBA

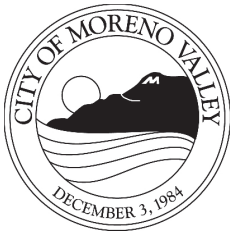

APPROVALS	
BUDGET OFFICER	<i>me</i>
CITY ATTORNEY	<i>SMB</i>
CITY MANAGER	<i>d</i>

Report to City Council

TO: Mayor and City Council

FROM: Jane Halstead, City Clerk, CMC

AGENDA DATE: August 27, 2013

TITLE: DISCUSSION AND APPOINTMENT REGARDING MAYOR PRO TEM POSITION

RECOMMENDED ACTION

Recommendations: That the City Council:

1. Select a Council Member to serve as Mayor Pro Tem for the remainder of the unexpired term.

SUMMARY

The City Council's Rules of Procedure provide that the City Council meet annually at its first regular meeting in December of each year to choose one of its number as Mayor Pro Tem. Due to the resignation of the Council Member serving as Mayor Pro Tem on August 13, 2013, the City Council may appoint a Mayor Pro Tem to fill the vacancy.

Section 4.2.3 of the Rules of Procedure provides that nominations for the office of Mayor Pro Tem may be made by any member of the City Council and need not be seconded in order to be effective. Each selection shall be by three or more affirmative votes. In the event that no person receives three or more votes in the selection process for the office, the selection process shall be repeated immediately; provided, however, that the two persons receiving the highest number of votes in the preceding selection process shall be the only nominees for the office to be filled. If, upon repeating the selection process for Mayor Pro Tem, no person has yet received three affirmative votes for such office, the City Council may either repeat the selection process until the officer has been duly selected or may continue the selection to the next regular meeting of the City Council.

Voting in the selection of Mayor Pro Tem shall be by written ballot unless the City Council, by three or more affirmative votes, determines to conduct the selection process by voice vote. If conducted by written ballot, the vote of each Council Member shall remain undisclosed until all votes have been cast and have been lodged with the City Clerk. The City Clerk shall then read aloud into the minutes of the City Council the identity of the voting Council Member and the name of the person for whom such person is voting. The written ballots shall be public documents and shall be retained in the records of the City Council. The Standard Code of Parliamentary Procedure shall apply to resolve any question of procedure arising during the selection process, which is not governed by Section 4.2 of the City Council Rules of Procedure.

The new appointed Mayor Pro Tem shall serve until the next meeting scheduled for selection of Mayor Pro Tem, pursuant to Section 4.2 of City Council's Rules of Procedure.

ALTERNATIVES

1. Conduct the appointment by selecting a new Mayor Pro Tem.
2. Continue the selection to the next regular meeting of the City Council if upon repeating the selection process, no person receives three affirmative votes for Mayor Pro Tem.

FISCAL IMPACT

There is no fiscal impact associated with the recommended action.

ATTACHMENTS

None

Prepared By:
Jane Halstead
City Clerk, CMC

Department Head Approval:
Jane Halstead
City Clerk, CMC

Council Action	
Approved as requested:	Referred to:
Approved as amended:	For:
Denied:	Continued until:
Other:	Hearing set for:

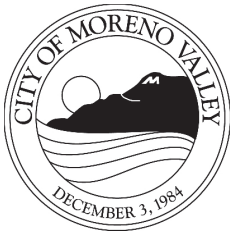

APPROVALS	
BUDGET OFFICER	<i>me</i>
CITY ATTORNEY	<i>SMB</i>
CITY MANAGER	<i>d</i>

Report to City Council

TO: Mayor and City Council

FROM: Jane Halstead, City Clerk, CMC

AGENDA DATE: August 27, 2013 (Continued from June 25, 2013)

TITLE: APPOINTMENTS TO THE CITY COUNCIL ADVISORY BOARDS AND COMMISSIONS

RECOMMENDED ACTION

Recommendations: That the City Council:

1. Extend the expiring August 31, 2013 terms of the current City Council Advisory Board and Commission members to October 31, 2013 to allow additional time for recruitment.

SUMMARY

At the June 25, 2013, the City Council continued appointments to various advisory boards and commissions to the August 27, 2013 City Council meeting and extended June 30, 2013 expiring terms to August 31, 2013. Applications were accepted by the City Clerk's Office to fill vacancies for the various City Council Boards and Commissions, with certain terms expiring June 30, 2013. An insufficient number of applications were received to fill the vacancies.

Members with expiring terms were notified and advised of the need to submit a new application to be considered for reappointment. Appropriate time frames with respect to posting notices of vacancies were followed.

As provided in the City's Municipal Code, the appointees will serve without compensation for designated terms.

Staff recommends extending the August 31, 2013 expiring terms of the current board and commission members to October 31, 2013 to allow additional time for recruitment

to fill vacancies. Staff recommends extending the deadline to submit applications to Monday, September 30, 2013.

The commissions, boards, applicants, and vacancies are as follows:

ACCESSIBILITY APPEALS BOARD

Two (2) terms expiring June 30, 2016
Physically Challenge Representative

One (1) term expiring June 30, 2015
Public Representative

One (1) term expiring June 30, 2014
Construction Representative

Applicants:

L. Lawrence Baird *
Mary Mc Bean

ARTS COMMISSION

One (1) term expiring June 30, 2016
One (1) term expiring June 30, 2015

Applicants:

Stephen "Steve" Heaton
Clarence Robert Hogan
Eric von Mizener *
Saifur R. Osmani ***

ENVIRONMENTAL AND HISTORICAL PRESERVATION BOARD

Three (3) terms expiring June 30, 2016

Applicants:

Jan L. Beyers *
Reese McClure *
Naeem Qureshi *

LIBRARY COMMISSION

Two (2) terms expiring June 30, 2016
Two (2) terms expiring June 30, 2015

Applicants:

Christine A. Duchene
David Namazi **

PARKS AND RECREATION COMMISSION

Three (3) terms expiring June 30, 2016

Applicants:

James C. Baker II *
Juanita Maria Barnes *
Virgil Chancy*
Saifur R. Osmani **/***

RECREATIONAL TRAILS BOARD

Three (3) terms expiring June 30, 2016

Applicants:

Carolyn D. Bailey
Manzell Baskerville *
Kim M. Nelson *

SENIOR CITIZENS' BOARD

Three (3) terms expiring June 30, 2016

One (1) term expiring June 30, 2015

Two (2) terms expiring June 30, 2014

Applicants:

Sara W. Anderson *
Maria D. Davis **
Vonzetta Fielding *
Linda D. Moore **
Delanna Townsend *

TRAFFIC SAFETY COMMISSION

Two (2) terms expiring June 30, 2016

One (1) term expiring June 30, 2014

Applicants:

Miguel Arciniega *
Shor Denny
Denise Fleming
Thomas D. Hines
Alvin C. Horn
Thomas Ketcham
Lori Nickel

*Incumbent

** Was not able to attend at least one meeting prior appointment

*** Applied for more than one board/commission

ALTERNATIVES

1. Extend the expiring August 31, 2013 terms of the current board and commission members to October 31, 2013 to allow time for additional recruitment.
2. Do not extend the expiring June 30, 2013 terms of the current board and commission members (staff doesn't recommend this option).

NOTIFICATION

1. Publication of the agenda
2. Report and agenda mailed to applicants

ATTACHMENTS

None

Prepared By:
Ewa Lopez
Deputy City Clerk, CMC

Department Head Approval:
Jane Halstead
City Clerk, CMC

Council Action	
Approved as requested:	Referred to:
Approved as amended:	For:
Denied:	Continued until:
Other:	Hearing set for: